

POWER MANAGEMENT

Description

The SC1110 is a low-cost, full featured, synchronous voltage-mode controller designed to generate termination voltage in double data rate (DDR) memory systems and other applications where wide data bus need to be actively terminated. Synchronous control of the MOSFET half bridge allows power flowing bi-directionally. The termination voltage can be tightly regulated to track the chipset voltage, i.e. to be exactly 50% of that at all times.

The SC1110 is ideal for low cost implementation of termination voltage supplies. SC1110 features include temperature compensated voltage reference, triangle wave oscillator and current sense comparator circuitry, and allows the use of inexpensive N-channel power MOSFETs.

The SC1110 operates at a fixed 250kHz, providing an optimum compromise between efficiency, transient performance, external component size, and cost.

Features

- ◆ Generates termination voltages for active termination schemes
- ◆ 1% set point accuracy
- ◆ For $\pm 7A$ output current, transient regulation is better than $\pm 80mV$
- ◆ V_{REFIN} pin available for external 50% resistive divider to allow termination voltage track of the chip set voltage
- ◆ Buffered V_{REFOUT} for system usage
- ◆ $R_{DS(ON)}$ sensing for over current protection in hiccup mode
- ◆ Soft start and logic input enabling
- ◆ 250kHz switching for best transient and efficiency performance
- ◆ Gate drive capable for 0.5A sourcing and sinking

Applications

- ◆ For DDR memory systems
- ◆ For active termination schemes in high speed logic systems

Typical Application Circuit

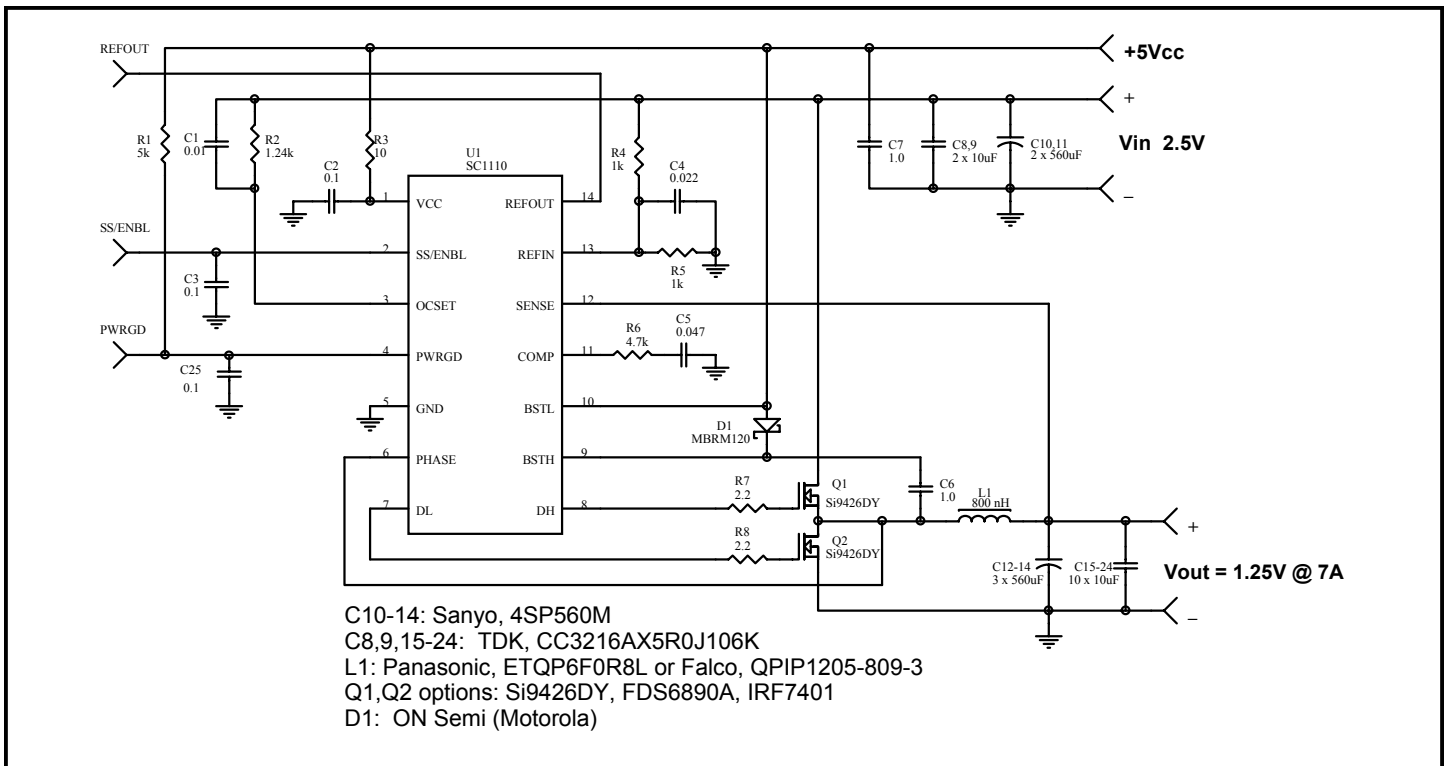

POWER MANAGEMENT
Absolute Maximum Ratings

Exceeding the specifications below may result in permanent damage to the device, or device malfunction. Operation outside of the parameters specified in the Electrical Characteristics section is not implied.

Parameter	Symbol	Maximum	Units
V _{CC} , BSTL to GND	V _{IN}	-0.5 to 14	V
PGND to GND		+0.5	V
PHASE to GND		-0.3 to 18	V
BSTH to PHASE		14	V
Thermal Impedance Junction to Case	θ _{JC}	45	°C/W
Thermal Resistance Junction to Ambient	θ _{JA}	115	°C/W
Operating Temperature Range	T _A	0 to 70	°C
Storage Temperature Range	T _{STG}	-65 to +150	°C
Lead Temperature (Soldering) 10 Sec.	T _{LEAD}	300	°C
ESD Rating (Human Body Model)	V _{ESD}	2	kV

Electrical Characteristics

Unless specified: V_{CC} = 4.75V to 12.6V; GND = PGND = 0V; FB = V_O; V_{BSTL} = 12V; V_{BSTH-PHASE} = 12V; T_J = 25°C

Parameter	Conditions	Min	Typ	Max	Units
Power Supply					
Supply Voltage	V _{CC}	4.4		12.6	V
Supply Current			8	12	mA
Line Regulation	V _O = 2.5V ± 0.5V, V _O = V _{IN} /2 @ 0A		0.5		%
Under Voltage Lockout					
Turn-On Threshold			4.15		V
Turn-Off Threshold			3.95		V
Error Amplifier					
Transconductance			2		mS
Open Loop DC Gain			50		dB
Bandwidth - 3dB	(Unity gain crossover 70MHz)		500		kHz
COMP Source Capability			±250		µA
Input Bias			2	5	µA
Oscillator					
Oscillator Frequency		225	250	275	kHz
Oscillator Max Duty Cycle		90	95		%
Ramp Height			1		V

POWER MANAGEMENT
Electrical Characteristics (Cont.)

 Unless specified: $V_{CC} = 4.75V$ to $12.6V$; $GND = PGND = 0V$; $FB = V_O$; $V_{BSTL} = 12V$; $V_{BSTH-PHASE} = 12V$; $T_J = 25^\circ C$

Parameter	Conditions	Min	Typ	Max	Units
Timing					
Minimum Off-Time			200		ns
Dead Time	Guaranteed by characterization	80			ns
MOSFET Drivers					
Peak DH Sink/Source Current	BSTH - DH = 4.5V, DH - PHASE = 3.0V DH - PHASE = 1.5V	0.5			A
		0.1			
Peak DL Sink/Source Current	BSTL - DL = 4.5V, DL - GND = 3.0V DL - GND = 1.5V	0.5			A
		0.1			
Protection					
Overcurrent Set Isource	$V_{OCSET} = 2.2V$	180	200	220	μA
Soft Start					
Charge Current	$V_{SS} = 1.5V$	8	10	12	μA
Discharge Current	$V_{SS} = 1.5V$	1	2	3	μA
Power Good					
Upper Threshold			112		%
Lower Threshold			88		%
PWRGD Voltage Low	$I_{PWRGD} = 2mA$			0.5	V
Reference					
REFOUT Source Current			3		mA
Offset	$REF_{IN} = 1.25V$	-5		5	mV
Enable					
Threshold		0.55	0.60	0.65	V

POWER MANAGEMENT

Timing Diagrams

SIMULATION WAVEFORMS

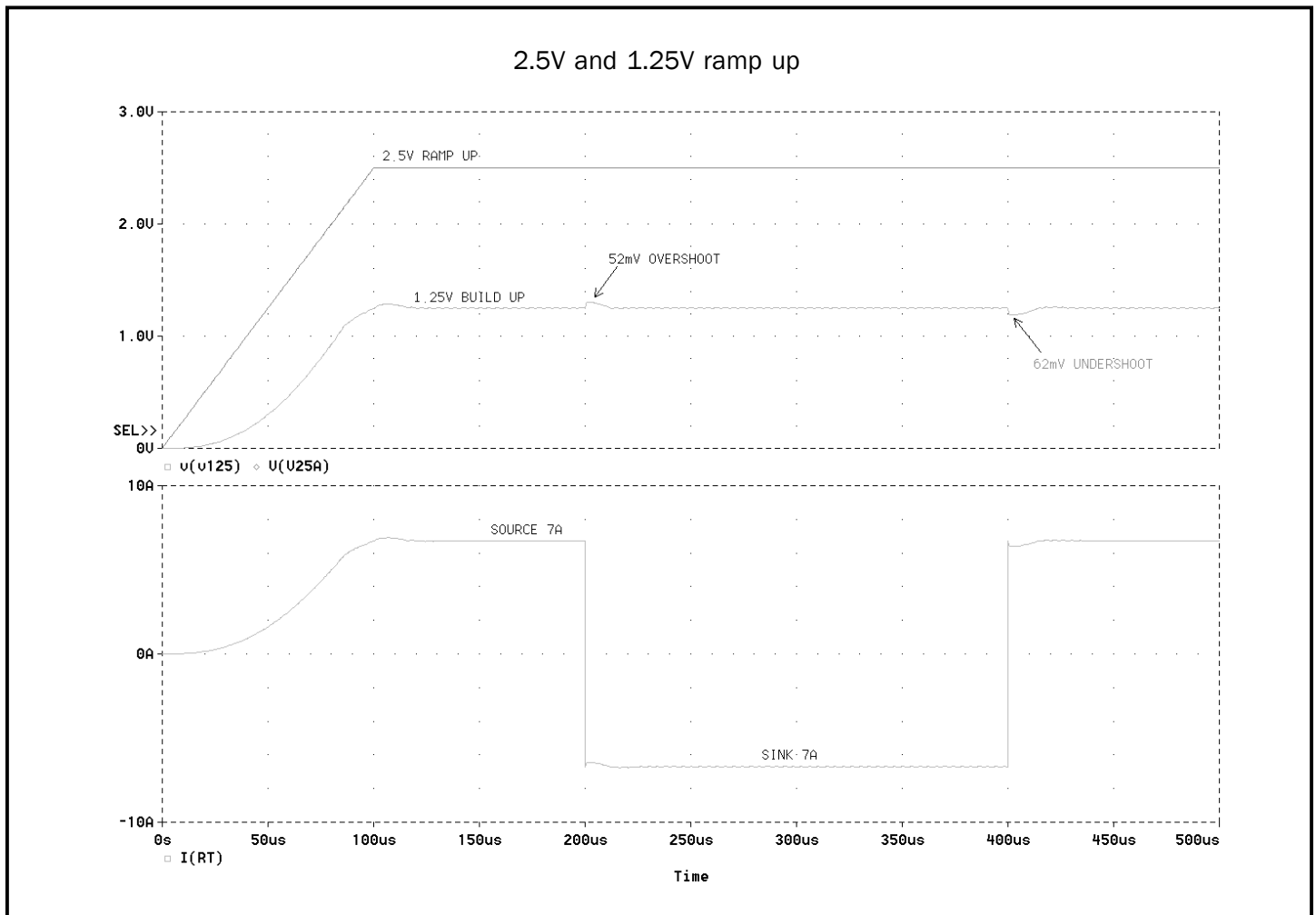

Output current of the VTT supply

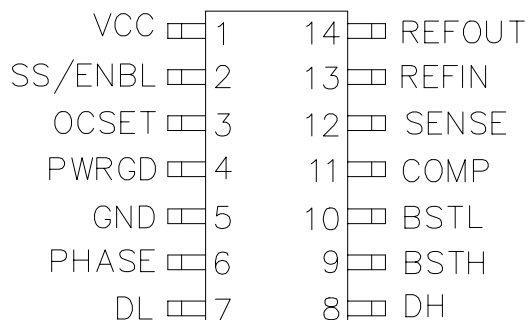
POWER MANAGEMENT
Pin Configuration

(14 Pin SOIC or TSSOP)

Ordering Information

Device ⁽¹⁾	Package ⁽¹⁾⁽²⁾	Temp Range (T _J)
SC1110CSTRT	SO-14	0° to 125°C
SC1110TSTRT	TSSOP-14	

Notes:

(1) Only available in tape and reel packaging. A reel contains 2500 devices.

(2) Lead free product.

Pin Descriptions

Pin #	Pin Name	Pin Function
1	VCC	Chip Supply Voltage.
2	SS/ENBL	Soft start/Enable.
3	OCSET	Current limit set point.
4	PWRGD	Logic high indicates correct output.
5	GND	Ground.
6	PHASE	Phase node connection between MOSFETs.
7	DL	Low side driver output.
8	DH	High side driver output.
9	BSTH	High side driver supply.
10	BSTL	Low side driver supply.
11	COMP	Error amplifier output, compensation.
12	SENSE	Error amplifier negative input.
13	REFIN	Error amplifier positive input.
14	REFOUT	Buffered reference voltage.

NOTE:

(1) All logic level inputs and outputs are open collector TTL compatible.

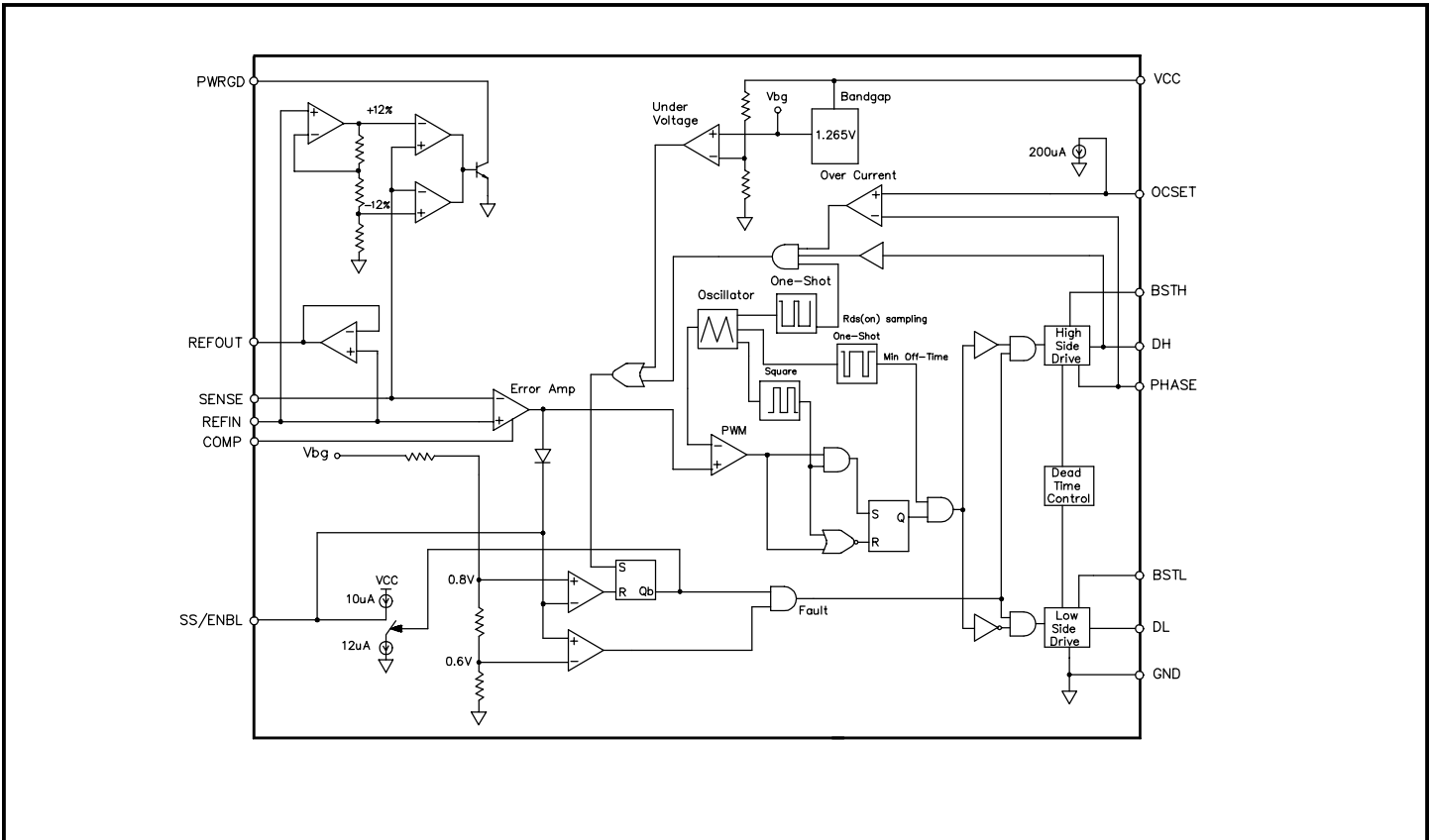
POWER MANAGEMENT
Block Diagram

Applications Information
THEORY OF OPERATION
Synchronous Buck Converter

$V_{\text{TERMINATION}}$ power is provided by a synchronous, voltage-mode pulse width modulated (PWM) controller. This section has all the features required to build a high efficiency synchronous buck converter for termination of power application.

The output voltage of the synchronous converter is set and controlled by the output of the error amplifier. The external resistive divider generates reference voltage for the error amplifier from the chipset voltage which is usually 2.5V. The inverting input of the error amplifier receives its voltage from the SENSE pin.

The internal oscillator uses an on-chip capacitor and trimmed precision current sources to set the oscillation frequency to 250kHz. The triangular output of the oscillator sets the reference voltage at the inverting input of the PWM comparator. The non-inverting input of the comparator receives it's input voltage from the error ampli-

fier. When the oscillator output voltage drops below the error amplifier output voltage, the comparator output goes high. This pulls DL low, turning off the low-side FET, and DH is pulled high, turning on the high-side FET (once the cross-current control allows it). When the oscillator voltage rises back above the error amplifier output voltage, the comparator output goes low. This pulls DH low, turning off the high-side FET, and DL is pulled high, turning on the low-side FET (once the cross-current control allows it).

As SENSE increases, the output voltage of the error amplifier decreases. This causes a reduction in the on-time of the high-side MOSFET connected to DH, hence lowering the output voltage.

Under Voltage Lockout

The under voltage lockout circuit of the SC1110 assures that both the high-side MOSFET driver outputs remain in the off state whenever the supply voltage drops below set parameters. Lockout occurs if V_{CC} falls below 4.1V. Normal operation resumes once V_{CC} rises above 4.2V.

POWER MANAGEMENT**Applications Information****Soft Start**

Initially, SS/ENABLE sources 10 μ A of current to charge an external capacitor. The outputs of the error amplifiers are clamped to a voltage proportional to the voltage on SS/ENABLE. This limits the on-time of the high-side MOSFETs, thus leading to a controlled ramp-up of the output voltages.

 $R_{DS(ON)}$ Current Limiting

The current limit threshold is set by connecting an external resistor from the V_{CC} supply to OCSET. The voltage drop across this resistor is due to the 200 μ A internal sink sets the voltage at the pin. This voltage is compared to the voltage at the PHASE node. This comparison is made only when the high-side drive is high to avoid false current limit triggering due to uncontributing measurements from the MOSFET's off-voltage. When the voltage at PHASE is less than the voltage at OCSET, an overcurrent condition occurs and the soft start cycle is initiated. The

synchronous switcher turns off and SS/ENABLE starts to sink 2 μ A. When SS/ENABLE reaches 0.8V, it then starts to source 10 μ A and a new cycle begins.

Hiccup Mode

During power up, the SS/ENABLE pin is internally pulled low until VCC reaches the undervoltage lockout level of 4.2V. Once V_{CC} has reached 4.2V, the SS/ENABLE pin is released and begins to source 10 μ A of current to the external soft-start capacitor. As the soft-start voltage rises, the output of the internal error amplifier is clamped to this voltage. When the error signal reaches the level of the internal triangular oscillator, which swings from 1V to 2V at a fixed frequency of 250 kHz, switching occurs. As the error signal crosses over the oscillator signal, the duty cycle of the PWM signal continues to increase until the output comes into regulation. If an over-current condition has not occurred the soft-start voltage will continue to rise and level off at about 2.2V.

POWER MANAGEMENT

Typical Characteristics

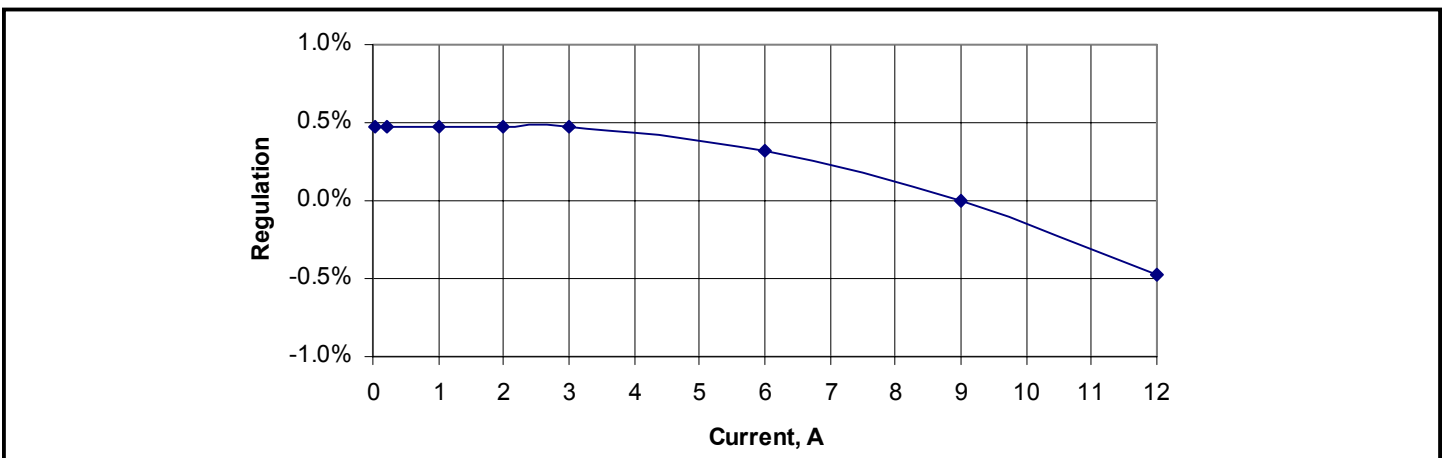
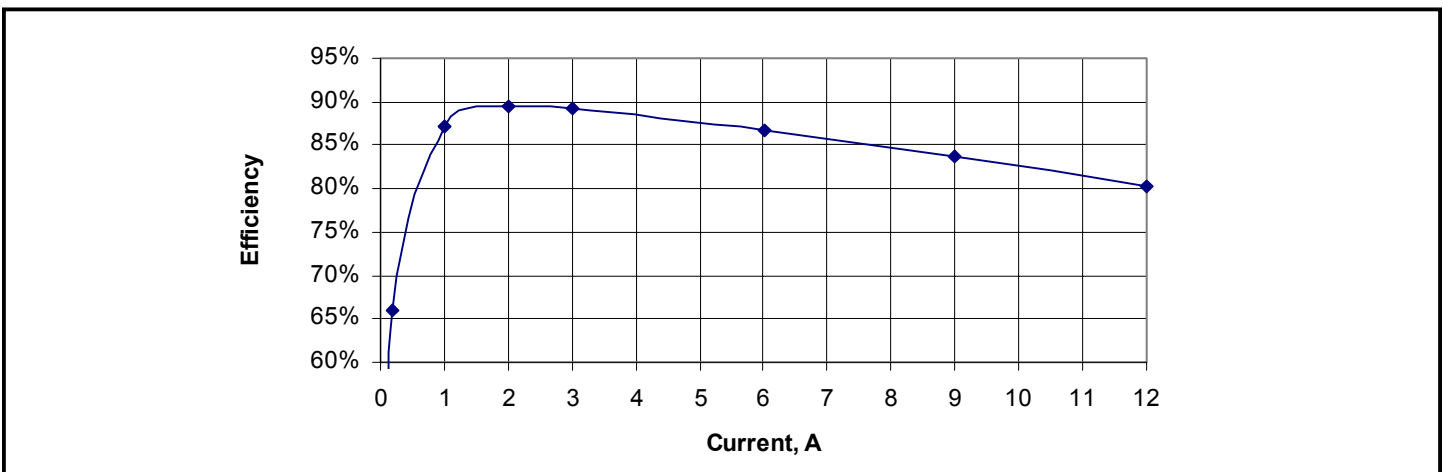
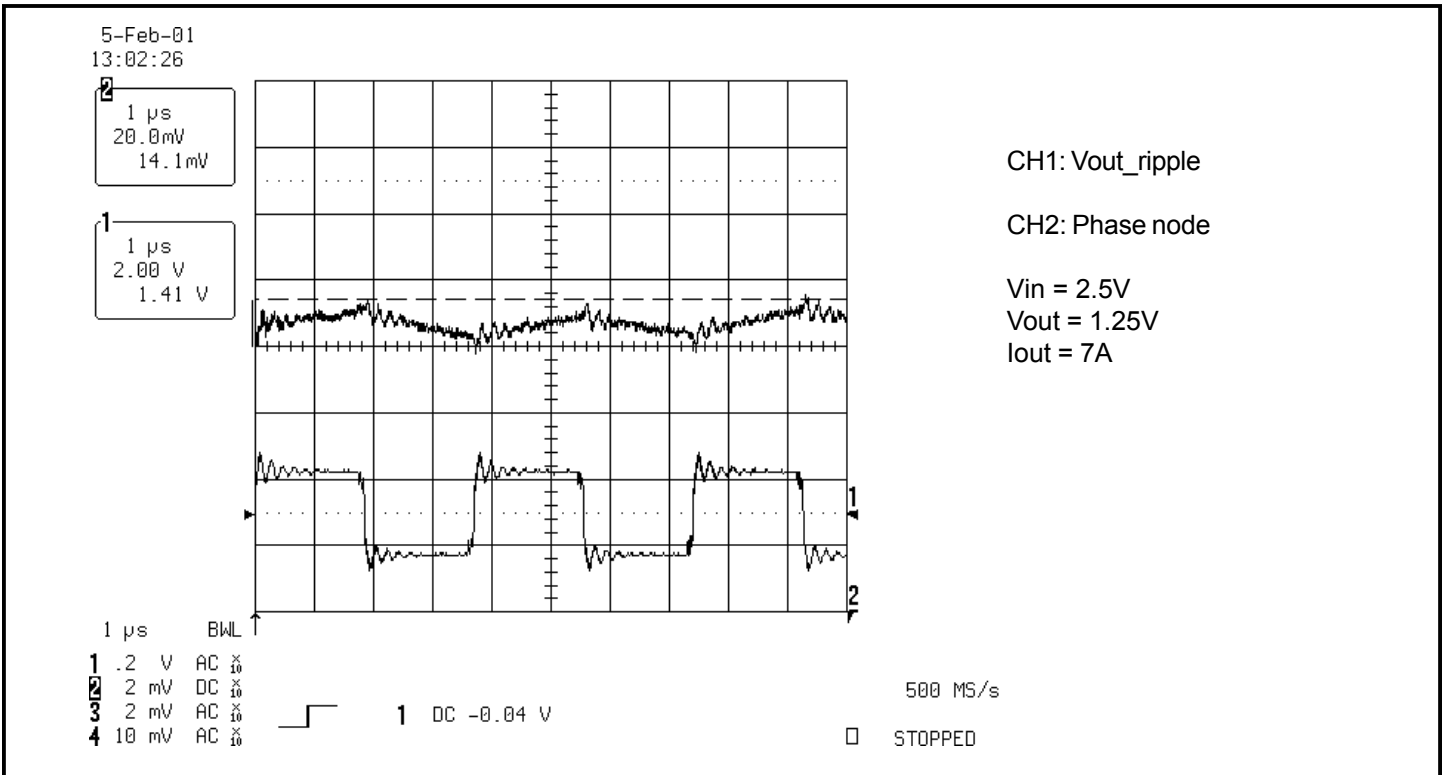

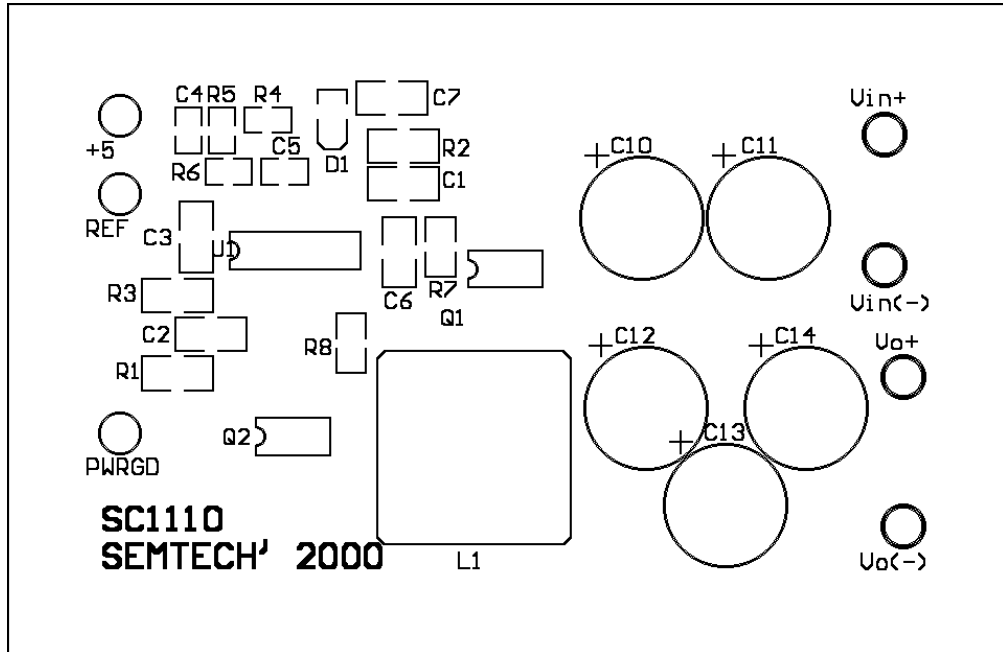
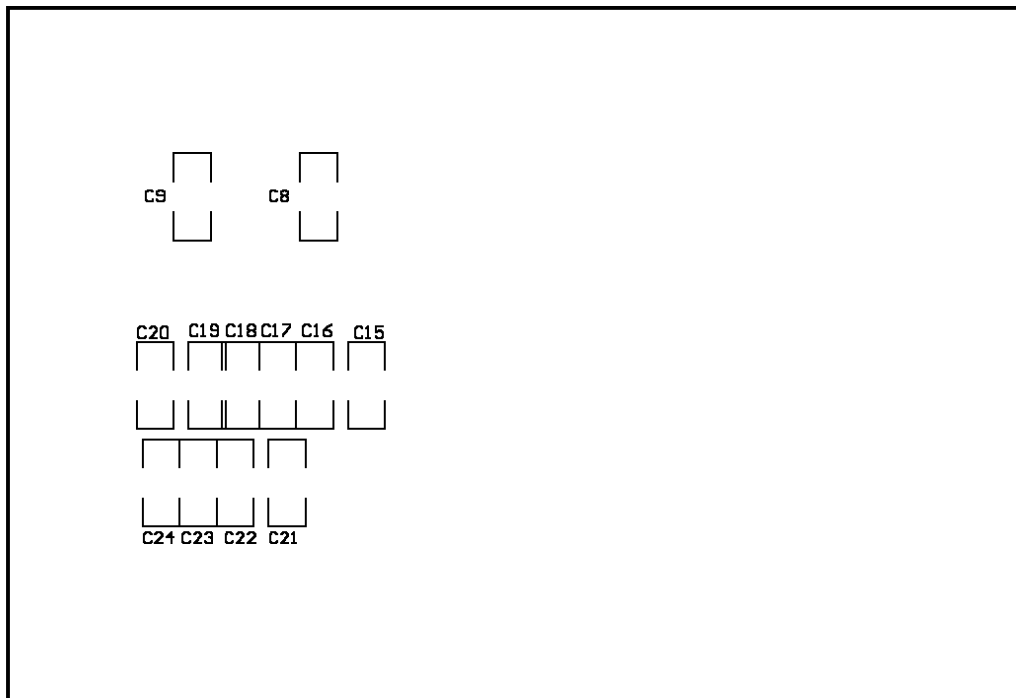
Top View

Bottom View

POWER MANAGEMENT

Evaluation Board (Cont.)

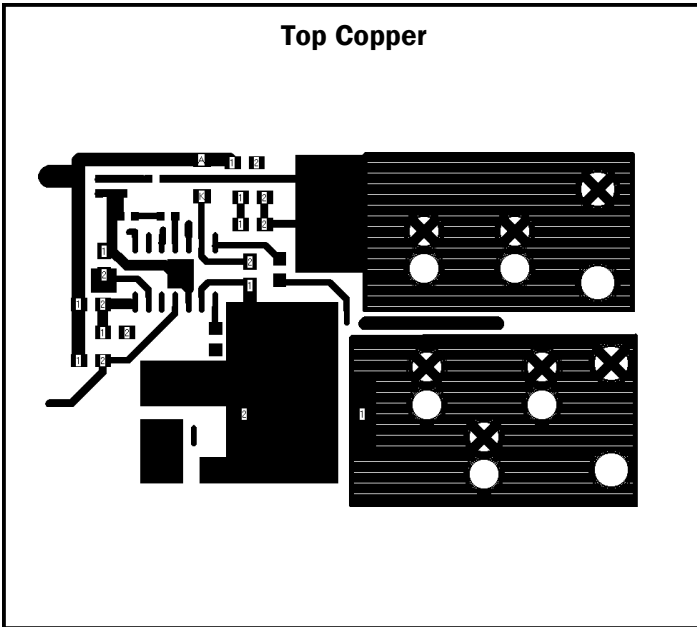
Top Copper



Bottom Copper

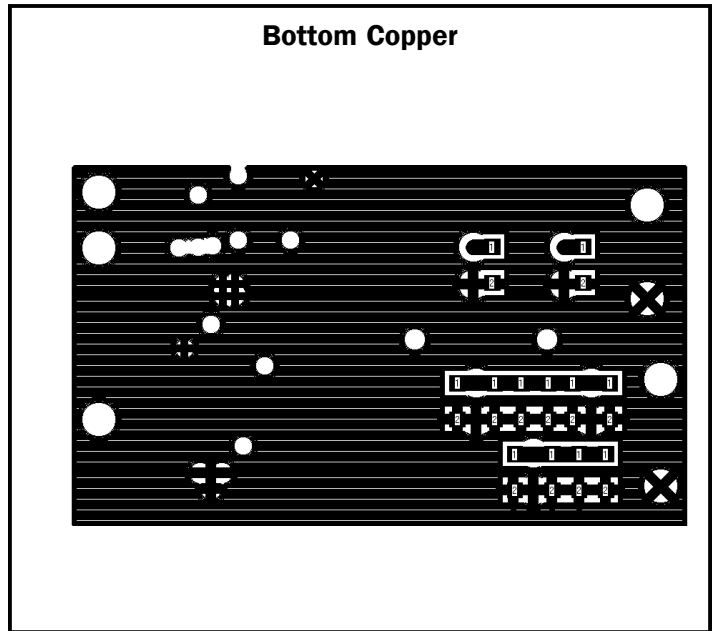

Midlayer 1

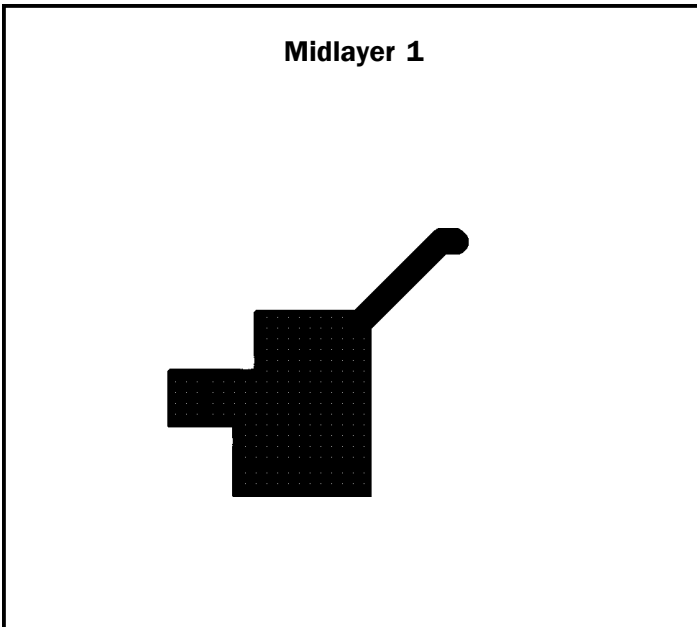

Midlayer 2

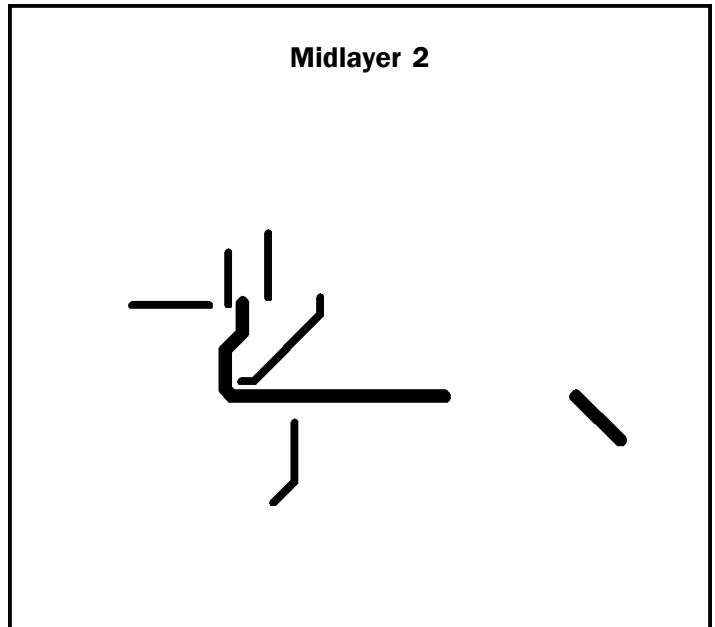

POWER MANAGEMENT

Outline Drawing - SO-14

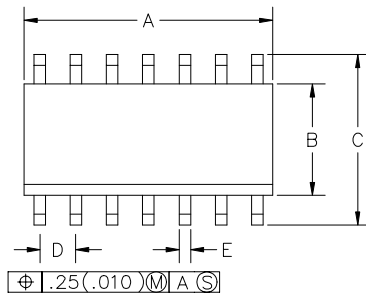

DIM ^N	INCHES		MM		NOTE
	MIN	MAX	MIN	MAX	
A	.337	.344	8.55	8.75	2
B	.150	.158	3.80	4.00	3
C	.228	.244	5.80	6.20	
D	.050	BSC	1.27	BSC	
E	.013	.020	0.33	0.51	
F	.004	.010	0.10	0.25	
H	.053	.069	1.35	1.75	
J	.010	.020	0.25	0.50	
K	.007	.010	.19	.25	
M	.016	.050	0.40	1.27	

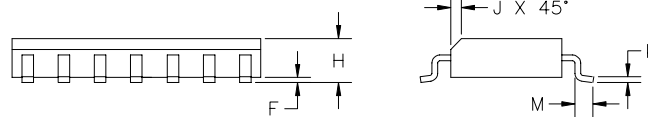

- ③ DIMENSION "B" DOES NOT INCLUDE INTER-LEAD FLASH OR PROTRUSIONS. INTER-LEAD FLASH AND PROTRUSIONS SHALL NOT EXCEED .25 mm (.010") PER SIDE.
- ④ DIMENSION "A" DOES NOT INCLUDE MOLD FLASH, PROTRUSIONS OR GATE BURRS. MOLD FLASH, PROTRUSIONS AND GATE BURRS SHALL NOT EXCEED .15 mm (.010") PER SIDE.
- ① CONTROLLING DIMENSION : MILLIMETER

Land Pattern - SO-14

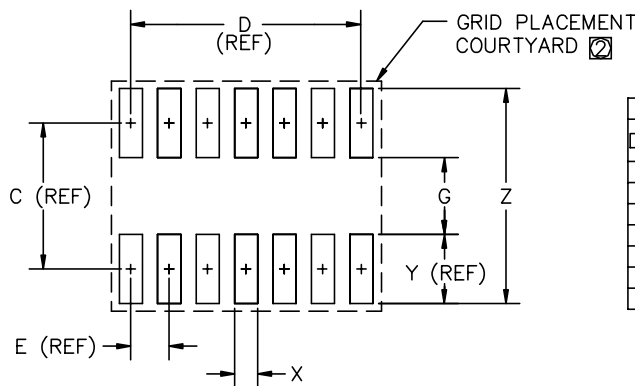

DIM ^N	INCHES		MM		NOTE
	MIN	MAX	MIN	MAX	
C	-	.19	-	5.00	-
D	-	.30	-	7.62	-
E	-	.05	-	1.27	-
G	.10	.11	2.60	2.80	-
X	.02	.03	.60	.80	-
Y	-	.09	-	2.40	-
Z	-	.29	7.20	7.40	-

- ② GRID PLACEMENT COURTYARD IS 20x16 ELEMENTS (10mm X 8mm) IN ACCORDANCE WITH THE INTERNATIONAL GRID DETAILED IN IEC PUBLICATION 97.
- ① CONTROLLING DIMENSION: MILLIMETERS

POWER MANAGEMENT

Outline Drawing - TSSOP-14

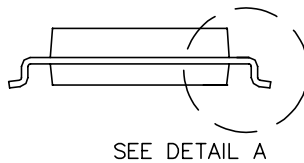
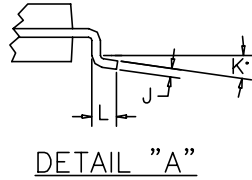
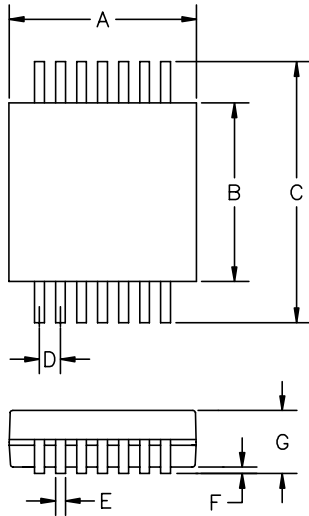

DIM ^N	INCHES		MM		NOTE
	MIN	MAX	MIN	MAX	
A	.193	.201	4.90	5.10	②
B	.169	.177	4.30	4.50	②
C	.252 BSC		6.40 BSC		—
D	.026 BSC		.65 BSC		—
E	.007	.012	.19	.30	—
F	.002	.006	.05	.15	—
G	.047		1.20		—
J	.004	.008	.09	.20	—
K	0°	8°	0°	8°	—
L	.018	.030	.45	.75	—

JEDEC MO-153AB1

② DIMENSIONS A AND B DO NOT INCLUDE MOLD PROTRUSIONS.

① CONTROLLING DIMENSIONS: MILLIMETERS.

Land Pattern - TSSOP-14

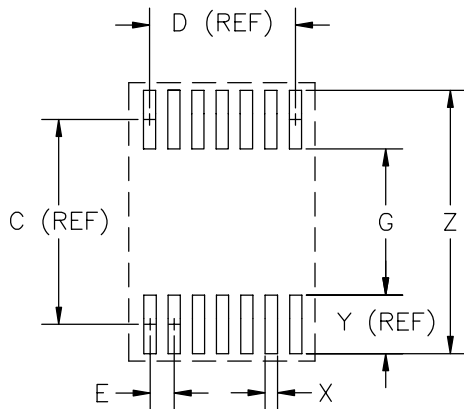

DIM ^N	INCHES		MM		NOTE
	MIN	MAX	MIN	MAX	
C	—	.218	—	5.53	REF
D	—	.156	—	3.96	REF
E	—	.026	—	0.65	BSC
G	.155	—	3.947	—	—
X	—	.013	—	0.323	REF
Y	—	.062	—	1.583	—
Z	—	.280	—	7.113	—

② GRID PLACEMENT COURTYARD IS 10 X 15 ELEMENTS (5mm X 7.5mm) IN ACCORDANCE WITH THE INTERNATIONAL GRID DETAILED IN THE IEC PUBLICATION 97.

① CONTROLLING DIMENSIONS: MILLIMETERS.

Contact Information

Semtech Corporation
 Power Management Products Division
 200 Flynn Road, Camarillo, CA 93012
 Phone: (805)498-2111 FAX (805)498-3804

Компания «Life Electronics» занимается поставками электронных компонентов импортного и отечественного производства от производителей и со складов крупных дистрибьюторов Европы, Америки и Азии.

С конца 2013 года компания активно расширяет линейку поставок компонентов по направлению коаксиальный кабель, кварцевые генераторы и конденсаторы (керамические, пленочные, электролитические), за счёт заключения дистрибьюторских договоров

Мы предлагаем:

- Конкурентоспособные цены и скидки постоянным клиентам.
- Специальные условия для постоянных клиентов.
- Подбор аналогов.
- Поставку компонентов в любых объемах, удовлетворяющих вашим потребностям.
- Приемлемые сроки поставки, возможна ускоренная поставка.
- Доставку товара в любую точку России и стран СНГ.
- Комплексную поставку.
- Работу по проектам и поставку образцов.
- Формирование склада под заказчика.
- Сертификаты соответствия на поставляемую продукцию (по желанию клиента).
- Тестирование поставляемой продукции.
- Поставку компонентов, требующих военную и космическую приемку.
- Входной контроль качества.
- Наличие сертификата ISO.

В составе нашей компании организован Конструкторский отдел, призванный помогать разработчикам, и инженерам.

Конструкторский отдел помогает осуществить:

- Регистрацию проекта у производителя компонентов.
- Техническую поддержку проекта.
- Защиту от снятия компонента с производства.
- Оценку стоимости проекта по компонентам.
- Изготовление тестовой платы монтаж и пусконаладочные работы.



Тел: +7 (812) 336 43 04 (многоканальный)
Email: org@lifeelectronics.ru