

PmodCLS™ Serial LCD Display Module Reference Manual

Revision: December 14, 2007

Note: This document applies to REV D-E of the board.

215 E Main Suite D | Pullman, WA 99163
(509) 334 6306 Voice and Fax

Overview

The PmodCLS module can be used to display important information during program development or as a user interface after the project has been completed. The module is ideally suited for projects that include a Digilent embedded-AVR board, but can also be used in projects using a Digilent FPGA board.

The module is capable of executing a variety of instructions, such as erasing specific characters, setting different display modes, scrolling, and displaying user-defined characters. These instructions are specified using escape sequences to send commands to the board's embedded Atmel ATmega48 microcontroller. The display on the module is driven by this AVR and controls all of the features of the board.

Functional Description

Communication with the embedded AVR on the PmodCLS is established using a UART, SPI, or TWI (Phillips I²C compatible) serial connection. Characters are written to the display simply by sending characters over the communication link. The characters appear on the display at the current location of the board's cursor.

You set the cursor location, and send other instructions, by sending escape sequences. An escape sequence is specified by first sending the escape character followed by a left square bracket '[', zero or more numeric parameters separated by semicolons ';', followed by the command character for the specific command.. All of the possible instructions are listed in the "Instruction Set" section, below.

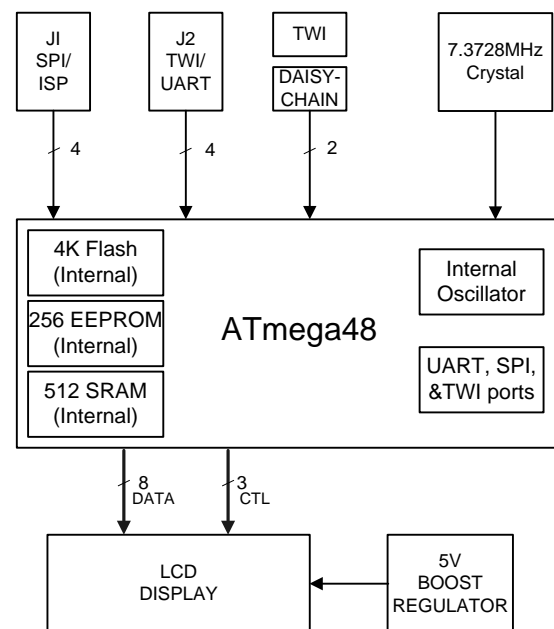
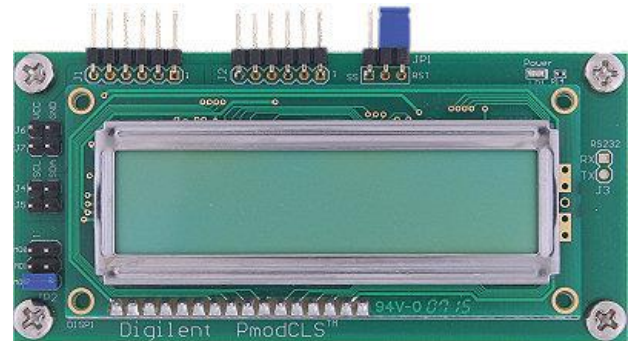

PmodCLS Block Diagram

Communication Options

You can set the board's communication method by setting the mode jumpers MD0, MD1, and MD2 on the board. Possible mode jumper configurations are listed in the table below. For Rev D boards, a missing jumper is represented by 0 and a connected jumper is represented by 1. For Rev E boards, a missing

jumper is represented by 1 and a connected jumper is represented by 0.

MD2, MD1, MD0	Protocol	Details
0,0,0	UART	2400 baud
0,0,1	UART	4800 baud
0,1,0	UART	9600 baud
0,1,1	UART	baud rate in EEPROM
1,0,0	TWI	address: 0x48
1,0,1	TWI	address in EEPROM
1,1,0	SPI	
1,1,1	specified in EEPROM	specified in EEPROM

Connector J1 is used for SPI communication. Connector J2 can either be used for UART or TWI communication. Connectors J4 and J5 can be used to daisy chain other TWI devices.

Power Supply Options

The module is rated for external power ranging from 2.7 to 5.5 volts DC. Using voltage outside this range could damage the PmodCLS and connected devices. The PmodCLS can be powered through the board's 6-pin headers J1 or J2, or through connectors J6 or J7.

When the module is connected to another Digilent microcontroller or FPGA board, that board can power the PmodCLS through a Pmod connector. The host board should be jumpered to provide 3.3V on the VCC pin of the connector being used. The module is then powered by the host board's power supply.

Instruction Set

The PmodCLS is capable of executing many different instructions. Instructions are sent using escape sequences. An escape sequence begins with the ESC character (character code 0x1B or decimal 27), followed by the left square bracket '[', followed by 0 or more parameters separated by semicolons ';' and ending with the command character. Command characters are case sensitive.

Instruction	Result
<row>;<col>H	set cursor position to <row>,<col>
s	save cursor position
u	restore saved cursor position
j	clear display and home cursor
<ps>K	erase within line 0 = current position to end of line 1 = start of line to current position 2 = entire line
<ps>N	erase field in current line <ps> = number of chars starting at current position
<pn>@	scroll left <pn> columns
<pn>A	scroll right <pn> columns
*	reset; equivalent to cycling power of PmodCLS
<ps>h	set display mode 0 = wrap line at 16 characters 1 = wrap line at 40 characters
<ps>c	set cursor mode 0 = cursor off 1 = cursor on, blink off 2 = cursor on, blink on
<pn>a	save TWI address in EEPROM to <pn>
<pn>b	save baud rate value in EEPROM to <pn>
<pt>p	program character table into LCD
Instruction	Result
<pt>t	save RAM character table to EEPROM
<pt>l	load EEPROM character table to RAM
<pn>...<pn>;<ps>d	define user programmable character
<ps>m	save communication mode to EEPROM

w	enable write to EEPROM
<ps>n	save cursor mode to EEPROM
<ps>o	save display mode to EEPROM

Symbol	Definition
<pr>	row number (0 - 1)
<pc>	column number (0 – 39)
<pn>	numeric parameter (decimal, hex, or binary)
<ps>	decimal selection parameter
<pt>	character table selector (0 – 2 in EEPROM, 3 in RAM)

EEPROM

Before you can store any value to an address in EEPROM, writing to EEPROM must first be enabled. The command to enable writing to the EEPROM must be sent before each successive write to EEPROM. If the command to enable writing to the EEPROM is not sent before an EEPROM-related command, the command will be ignored.

Custom Characters

The module can display up to eight custom characters at a time, but is capable of storing four sets of eight characters. This consists of three stored character tables in EEPROM and one table loaded into the LCD's RAM.

To create a new custom character, send the command *(ESC)[<pn>...<pn>;<ps>d* where <pn> is a numeric parameter that describes a row in the character and <ps> is a decimal selection parameter (0 through 7.) A custom character definition contains eight rows, so the escape sequence to define one must have eight <pn> values followed by the <ps> value that specifies the character being defined.

To create a new character, first draw out the pattern. Then, determine the numerical value of each row in the character. Note that the left-most segment is the most significant bit. Record each row, from top to bottom, and record which character in the table to save it to. Each row of the character contains six pixels, so only the low six bits of each byte value are used.

For example, the following character would be saved by writing:

```
lcdChar(0x1B);
lcdString("[14;31;21;31;23;16;31;14;0d");
```

where lcdChar() and lcdString() are functions that write characters and arrays of characters.

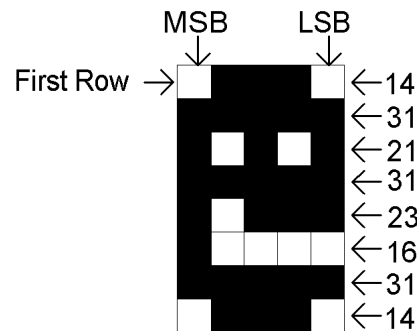

The above command saves the character to the '0' address in the LCD's RAM table. To display this character, send the numerical value of the addressed character. In this example, it is performed by writing *lcdChar(0x00);*

The character will appear at the location of the LCD's cursor.

Connector J1 – SPI Communications		
Pin	Signal	Description
1	SS/RST	Slave Select
2	MOSI	Master out/Slave in Data
3	MISO	Master in/ Slave out Data
4	SCK	Serial Clock
5	GND	Power supply ground
6	VCC	Power supply (3.3V)

Connector J2 – UART/TWI Communications		
Pin	Signal	Description
1	SCL	TWI clock
2	SDA	TWI data
3	TXD	UART transmit data
4	RXD	UART receive data
5	GND	Power supply ground
6	VCC	Power supply (3.3V)

Connector J4 & J5 – TWI Daisy Chain		
Pin	Signal	Description
1	SCL	TWI clock
2	SDA	TWI data

Компания «Life Electronics» занимается поставками электронных компонентов импортного и отечественного производства от производителей и со складов крупных дистрибьюторов Европы, Америки и Азии.

С конца 2013 года компания активно расширяет линейку поставок компонентов по направлению коаксиальный кабель, кварцевые генераторы и конденсаторы (керамические, пленочные, электролитические), за счёт заключения дистрибьюторских договоров

Мы предлагаем:

- Конкурентоспособные цены и скидки постоянным клиентам.
- Специальные условия для постоянных клиентов.
- Подбор аналогов.
- Поставку компонентов в любых объемах, удовлетворяющих вашим потребностям.
- Приемлемые сроки поставки, возможна ускоренная поставка.
- Доставку товара в любую точку России и стран СНГ.
- Комплексную поставку.
- Работу по проектам и поставку образцов.
- Формирование склада под заказчика.
- Сертификаты соответствия на поставляемую продукцию (по желанию клиента).
- Тестирование поставляемой продукции.
- Поставку компонентов, требующих военную и космическую приемку.
- Входной контроль качества.
- Наличие сертификата ISO.

В составе нашей компании организован Конструкторский отдел, призванный помогать разработчикам, и инженерам.

Конструкторский отдел помогает осуществить:

- Регистрацию проекта у производителя компонентов.
- Техническую поддержку проекта.
- Защиту от снятия компонента с производства.
- Оценку стоимости проекта по компонентам.
- Изготовление тестовой платы монтаж и пусконаладочные работы.



Тел: +7 (812) 336 43 04 (многоканальный)

Email: org@lifeelectronics.ru