

2 A max constant current LED driver

Features

- Up to 40 V input voltage
- Less than 0.5 V voltage overhead
- Up to 2 A output current
- PWM dimming pin
- Shutdown pin
- LED disconnection diagnostic
- Slope control with external cap

Applications

- LED constant current supplying for varying input voltages
- Low voltage lighting
- Small appliances LED lighting
- Car LED lights

Description

The STCS2A is a BiCMOS constant current source designed to provide a precise constant current starting from a varying input voltage source. The main target is to replace discrete components

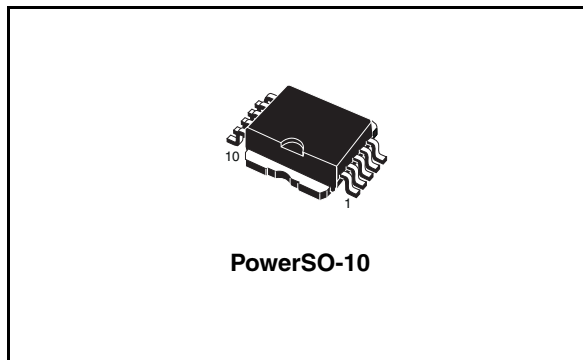

solution for driving LEDs in low voltage applications such as 5 V, 12 V or 24 V giving benefits in terms of precision, integration and reliability.

The current is set with external resistor up to 2 A with a $\pm 10\%$ precision; a dedicated pin allows implementing PWM dimming. An external capacitor allows setting the slope for the current rise from tens of microseconds to tens of milliseconds allowing reduction of EMI.

An open-drain pin output provides information on load disconnection condition.

Table 1. Device summary

Order code	Package	Packaging
STCS2ASPR	PowerSO-10	600 parts per reel

Contents

1	Application diagram	3
2	Pin configuration	4
3	Maximum ratings	5
4	Electrical characteristics	6
5	Timing	7
6	Typical performance characteristics	8
7	Detail description	10
	7.1 Current setting	10
	7.2 Enable	10
	7.3 PWM dimming	10
	7.4 Diagnostic	11
8	Application information	12
	8.1 Reverse polarity protection	12
	8.2 Thermal considerations	12
9	Package mechanical data	14
10	Revision history	17

1 Application diagram

Figure 1. Typical application diagram for 2 A LED current

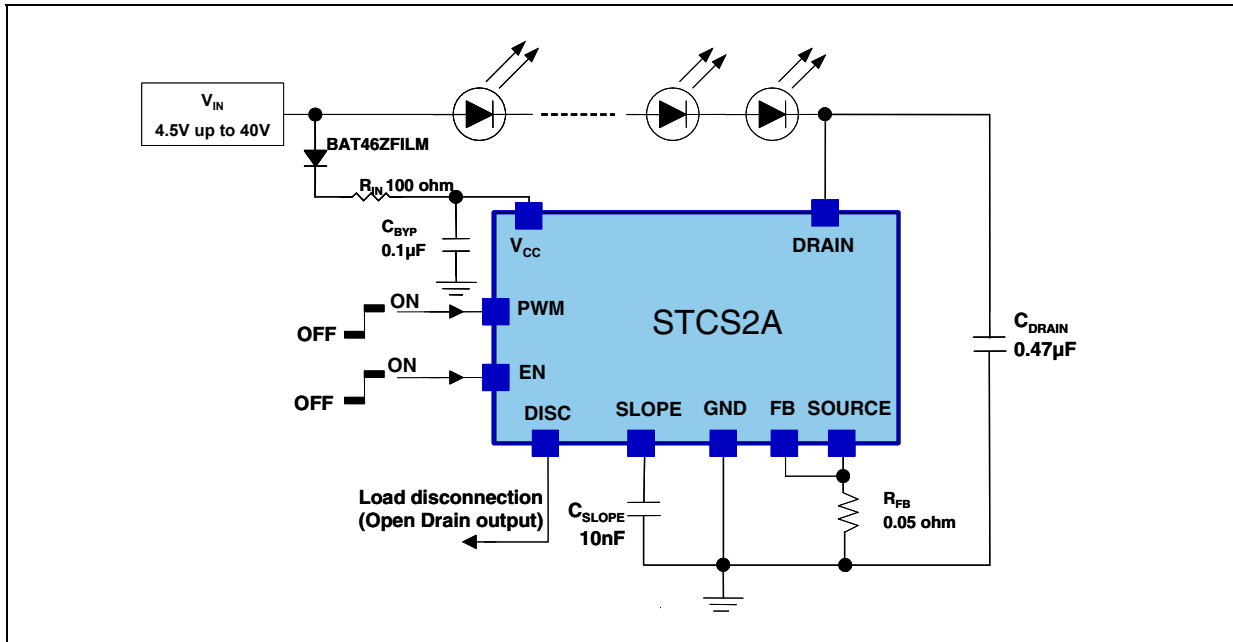

2 Pin configuration

Figure 2. Pin connections (top view)

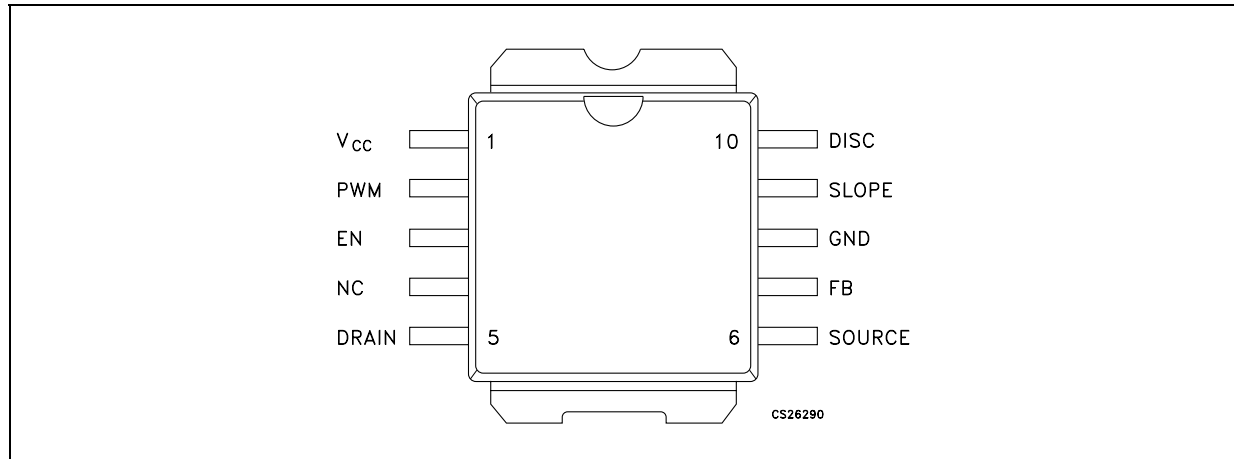

Table 2. Pin description

Pin n°	Symbol	Note
1	V _{CC}	Supply voltage
2	PWM	PWM dimming input
3	EN	Shutdown
4	NC	No connect
5	DRAIN	Internal N-MOSFET drain
6	SOURCE	Internal N-MOSFET source. Reference voltage is 100 mV. An external resistor between SOURCE and GND pins sets different current levels for different application needs
7	FB	Feedback input. The control loop regulates the current in such a way that the average voltage at the FB input is 100 mV (nominal). The cathode of the LED and a resistor to ground to set the LED current should be connected at this point
8	GND	Ground
9	SLOPE	Capacitor for slope control
10	DISC	Load disconnection flag (open drain)
	exp-pad	Internally connected to ground

3 Maximum ratings

Table 3. Absolute maximum ratings

Symbol	Parameter	Value	Unit
V_{CC}	DC supply voltage	-0.3 to +45	V
DRAIN	Drain pin	-0.3 to +45	
SOURCE	Source pin	-0.3 to + 3.3	V
PWM, EN, DISC	Logic pins	-0.3 to + $V_{CC} + 3.3$	V
SLOPE, FB	Configuration pins	-0.3 to + 3.3	V
ESD	Human body model (all pins)	± 2	kV
$T_J^{(1)}$	Junction temperature	-40 to 150	$^{\circ}\text{C}$
T_{STG}	Storage temperature range	-55 to 150	$^{\circ}\text{C}$

1. T_J is calculated from the ambient temperature T_A and the power dissipation P_D according the following formula:
 $T_J = T_A + (P_D \times R_{thJA})$. See [Figure 16](#). for details of max power dissipation for ambient temperatures higher than 25 $^{\circ}\text{C}$.

Note: Absolute maximum ratings are those values beyond which damage to the device may occur. Functional operation under these conditions is not implied.

Table 4. Thermal data

Symbol	Parameter	PowerSO-10	Unit
R_{thJC}	Thermal resistance junction-case	2	$^{\circ}\text{C}/\text{W}$
$R_{thJA}^{(1)}$	Thermal resistance junction-ambient ⁽¹⁾	50	$^{\circ}\text{C}/\text{W}$
$R_{thJA}^{(2)}$	Thermal resistance junction-ambient ⁽²⁾	35	$^{\circ}\text{C}/\text{W}$
$R_{thJA}^{(3)}$	Thermal resistance junction-ambient ⁽³⁾	12	$^{\circ}\text{C}/\text{W}$

- FR4 with using the recommended pad-layout
- FR4 with heat sink on board (6 cm²).
- FR4 with copper-filled through holes and external heat sink applied.

4 Electrical characteristics

Table 5. Electrical characteristics ($V_{CC} = 12\text{ V}$; $I_O = 100\text{ mA}$; $T_J = -40\text{ }^\circ\text{C}$ to $125\text{ }^\circ\text{C}$; $V_{DRAIN} = 1\text{ V}$; $C_{DRAIN} = 1\text{ }\mu\text{F}$; $C_{BYP} = 100\text{ nF}$ typical values are at $T_A = 25\text{ }^\circ\text{C}$, unless otherwise specified)

Symbol	Parameter	Test conditions	Min.	Typ.	Max.	Unit
V_{CC}	Supply voltage range		4.5		40	V
	Output current range		1		2000	mA
I_O	Output current	$R_{FB} = 50\text{ m}\Omega$		2		A
	Regulation (percentage with respect to $V_{CC} = 12\text{ V}$)	$V_{CC} = 4.5\text{ to }40\text{ V}$, $I_O = 100\text{ mA}$; $V_{DRAIN} = 1\text{ V}$	-1		+1	%
V_{FB}	Feedback voltage	$I_O = 0\text{ to }2\text{ A}$	90	100	110	mV
I_{CC}	Quiescent current (Measured on V_{CC} pin)	On Mode		450	750	μA
		Shutdown Mode; $V_{CC} = 5\text{ to }12\text{ V}$			1	
		Shutdown Mode; $V_{CC} = 12\text{ to }40\text{ V}$			3	
V_{DROP}	Dropout voltage (V_{DRAIN} to GND)	$I_O = 100\text{ mA}$		0.12	0.16	V
		$I_O = 2\text{ A}$		0.58	0.9	
$LEAK_{DRAIN}$	Drain leakage current	Shutdown; $V_{DRAIN} = 40\text{ V}$			10	μA
T_R/T_F	Rise/Fall time of the current on PWM transition	$C_{SLOPE} = 10\text{ nF}$, $T_J = -40\text{ }^\circ\text{C}$ to $105\text{ }^\circ\text{C}$		800		μs
T_D	Delay on PWM signal (<i>Figure 1</i>)	V_{PWM} rising, $V_{CC} = 12\text{ V}$ $C_{SLOPE} = \text{floating}$		3		μs
		V_{PWM} falling, $V_{CC} = 12\text{ V}$ $C_{SLOPE} = \text{floating}$		1.2		
DISC	Low level voltage	$I_{SINK} = 5\text{ mA}$		0.2	0.5	V
	Leakage current	$V_{DISC} = 5\text{ V}$			1	μA
	Load disconnection threshold (V_{DRAIN} -GND)	DISC Turn-ON			75	mV
		DISC Turn-OFF			110	
Thermal Protection	Shutdown temperature			155		$^\circ\text{C}$
	Hysteresis			25		
Logic inputs (PWM and EN)						
V_L	Input low level				0.4	V
V_H	Input high level		1.2			V
	EN, PWM leakage current	$V_{EN} = 5\text{ V}$; $V_{PWM} = 5\text{ V}$			2	μA
	EN input leakage current	$V_{EN} = 40\text{ V}$			60	
	PWM input leakage current	$V_{PWM} = 40\text{ V}$			120	

Note: All devices 100 % production tested at $T_A = 25\text{ }^\circ\text{C}$. Limits over the operating temperature range are guaranteed by design.

5 Timing

Figure 3. PWM and output current timing



Figure 4. Block diagram

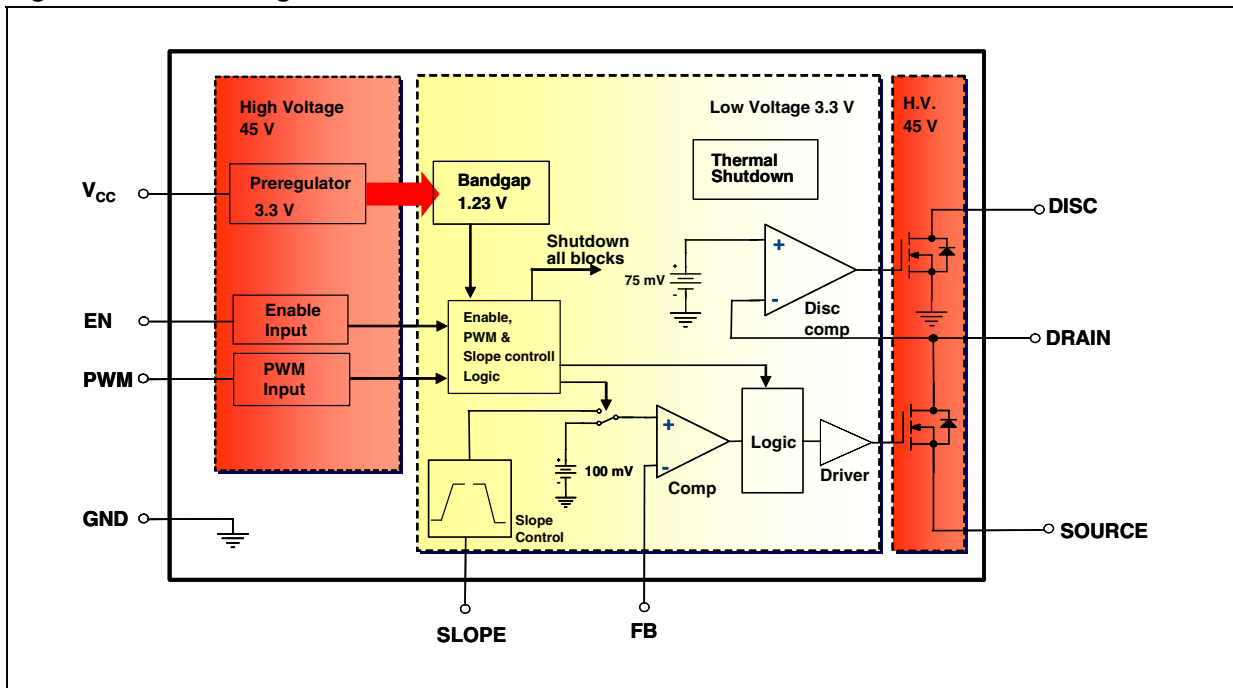

6 Typical performance characteristics

Figure 5. I_{DRAIN} vs V_{CC} , $T_A = 25^\circ C$



Figure 6. I_{DRAIN} vs R_{SET}



Figure 7. I_{DRAIN} vs temperature



Figure 8. V_{DROP} (including V_{FB}) vs temperature



Figure 9. I_{CC} vs temperature



Figure 10. I_{CC} vs V_{CC}



Figure 11. T_{rise}/T_{fall} vs C_{SLOPE}

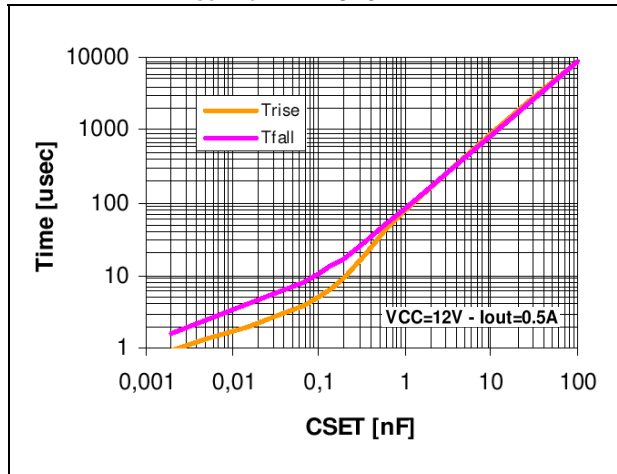

Figure 12. Turn-on time

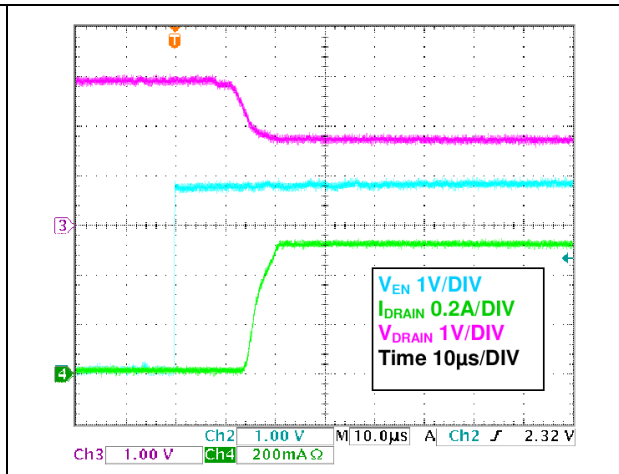

Figure 13. Dimming operation: Rise

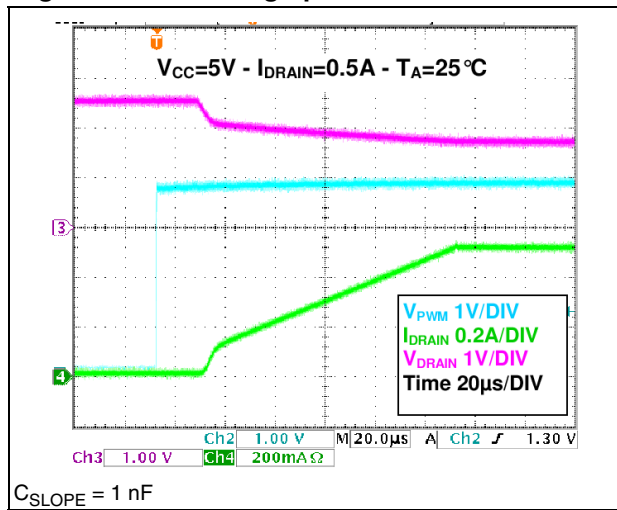
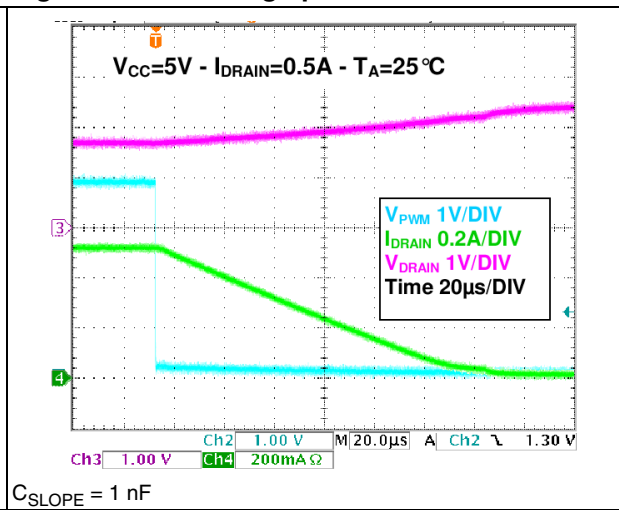

Figure 14. Dimming operation: Fall



7 Detail description

The STCS2A is a BiCMOS constant current source designed to provide a precise constant current starting from a varying input voltage source. The main target is to replace discrete components solution for driving LEDs in low voltage applications such as 5 V, 12 V or 24 V giving benefits in terms of precision, integration and reliability.

7.1 Current setting

The current is set with an external sensing resistor connected to the FB pin. The feedback voltage is 100 mV, then a low resistor value can be chosen reducing power dissipation. A value between 1 mA and 2 A can be set according to the resistor value the resulting output current has a tolerance of $\pm 10\%$.

For instance, should one need a 700 mA LEDs current, R_F should be selected according to the following equation:

$$R_F = V_{FB} / I_{LEDs} = 100 \text{ mV} / 700 \text{ mA} = 142 \text{ m}\Omega$$

7.2 Enable

When the enable pin is low the device completely off thus reducing current consumption to less than 1 μ A. When in shutdown mode, the internal main switch is off.

7.3 PWM dimming

The PWM input allows implementing PWM dimming on the LED current; when the PWM input is high the main switch will be on and vice versa. A typical frequency range for the input is from few Hertz to 50 kHz. The maximum dimming frequency is limited by the minimum rise/fall time of the current (obtained with $C_{SLOPE}=0$) which is around 4 μ s each. Above 50 kHz the current waveforms starts assuming a triangular shape.

While the PWM input is switching, the overall circuitry remains on, this is needed in order to implement two important features: short delay time and controlled slope for the current.

Since the PWM pin is controlling just the main switch, the overall circuitry is always on and it is able to control the delay time between the PWM input signal and the output current in the range of few μ s, this is important to implement synchronization among several light LED sources.

The rise and fall slope of the current is controlled by the C_{SLOPE} capacitor. The rise and fall time are linear dependent from the C_{SLOPE} capacitor value (see graph in typical characteristics). A controlled rise time has two main benefits: reducing EMI noise and avoid current spike at turn on.

When C_{SLOPE} is left floating, the internal switch is turned on at maximum speed, in this condition an overshoot can be present on the LED current before the system goes into regulation.

7.4 Diagnostic

When STCS2A is in on mode (EN is high), the device is able to detect disconnection or fail of the LED string monitoring V_{DRAIN} pin. If V_{DRAIN} is lower than 75 mV the DISC pin is pulled low regardless the PWM pin status. This information can be used by the system to inform that some problem happens in the LEDs.

8 Application information

8.1 Reverse polarity protection

STCS2A must be protected from reverse connection of the supply voltage. Since the current sunk from V_{CC} pin is in the range of $450 \mu\text{A}$ a small diode connected to V_{CC} is able to protect the chip. Care must be taken for the whole application circuit, especially for the LEDs, in fact, in case a negative voltage is applied between V_{IN} and GND, a negative voltage will be applied to the LED string that must have a total breakdown voltage higher than the negative applied voltage in order to avoid any damage.

Figure 15. Reverse polarity condition

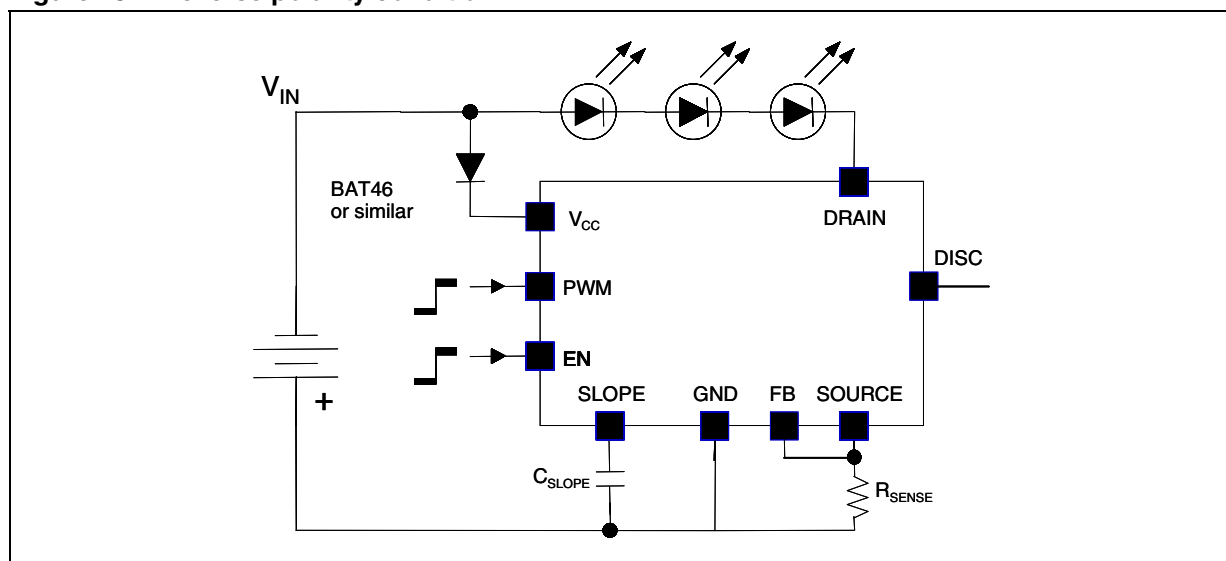

8.2 Thermal considerations

The STCS2A is able to control a LED current up to 2 A and able to sustain a voltage on the drain pin up to 40 V. Those operating conditions are however limited by thermal constraints.

The poor thermal conduction of epoxy FR4 boards does not permit to benefit of the outstanding thermal performance of the PowerSO-10.

In any case one way to improve the thermal conduction is the use of large heat spreader areas at the copper layer of the PC board. This leads to a reduction of thermal resistance to $30 - 36 \text{ }^\circ\text{C/W}$ for $3 \text{ to } 6 \text{ cm}^2$ on-board heatsink.

Use of copper-filled through holes on conventional FR4 techniques increases the metallization and decreases thermal resistance accordingly. Using a configuration with 16 holes under the spreader of the package with a pitch of 1.8 mm and a diameter of 0.7 mm, the thermal resistance (junction - heatsink) can be reduced to $12 \text{ }^\circ\text{C/W}$.

The thermal resistances shown in the Error! Reference source not found. section are the typical ones.

The power dissipation in the device can be calculated as follow:

$$P_D = (V_{DRAIN} - V_{FB}) \times I_{LED} + (V_{CC} \times I_{CC})$$

basing on this and on the thermal resistance and ambient temperature, the junction temperature can be calculated as:

$$T_J = R_{thJA} \times P_D + T_A$$

A typical application could be:

- Input voltage: 12 V;
- 3 white LEDs with an typical $V_F = 3.6$ V;
- LEDs current: 1000 mA;
- Package: PowerSO-10;
- $T_A = 50$ °C;

In this case the drain voltage is given by:

$$V_{DRAIN} = 12 - 3 \times 3.6 = 1.2 \text{ V}$$

end the power dissipated in the IC is the following:

$$P_D = (1.2 - 0.1) \times 1 + 12 \times 0.5 \times 10^{-3} = 1.1 \text{ W}$$

With a thermal resistance junction-ambient equal to 12 °C/W the junction temperature is:

$$T_J = 12 \times 1.1 + 50 = 63 \text{ °C.}$$

The following pictures show the maximum power dissipation according to the ambient temperature:

Figure 16. Maximum power dissipation vs T_A for PowerSO-10

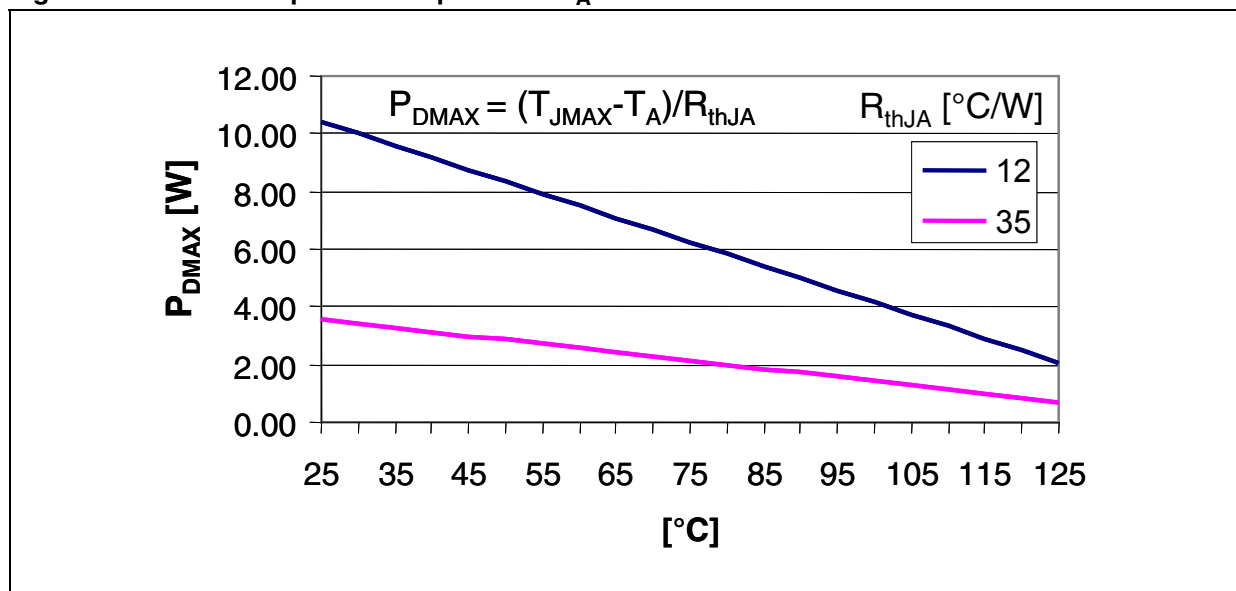

9 Package mechanical data

In order to meet environmental requirements, ST offers these devices in ECOPACK® packages. These packages have a lead-free second level interconnect. The category of second Level Interconnect is marked on the package and on the inner box label, in compliance with JEDEC Standard JESD97. The maximum ratings related to soldering conditions are also marked on the inner box label. ECOPACK is an ST trademark. ECOPACK specifications are available at: www.st.com.

PowerSO-10 Mechanical Data

Dim.	mm.			inch.		
	Min.	Typ.	Max.	Min.	Typ.	Max.
A			3.70			0.146
A1			0.10			0.004
A2	3.40		3.60	0.134		0.142
A3	1.25		1.35	0.049		0.053
b	0.40		0.53	0.016		0.021
c	0.35		0.55	0.014		0.022
D	9.40		9.60	0.370		0.378
D1	7.40		7.60	0.291		0.299
E	13.80		14.40	0.543		0.567
E1	9.30		9.50	0.366		0.374
E2	7.20		7.60	0.283		0.299
E3	5.90		6.10	0.232		0.240
e		1.27			0.050	
L	0.95		1.65	0.037		0.065
α	0°		8°	0°		8°

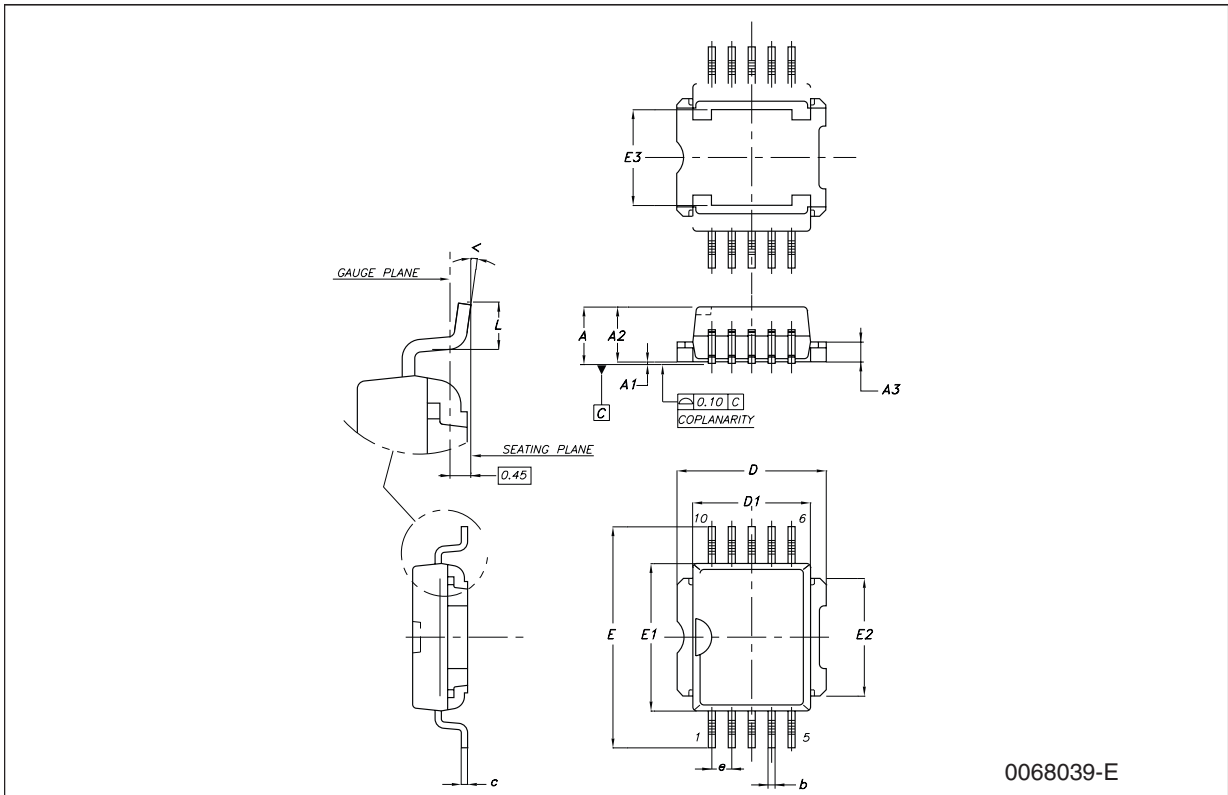

0068039-E

Tape & Reel PowerSO-10 Mechanical Data

Dim.	mm.			inch.		
	Min.	Typ.	Max.	Min.	Typ.	Max.
A			330			12.992
C	12.8		13.2	0.504		0.519
D	20.2			0.795		
N	60			2.362		
T			30.4			1.197
Ao	14.9		15.1	0.587		0.594
Bo	9.9		10.1	0.390		0.398
Ko	4.15		4.35	0.163		0.171
Po	3.9		4.1	0.153		0.161
P	23.9		24.1	0.941		0.949
W	23.7		24.3	0.933		0.957

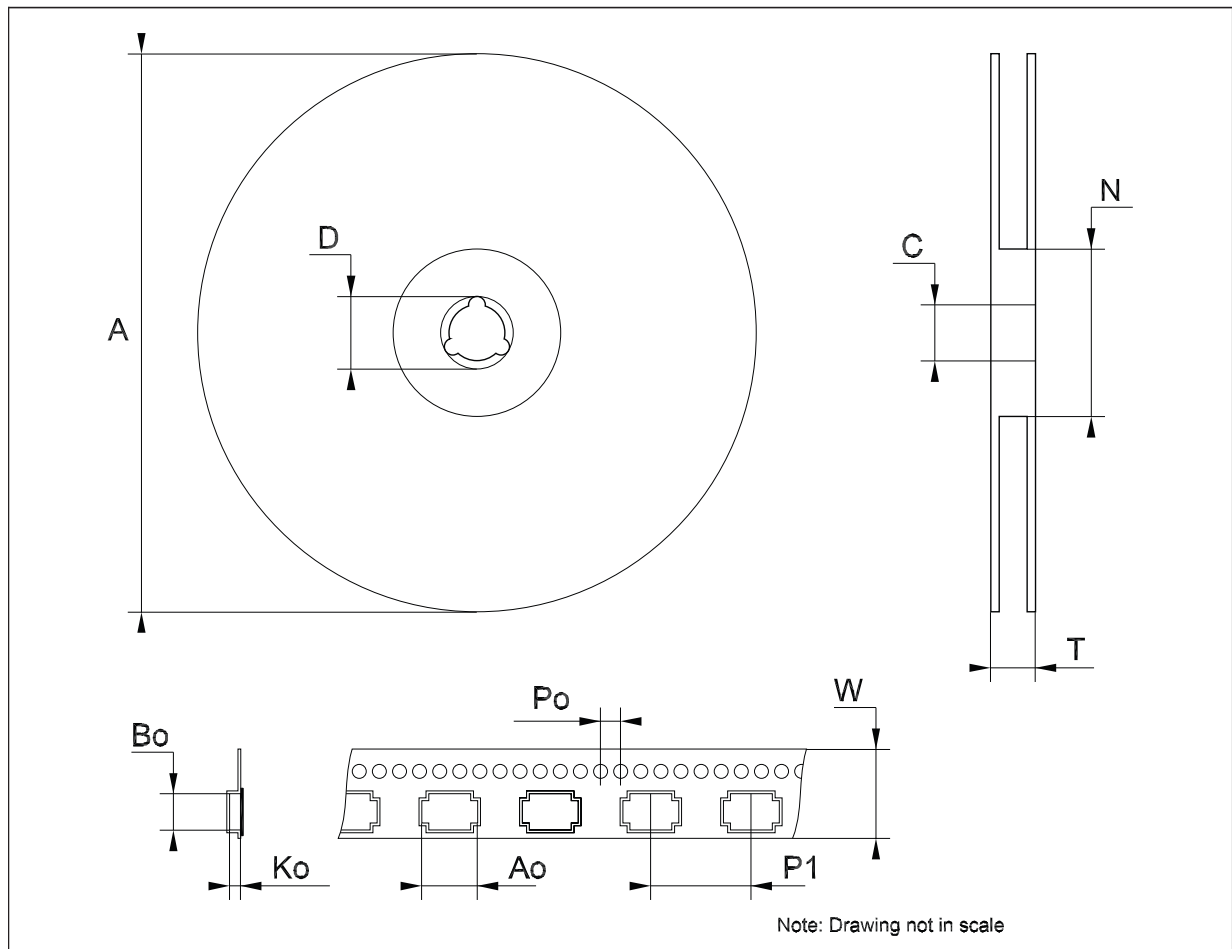

10 Revision history

Table 6. Document revision history

Date	Revision	Changes
19-Feb-2008	1	Initial release.
28-May-2008	2	Modified: Table 3 on page 5.
02-Jul-2008	3	Modified: Table 5 on page 6.

Please Read Carefully:

Information in this document is provided solely in connection with ST products. STMicroelectronics NV and its subsidiaries ("ST") reserve the right to make changes, corrections, modifications or improvements, to this document, and the products and services described herein at any time, without notice.

All ST products are sold pursuant to ST's terms and conditions of sale.

Purchasers are solely responsible for the choice, selection and use of the ST products and services described herein, and ST assumes no liability whatsoever relating to the choice, selection or use of the ST products and services described herein.

No license, express or implied, by estoppel or otherwise, to any intellectual property rights is granted under this document. If any part of this document refers to any third party products or services it shall not be deemed a license grant by ST for the use of such third party products or services, or any intellectual property contained therein or considered as a warranty covering the use in any manner whatsoever of such third party products or services or any intellectual property contained therein.

UNLESS OTHERWISE SET FORTH IN ST'S TERMS AND CONDITIONS OF SALE ST DISCLAIMS ANY EXPRESS OR IMPLIED WARRANTY WITH RESPECT TO THE USE AND/OR SALE OF ST PRODUCTS INCLUDING WITHOUT LIMITATION IMPLIED WARRANTIES OF MERCHANTABILITY, FITNESS FOR A PARTICULAR PURPOSE (AND THEIR EQUIVALENTS UNDER THE LAWS OF ANY JURISDICTION), OR INFRINGEMENT OF ANY PATENT, COPYRIGHT OR OTHER INTELLECTUAL PROPERTY RIGHT.

UNLESS EXPRESSLY APPROVED IN WRITING BY AN AUTHORIZED ST REPRESENTATIVE, ST PRODUCTS ARE NOT RECOMMENDED, AUTHORIZED OR WARRANTED FOR USE IN MILITARY, AIR CRAFT, SPACE, LIFE SAVING, OR LIFE SUSTAINING APPLICATIONS, NOR IN PRODUCTS OR SYSTEMS WHERE FAILURE OR MALFUNCTION MAY RESULT IN PERSONAL INJURY, DEATH, OR SEVERE PROPERTY OR ENVIRONMENTAL DAMAGE. ST PRODUCTS WHICH ARE NOT SPECIFIED AS "AUTOMOTIVE GRADE" MAY ONLY BE USED IN AUTOMOTIVE APPLICATIONS AT USER'S OWN RISK.

Resale of ST products with provisions different from the statements and/or technical features set forth in this document shall immediately void any warranty granted by ST for the ST product or service described herein and shall not create or extend in any manner whatsoever, any liability of ST.

ST and the ST logo are trademarks or registered trademarks of ST in various countries.

Information in this document supersedes and replaces all information previously supplied.

The ST logo is a registered trademark of STMicroelectronics. All other names are the property of their respective owners.

© 2008 STMicroelectronics - All rights reserved

STMicroelectronics group of companies

Australia - Belgium - Brazil - Canada - China - Czech Republic - Finland - France - Germany - Hong Kong - India - Israel - Italy - Japan - Malaysia - Malta - Morocco - Singapore - Spain - Sweden - Switzerland - United Kingdom - United States of America

www.st.com

Компания «Life Electronics» занимается поставками электронных компонентов импортного и отечественного производства от производителей и со складов крупных дистрибьюторов Европы, Америки и Азии.

С конца 2013 года компания активно расширяет линейку поставок компонентов по направлению коаксиальный кабель, кварцевые генераторы и конденсаторы (керамические, пленочные, электролитические), за счёт заключения дистрибьюторских договоров

Мы предлагаем:

- Конкурентоспособные цены и скидки постоянным клиентам.
- Специальные условия для постоянных клиентов.
- Подбор аналогов.
- Поставку компонентов в любых объемах, удовлетворяющих вашим потребностям.
- Приемлемые сроки поставки, возможна ускоренная поставка.
- Доставку товара в любую точку России и стран СНГ.
- Комплексную поставку.
- Работу по проектам и поставку образцов.
- Формирование склада под заказчика.
- Сертификаты соответствия на поставляемую продукцию (по желанию клиента).
- Тестирование поставляемой продукции.
- Поставку компонентов, требующих военную и космическую приемку.
- Входной контроль качества.
- Наличие сертификата ISO.

В составе нашей компании организован Конструкторский отдел, призванный помогать разработчикам, и инженерам.

Конструкторский отдел помогает осуществить:

- Регистрацию проекта у производителя компонентов.
- Техническую поддержку проекта.
- Защиту от снятия компонента с производства.
- Оценку стоимости проекта по компонентам.
- Изготовление тестовой платы монтаж и пусконаладочные работы.



Тел: +7 (812) 336 43 04 (многоканальный)

Email: org@lifeelectronics.ru