



Choose one component from each of the colored sections to assemble a complete switch. For other options or further information please contact EAO Switch directly.

## Product Profile

The Series 92 is an interesting alternative to membrane switching systems. This Series consists of sealed PCB indicators and pushbuttons rugged enough to last for more than 1 million operations.

Technical drawings see pages 83-84

- 1NO (SPST) contacts rated at 42VAC/DC, 50mA
- Standard IP40 and sealed IP67 actuators
- Excellent tactile feel
- Actuators mount in standard 16mm diameter front panel hole
- Optional LED illumination
- Flexible to mount underneath overlay (contact EAO Switch direct for Series 70)

## Indicator



Indicator actuator, white bezel, IP40 front protection, 16mm mounting - Indicator element, mounting flange and LED needed for complete unit

Color	Part No.	Comment
● Red	92-058.200	
● Yellow	92-058.400	
● Green	92-058.500	
○ Clear	92-058.700	With white diffuser



Indicator actuator, black bezel, IP40 front protection, 16mm mounting - Indicator element, mounting flange and LED needed for complete unit

Color	Part No.	Comment
● Red	92-158.200	
● Yellow	92-158.400	
● Green	92-158.500	
○ Clear	92-158.700	With white diffuser

For complete switch also order **A**

For complete switch also order **A**

## Indicator



Indicator actuator, white bezel, IP67 front protection, 16mm mounting - Indicator element, mounting flange and LED needed for complete unit

Color	Part No.	Comment
● Red	92-043.200	
● Yellow	92-043.400	
● Green	92-043.500	
○ Clear	92-043.700	With white diffuser



Indicator actuator, black bezel, IP67 front protection, 16mm mounting - Indicator element, mounting flange and LED needed for complete unit

Color	Part No.	Comment
● Red	92-143.200	
● Yellow	92-143.400	
● Green	92-143.500	
○ Clear	92-143.700	With white diffuser

For complete switch also order **A**

For complete switch also order **A**

## Illuminated pushbutton







Pushbutton actuator, white bezel, IP40 front protection, 16mm mounting - Switch element, mounting flange, and optional LED, needed for complete unit

Color	Part No.	Action	Comment
● Red	92-358.200	Momentary	
● Yellow	92-358.400	Momentary	
● Green	92-358.500	Momentary	
○ Clear	92-358.700	Momentary	With white diffuser

For complete switch also order **A**





Choose one component from each of the colored sections to assemble a complete switch.  
For other options or further information please contact EAO Switch directly.

 BUZZER	 BLOCK	 LED	 ACCESSORIES
--	---	---	---

 Illuminated pushbutton







Pushbutton actuator, black bezel, IP40 front protection, 16mm mounting - Switch element, mounting flange, and optional LED, needed for complete unit

Color	Part No.	Action	Comment
 Red	92-458.200	Momentary	
 Yellow	92-458.400	Momentary	
 Green	92-458.500	Momentary	
 Clear	92-458.700	Momentary	With white diffuser







Pushbutton actuator, white bezel, IP67 front protection, 16mm mounting - Switch element, mounting flange, and optional LED, needed for complete unit

Color	Part No.	Action	Comment
 Red	92-343.200	Momentary	
 Yellow	92-343.400	Momentary	
 Green	92-343.500	Momentary	
 Clear	92-343.700	Momentary	With white diffuser



Pushbutton actuator, black bezel, IP67 front protection, 16mm mounting - Switch element, mounting flange, and optional LED, needed for complete unit

Color	Part No.	Action	Comment
 Red	92-443.200	Momentary	
 Yellow	92-443.400	Momentary	
 Green	92-443.500	Momentary	
 Clear	92-443.700	Momentary	With white diffuser

For complete switch also order  

For complete switch also order  

For complete switch also order  

 Indicator element



Indicator element

Part No.
92-800.042

Switching element



Switching element, 42VAC/DC, 50mA



Part No.	Action	Contact
92-851.342	Momentary	1NO

Mounting flange



Mounting flange required for PCB adaptation

Part No.
92-960.0

For complete switch also order  

For complete switch also order   



Choose one component from each of the colored sections to assemble a complete switch. For other options or further information please contact EAO Switch directly.



T-1 Bi-Pin LED



Spacer, PC board and dismantling tool

Color	Part No.	Voltage	Comment	Drawing	Part No.	Product description
Red	10-2602.3172D	2.2VDC / 20mA	Single-chip	1	92-965.0	Spacer
Orange	10-2602.3173D	2.2VDC / 20mA	Single-chip	2	92-989.0	PC board
Yellow	10-2602.3174D	2.2VDC / 20mA	Single-chip	3	92-971.0	Dismantling tool
Green	10-2602.3175D	2.2VDC / 20mA	Single-chip			
Red	10-5609.3172D	12.0VDC / 20mA	Multi-chip			
Orange	10-5609.3173D	12.0VDC / 20mA	Multi-chip			
Yellow	10-5609.3174D	12.0VDC / 20mA	Multi-chip			
Green	10-5609.3175D	12.0VDC / 20mA	Multi-chip			



## 92 Pushbutton, Indicator

Illuminated, flush mounting, IP40

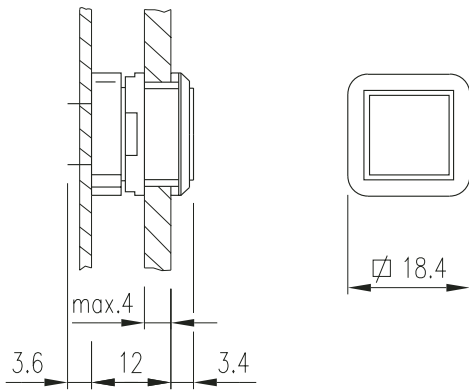

## 92 Pushbutton, Indicator

Illuminated, flush mounting, IP67

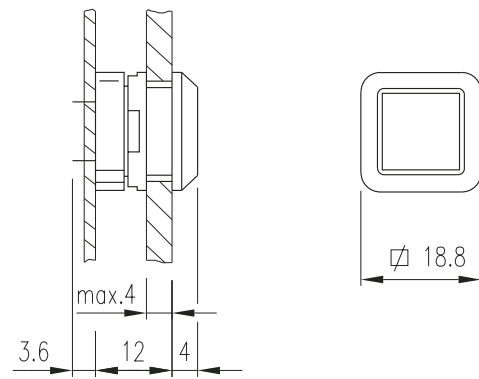

## 92 Switch Element

PCB terminal

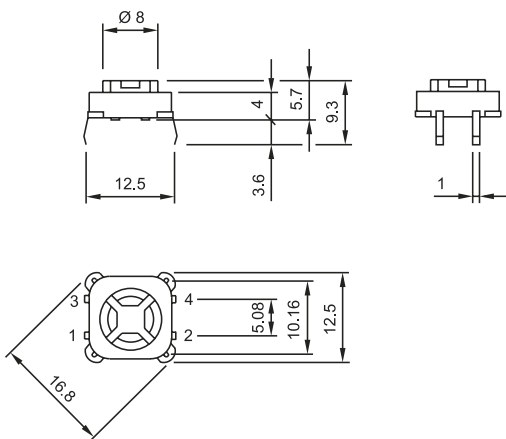

## 92 Indicator Element

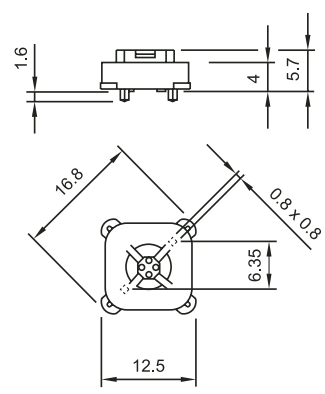

## 92 Mounting Flange

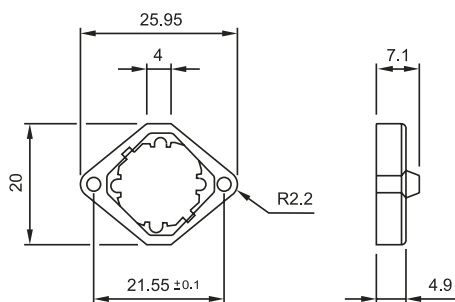

## 92 Cut-outs

Pushbutton, Indicator, IP40 and IP67

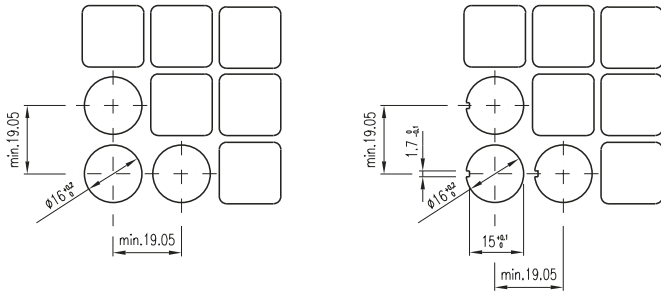

## 92 Switch Element Cut-outs

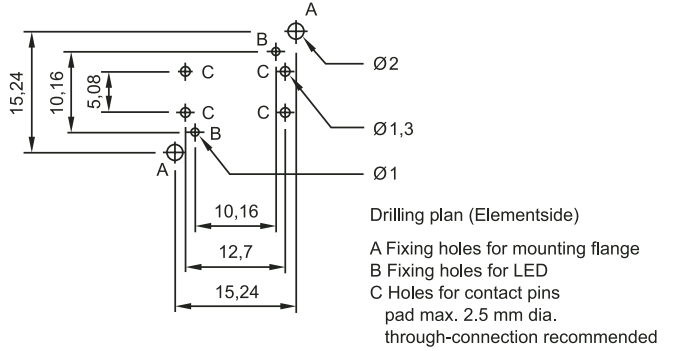

## 92 Indicator Element Cut-outs

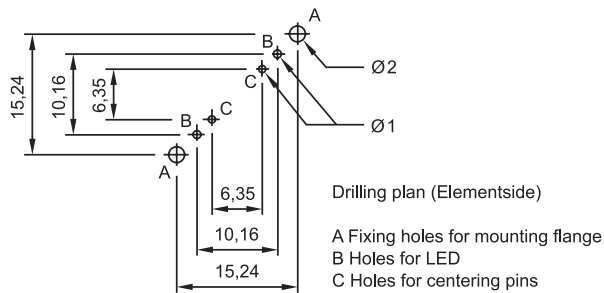

## 92 Array

The positioning and number of mounting flanges is determined by the size of the front panel and PCB. For a consistent tactile operation, position mounting flanges as shown below. Suitable for PCBs of 1.6mm thickness

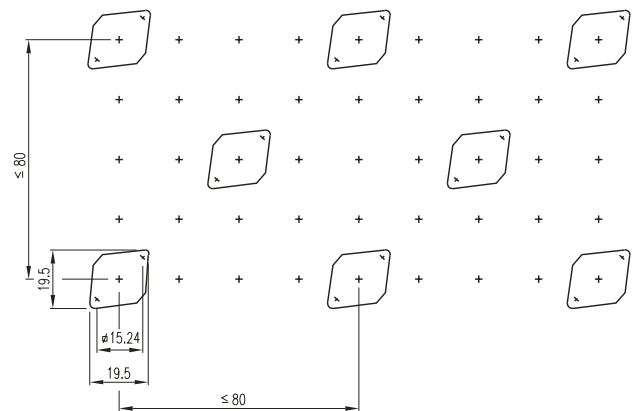

Компания «Life Electronics» занимается поставками электронных компонентов импортного и отечественного производства от производителей и со складов крупных дистрибьюторов Европы, Америки и Азии.

С конца 2013 года компания активно расширяет линейку поставок компонентов по направлению коаксиальный кабель, кварцевые генераторы и конденсаторы (керамические, пленочные, электролитические), за счёт заключения дистрибьюторских договоров

Мы предлагаем:

- Конкурентоспособные цены и скидки постоянным клиентам.
- Специальные условия для постоянных клиентов.
- Подбор аналогов.
- Поставку компонентов в любых объемах, удовлетворяющих вашим потребностям.
- Приемлемые сроки поставки, возможна ускоренная поставка.
- Доставку товара в любую точку России и стран СНГ.
- Комплексную поставку.
- Работу по проектам и поставку образцов.
- Формирование склада под заказчика.
- Сертификаты соответствия на поставляемую продукцию (по желанию клиента).
- Тестирование поставляемой продукции.
- Поставку компонентов, требующих военную и космическую приемку.
- Входной контроль качества.
- Наличие сертификата ISO.

В составе нашей компании организован Конструкторский отдел, призванный помогать разработчикам, и инженерам.

Конструкторский отдел помогает осуществить:

- Регистрацию проекта у производителя компонентов.
- Техническую поддержку проекта.
- Защиту от снятия компонента с производства.
- Оценку стоимости проекта по компонентам.
- Изготовление тестовой платы монтаж и пусконаладочные работы.



Тел: +7 (812) 336 43 04 (многоканальный)  
Email: [org@lifeelectronics.ru](mailto:org@lifeelectronics.ru)