

ON Semiconductor®



KAI-2093 IMAGE SENSOR

1920 (H) X 1080 (V) INTERLINE CCD IMAGE SENSOR



JUNE 11, 2014

DEVICE PERFORMANCE SPECIFICATION

REVISION 1.1 PS-0026



TABLE OF CONTENTS

Summary Specification	5
Description	5
Features	5
Applications	5
Ordering Information	6
Device Description	7
Architecture	7
Pin Description and Physical Orientation	8
Imaging Performance	9
Typical Operational Conditions	9
Optical Specifications	9
CCD Specifications	9
Output Amplifier Specifications	10
General Specifications	10
Typical Performance Curves	11
Monochrome Quantum Efficiency	11
Monochrome with Microlens Angular Quantum Efficiency	11
Color with Microlens Quantum Efficiency	12
Frame Rates	13
Defect Definitions	14
Operational Conditions	14
Specifications	14
Defect Zones	15
Defect Classes	15
KAI-2093-ABA-CB-B1	15
All Other Part Numbers	15
Operation	16
Absolute Maximum Ratings	16
DC Bias Operating Conditions	16
AC Operating Conditions	17
Clock Capacitance	17
Operation Notes	18
Progressive and Interlaced Timing	18
Single Output Mode	18
Dual Output Mode	18
Exposure Control	19
Dark References	19
Connections to the Image Sensor	19
Timing	20
Requirements and Characteristics	20
Frame Timing	21
Frame Timing – Progressive Scan	21
Vertical Clock Edge Alignment	22
Frame Timing – Field Integration Mode	23
Frame Timing – Frame Integration Mode	24
Line Timing	25
Electronic Shutter Timing	26



Storage and Handling27

- Storage Conditions..... 27
- ESD 27
- Cover Glass Care and Cleanliness 27
- Environmental Exposure 27
- Soldering Recommendations 27

Mechanical Drawings28

- Completed Assembly..... 28
- Cover Glass..... 30
 - Clear Cover Glass..... 30
 - Quartz Cover Glass with AR Coatings..... 31
- Glass Transmission 32

Quality Assurance and Reliability33

- Quality and Reliability 33
- Replacement..... 33
- Liability of the Supplier 33
- Liability of the Customer 33
- Test Data Retention..... 33
- Mechanical..... 33

Life Support Applications Policy33

Revision Changes.....34

- MTD/PS-0307 34
- PS-0026 34



TABLE OF FIGURES

Figure 1: Sensor Architecture 7

Figure 2: Package Pin Designations - Top View..... 8

Figure 3: Quantum Efficiency Spectrum for Monochrome Sensors 11

Figure 4: Angular Dependence of Quantum Efficiency..... 11

Figure 5: Quantum Efficiency Spectrum for Color Filter Array Sensors..... 12

Figure 6: Color Filter Array Pattern 12

Figure 7: Progressive Frame Rate vs. HCCD Clock Frequency 13

Figure 8: Defect Zones 15

Figure 9: Progressive Frame Timing..... 21

Figure 10: Ideal Vertical Clock Edge Position 22

Figure 11: Interlaced Frame Timing - Field Integration Mode 23

Figure 12: Interlaced Frame Timing - Frame Integration Mode 24

Figure 13: Line Timing 25

Figure 14: Electronic Shutter Timing Diagram 26

Figure 15: Completed Assembly (1 of 2) 28

Figure 16: Completed Assembly (2 of 2) 29

Figure 17: Clear Cover Glass Drawing 30

Figure 18: Quartz Cover Glass with AR Coating Drawing 31

Figure 19: Cover Glass Transmission 32



Summary Specification

KAI-2093 Image Sensor

DESCRIPTION

The KAI-2093 Image Sensor is a high-performance multi-megapixel image sensor designed for a wide range of medical imaging and machine vision applications.

The 7.4 μm square pixels with microlenses provide high sensitivity and the large full well capacity results in high dynamic range. The split horizontal register offers a choice of single or dual output allowing either 15 or 30 frame per second (fps). The architecture allows for either progressive scan or interlaced readout. The imager features 5 V clocking to facilitate camera design. The vertical overflow drain structure provides antiblooming protection, and enables electronic shuttering for precise exposure control.

FEATURES

- Progressive scan (non-interlaced)
- HCCD and output amplifier capable of 40 MHz operation
- 5 V HCCD clocking
- Single or dual video output operation
- 28 light shielded reference columns per output
- Only 2 vertical CCD clocks and 2 horizontal CCD clocks
- Electronic shutter
- Low Dark Current

APPLICATIONS

- Intelligent Transportation Systems
- Machine Vision
- Surveillance

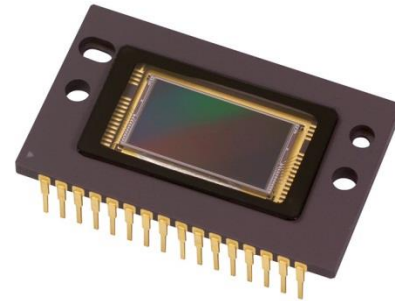

Parameter	Typical Value
Architecture	Interline CCD, Progressive Scan or Interlaced Readout
Total Number of Pixels	1984 (H) x 1092 (V)
Number of Effective Pixels	1928 (H) x 1084(V)
Number of Active Pixels	1920 (H) x 1080 (V)
Pixel Size	7.4 μm (H) x 7.4 μm (V)
Active Image Size	14.208 mm (H) x 7.992 mm (V) 16.3 mm (diagonal)
Aspect Ratio	16:9
Number of Outputs	1 or 2
Saturation Signal	40,000 electrons
Output Sensitivity	14 μV/electron
Quantum Efficiency KAI-2093-ABA (490 nm)	40%
Quantum Efficiency KAI-2093-CBA R(620 nm), G(540nm), B(460nm)	37%, 34%, 30%
Total Noise	40 electrons rms
Dark Current (Typical)	<0.5 nA/cm ²
Dynamic Range	60 dB
Blooming Suppression	100 X
Smear	<0.03%
Image Lag	<10 electrons
Frame Rate	
Single Output, 20 MHz	9 fps
Single Output, 35 MHz	15 fps
Dual Outputs, 20 MHz	17 fps
Dual Outputs, 37 MHz	30 fps
Maximum Data Rate	40 MHz/Channel (2 channels)
Package	32 pin cerDIP
Cover Glass	Clear Glass or Quartz Glass with AR Coating, 2 sides

Parameters above are specified at T = 40 °C unless otherwise noted.



Ordering Information

	Product Name	Description	Marking Code
2H4736	KAI-2093-AAA-CP-AE	Monochrome, No Microlens, CERDIP Package (sidebrazed), Taped Clear Cover Glass (no coatings), Engineering Sample	KAI-2093 Serial Number
2H4617	KAI-2093-AAA-CP-BA	Monochrome, No Microlens, CERDIP Package (sidebrazed), Taped Clear Cover Glass (no coatings), Standard Grade	
2H4728	KAI-2093-ABA-CB-AE	Monochrome, Telecentric Microlens, CERDIP Package (sidebrazed), Clear Cover Glass (no coatings), Engineering Sample	KAI-2093M Serial Number
4H0174	KAI-2093-ABA-CB-B1	Monochrome, Telecentric Microlens, CERDIP Package (sidebrazed), Clear Cover Glass (no coatings), Grade 1	
2H4725	KAI-2093-ABA-CB-B2	Monochrome, Telecentric Microlens, CERDIP Package (sidebrazed), Clear Cover Glass (no coatings), Grade 2	
2H4923	KAI-2093-ABA-CK-AE	Monochrome, Telecentric Microlens, CERDIP Package (sidebrazed), Quartz Cover Glass with AR coating (both sides), Engineering Sample	
2H4920	KAI-2093-ABA-CK-BA	Monochrome, Telecentric Microlens, CERDIP Package (sidebrazed), Quartz Cover Glass with AR coating (both sides), Standard Grade	
2H4618	KAI-2093-ABA-CP-AE	Monochrome, Telecentric Microlens, CERDIP Package (sidebrazed), Taped Clear Cover Glass (no coatings), Engineering Sample	
2H4616	KAI-2093-ABA-CP-BA	Monochrome, Telecentric Microlens, CERDIP Package (sidebrazed), Taped Clear Cover Glass (no coatings), Standard Grade	
4H0137	KAI-2093-CBA-CB-AE	Color (Bayer RGB), Telecentric Microlens, CERDIP Package (sidebrazed), Clear Cover Glass (no coatings), Engineering Sample	KAI-2093CM Serial Number
4H0136	KAI-2093-CBA-CB-BA	Color (Bayer RGB), Telecentric Microlens, CERDIP Package (sidebrazed), Clear Cover Glass (no coatings), Standard Grade	
4H0705	KEK-4H0705-KAI-2093-10-40	Evaluation Board, 10 Bit, 40 MHz (Complete Kit)	n/a
4H0706	KEK-4H0706-KAI-2093-12-20	Evaluation Board, 12 Bit, 20 MHz (Complete Kit)	n/a

See Application Note *Product Naming Convention* for a full description of the naming convention used for image sensors. For reference documentation, including information on evaluation kits, please visit our web site at www.truesenseimaging.com.

Please address all inquiries and purchase orders to:

Truesense Imaging, Inc.
1964 Lake Avenue
Rochester, New York 14615

Phone: (585) 784-5500
E-mail: info@truesenseimaging.com

ON Semiconductor reserves the right to change any information contained herein without notice. All information furnished by ON Semiconductor is believed to be accurate.



Device Description

ARCHITECTURE



Figure 1: Sensor Architecture

There are 4 light shielded rows followed by 1084 photoactive rows and finally 4 more light shielded rows. The first and last 2 photoactive rows are buffer rows giving a total of 1080 lines of image data.

In the single output mode all pixels are clocked out of the Video L output in the lower left corner of the sensor. The first four empty pixels of each line do not receive charge from the vertical shift register. The next 28 pixels receive charge from the left light shielded edge followed by 1928 photoactive pixels and finally 28 more light shielded pixels from the right edge of the sensor. The first and last 4 photoactive pixels are buffer pixels giving a total of 1920 pixels of image data.

In the dual output mode the clocking of the right half of the horizontal CCD is reversed. The left half of the image is clocked out Video L and the right half of the image is clocked out Video R. Each row consists of 4 empty pixels followed by 28 light shielded pixels followed by 964 photoactive pixels. When reconstructing the image, data from Video R will have to be reversed in a line buffer and appended to the Video L data.



PIN DESCRIPTION AND PHYSICAL ORIENTATION



Figure 2: Package Pin Designations - Top View

Pin	Label
1	ϕ R
2	ϕ H2BL
3	ϕ H1BL
4	ϕ H1SL
5	ϕ H2SL
6	GND
7	OG
8	RD
9	RD
10	OG
11	GND
12	ϕ H2SR
13	ϕ H1SR
14	ϕ H1BR
15	ϕ H2BR
16	ϕ R

Pin	Label
17	VSS
18	VOUTR
19	GND
20	ϕ V2O
21	ϕ V1
22	VSUB
23	GND
24	VDDR
25	VDDL
26	GND
27	VSUB
28	ϕ V1
29	ϕ V2E
30	ESD
31	VOUTL
32	VSS

The horizontal shift register is on the side of the sensor parallel to the row of pins 1 through 16. In single output mode the pixel closest to pin 1 will be read out first through Video L, the pixel closest to pin 17 will be read out last. In dual output mode the pixel closest to pin 16 will be read out first through Video R.



Imaging Performance

TYPICAL OPERATIONAL CONDITIONS

Description	Condition
Temperature	40 °C
Integration Time	33 ms (40 MHz HCCD frequency, 30 fps frame rate)
Operation	Nominal voltages and timing
Image defects are excluded from performance tests.	

OPTICAL SPECIFICATIONS

Symbol	Description	Min	Nom	Max	Unit	Notes
QE_{max}	Peak Quantum Efficiency	33	36		%	1
λQE	Peak Quantum Efficiency Wavelength		490		nm	1
QE(540)	Quantum Efficiency at 540nm	31	33		%	1
θQE_h	Microlens Acceptance Angle (horizontal)	± 12	± 13		degrees	2
θQE_v	Microlens Acceptance Angle (vertical)	± 25	± 30		degrees	2
NL	Maximum Photoresponse Nonlinearity		2		%	3, 4
ΔG	Maximum Gain Difference Between Outputs		10		%	3, 4
ΔNL	Maximum Signal Error caused by Nonlinearity Differences		1		%	3, 4

Notes:

1. For monochrome sensors.
2. Value is the angular range of incident light for which the quantum efficiency is at least 50% of QE_{max} at a wavelength of λQE . Angles are measured with respect to the sensor surface normal in a plane parallel to the horizontal axis (θQE_h) or in a plane parallel to the vertical axis (θQE_v).
3. Value is over the range of 10% to 90% of photodiode saturation.
4. Value is for the sensor operated without binning.

CCD SPECIFICATIONS

Symbol	Description	Min	Nom	Max	Unit	Notes
VNe	Vertical CCD Charge Capacity	45	50		ke^-	
HNe	Horizontal CCD Charge Capacity		100		ke^-	
PNe	Photodiode Charge Capacity	35	40		ke^-	1
I_d	Dark Current		0.3	1.0	nA/cm^2	
Lag	Image Lag		< 10	50	e^-	2
Xab	Antiblooming factor	100	300			3, 4, 5, 6
Smr	Vertical Smear		-75	-72	dB	3, 4

Notes:

1. This value depends on the substrate voltage setting. Higher photodiode saturation charge capacities will lower the antiblooming specification. Substrate voltage will be specified with each part for nominal photodiode charge capacity.
2. This is the first field decay lag at 70% saturation. Measured by strobe illumination of the device at 70% of photodiode saturation, and then measuring the subsequent frame's average pixel output in the dark.
3. Measured with a spot size of 100 vertical pixels.
4. Measured with F/4 imaging optics and continuous green illumination centered at 550 nm.
5. A blooming condition is defined as when the spot size doubles in size.
6. Antiblooming factor is the light intensity which causes blooming divided by the light intensity which first saturates the photodiodes.



OUTPUT AMPLIFIER SPECIFICATIONS

Symbol	Description	Nominal	Unit	Notes
P_d	Power Dissipation	120	mW	1
F_{-3dB}	Bandwidth	140	MHz	1
C_L	Max Off-chip Load	10	pF	2
A_v	Gain	0.75		1
$\Delta V/\Delta N$	Sensitivity	14	$\mu V/e^-$	1

Notes:

1. For a 5 mA output load on each amplifier. Per amplifier.
2. With total output load capacitance of $C_L = 10$ pF between the outputs and AC ground.

GENERAL SPECIFICATIONS

Symbol	Description	Nominal	Unit	Notes
n_{e-T}	Total Noise	40	e^- rms	1
DR	Dynamic Range	60	dB	2

Notes:

1. Includes system electronics noise, dark pattern noise and dark current shot noise at 20 MHz.
2. Uses $20\text{LOG}(PNe/n_{e-T})$.



Typical Performance Curves

MONOCHROME QUANTUM EFFICIENCY

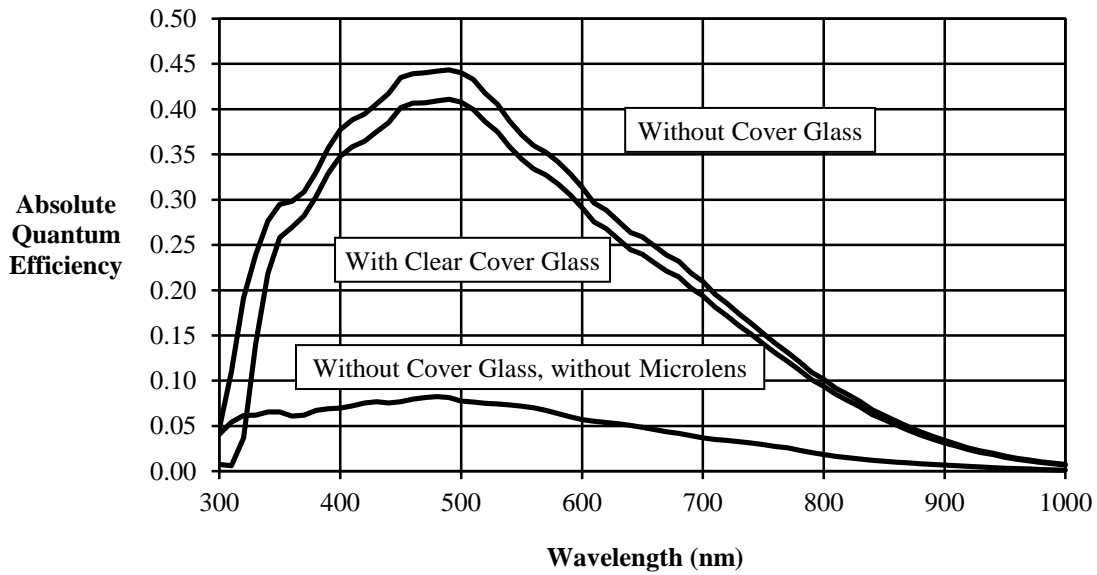

Figure 3: Quantum Efficiency Spectrum for Monochrome Sensors

MONOCHROME WITH MICROLENS ANGULAR QUANTUM EFFICIENCY

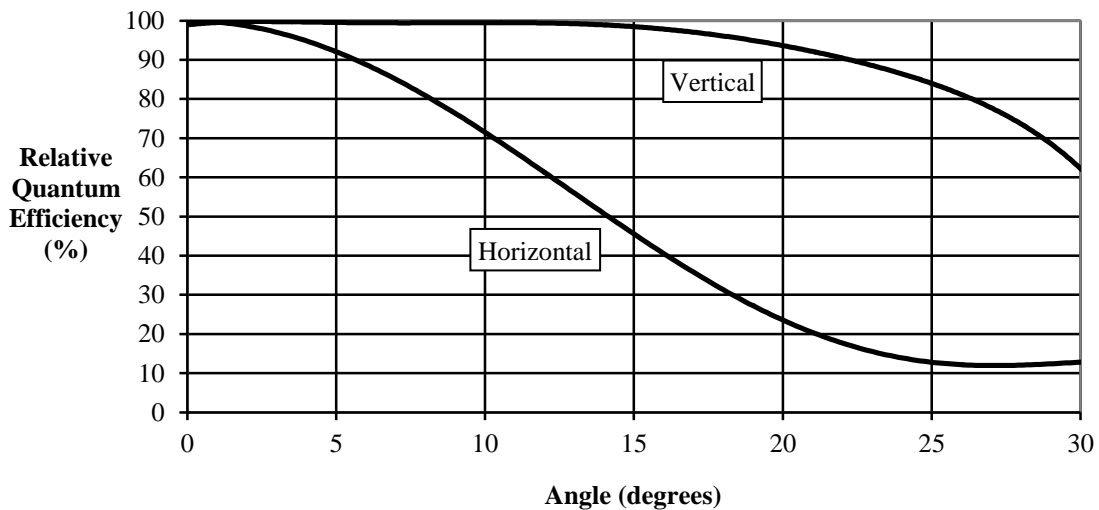

Figure 4: Angular Dependence of Quantum Efficiency

For the curve marked "Horizontal", the incident light angle is varied in a plane parallel to the HCCD.

For the curve marked "Vertical", the incident light angle is varied in a plane parallel to the VCCD.



COLOR WITH MICROLENS QUANTUM EFFICIENCY

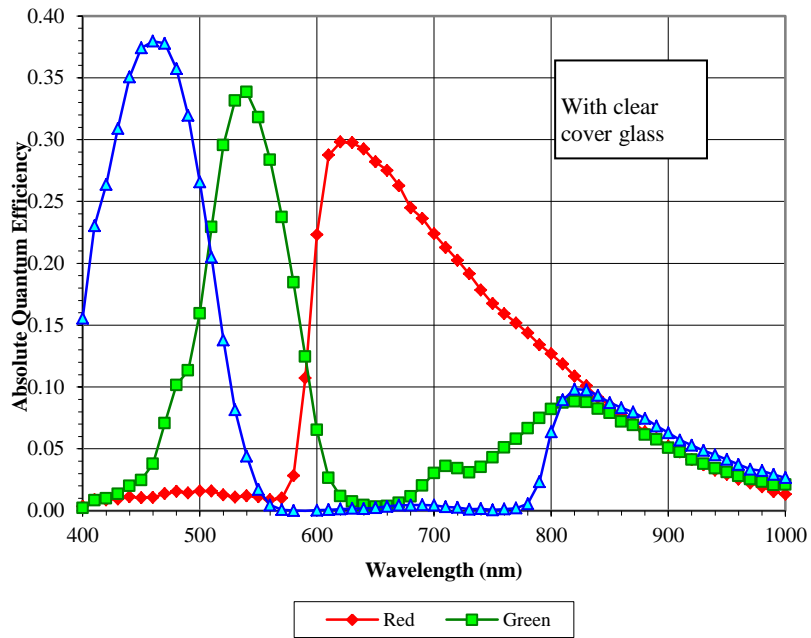

Figure 5: Quantum Efficiency Spectrum for Color Filter Array Sensors

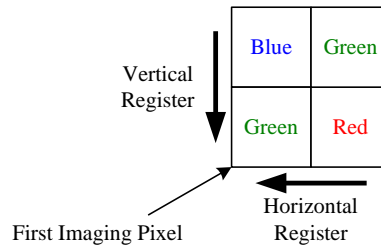

Figure 6: Color Filter Array Pattern



FRAME RATES



Figure 7: Progressive Frame Rate vs. HCCD Clock Frequency



Defect Definitions

OPERATIONAL CONDITIONS

Description	Condition
Temperature	40 °C
Integration Time	33 ms (40 MHz HCCD frequency, no binning, 30 fps frame rate)
Light source	Continuous green illumination centered at 550 nm
Operation	Nominal voltages and timing

SPECIFICATIONS

Name	Definition
Major Defective Pixel	A pixel whose signal deviates by more than 25 mV from the mean value of all active pixels under dark field condition or by more than 15% from the mean value of all active pixels under uniform illumination of 80% of saturation
Minor Defective Pixel	A pixel whose signal deviates by more than 8 mV from the mean value of all active pixels under dark field conditions
Cluster Defect	A group of 2 to 10 contiguous major defective pixels with a width no wider than 2 defective pixels
Column Defect	A group of more than 10 contiguous major defective pixels along a single column

Notes:

1. There will be at least two non-defective pixels separating any two major defective pixels.
2. Buffer and dark reference pixels are not used for defect tests.



DEFECT ZONES

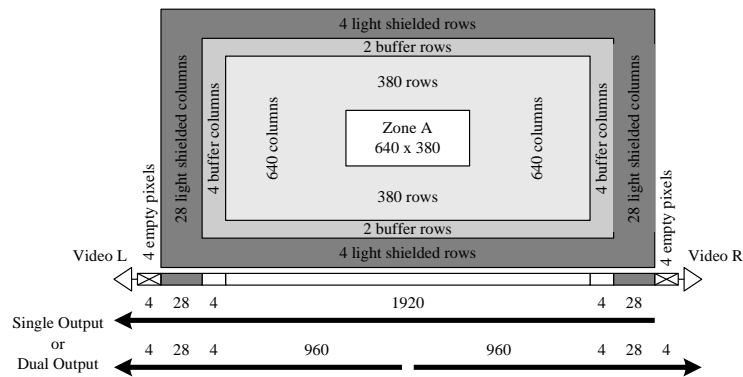

Figure 8: Defect Zones

DEFECT CLASSES

KAI-2093-ABA-CB-B1

Maximum Number of Defects							
Major Point		Minor Point		Cluster		Column	
Within Zone A	Outside Zone A	Within Zone A	Outside Zone A	Within Zone A	Outside Zone A	Within Zone A	Outside Zone A
3	10	20	100	0	4	0	0

All Other Part Numbers

Zone A is not used

Maximum Number of Defects			
Major Point	Minor Point	Cluster	Column
10	100	4	0



Operation

ABSOLUTE MAXIMUM RATINGS

		Min	Max	Unit	Notes
Temperature	Operation without damage	-50	70	°C	
Voltage between pins	VSUB to GND	8	20	V	1, 3
	VDD, OG to GND	0	17	V	
	VRD to GND	0	14	V	
	$\phi V1$ to $\phi V2$	-20	20	V	
	$\phi H1$ to $\phi H2$	-15	15	V	
	ϕR to GND	-15	15	V	
	$\phi H1, \phi H2$ to OG	-15	15	V	
	$\phi H1, \phi H2$ to $\phi V1, \phi V2$	-15	15	V	
Current	Video Output Bias Current	0	10	mA	2

Notes:

1. For electronic shuttering VSUB may be pulsed to 50 V for up to 10 μ s.
2. Total for both outputs. Current is 5 mA for each output. Note that the current bias affects the amplifier bandwidth.
3. Refer to Application Note *Using Interline CCD Image Sensors in High Intensity Visible Lighting Conditions*.

DC BIAS OPERATING CONDITIONS

Symbol	Description	Min	Nom	Max	Unit	Notes
OG	Output Gate	-3.0	-2.5	-2.0	V	
VRD	Reset Drain	10.0	10.5	11.0	V	
VSS	Output Amplifier Return	0.0	0.7	1.0	V	
VDD	Output Amplifier Supply	14.5	15.0	15.5	V	
GND	Ground, P-well		0.0		V	
VSUB	Substrate	8.0	TBD	17.0	V	2
VESD	ESD Protection	-8.0	-7.0	-6.0	V	1

Notes:

1. VESD must be at least 1 V more negative than $\phi H1L$ and $\phi H2L$ during sensor operation AND during camera power turn on.
2. Refer to Application Note *Using Interline CCD Image Sensors in High Intensity Visible Lighting Conditions*.



AC OPERATING CONDITIONS

Symbol	Description	Min	Nom	Max	Unit	Notes
$\phi V2H$	Vertical CCD Clock High	7.5	8.0	8.5	V	
$\phi V1M, \phi V2M$	Vertical CCD Clocks Midlevel	-1.6	-1.5	-1.4	V	
$\phi V1L, \phi V2L$	Vertical CCD Clocks Low	-9.5	-9.0	-8.5	V	
$\phi H1H, \phi H2H$	Horizontal CCD Clocks High	0.5	1.0	2.0	V	
$\phi H1L, \phi H2L$	Horizontal CCD Clocks Low	-5.0	-4.0	-3.8	V	
ϕR	Reset Clock Amplitude		5.0		V	
ϕRL	Reset Clock Low	-4.0	-3.5	-3.0	V	
VShutter	Electronic Shutter Voltage	44	48	52	V	1

Notes:

1. Refer to Application Note *Using Interline CCD Image Sensors in High Intensity Visible Lighting Conditions*.

The figure below shows the DC bias (V_{SUB}) and AC clock (V_{ES}) applied to the SUB pin. Both the DC bias and AC clock are referenced to ground.

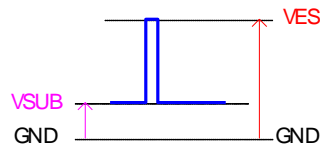

CLOCK CAPACITANCE

Clocks	Capacitance	Units	Notes
$\phi V1$ to GND	25	nF	1
$\phi V2$ to GND	25	nF	1
$\phi V1$ to $\phi V2$	5	nF	
$\phi H1S$ to GND	45	pF	2
$\phi H2S$ to GND	38	pF	2
$\phi H1B$ to GND	21	pF	2
$\phi H2B$ to GND	20	pF	2
$\phi H2B$ to $\phi H1S$	10	pF	2
$\phi H1B$ to $\phi H1S$	10	pF	2
$\phi H2B$ to $\phi H2S$	10	pF	2
$\phi H1B$ to $\phi H2S$	10	pF	2
ϕR to GND	10	pF	

Notes:

1. Gate capacitance to GND is voltage dependent. Value is for nominal VCCD clock voltages.
2. For nominal HCCD clock voltages, total capacitance for one half (H1SR only or H1SL only).



OPERATION NOTES

Progressive and Interlaced Timing

Progressive and interlaced output modes are achieved by the applying the proper waveforms to the vertical clock input pins $\phi V1$, $\phi V2E$ and $\phi V2O$. For progressive output, $\phi V2 = \phi V2E = \phi V2O$, with each of the 1092 lines read out individually using the timing in Figure 9.

For interlaced output, there are two modes, field integration mode and frame integration mode. In both modes, $1092/2 = 546$ lines are read in each frame readout, with one even frame readout and one odd frame readout necessary for a complete frame. Field integration mode bins together alternate lines, and the timing is shown in Figure 11. As with progressive readout, $\phi V2 = \phi V2E = \phi V2O$.

Frame integration mode reads out the photodiodes of the even and odd lines separately, and the timing is shown in Figure 12. In this case, $\phi V2E$ and $\phi V2O$ are clocked individually.

Single Output Mode

When operating the sensor in single output mode all pixels of the image sensor will be shifted out the Video L output (pin 31). To conserve power and lower heat generation the output amplifier for Video R may be turned off by connecting VDDR (pin 24) and VOUTR (pin 18) to GND (zero volts).

The $\phi H1$ timing from the timing diagrams should be applied to $\phi H1SL$, $\phi H1BL$, $\phi H1SR$, $\phi H2BR$, and the $\phi H2$ timing should be applied $\phi H2SL$, $\phi H2BL$, $\phi H2SR$, $\phi H1BR$. In other words, the clock driver generating the $\phi H1$ timing should be connected to pins 4, 3, 13, and 15. The clock driver generating the $\phi H2$ timing should be connected to pins 2, 5, 12, and 14.

The horizontal CCD should be clocked for 4 empty pixels plus 28 light shielded pixels plus 1928 photoactive pixels plus 28 light shielded pixels for a total of 1988 pixels.

DUAL OUTPUT MODE

In dual output mode the connections to the $\phi H1BR$ and $\phi H2BR$ pins are swapped from the single output mode to change the direction of charge transfer of the right side horizontal shift register. In dual output mode both VDDL and VDDR (pins 25, 24) should be connected to 15 V.

The $\phi H1$ timing from the timing diagrams should be applied to $\phi H1SL$, $\phi H1BL$, $\phi H1SR$, $\phi H1BR$, and the $\phi H2$ timing should be applied to $\phi H2SL$, $\phi H2BL$, $\phi H2SR$, $\phi H2BR$. The clock driver generating the $\phi H1$ timing should be connected to pins 4, 3, 13, and 14. The clock driver generating the $\phi H2$ timing should be connected to pins 2, 5, 12, and 15.

The horizontal CCD should be clocked for 4 empty pixels plus 28 light shielded pixels plus 964 photoactive pixels for a total of 996 pixels.

If the camera is to have the option of dual or single output mode, the clock driver signals sent to $\phi H1BR$ and $\phi H2BR$ may be swapped by using a relay. Another alternative is to have two extra clock drivers for $\phi H1BR$ and $\phi H2BR$ and invert the signals in the timing logic generator. If two extra clock drivers are used, care must be taken to ensure the rising and falling edges of the $\phi H1BR$ and $\phi H2BR$ clocks occur at the same time (within 3 ns) as the other HCCD clocks.



EXPOSURE CONTROL

If the sensor is operated at 20 MHz horizontal CCD frequency then the frame rate will be 9 fps and the integration time will be 1/9 s or 111 ms. To achieve shorter integration times, the electronic shutter option may be used by applying a pulse to the substrate (pins 22 and 27). The time between the falling edge of the substrate pulse and the falling edge of the transition of the $\phi V2$ clock from $\phi V2H$ to $\phi V2M$ is defined as the integration time. The substrate pulse and integration time are shown in Figure 14.

Integration times longer than one frame time (111 ms in this example) do not require use of the electronic shutter. Without the electronic shutter the integration time is defined as the time between when the $\phi V2$ clock is at the $\phi V2H$ level of 9.5 V (when the $\phi V2$ clock is at the $\phi V2H$ level charge collected in the photodiodes is transferred to the vertical shift register). To extend the integration time, increase the time between each $\phi V2H$ level of the $\phi V2$ clock. While the photodiodes are integrating photoelectrons the vertical and horizontal shift registers should be continuously clocked to prevent the collection of dark current in the vertical shift register. This is most easily done by increasing the number of lines read out of the image sensor. For example, to double the integration time read out 2184 lines instead of 1092 lines (but remember only the first 1092 lines will contain image data).

Depending on the image quality desired and temperature of the sensor, integration times longer than one second may require the sensor to be cooled to control dark current. The output amplifiers will also generate a non-uniform dark current pattern near the bottom corners of the sensor. This can be reduced at long integration times by only turning on VDD to each amplifier during image readout. If the vertical and horizontal shift registers are also stopped during integration time, the dark current in the shift registers should be flushed out completely before transferring charge from the photodiodes to the vertical shift register.

DARK REFERENCES

There are 28 light shielded columns at the left and right side of the image sensor. The first and last two light shielded columns should not be used as a dark reference due to some light leakage under the edges of the light shielding. Only the center 24 columns should be used for dark reference line clamping. There are 4 light shielded rows at the top and bottom of the image sensor. Only the center two light shielded rows should be used as a dark reference.

CONNECTIONS TO THE IMAGE SENSOR

The reset clock signal operates at the pixel frequency. The traces on the circuit board to the reset clock pins should be kept short and of equal length to ensure that the reset pulse arrives at each pin simultaneously. The circuit board traces to the horizontal clock pins should also be placed to ensure that the clock edges arrive at each pin simultaneously. If reset pulses and the horizontal clock edges are misaligned the noise performance of the sensor will be degraded and balancing the offset and gain of the two output amplifiers will be difficult.

The bias voltages on OG, RD, VSS and VDD should be well filtered with capacitors placed as close to the pins as possible. Noise on the video outputs will be most strongly affected by noise on VSS, VDD, GND, and VSUB. If the electronic shutter is not used then a filtering capacitor should also be placed on VSUB. If the electronic shutter is used, the VSUB voltage should be kept as clean and noise free as possible.

The voltage on VSS may be set by using the 0.6 to 0.7 volt drop across a diode. Place the diode from VSS to GND. To disable one of the output amplifiers connect VDD to GND, do not let VDD float.

The ESD voltage must reach its operating point before any of the horizontal clocks reach their low level. If any pin on the sensor comes within 1 V of the ESD pin the electrostatic damage protection circuit will become active and will not turn off until all voltages are powered down. Operating the sensor with the ESD protection circuit active may damage the sensor.



Timing

REQUIREMENTS AND CHARACTERISTICS

Symbol	Description	Min	Nom	Max	Unit	Notes
T _{HD}	HCCD Delay	1.3	1.5	10.0	μs	
T _{VCCD}	VCCD Transfer time	1.3	1.5		μs	
T _{V3rd}	Photodiode Transfer time	8.0	12.0	15.0	μs	
T _{3P}	VCCD Pedestal time	20.0	25.0	50.0	μs	
T _{3D}	VCCD Delay	15.0	20.0	100.0	μs	
T _R	Reset Pulse time	5.0	10.0		ns	
T _S	Shutter Pulse time	3.0	5.0	10.0	μs	
T _{SD}	Shutter Pulse delay	1.0	1.6	10.0	μs	
T _H	HCCD Clock Period	25.0	50.0	200.0	ns	
T _{VR}	VCCD rise/fall time	0.0	0.1	1.0	μs	
T _{VE}	Vertical Clock Edge Alignment	0.0		100.0	ns	



FRAME TIMING

Frame Timing – Progressive Scan

Progressive Frame Timing

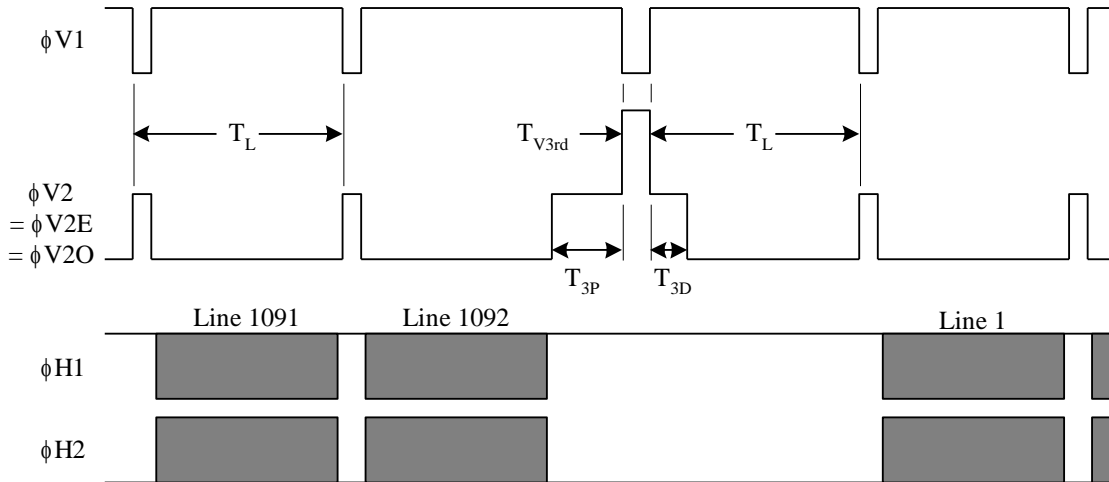

Frame Timing for Vertical Binning by 2

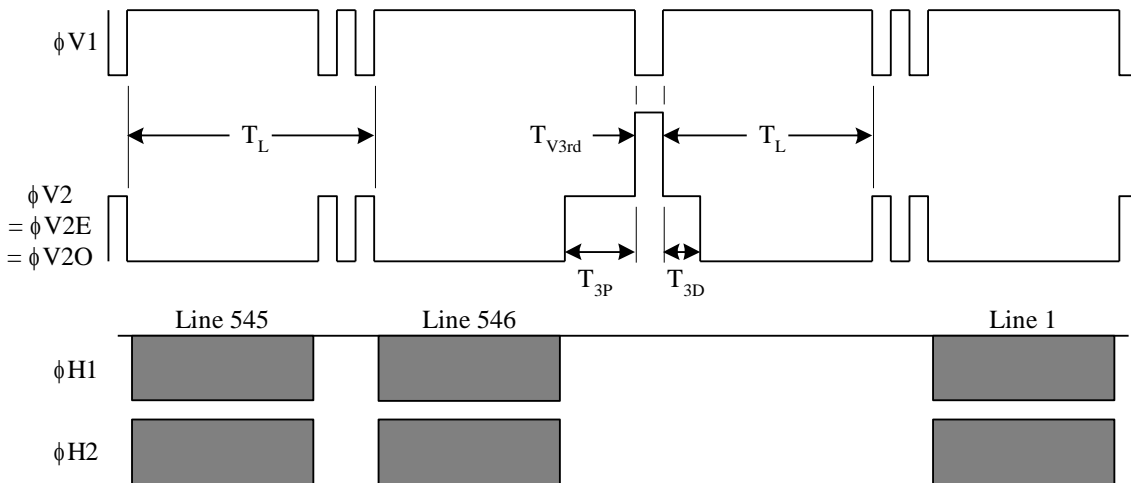

Figure 9: Progressive Frame Timing



VERTICAL CLOCK EDGE ALIGNMENT

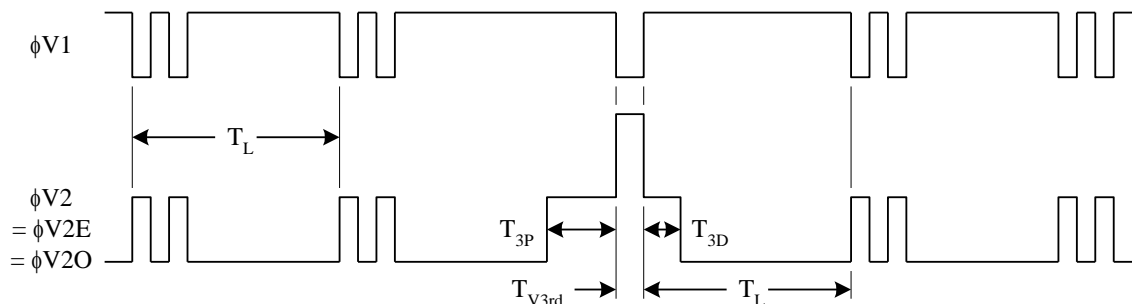

Figure 10: Ideal Vertical Clock Edge Position



FRAME TIMING – FIELD INTEGRATION MODE

Interlaced Frame Timing - Field Integration Mode - Even Field Readout



Interlaced Frame Timing - Field Integration Mode - Odd Field Readout

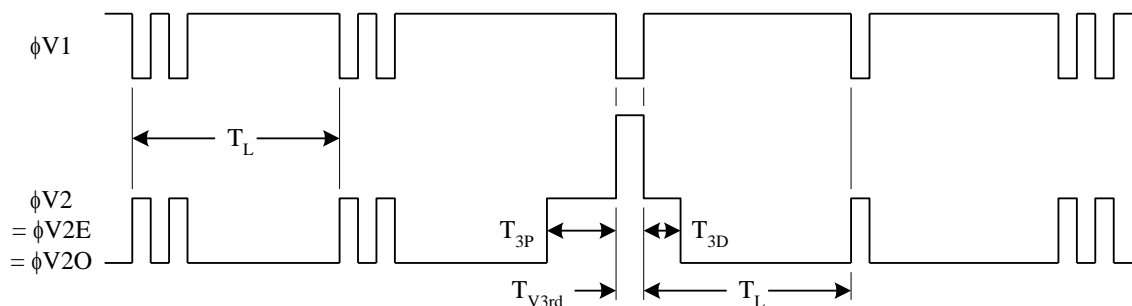
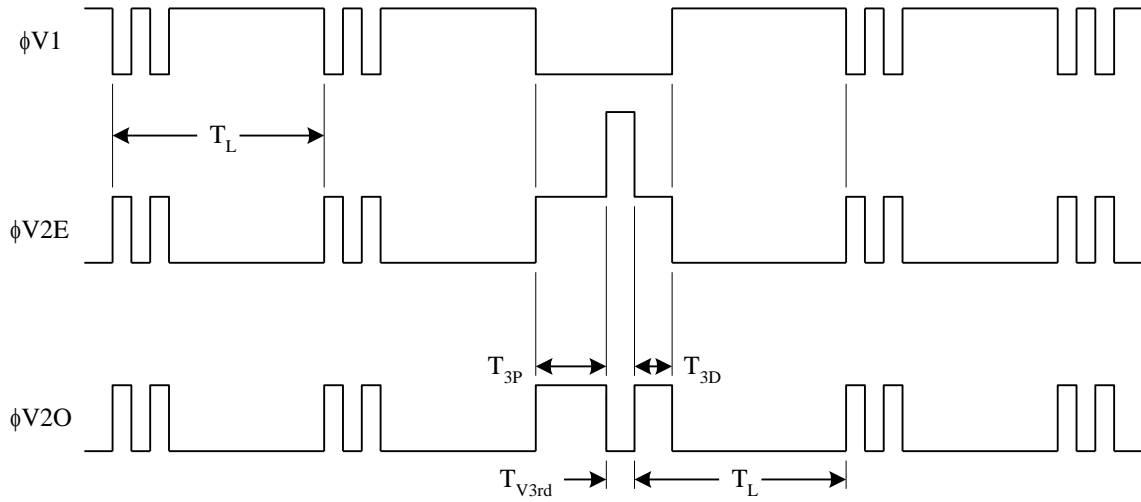

Figure 11: Interlaced Frame Timing - Field Integration Mode



FRAME TIMING – FRAME INTEGRATION MODE

Interlaced Frame Timing - Frame Integration Mode - Even Field Readout



Interlaced Frame Timing - Frame Integration Mode - Odd Field Readout

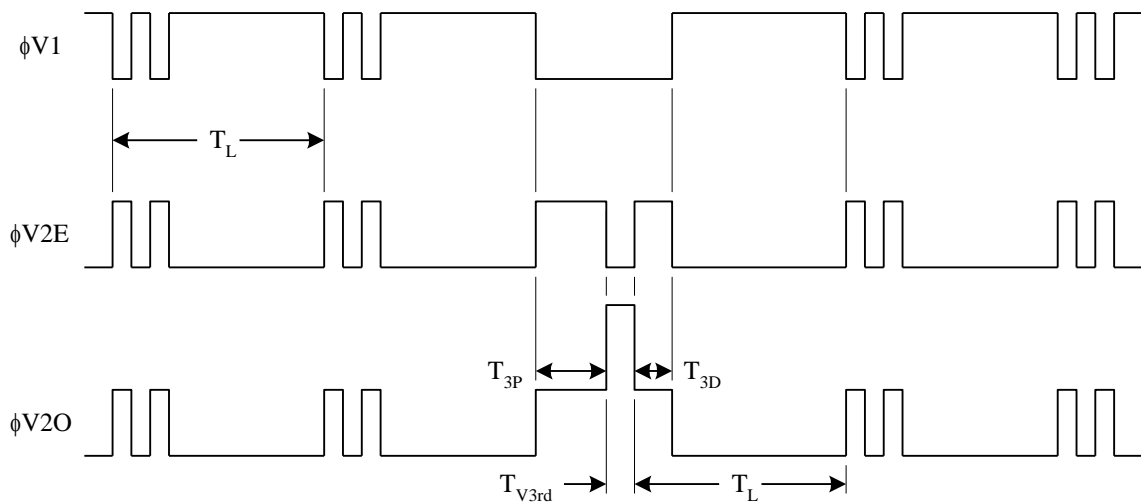

Figure 12: Interlaced Frame Timing - Frame Integration Mode



LINE TIMING

Progressive Line Timing



Interlaced Line Timing and Line Timing for Vertical Binning by Two

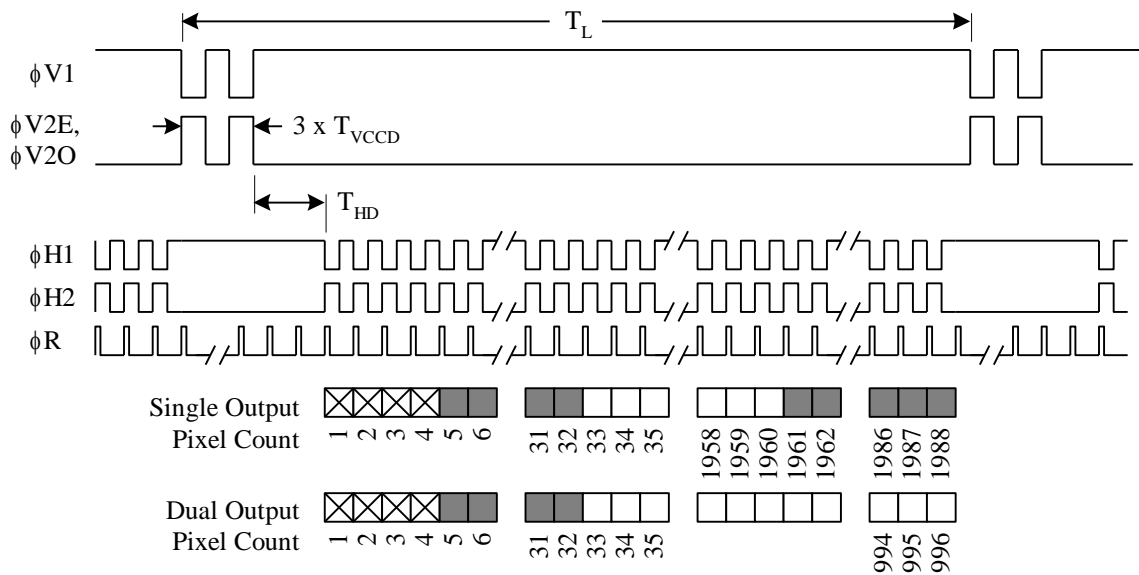
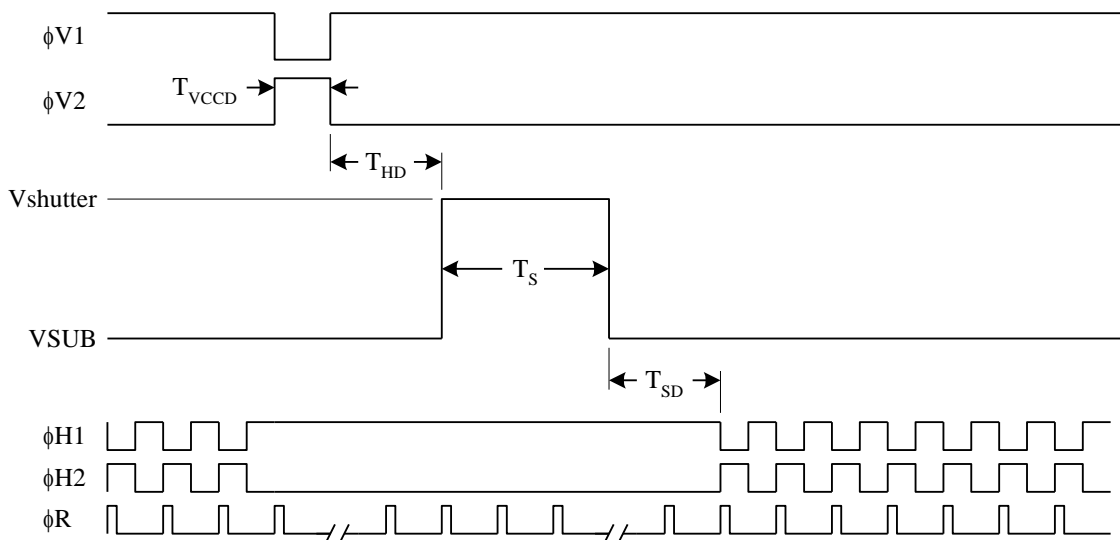

Figure 13: Line Timing



ELECTRONIC SHUTTER TIMING

Electronic Shutter Line Timing



Integration Time Definition

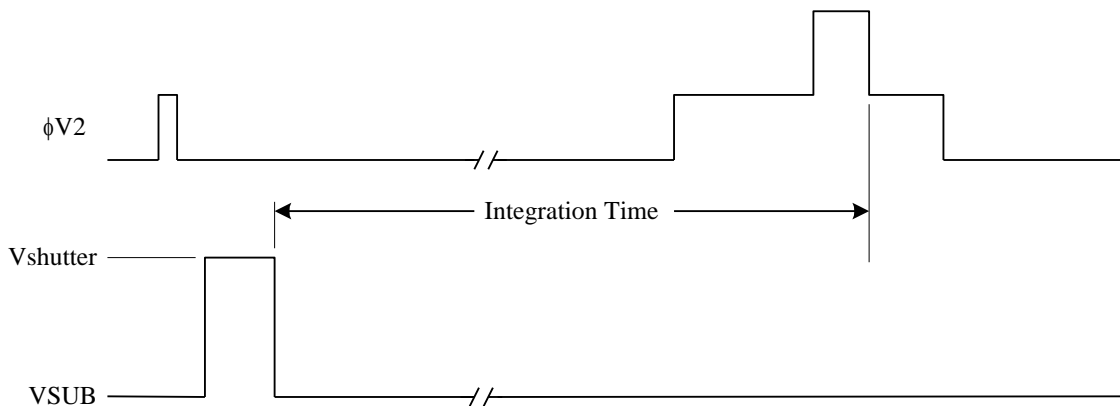

Figure 14: Electronic Shutter Timing Diagram



Storage and Handling

STORAGE CONDITIONS

Description	Symbol	Minimum	Maximum	Units	Notes
Temperature	T	-55	80	°C	1
Humidity	RH	5	90	%	2

Notes:

1. Long-term exposure toward the maximum temperature will accelerate color filter degradation.
2. T=25 °C. Excessive humidity will degrade MTTF.

ESD

1. This device contains limited protection against Electrostatic Discharge (ESD). ESD events may cause irreparable damage to a CCD image sensor either immediately or well after the ESD event occurred. Failure to protect the sensor from electrostatic discharge may affect device performance and reliability.
2. Devices should be handled in accordance with strict ESD procedures for Class 0 (<250V per JESD22 Human Body Model test), or Class A (<200V JESD22 Machine Model test) devices. Devices are shipped in static-safe containers and should only be handled at static-safe workstations.
3. See Application Note *Image Sensor Handling Best Practices* for proper handling and grounding procedures. This application note also contains workplace recommendations to minimize electrostatic discharge.
4. Store devices in containers made of electro-conductive materials.

COVER GLASS CARE AND CLEANLINESS

1. The cover glass is highly susceptible to particles and other contamination. Perform all assembly operations in a clean environment.
2. Touching the cover glass must be avoided.
3. Improper cleaning of the cover glass may damage these devices. Refer to Application Note *Image Sensor Handling Best Practices*.

ENVIRONMENTAL EXPOSURE

1. Extremely bright light can potentially harm CCD image sensors. Do not expose to strong sunlight for long periods of time, as the color filters and/or microlenses may become discolored. In addition, long time exposures to a static high contrast scene should be avoided. Localized changes in response may occur from color filter/microlens aging. For Interline devices, refer to Application Note *Using Interline CCD Image Sensors in High Intensity Visible lighting Conditions*.
2. Exposure to temperatures exceeding maximum specified levels should be avoided for storage and operation, as device performance and reliability may be affected.
3. Avoid sudden temperature changes.
4. Exposure to excessive humidity may affect device characteristics and may alter device performance and reliability, and therefore should be avoided.
5. Avoid storage of the product in the presence of dust or corrosive agents or gases, as deterioration of lead solderability may occur. It is advised that the solderability of the device leads be assessed after an extended period of storage, over one year.

SOLDERING RECOMMENDATIONS

1. The soldering iron tip temperature is not to exceed 370 °C. Higher temperatures may alter device performance and reliability.
2. Flow soldering method is not recommended. Solder dipping can cause damage to the glass and harm the imaging capability of the device. Recommended method is by partial heating using a grounded 30 W soldering iron. Heat each pin for less than 2 seconds duration.



Mechanical Drawings

COMPLETED ASSEMBLY



Figure 15: Completed Assembly (1 of 2)

Notes:

1. See Ordering Information for marking code.
2. Cover glass is manually placed and visually aligned over die – location accuracy is not guaranteed.

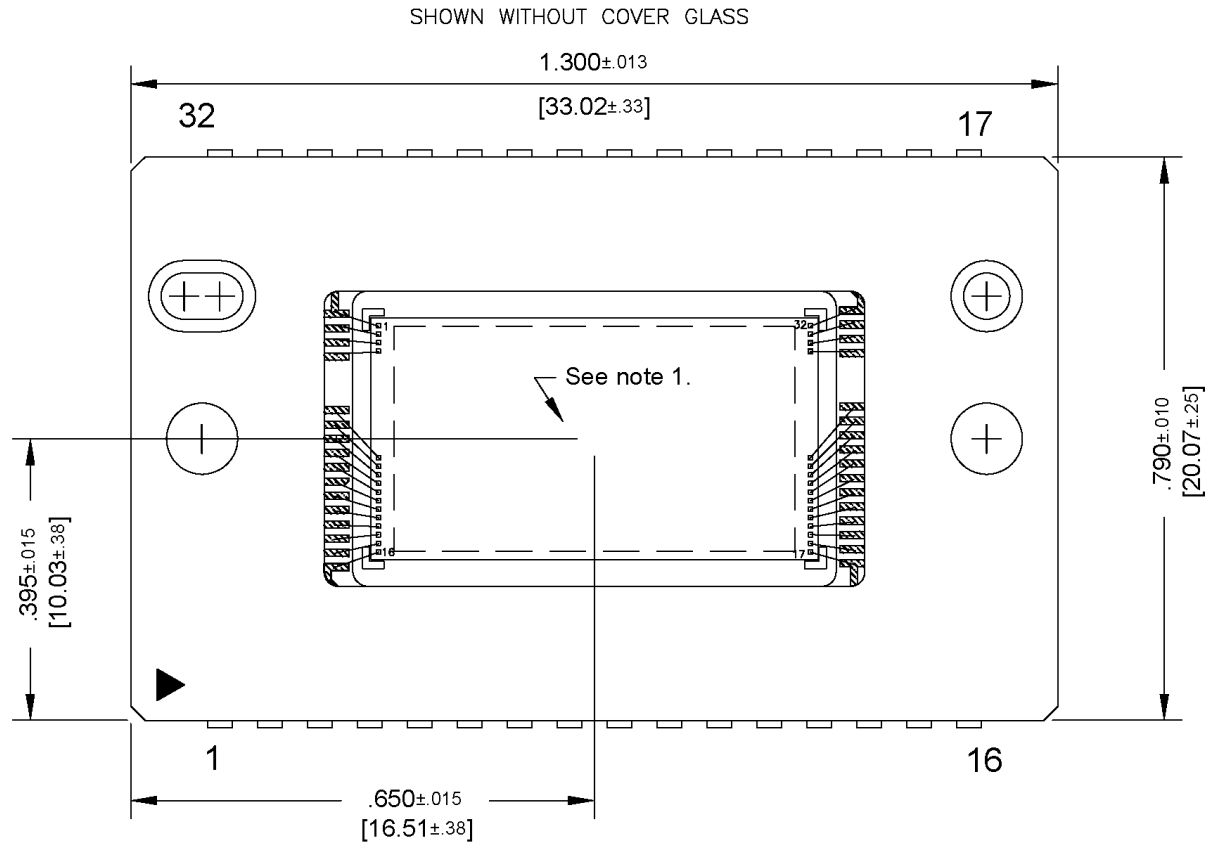

Figure 16: Completed Assembly (2 of 2)

Notes:

1. Center of image is nominally coincident with the center of the package.
2. Die is aligned within ± 2 degree of any package cavity edge.



COVER GLASS

Clear Cover Glass

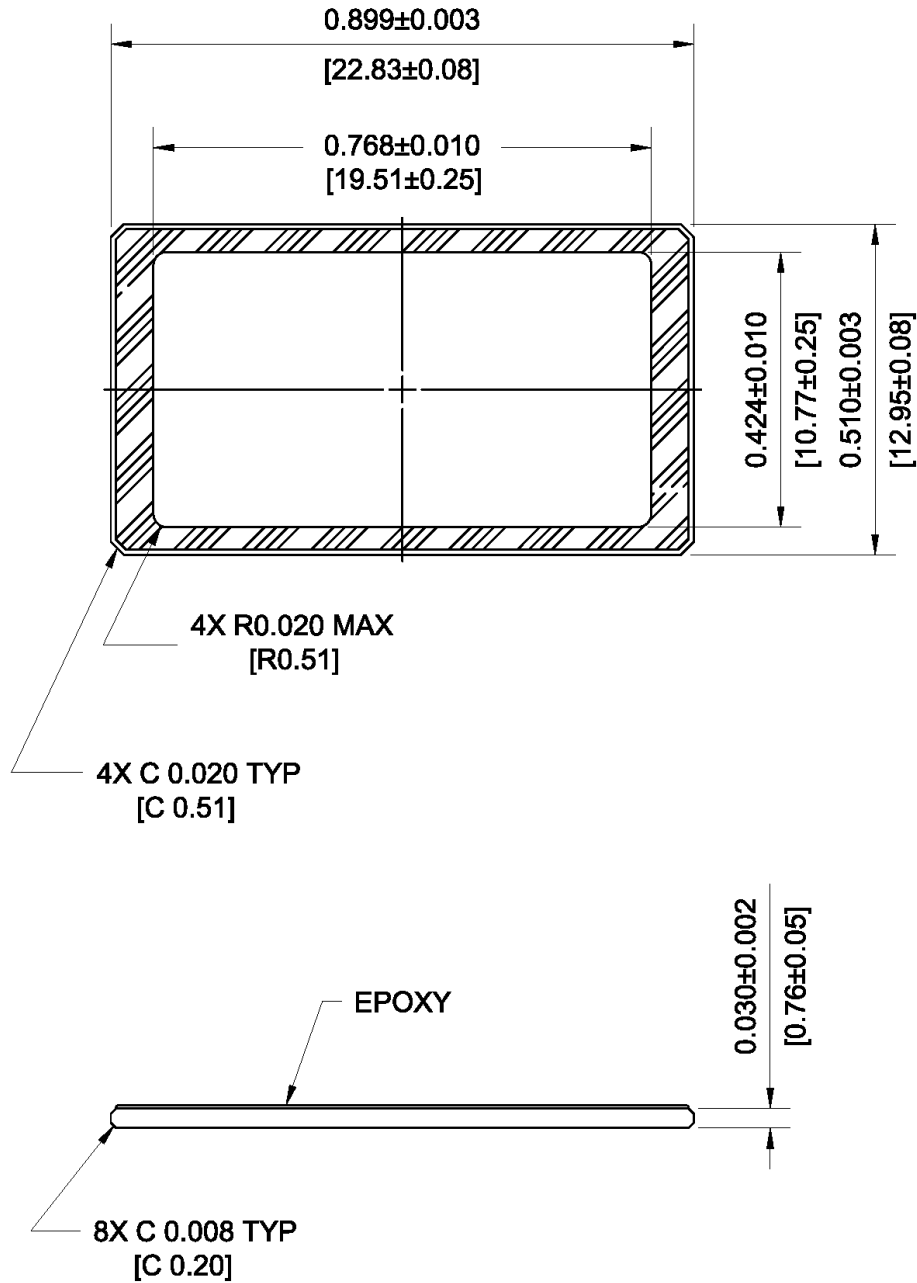

Figure 17: Clear Cover Glass Drawing

Notes:

1. Cover Glass Material: Schott D263T eco or equivalent.
2. Dust/Scratch: 5 microns maximum.



QUARTZ COVER GLASS WITH AR COATINGS

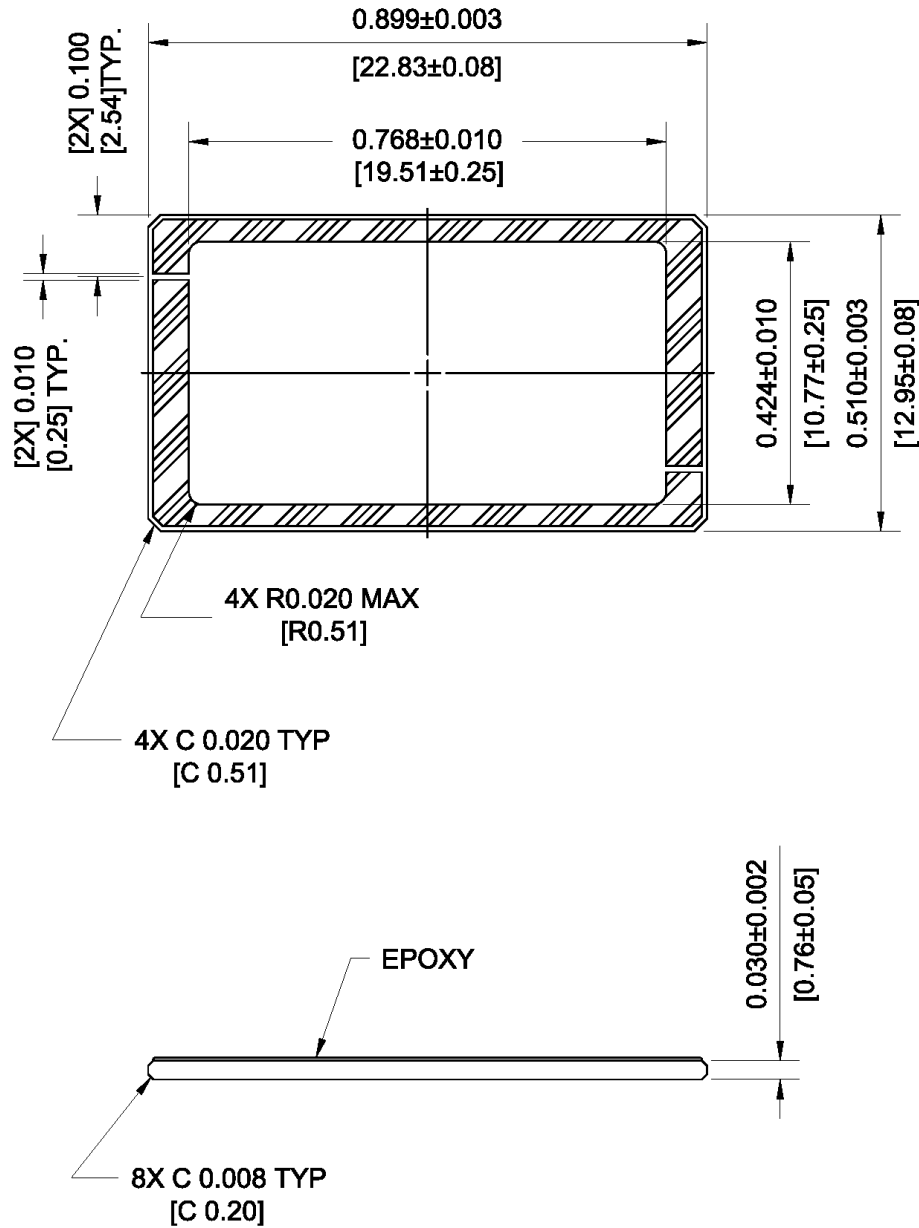

Figure 18: Quartz Cover Glass with AR Coating Drawing

Notes:

1. Cover Glass Material: SK1300 or equivalent.
2. Dust/Scratch: 10 microns maximum.
3. MAR Coat Each Side:
 340nm - 360nm: Reflectance ≤ 0.5%.
 520nm - 550nm: Reflectance ≤ 4%.



GLASS TRANSMISSION



Figure 19: Cover Glass Transmission



Quality Assurance and Reliability

QUALITY AND RELIABILITY

All image sensors conform to the specifications stated in this document. This is accomplished through a combination of statistical process control and visual inspection and electrical testing at key points of the manufacturing process, using industry standard methods. Information concerning the quality assurance and reliability testing procedures and results are available from ON Semiconductor upon request. For further information refer to Application Note *Quality and Reliability*.

REPLACEMENT

All devices are warranted against failure in accordance with the *Terms of Sale*. Devices that fail due to mechanical and electrical damage caused by the customer will not be replaced.

LIABILITY OF THE SUPPLIER

A reject is defined as an image sensor that does not meet all of the specifications in this document upon receipt by the customer. Product liability is limited to the cost of the defective item, as defined in the *Terms of Sale*.

LIABILITY OF THE CUSTOMER

Damage from mishandling (scratches or breakage), electrostatic discharge (ESD), or other electrical misuse of the device beyond the stated operating or storage limits, which occurred after receipt of the sensor by the customer, shall be the responsibility of the customer.

TEST DATA RETENTION

Image sensors shall have an identifying number traceable to a test data file. Test data shall be kept for a period of 2 years after date of delivery.

MECHANICAL

The device assembly drawing is provided as a reference.

ON Semiconductor reserves the right to change any information contained herein without notice. All information furnished by ON Semiconductor is believed to be accurate.

Life Support Applications Policy

ON Semiconductor image sensors are not authorized for and should not be used within Life Support Systems without the specific written consent of ON Semiconductor.



Revision Changes

MTD/PS-0307

Revision Number	Description of Changes
0.0	<ul style="list-style-type: none"> Initial Formal Version.
1.0	<ul style="list-style-type: none"> Page 8 section 3.5 AC Timing Conditions table: Added Tve: Vertical Clock Edge Alignment Page 10: Added Figure 5 Vertical Clock Timing – Edge Position Page 15: Updated Figure 9 Frame Rate to show dual mode out to 40 MHz. Previous plot cut off dual mode at 35 MHz Page 22: Added that a cluster defect will be no wider than two defective pixels. Page 22: Added a note that there will be at least two good pixels between any two major defects (pixels or clusters) Removed appendix 1 Added revision changes
2.0	<ul style="list-style-type: none"> Section 4.2, new color quantum efficiency
3.0	<ul style="list-style-type: none"> Updated format Updated defect definitions section Added Storage and Handling section Updated completed assembly drawing Added cover glass drawings Added cover glass transmission curves
3.1	<ul style="list-style-type: none"> Changed cover glass material to D263T eco or equivalent Updated Storage and Handling page references to Application Note <i>Image Sensor Handling and Best Practices</i>
4.0	<ul style="list-style-type: none"> Added the note "Refer to Application Note <i>Using Interline CCD Image Sensors in High Intensity Visible Lighting Conditions</i>" to the following sections <ul style="list-style-type: none"> Absolute Maximum Ratings DC Bias Operating Conditions AC Operating Conditions Storage and Handling

PS-0026

Revision Number	Description of Changes
1.0	<ul style="list-style-type: none"> Initial release with new document number, updated branding and document template Updated <i>Storage and Handling</i> and <i>Quality Assurance and Reliability</i> sections
1.1	<ul style="list-style-type: none"> Updated branding

ON Semiconductor and are registered trademarks of Semiconductor Components Industries, LLC (SCILLC). SCILLC owns the rights to a number of patents, trademarks, copyrights, trade secrets, and other intellectual property. A listing of SCILLC's product/patent coverage may be accessed at www.onsemi.com/site/pdf/Patent-Marking.pdf. SCILLC reserves the right to make changes without further notice to any products herein. SCILLC makes no warranty, representation or guarantee regarding the suitability of its products for any particular purpose, nor does SCILLC assume any liability arising out of the application or use of any product or circuit, and specifically disclaims any and all liability, including without limitation special, consequential or incidental damages. "Typical" parameters which may be provided in SCILLC data sheets and/or specifications can and do vary in different applications and actual performance may vary over time. All operating parameters, including "Typicals" must be validated for each customer application by customer's technical experts. SCILLC does not convey any license under its patent rights nor the rights of others. SCILLC products are not designed, intended, or authorized for use as components in systems intended for surgical implant into the body, or other applications intended to support or sustain life, or for any other application in which the failure of the SCILLC product could create a situation where personal injury or death may occur. Should Buyer purchase or use SCILLC products for any such unintended or unauthorized application, Buyer shall indemnify and hold SCILLC and its officers, employees, subsidiaries, affiliates, and distributors harmless against all claims, costs, damages, and expenses, and reasonable attorney fees arising out of, directly or indirectly, any claim of personal injury or death associated with such unintended or unauthorized use, even if such claim alleges that SCILLC was negligent regarding the design or manufacture of the part. SCILLC is an Equal Opportunity/Affirmative Action Employer. This literature is subject to all applicable copyright laws and is not for resale in any manner.

PUBLICATION ORDERING INFORMATION

LITERATURE FULFILLMENT:

Literature Distribution Center for ON Semiconductor
 P.O. Box 5163, Denver, Colorado 80217 USA
Phone: 303-675-2175 or 800-344-3860 Toll Free USA/Canada
Fax: 303-675-2176 or 800-344-3867 Toll Free USA/Canada
Email: orderlit@onsemi.com

N. American Technical Support: 800-282-9855 Toll Free
 USA/Canada
Europe, Middle East and Africa Technical Support:
 Phone: 421 33 790 2910
Japan Customer Focus Center
 Phone: 81-3-5817-1050

ON Semiconductor Website: www.onsemi.com

Order Literature: <http://www.onsemi.com/orderlit>

For additional information, please contact your local Sales Representative

Компания «Life Electronics» занимается поставками электронных компонентов импортного и отечественного производства от производителей и со складов крупных дистрибьюторов Европы, Америки и Азии.

С конца 2013 года компания активно расширяет линейку поставок компонентов по направлению коаксиальный кабель, кварцевые генераторы и конденсаторы (керамические, пленочные, электролитические), за счёт заключения дистрибьюторских договоров

Мы предлагаем:

- Конкурентоспособные цены и скидки постоянным клиентам.
- Специальные условия для постоянных клиентов.
- Подбор аналогов.
- Поставку компонентов в любых объемах, удовлетворяющих вашим потребностям.
- Приемлемые сроки поставки, возможна ускоренная поставка.
- Доставку товара в любую точку России и стран СНГ.
- Комплексную поставку.
- Работу по проектам и поставку образцов.
- Формирование склада под заказчика.
- Сертификаты соответствия на поставляемую продукцию (по желанию клиента).
- Тестирование поставляемой продукции.
- Поставку компонентов, требующих военную и космическую приемку.
- Входной контроль качества.
- Наличие сертификата ISO.

В составе нашей компании организован Конструкторский отдел, призванный помогать разработчикам, и инженерам.

Конструкторский отдел помогает осуществить:

- Регистрацию проекта у производителя компонентов.
- Техническую поддержку проекта.
- Защиту от снятия компонента с производства.
- Оценку стоимости проекта по компонентам.
- Изготовление тестовой платы монтаж и пусконаладочные работы.



Тел: +7 (812) 336 43 04 (многоканальный)

Email: org@lifeelectronics.ru