

16-BIT SERIAL TO PARALLEL CONVERTER

■ GENERAL DESCRIPTION

The **NJU3716A** is a 16-bit serial to parallel converter especially applying to MPU output expander. It can operate from 2.4V to 5.5V.

The effective output assignment of MPU is available as the connection between **NJU3716A** and MPU using only 4 lines.

The serial data synchronizing with 5MHz or more clock can be input to the serial data input terminal and the data are output from parallel output buffer through serial in parallel out shift register and parallel data latches.

Furthermore, the **NJU3716A** outputs the serial data from SO terminal through the shift register. Therefore, it connects with other SIPO ICs like as NJU3711A in cascade for expanding the parallel conversion outputs.

The hysteresis input circuit realizes wide noise margin and the high drive-ability output buffer (25mA) can drive LED directly.

■ PACKAGE OUTLINE



NJU3716AVC2

■ FEATURES

- 16-Bit Serial In Parallel Out
- Cascade Connection
- Hysteresis Input 0.5V typ at 5V
- Operating Voltage 2.4 to 5.5V
- Maximum Operating Frequency 5MHz
- Output Current 25mA at 5V, 5mA at 3V
- C-MOS Technology
- Package Outline SSOP24-C2

■ PIN CONFIGURATION

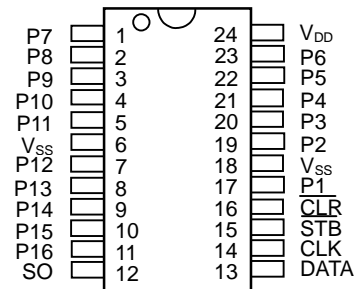

NJU3716AVC2

■ BLOCK DIAGRAM

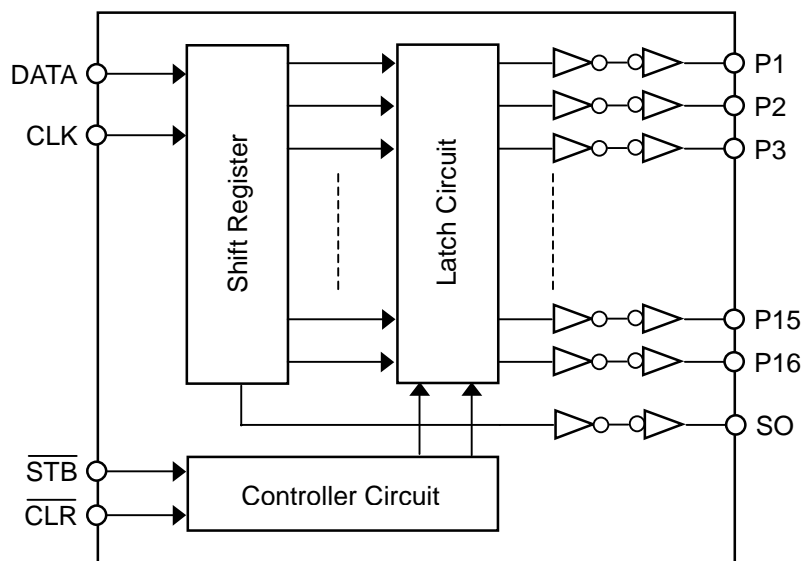

■ TERMINAL DESCRIPTION

No.	SYMBOL	I/O	FUNCTION
1	P7	O	Parallel Conversion Data Output Terminals
2	P8	O	
3	P9	O	
4	P10	O	
5	P11	O	
6	V _{SS}	-	GND
7	P12	O	Parallel Conversion Data Output Terminals
8	P13	O	
9	P14	O	
10	P15	O	
11	P16	O	
12	SO	O	Serial Data Output Terminal
13	DATA	I	Serial Data Input Terminal
14	CLK	I	Clock Signal Input Terminal
15	STB	I	Strobe Signal Input Terminal
16	CLR	I	Clear Signal Input Terminal
17	P1	O	Parallel Conversion Data Output Terminal
18	V _{SS}	-	GND
19	P2	O	Parallel Conversion Data Output Terminals
20	P3	O	
21	P4	O	
22	P5	O	
23	P6	O	
24	V _{DD}	-	Power Supply Terminal (2.4 to 5.5V)

■ FUNCTIONAL DESCRIPTION

(1) Reset

When the "L" level is input to the $\overline{\text{CLR}}$ terminal, all latches are reset and all of parallel conversion output are "L" level.

Normally, the $\overline{\text{CLR}}$ terminal should be "H" level.

(2) Data Transmission

In the $\overline{\text{STB}}$ terminal is "H" level and the clock signals are inputted to the CLK terminal, the serial data into the DATA terminal are shifted in the shift register synchronizing at a rising edge of the clock signal.



When the $\overline{\text{STB}}$ terminal is changed to "L" level, the data in the shift register are transferred to the latches.

Even if the $\overline{\text{STB}}$ terminal is "L" level, the input clock signal shifts the data in the shift register, therefore, the clock signal should be controlled for data order.

(3) Cascade Connection

The serial data input from DATA terminal is output from the SO terminal through internal shift register unrelated with the $\overline{\text{CLR}}$ and $\overline{\text{STB}}$ status.

Furthermore, the 4 input circuits provide a hysteresis characteristics using the schmitt trigger structure to protect the noise.

CLK	$\overline{\text{STB}}$	$\overline{\text{CLR}}$	OPERATION
X	X	L	All of latches are reset (the data in the shift register is no change). All of parallel conversion outputs are "L".
	H	H	The serial data into the DATA terminal are inputted to the shift register. In this stage, the data in the latch is not changed.
L	L	H	The data in the shift register is transferred to the latch. And the data in the latch is output from the parallel conversion output terminals.
H			
			
			When the clock signal is inputted into the CLK terminal in state of the $\overline{\text{STB}}="L"$ and $\overline{\text{CLR}}="H"$, the data is shifted in the shift register and latched data is also changed in accordance with the shift register.

Note 1) X: Don't care

■ TIMING CHART

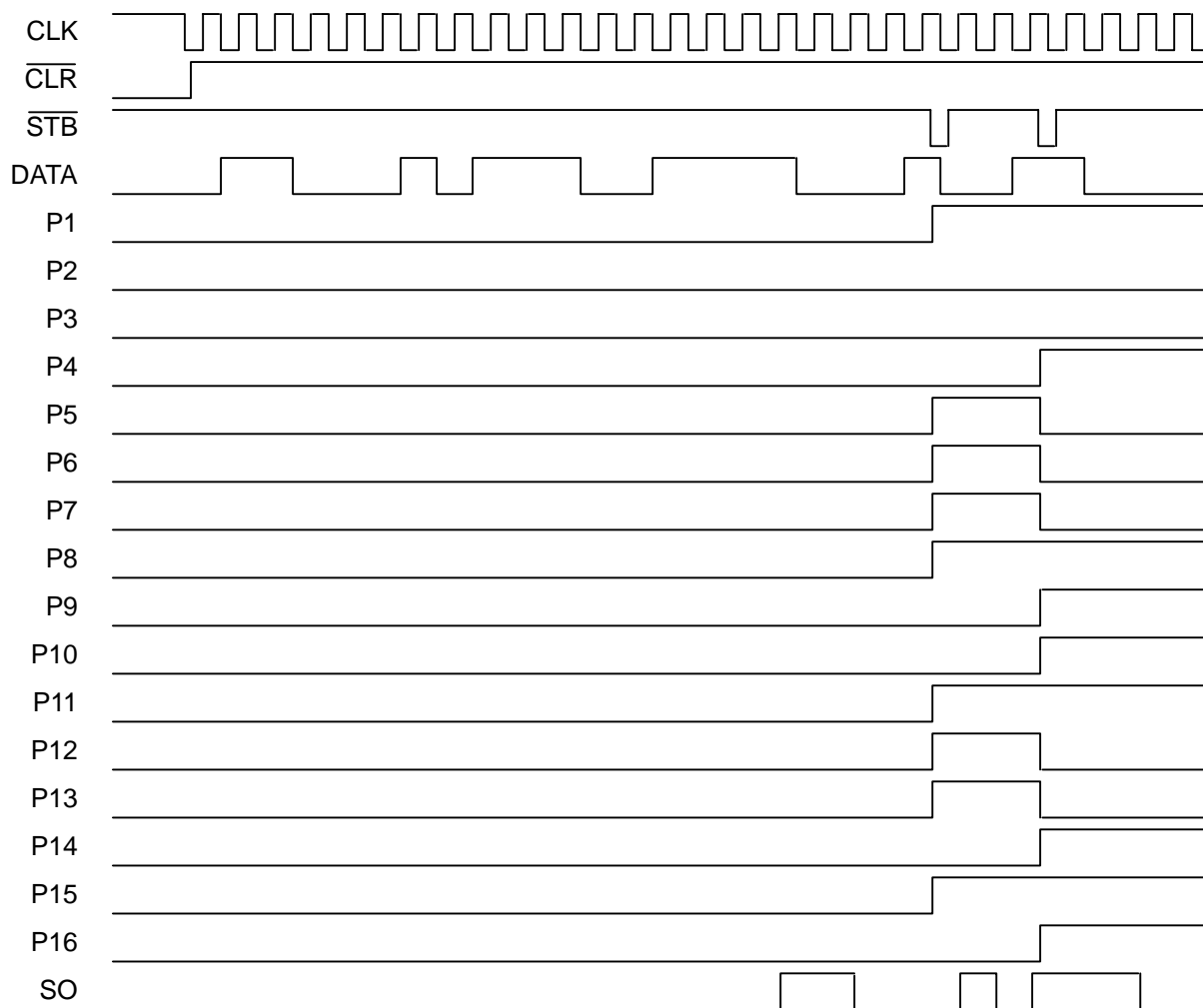

■ ABSOLUTE MAXIMUM RATINGS

(Ta=25°C)

PARAMETER	SYMBOL	RATINGS		UNIT
Supply Voltage Range	V_{DD}	-0.5 ~ +7.0		V
Input Voltage Range	V_I	$V_{SS}-0.5 \sim V_{DD}+0.5$		V
Output Voltage Range	V_O	$V_{SS}-0.5 \sim V_{DD}+0.5$		V
Output Current	I_O	±25		mA
Output Short Current (SO Terminal) (Note 5)	I_{OS}	$V_O=7V, V_I=0V$	10 (max)	mA
		$V_O=0V, V_I=7V$	-10 (max)	
Output Short Current (P1~P16 Terminals) (Note 5)	I_{OSD}	$V_O=7V, V_I=0V$	20 (max)	mA
		$V_O=0V, V_I=7V$	-20 (max)	
Power Dissipation	P_D	705 (SSOP) (Note 6)		mW
Operating Temperature Range	T_{opr}	-25 ~ +85		°C
Storage Temperature Range	T_{stg}	-65 ~ +150		°C

Note 2) All voltage are relative to $V_{SS}=0V$ reference.

Note 3) Do not exceed the absolute maximum ratings, otherwise the stress may cause a permanent damage to the IC. It is also recommended that the IC be used in the range specified in the DC electrical characteristics, or the electrical stress may cause malfunctions and impact on the reliability.

Note 4) To stabilize the IC operation, place decoupling capacitor between V_{DD} and V_{SS} .

Note 5) $V_{DD}=7V, V_{SS}=0V$, less than 1 second per pin.

Note 6) EIA/JEDEC Standard Test Board (76.2 x 114.3 x 1.6mm, 2layers, FR-4) mounting.

■ DC ELECTRICAL CHARACTERISTICS

($V_{DD}=2.4\sim 5.5V, V_{SS}=0V, T_a=25^\circ C$, unless otherwise noted)

PARAMETER	SYMBOL	CONDITION		MIN	TYP	MAX	UNIT	
Operating Voltage	V_{DD}			2.4	-	5.5	V	
Operating Current	I_{DDs}	$V_{IH}=V_{DD}, V_{IL}=V_{SS}$		-	-	0.1	mA	
High-level Output Voltage	V_{OH}	$I_{OH}=-0.4mA$	SO Terminal	$V_{DD}-0.4$	-	V_{DD}	V	
Low-level Output Voltage	V_{OL}	$I_{OL}=+3.2mA$		V_{SS}	-	0.4	V	
High-level Input Voltage	V_{IH}			$0.7V_{DD}$	-	V_{DD}	V	
Low-level Input Voltage	V_{IL}			V_{SS}	-	$0.3V_{DD}$	V	
Input Leakage Current	I_{LI}	$V_I=0\sim V_{DD}$		-10	-	10	μA	
High-level Output Voltage (Note 7)	V_{OHD}	$V_{DD}=5V$	$I_{OH}=-25mA$	P1~P16 Terminals	$V_{DD}-1.5$	-	V_{DD}	V
			$I_{OH}=-15mA$		$V_{DD}-1.0$	-	V_{DD}	
			$I_{OH}=-10mA$		$V_{DD}-0.5$	-	V_{DD}	
		$V_{DD}=3V$	$I_{OH}=-5mA$		$V_{DD}-0.5$	-	V_{DD}	
Low-level Output Voltage (Note 7)	V_{OLD}	$V_{DD}=5V$	$I_{OL}=+25mA$	P1~P16 Terminals	V_{SS}	-	1.5	V
			$I_{OL}=+15mA$		V_{SS}	-	0.8	
			$I_{OL}=+10mA$		V_{SS}	-	0.4	
		$V_{DD}=3V$	$I_{OL}=+5mA$		V_{SS}	-	0.5	

Note 7) Specified value represent output current per pin. When use, total current consideration and less than power dissipation in rating operation should be required.

NJU3716A

■ SWITCHING CHARACTERISTICS

($V_{DD}=2.4\sim 5.5V$, $V_{SS}=0V$, $T_a=25^\circ C$, unless otherwise noted)

PARAMETER	SYMBOL	CONDITION	MIN	TYP	MAX	UNIT
Set-Up Time	t_{SD}	DATA-CLK	20	-	-	ns
Hold Time	t_{HD}	CLK-DATA	20	-	-	ns
Set-Up Time	t_{SSTB}	\overline{STB} -CLK	30	-	-	ns
Hold Time	t_{HSTB}	CLK- \overline{STB}	30	-	-	ns
Output Delay Time	t_{pdO}	CLK-SO	-	-	70	ns
	t_{pdPCK}	CLK-P1~P16	-	-	100	ns
	t_{pdPSTB}	\overline{STB} -P1~P16	-	-	80	ns
	t_{pdPCLR}	\overline{CLR} -P1~P16	-	-	80	ns
Maximum Operating Frequency	f_{MAX}		5	-	-	MHz

Note 8) $C_{OUT}=50pF$

SWITCHING CHARACTERISTICS TEST WAVEFORM

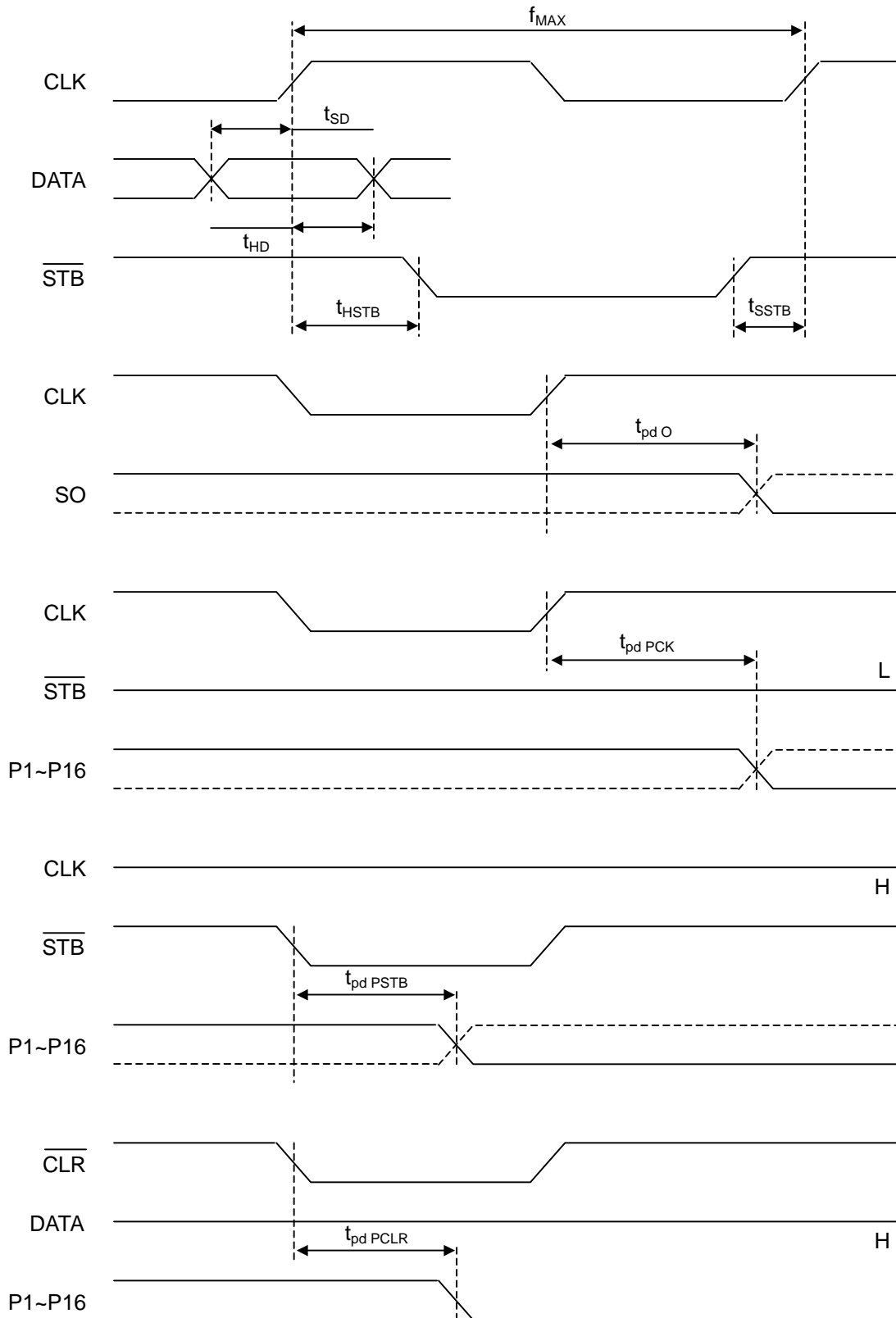

NJU3716A

■ APPLICATION CIRCUIT (1)

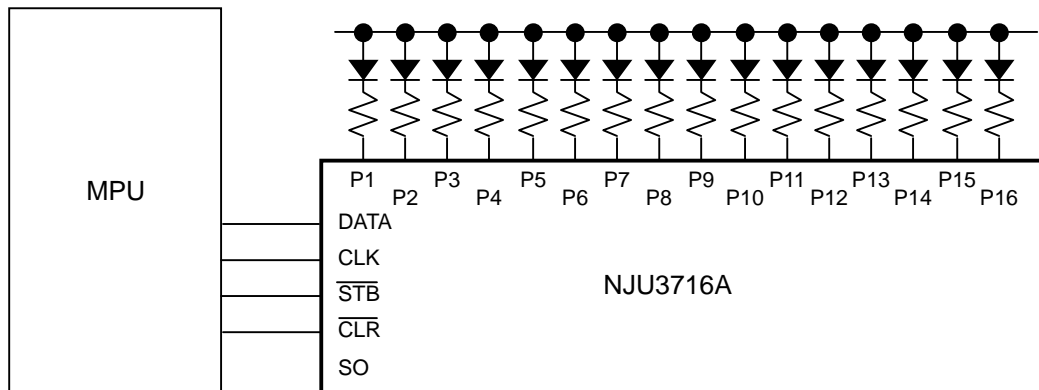

■ APPLICATION CIRCUIT (2) (Combined with NJU3711A)

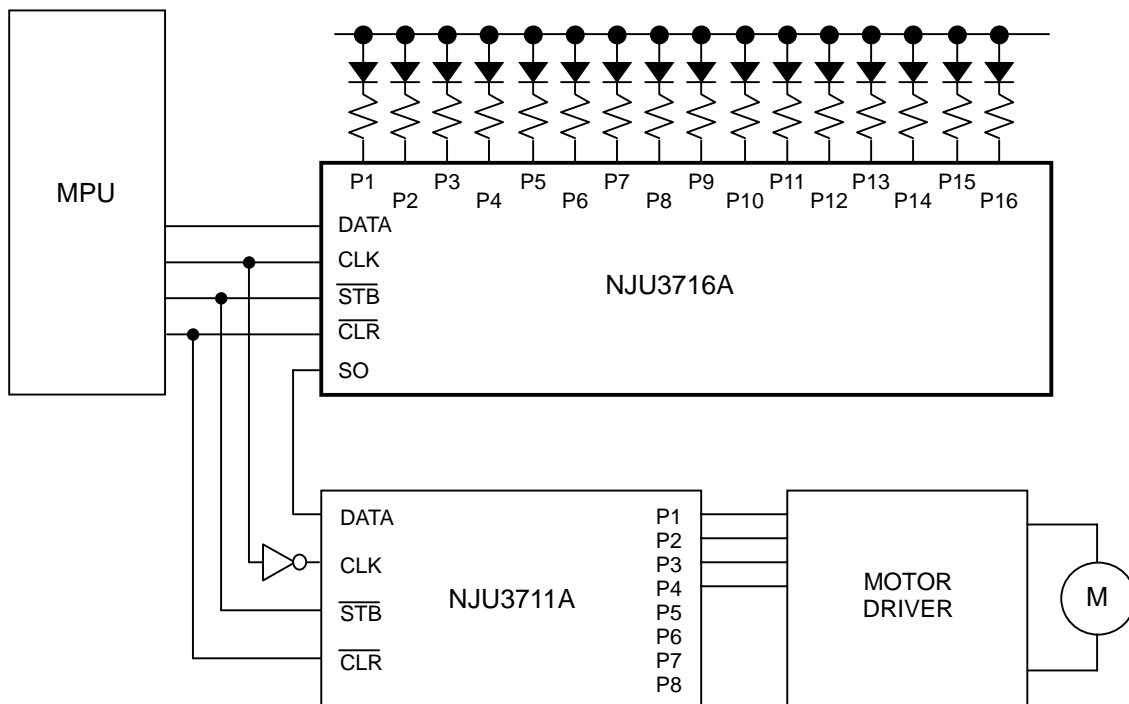

[CAUTION]
 The specifications on this databook are only given for information, without any guarantee as regards either mistakes or omissions. The application circuits in this databook are described only to show representative usages of the product and not intended for the guarantee or permission of any right including the industrial rights.

Mouser Electronics

Authorized Distributor

Click to View Pricing, Inventory, Delivery & Lifecycle Information:

[NJR:](#)

[NJU3716AVC2-TE1](#)

Компания «Life Electronics» занимается поставками электронных компонентов импортного и отечественного производства от производителей и со складов крупных дистрибьюторов Европы, Америки и Азии.

С конца 2013 года компания активно расширяет линейку поставок компонентов по направлению коаксиальный кабель, кварцевые генераторы и конденсаторы (керамические, пленочные, электролитические), за счёт заключения дистрибьюторских договоров

Мы предлагаем:

- Конкуренспособные цены и скидки постоянным клиентам.
- Специальные условия для постоянных клиентов.
- Подбор аналогов.
- Поставку компонентов в любых объемах, удовлетворяющих вашим потребностям.
- Приемлемые сроки поставки, возможна ускоренная поставка.
- Доставку товара в любую точку России и стран СНГ.
- Комплексную поставку.
- Работу по проектам и поставку образцов.
- Формирование склада под заказчика.
- Сертификаты соответствия на поставляемую продукцию (по желанию клиента).
- Тестирование поставляемой продукции.
- Поставку компонентов, требующих военную и космическую приемку.
- Входной контроль качества.
- Наличие сертификата ISO.

В составе нашей компании организован Конструкторский отдел, призванный помогать разработчикам, и инженерам.

Конструкторский отдел помогает осуществить:

- Регистрацию проекта у производителя компонентов.
- Техническую поддержку проекта.
- Защиту от снятия компонента с производства.
- Оценку стоимости проекта по компонентам.
- Изготовление тестовой платы монтаж и пусконаладочные работы.



Тел: +7 (812) 336 43 04 (многоканальный)

Email: org@lifeelectronics.ru