

# DIFFERENTIAL-TO-LVDS/0.7V DIFFERENTIAL PCI EXPRESS™ JITTER ATTENUATOR

# ICS8741004I

## General Description



The ICS8741004I is a high performance Differential-to-LVDS/0.7V Differential Jitter Attenuator designed for use in PCI Express™ systems. In some PCI Express systems, such as those found in desktop PCs, the PCI Express clocks are generated from a low bandwidth, high phase noise PLL frequency synthesizer. In these systems, a jitter attenuator may be required to attenuate high frequency random and deterministic jitter components from the PLL synthesizer and from the system board. The ICS8741004I has 3 PLL bandwidth modes: 200kHz, 600kHz and 2MHz. The 200kHz mode will provide maximum jitter attenuation, but with higher PLL tracking skew and spread spectrum modulation from the motherboard synthesizer may be attenuated. The 600kHz provides an intermediate bandwidth that can easily track triangular spread profiles, while providing good jitter attenuation. The 2MHz bandwidth provides the best tracking skew and will pass most spread profiles, but the jitter attenuation will not be as good as the lower bandwidth modes. Because some 2.5Gb serdes have x20 multipliers while others have x25 multipliers, the ICS8741004I can be set for 1:1 mode or 5/4 multiplication mode (i.e. 100MHz input/125MHz output) using the F\_SEL pins.

The ICS8741004I uses IDT's 3<sup>rd</sup> Generation FemtoClock™ PLL technology to achieve the lowest possible phase noise. The device is packaged in a 24 Lead TSSOP package, making it ideal for use in space constrained applications such as PCI Express add-in cards.

### PLL Bandwidth

BW_SEL
0 = PLL Bandwidth: ~200kHz
Float = PLL Bandwidth: ~600kHz (default)
1 = PLL Bandwidth: ~2MHz

## Features

- Two LVDS and two 0.7V differential output pairs  
Bank A has two LVDS output pairs and Bank B has two 0.7V differential output pairs
- One differential clock input pair
- CLK, nCLK pair can accept the following differential input levels: LVPECL, LVDS, LVHSTL, SSTL, HCSL
- Output frequency range: 98MHz - 160MHz
- Input frequency range: 98MHz - 128MHz
- VCO range: 490MHz - 640MHz
- Cycle-to-cycle jitter: 35ps (maximum)
- Full 3.3V operating supply
- Three bandwidth modes allow the system designer to make jitter attenuation/tracking skew design trade-offs
- -40°C to 85°C ambient operating temperature
- Available in both standard (RoHS 5) and lead-free (RoHS 6) packages

## Pin Assignment

nQA1	1	24	nQB1
QA1	2	23	QB1
V <sub>DDO</sub>	3	22	V <sub>DDO</sub>
QA0	4	21	QB0
nQA0	5	20	nQB0
MR	6	19	IREF
BW_SEL	7	18	F_SELB
nc	8	17	OEB
V <sub>DDA</sub>	9	16	GND
F_SELA	10	15	GND
V <sub>DD</sub>	11	14	nCLK
OEA	12	13	CLK

**24-Lead TSSOP, E-Pad**  
**4.40mm x 7.8mm x 0.925mm**  
**package body**  
**G Package**  
**Top View**

The Preliminary Information presented herein represents a product in pre-production. The noted characteristics are based on initial product characterization and/or qualification. Integrated Device Technology, Incorporated (IDT) reserves the right to change any circuitry or specifications without notice.

### Block Diagram

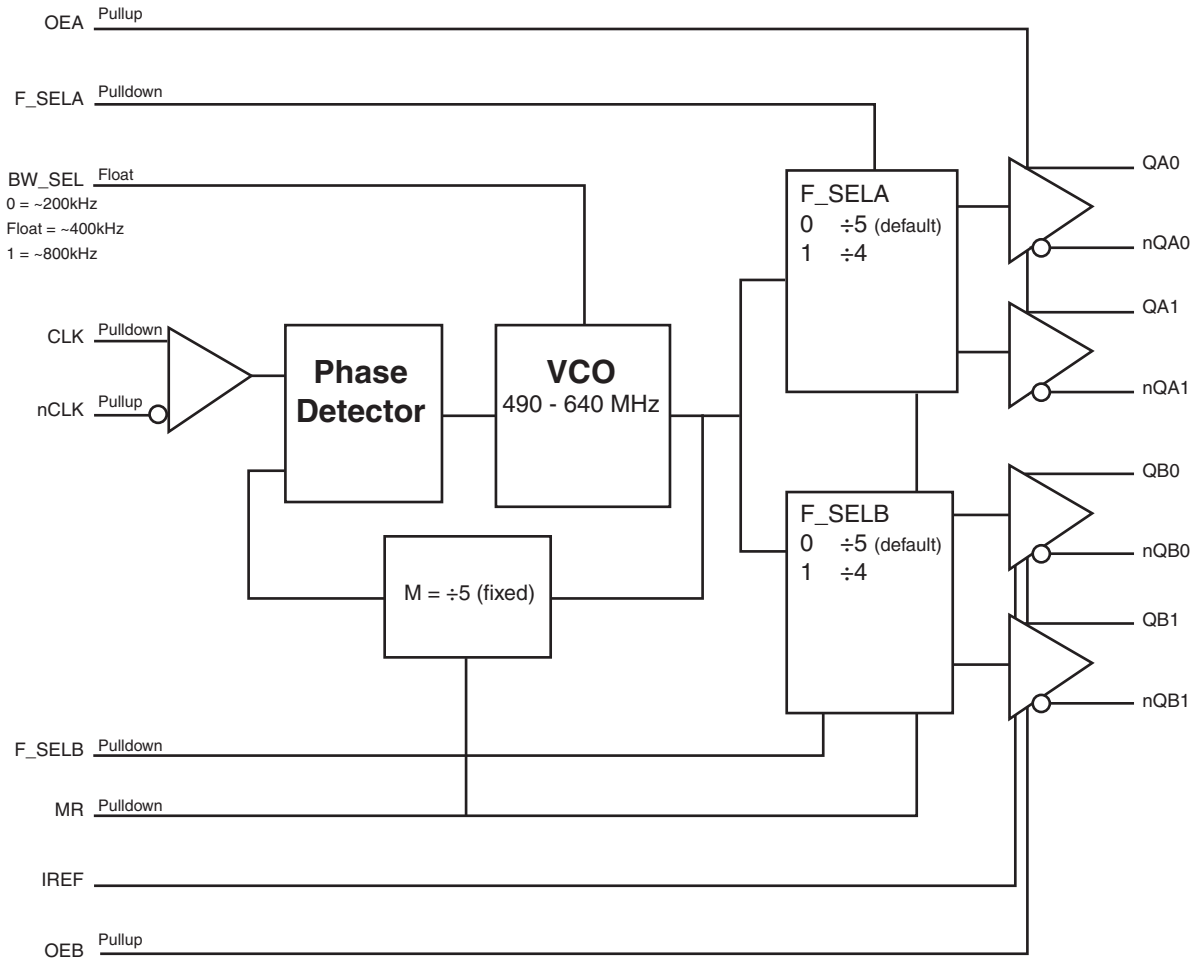

**Table 1. Pin Descriptions**

Number	Name	Type		Description
1, 24	nQA1, QA1	Output		Differential output pair. LVDS interface levels.
3, 22	V <sub>DDO</sub>	Power		Output supply pins.
4, 5	QA0, nQA0	Output		Differential output pair. LVDS interface levels.
6	MR	Input	Pulldown	Active High Master Reset. When logic HIGH, the internal dividers are reset causing the true outputs Q[Ax:Bx] to go LOW and the inverted outputs nQ[Ax:Bx] to go HIGH. When logic LOW, the internal dividers and the outputs are enabled. LVCMOS/LVTTL interface levels.
7	BW_SEL	Input	Pullup/ Pulldown	PLL Bandwidth input. LVCMOS/LVTTL interface levels. See Table 3B.
8	nc	Unused		No connect.
9	V <sub>DDA</sub>	Power		Analog supply pin.
10	F_SELA	Input	Pulldown	Frequency select pins for QAx/nQAx outputs. LVCMOS/LVTTL interface levels. See Table 3C.
11	V <sub>DD</sub>	Power		Core supply pin.
12	OEA	Input	Pullup	Output enable for QAx pins. When HIGH, QAx/nQAx outputs are enabled. When LOW, the QAx/nQAx outputs are in a high impedance state. LVCMOS/LVTTL interface levels. See Table 3A.
13	CLK	Input	Pulldown	Non-inverting differential clock input.
14	nCLK	Input	Pullup	Inverting differential clock input.
15, 16	GND	Power		Power supply ground.
17	OEB	Input	Pullup	Output enable for QBx pins. When HIGH, QBx/nQBx outputs are enabled. When LOW, the QBx/nQBx outputs are in a high impedance state. LVCMOS/LVTTL interface levels. See Table 3A.
18	F_SELB	Input	Pulldown	Frequency select pins for QBx/nQBx outputs. LVCMOS/LVTTL interface levels. See Table 3C.
19	IREF	Input		A fixed precision resistor (RREF = 475Ω) from this pin to ground provides a reference current used for differential current-mode QB0/nQB0 clock outputs.
20, 21	nQB0, QB0	Output		Differential output pair. HCSL interface levels.
23, 24	QB1, nQB1	Output		Differential output pair. HCSL interface levels.

NOTE: Pullup and Pulldown refer to internal input resistors. See Table 2, Pin Characteristics, for typical values.

**Table 2. Pin Characteristics**

Symbol	Parameter	Test Conditions	Minimum	Typical	Maximum	Units
C <sub>IN</sub>	Input Capacitance			4		pF
R <sub>PULLUP</sub>	Input Pullup Resistor			51		kΩ
R <sub>PULLDOWN</sub>	Input Pulldown Resistor			51		kΩ

## Function Tables

Table 3A. Output Enable Function Table

Inputs		Outputs	
OEA	OEB	QA[0:1]/nQA[0:1]	QB[0:1]/nQB[0:1]
0	0	Hi-Z	Hi-Z
1	1	Enabled	Enabled

Table 3B. PLL Bandwidth Function Table

Input	PLL Bandwidth
BW_SEL	
0	~200kHz
Float	~600kHz (default)
1	~2MHz

## Absolute Maximum Ratings

NOTE: Stresses beyond those listed under *Absolute Maximum Ratings* may cause permanent damage to the device. These ratings are stress specifications only. Functional operation of product at these conditions or any conditions beyond those listed in the *DC Characteristics* or *AC Characteristics* is not implied. Exposure to absolute maximum rating conditions for extended periods may affect product reliability.

Item	Rating
Supply Voltage, $V_{DD}$	4.6V
Inputs, $V_I$	-0.5V to $V_{DD} + 0.5V$
Outputs, $V_O$	-0.5V to $V_{DDO} + 0.5V$
Package Thermal Impedance, $\theta_{JA}$	32.1°C/W (0 mps)
Storage Temperature, $T_{STG}$	-65°C to 150°C

## DC Electrical Characteristics

Table 4A. Power Supply DC Characteristics,  $V_{DD} = V_{DDO} = 3.3V \pm 5\%$ ,  $T_A = -40^\circ C$  to  $85^\circ C$

Symbol	Parameter	Test Conditions	Minimum	Typical	Maximum	Units
$V_{DD}$	Positive Supply Voltage		3.135	3.3	3.465	V
$V_{DDA}$	Analog Supply Voltage		$V_{DD} - 0.12$	3.3	$V_{DD}$	V
$V_{DDO}$	Output Supply Voltage		3.135	3.3	3.465	V
$I_{DD}$	Power Supply Current				45	mA
$I_{DDA}$	Analog Supply Current				12	mA
$I_{DDO}$	Output Supply Current				80	mA

**Table 4B. LVCMOS/LVTTL DC Characteristics,  $V_{DD} = V_{DDO} = 3.3V \pm 5\%$ ,  $T_A = -40^\circ C$  to  $85^\circ C$** 

Symbol	Parameter	Test Conditions	Minimum	Typical	Maximum	Units
$V_{IH}$	Input High Voltage	OEA, OEB, MR, F_SELA, F_SELB	2		$V_{DD} + 0.3$	V
		BW_SEL	$V_{DD} - 0.3$		$V_{DD} + 0.3$	V
$V_{IL}$	Input Low Voltage	OEA, OEB, MR, F_SELA, F_SELB	-0.3		0.8	V
		BW_SEL	-0.3		+0.3	V
$V_{IM}$	Input Mid Voltage	BW_SEL	$V_{DD}/2 - 0.1$		$V_{DD}/2 + 0.1$	V
$I_{IH}$	Input High Current	F_SELA, F_SELB, MR, BW_SEL	$V_{DD} = V_{IN} = 3.465V$		150	$\mu A$
		OEA, OEB	$V_{DD} = V_{IN} = 3.465V$		5	$\mu A$
$I_{IL}$	Input Low Current	MR, F_SELA, F_SELB,	$V_{DD} = 3.465V, V_{IN} = 0V$	-5		$\mu A$
		OEA, OEB, BW_SEL	$V_{DD} = 3.465V, V_{IN} = 0V$	-150		$\mu A$

**Table 4C. Differential DC Characteristics,  $V_{DD} = V_{DDO} = 3.3V \pm 5\%$ ,  $T_A = -40^\circ C$  to  $85^\circ C$** 

Symbol	Parameter	Test Conditions	Minimum	Typical	Maximum	Units
$I_{IH}$	Input High Current	CLK	$V_{DD} = V_{IN} = 3.465V$		150	$\mu A$
		nCLK	$V_{DD} = V_{IN} = 3.465V$		5	$\mu A$
$I_{IL}$	Input Low Current	CLK	$V_{DD} = 3.465V,$ $V_{IN} = 0V$	-5		$\mu A$
		nCLK	$V_{DD} = 3.465V,$ $V_{IN} = 0V$	-150		$\mu A$
$V_{PP}$	Peak-to-Peak Voltage		0.15		1.3	V
$V_{CMR}$	Common Mode Input Voltage; NOTE 1		GND + 0.5		$V_{DD} - 0.85$	V

NOTE 1: Common mode input voltage is defined as  $V_{IH}$ .

**Table 4D. LVDS DC Characteristics,  $V_{DD} = V_{DDO} = 3.3V \pm 5\%$ ,  $T_A = -40^\circ C$  to  $85^\circ C$** 

Symbol	Parameter	Test Conditions	Minimum	Typical	Maximum	Units
$V_{OD}$	Differential Output Voltage		290	390	490	mV
$\Delta V_{OD}$	$V_{OD}$ Magnitude Change				50	mV
$V_{OS}$	Offset Voltage		1.2	1.35	1.5	V
$\Delta V_{OS}$	$V_{OS}$ Magnitude Change				50	mV

## AC Electrical Characteristics

Table 5. 0.7V Differential AC Characteristics,  $V_{DD} = V_{DDO} = 3.3V \pm 5\%$ ,  $T_A = -40^\circ C$  to  $85^\circ C$

Parameter	Symbol	Test Conditions	Minimum	Typical	Maximum	Units
$f_{MAX}$	Output Frequency		98		160	MHz
$f_{jit(cc)}$	Cycle-to-Cycle Jitter; NOTE 1				35	ps
$t_{sk(b)}$	Bank Skew; NOTE 2				30	ps
$V_{HIGH}$	Output Voltage High	QBx/nQBx	530		870	mV
$V_{LOW}$	Output Voltage Low	QBx/nQBx	-150			mV
$V_{OVS}$	Max. Voltage, Overshoot	QBx/nQBx			$V_{HIGH} + 0.35$	V
$V_{UDS}$	Min. Voltage, Undershoot	QBx/nQBx	-0.3			V
$V_{rb}$	Ringback Voltage	QBx/nQBx			0.2	V
$V_{CROSS}$	Absolute Crossing Voltage	QBx/nQBx	@ 0.7V Swing	250	550	mV
$\Delta V_{CROSS}$	Total Variation of $V_{CROSS}$ over all edges	QBx/nQBx	@ 0.7V Swing		140	mV
$t_R / t_F$	Output Rise/Fall Time	QBx/nQBx	measured between 0.175V to 0.525V	175	700	ps
		QAx/nQAx	20% to 80%	250	600	ps
$\Delta t_R / \Delta t_F$	Rise/Fall Time Variation	QBx/nQBx			125	ps
$t_{RFM}$	Rise/Fall Matching	QBx/nQBx			20	%
odc	Output Duty Cycle		48		52	%

NOTE 1: This parameter is defined in accordance with JEDEC Standard 65.

NOTE 2: Defined as skew within a bank of outputs at the same voltage and with equal load conditions.

### Parameter Measurement Information

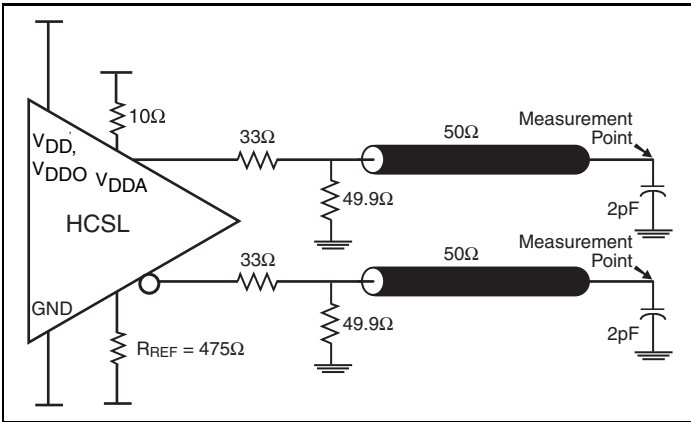

3.3V HCSL Output Load AC Test Circuit

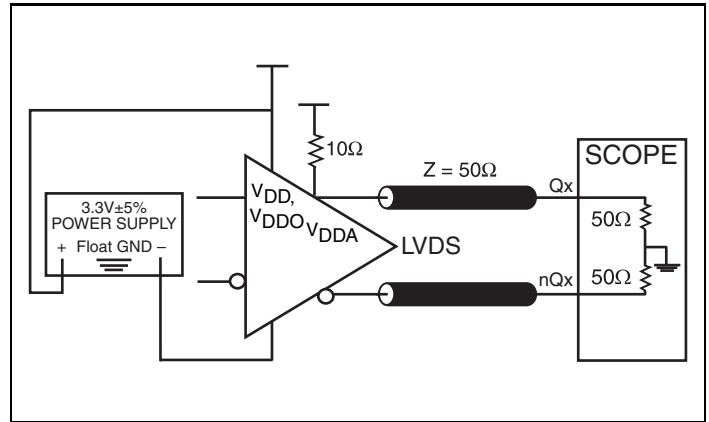

3.3V LVDS Output Load AC Test Circuit

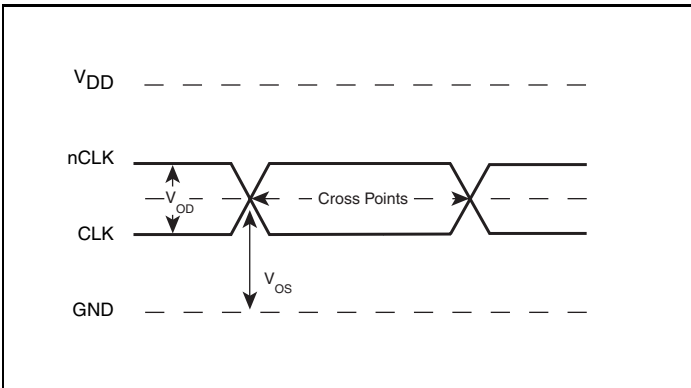

Differential Input Level

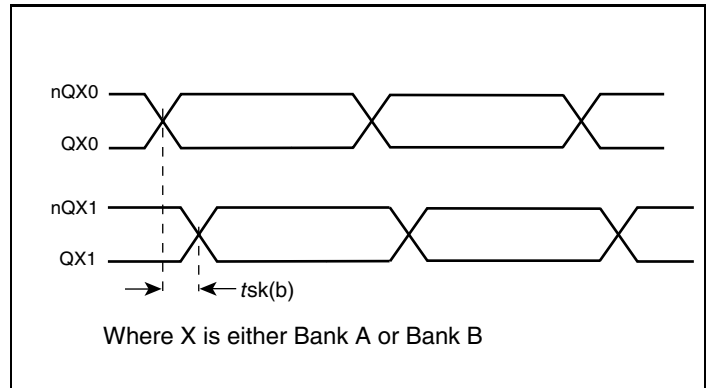

Bank Skew

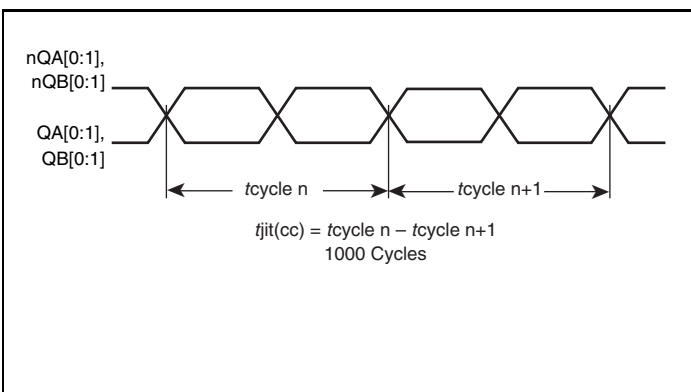

Cycle-to-Cycle Jitter

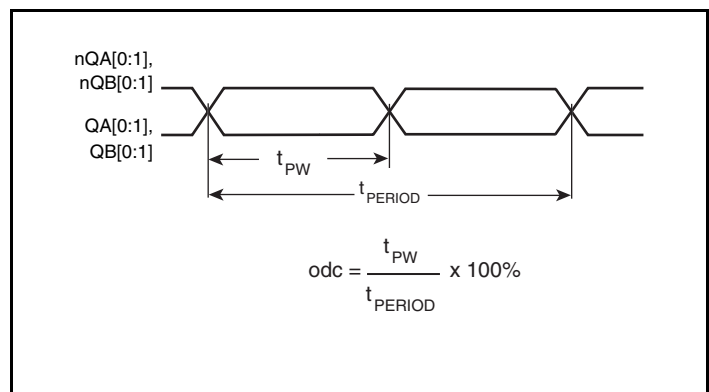

Output Duty Cycle/Pulse Width/Period

## Parameter Measurement Information, continued

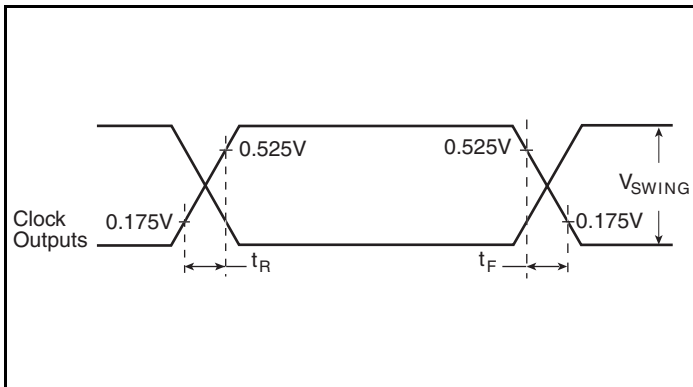

HCSL Output Rise/Fall Time

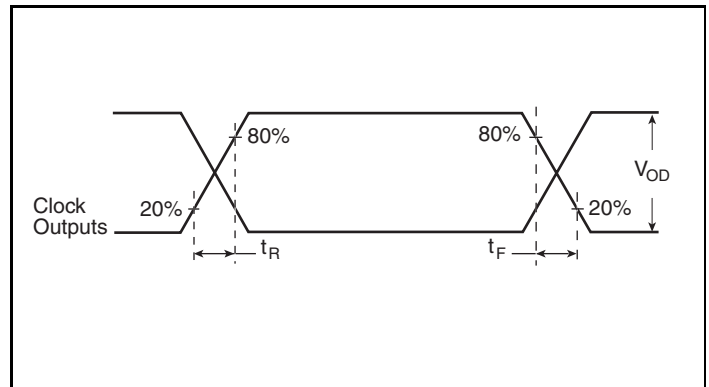

LVDS Output Rise/Fall Time

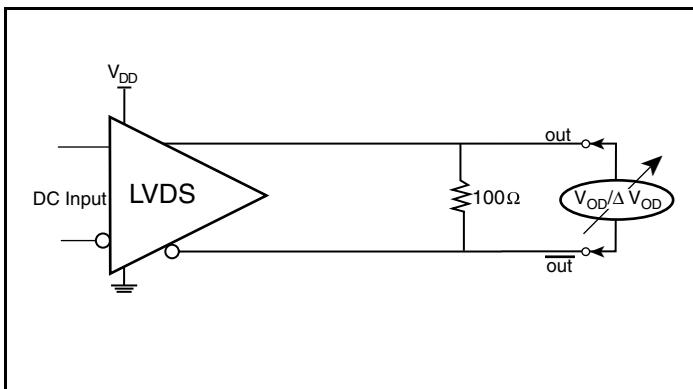

Differential Output Voltage Setup

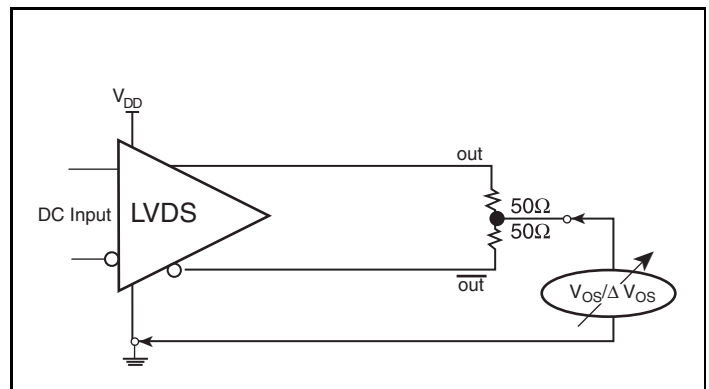

Offset Voltage Setup



## Application Information

### Power Supply Filtering Technique

As in any high speed analog circuitry, the power supply pins are vulnerable to random noise. To achieve optimum jitter performance, power supply isolation is required. The ICS8741004I provides separate power supplies to isolate any high switching noise from the outputs to the internal PLL.  $V_{DD}$ ,  $V_{DDA}$  and  $V_{DDO}$  should be individually connected to the power supply plane through vias, and  $0.01\mu\text{F}$  bypass capacitors should be used for each pin. *Figure 1* illustrates this for a generic  $V_{DD}$  pin and also shows that  $V_{DDA}$  requires that an additional  $10\Omega$  resistor along with a  $10\mu\text{F}$  bypass capacitor be connected to the  $V_{DDA}$  pin.

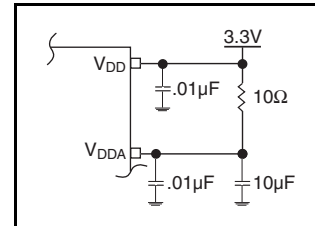

Figure 1. Power Supply Filtering

### Wiring the Differential Input to Accept Single Ended Levels

*Figure 2* shows how the differential input can be wired to accept single ended levels. The reference voltage  $V_{REF} = V_{DD}/2$  is generated by the bias resistors  $R1$ ,  $R2$  and  $C1$ . This bias circuit should be located as close as possible to the input pin. The ratio of

$R1$  and  $R2$  might need to be adjusted to position the  $V_{REF}$  in the center of the input voltage swing. For example, if the input clock swing is only  $2.5\text{V}$  and  $V_{DD} = 3.3\text{V}$ ,  $V_{REF}$  should be  $1.25\text{V}$  and  $R2/R1 = 0.609$ .

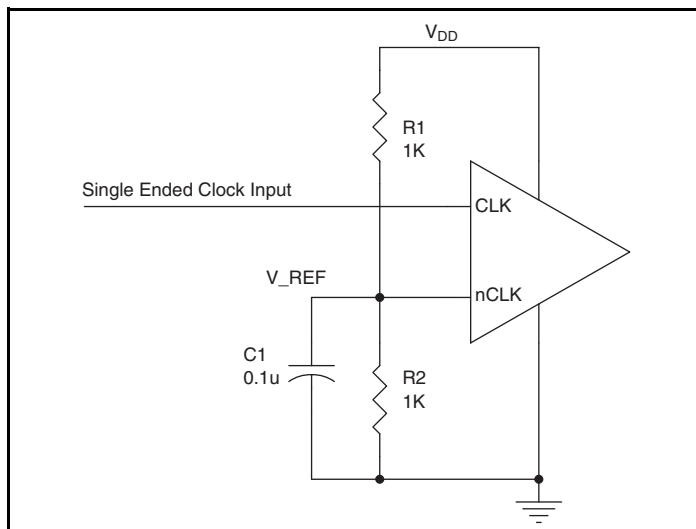
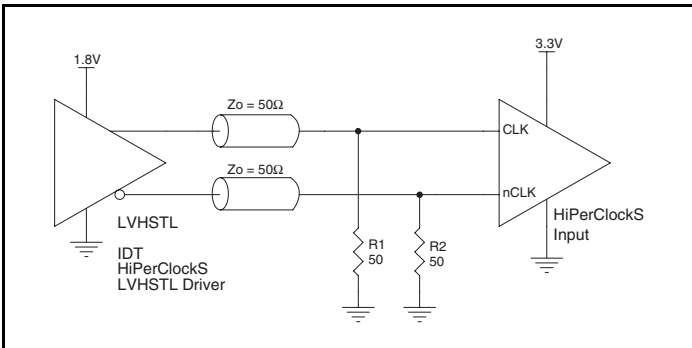

Figure 2. Single-Ended Signal Driving Differential Input

### Differential Clock Input Interface

The CLK /nCLK accepts LVDS, LVPECL, LVHSTL, SSTL, HCSL and other differential signals. Both  $V_{SWING}$  and  $V_{OH}$  must meet the  $V_{PP}$  and  $V_{CMR}$  input requirements. Figures 3A to 3F show interface examples for the HiPerClockS CLK/nCLK input driven by the most common driver types. The input interfaces suggested here are examples only. Please consult with the vendor of the driver

component to confirm the driver termination requirements. For example, in Figure 3A, the input termination applies for IDT HiPerClockS open emitter LVHSTL drivers. If you are using an LVHSTL driver from another vendor, use their termination recommendation.



**Figure 3A. HiPerClockS CLK/nCLK Input Driven by an IDT Open Emitter HiPerClockS LVHSTL Driver**

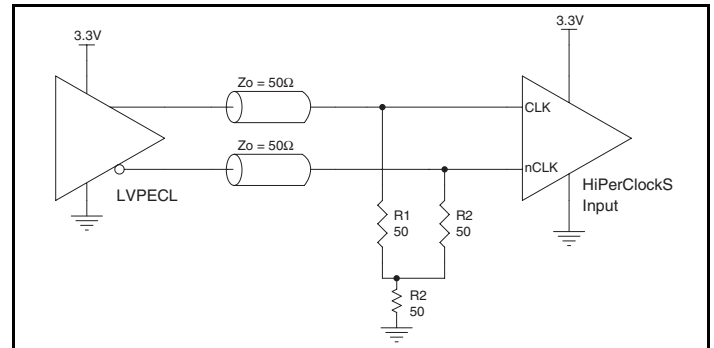

**Figure 3B. HiPerClockS CLK/nCLK Input Driven by a 3.3V LVPECL Driver**

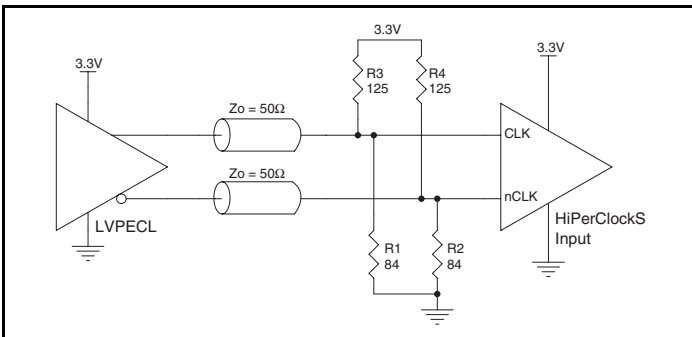

**Figure 3C. HiPerClockS CLK/nCLK Input Driven by a 3.3V LVPECL Driver**

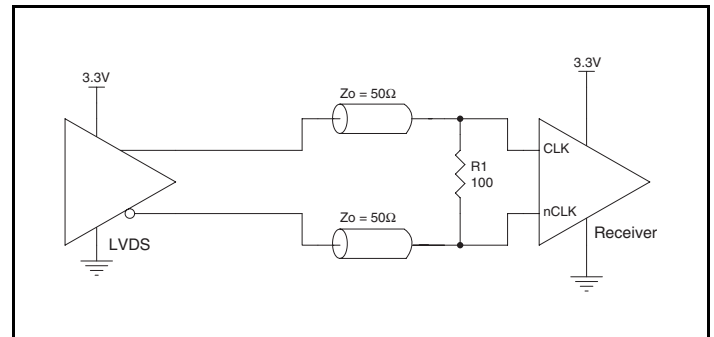

**Figure 3D. HiPerClockS CLK/nCLK Input Driven by a 3.3V LVDS Driver**

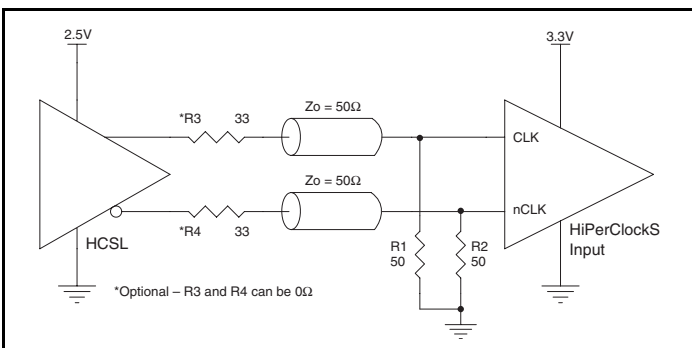

**Figure 3E. HiPerClockS CLK/nCLK Input Driven by a 3.3V HCSL Driver**

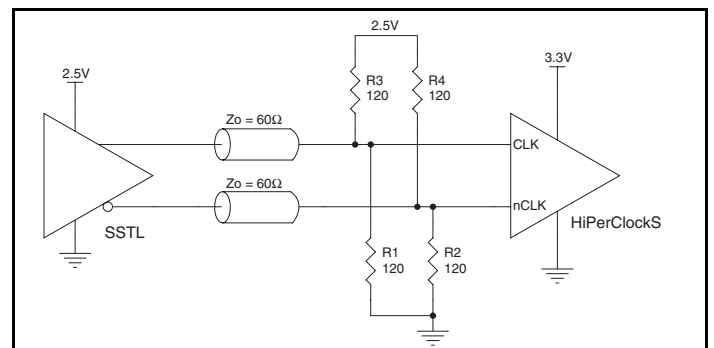

**Figure 3F. HiPerClockS CLK/nCLK Input Driven by a 2.5V SSTL Driver**

## Recommendations for Unused Input and Output Pins

### Inputs:

#### LVC MOS Control Pins

All control pins have internal pull-ups or pull-downs; additional resistance is not required but can be added for additional protection. A 1k $\Omega$  resistor can be used.

### Outputs:

#### Differential Outputs

All unused differential outputs can be left floating. We recommend that there is no trace attached. Both sides of the differential output pair should either be left floating or terminated.

#### LVDS Outputs

All unused LVDS output pairs can be either left floating or terminated with 100 $\Omega$  across. If they are left floating, we recommend that there is no trace attached.

## LVDS Driver Termination

A general LVDS interface is shown in *Figure 4*. In a 100 $\Omega$  differential transmission line environment, LVDS drivers require a matched load termination of 100 $\Omega$  across near the receiver input.

For a multiple LVDS outputs buffer, if only partial outputs are used, it is recommended to terminate the unused outputs.

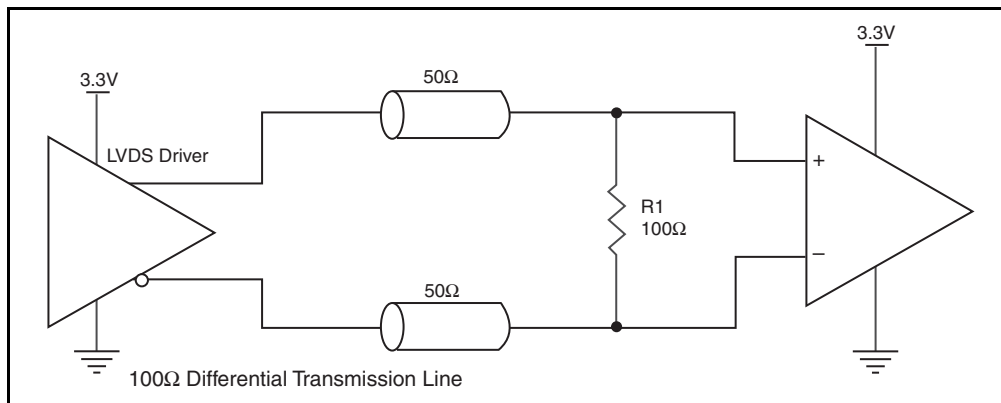

Figure 4. Typical LVDS Driver Termination

## Recommended Termination

Figure 5A is the recommended termination for applications which require the receiver and driver to be on a separate PCB. All traces should be 50Ω impedance.

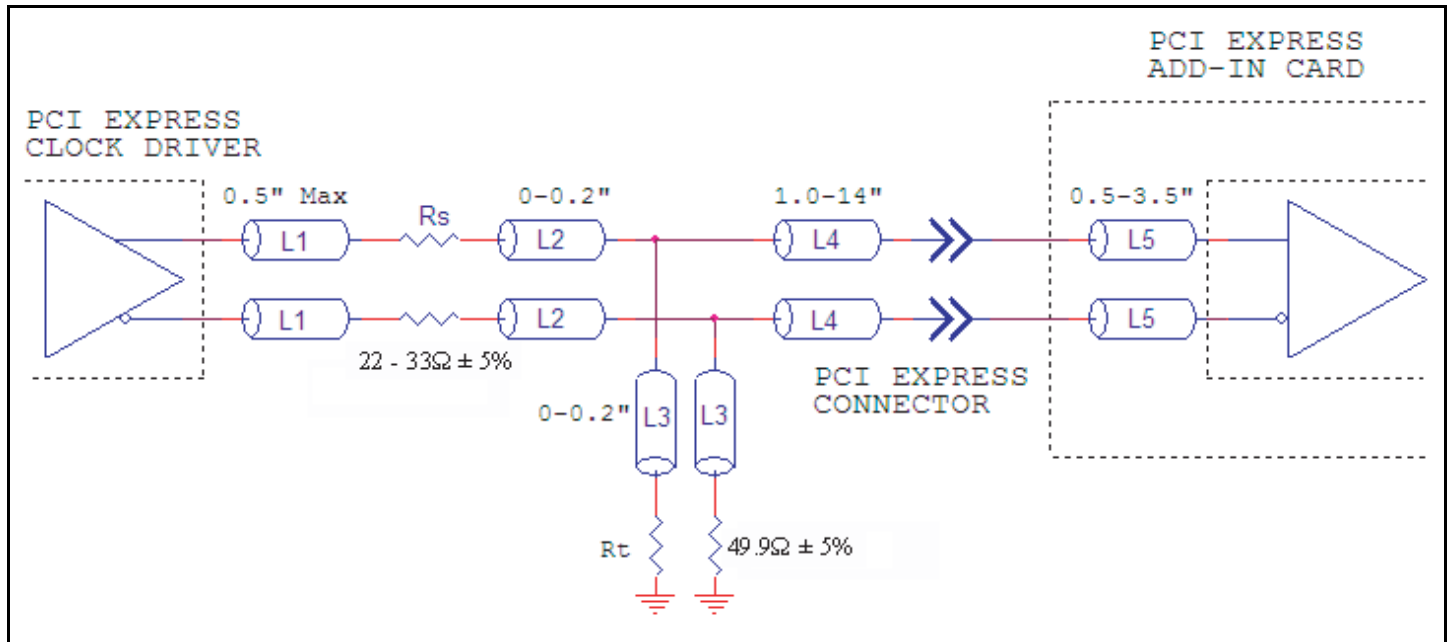

Figure 5A. Recommended Termination

Figure 5B is the recommended termination for applications which require a point to point connection and contain the driver and receiver on the same PCB. All traces should all be 50Ω impedance.

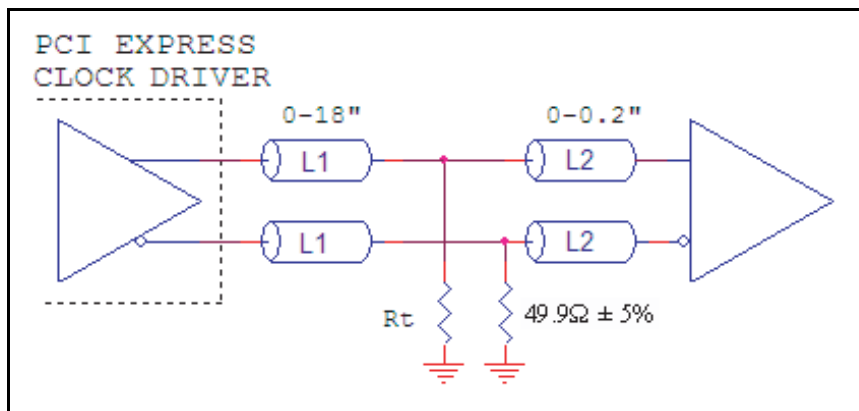
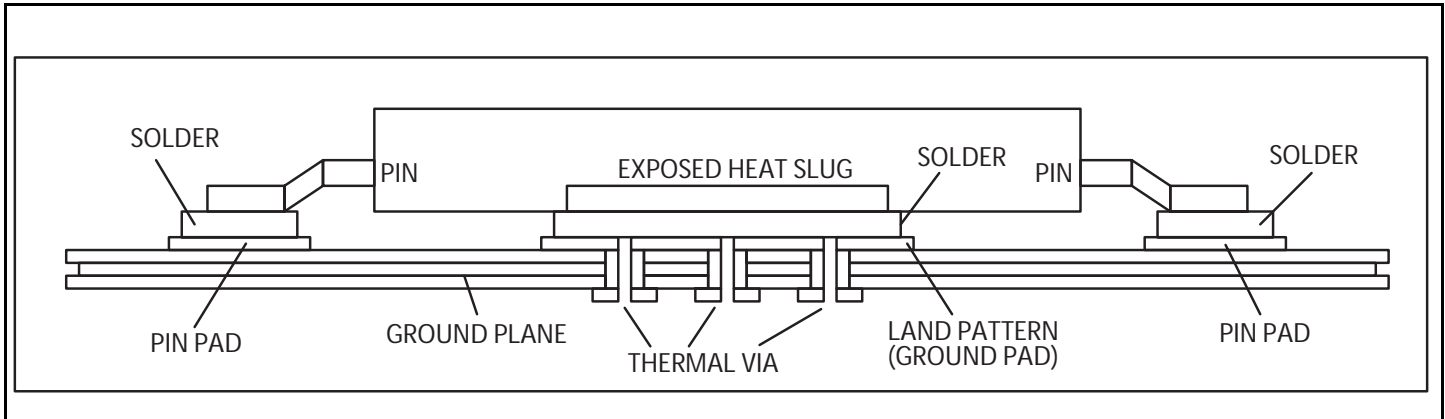

Figure 5B. Recommended Termination

## Thermal Release Path

The expose metal pad provides heat transfer from the device to the P.C. board. The expose metal pad is ground pad connected to ground plane through thermal via. The exposed pad on the device to the exposed metal pad on the PCB is contacted through solder

as shown in *Figure 6*. For further information, please refer to the Application Note on *Surface Mount Assembly of Amkor's Thermally /Electrically Enhance Leadframe Base Package*, Amkor Technology.



**Figure 6. P.C. Board for Exposed Pad Thermal Release Path Example**

### Schematic Example

Figure 7 shows an example of ICS8741004I application schematic. In this example, the device is operated at  $V_{DD} = V_{DDO} = 3.3V$ . Two examples of LVDS terminations and two examples of HCSL

terminations are shown in this schematic. The input is driven by a 3.3V LVPECL driver. The decoupling capacitors should be located as close as possible to the power pin.

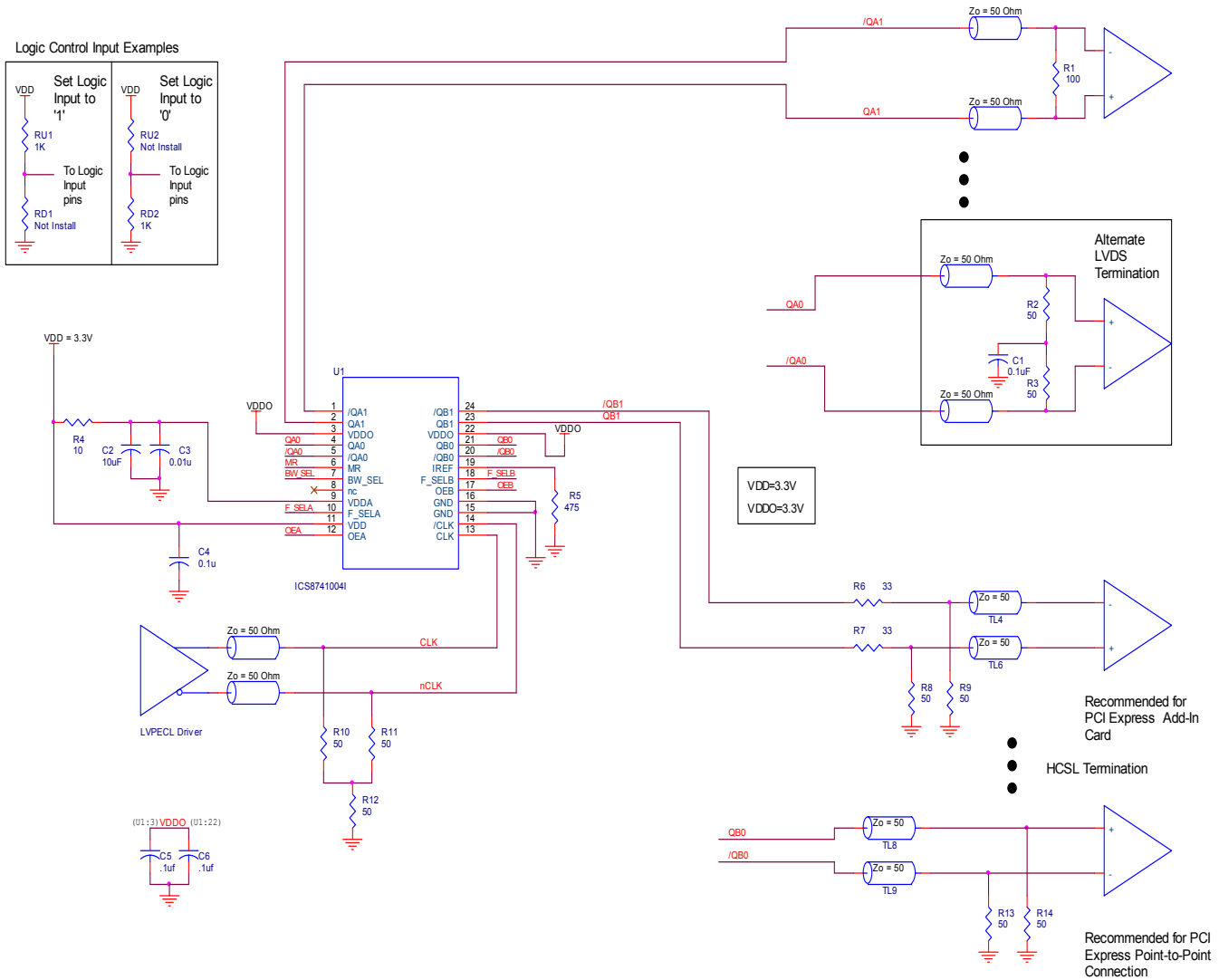

Figure 7. ICS8741004I Schematic Example

## Power Considerations

This section provides information on power dissipation and junction temperature for the ICS8741004I. Equations and example calculations are also provided.

### 1. Power Dissipation.

The total power dissipation for the ICS8741004I is the sum of the core power plus the analog power plus the power dissipated in the load(s). The following is the power dissipation for  $V_{DD} = 3.3V + 5\% = 3.465V$ , which gives worst case results.

NOTE: Please refer to Section 3 for details on calculating power dissipated in the load.

- Power (core)<sub>MAX</sub> =  $V_{DD\_MAX} * (I_{DD\_MAX} + I_{DDA\_MAX}) = 3.465V * (45mA + 12mA) = \mathbf{197.5mW}$
- Power (LVDS\_output)<sub>MAX</sub> =  $V_{DDO\_MAX} * I_{DDO\_MAX} = 3.465V * 80mA = \mathbf{227.2mW}$
- Power (HCSL\_output)<sub>MAX</sub> =  $45.65mW * 2 = \mathbf{91.3mW}$

**Total Power<sub>MAX</sub>** = (3.465V, with all outputs switching) =  $197.5mW + 277.2mW + 91.3mW = \mathbf{556mW}$

### 2. Junction Temperature.

Junction temperature,  $T_j$ , is the temperature at the junction of the bond wire and bond pad and directly affects the reliability of the device. The maximum recommended junction temperature for HiPerClockS devices is 125°C.

The equation for  $T_j$  is as follows:  $T_j = \theta_{JA} * Pd\_total + T_A$

$T_j$  = Junction Temperature

$\theta_{JA}$  = Junction-to-Ambient Thermal Resistance

$Pd\_total$  = Total Device Power Dissipation (example calculation is in section 1 above)

$T_A$  = Ambient Temperature

In order to calculate junction temperature, the appropriate junction-to-ambient thermal resistance  $\theta_{JA}$  must be used. Assuming no air flow and a multi-layer board, the appropriate value is 32.1°C/W per Table 6 below.

Therefore,  $T_j$  for an ambient temperature of 85°C with all outputs switching is:

$$85^\circ\text{C} + 0.556\text{W} * 32.1^\circ\text{C/W} = 102.8^\circ\text{C}. \text{ This is below the limit of } 125^\circ\text{C}.$$

This calculation is only an example.  $T_j$  will obviously vary depending on the number of loaded outputs, supply voltage, air flow and the type of board (single layer or multi-layer).

**Table 6. Thermal Resistance  $\theta_{JA}$  for 24 Lead TSSOP, E-Pad, Forced Convection**

$\theta_{JA}$ Vs. Air Flow			
Meters per Second	0	1	2.5
Multi-Layer PCB, JEDEC Standard Test Boards	32.1°C/W	25.5°C/W	24.0°C/W

### 3. Calculations and Equations.

The purpose of this section is to calculate power dissipation on the IC per HCSL output pair.

HCSL output driver circuit and termination are shown in *Figure 8*.

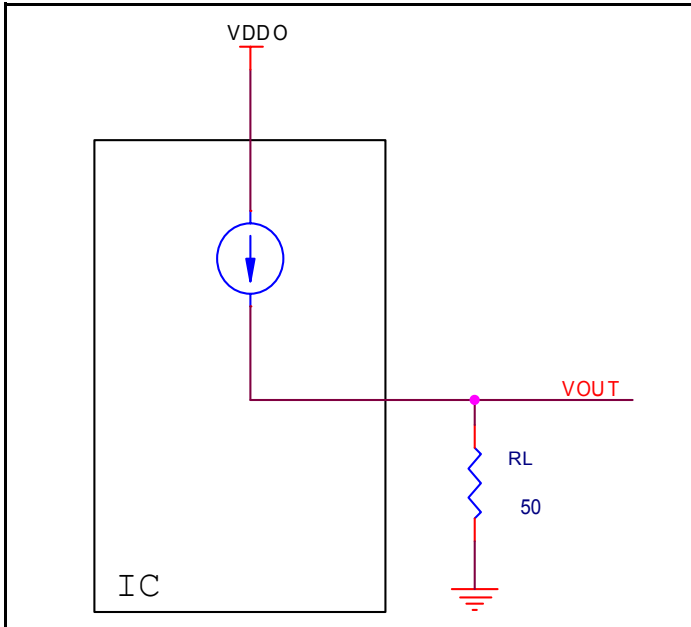

**Figure 8. LVHSTL Driver Circuit and Termination**

To calculate worst case power dissipation into the load, use the following equations which assume a  $50\Omega$  load and a termination voltage of  $V_{CCO} - 2V$ .

$Pd\_H$  is power dissipation when the output drives high.

$Pd\_L$  is the power dissipation when the output drives low.

$$Pd\_H = (V_{OH\_MAX}/R_L) * (V_{DD\_MAX} - V_{OH\_MAX})$$

$$Pd\_L = (V_{OL\_MIN}/R_L) * (V_{DD\_MAX} - V_{OL\_MIN})$$

$$Pd\_H = (0.85V/50\Omega) * (3.465V - 0.87V) = \mathbf{44.1mW}$$

$$Pd\_L = (0.15V/50\Omega) * 0.15V = \mathbf{0.45mW}$$

$$\text{Total Power Dissipation per output pair} = Pd\_H + Pd\_L = \mathbf{45mW}$$



## Reliability Information

Table 7.  $\theta_{JA}$  vs. Air Flow Table for a 24 Lead TSSOP, E-Pad

$\theta_{JA}$ vs. Air Flow			
Meters per Second	0	1	2.5
Multi-Layer PCB, JEDEC Standard Test Boards	32.1°C/W	25.5°C/W	24.0°C/W

## Transistor Count

The transistor count for ICS8741004I is: 1318

# Package Outline and Package Dimension

Package Outline - G Suffix for 24 Lead TSSOP, E-Pad

Table 9. Package Dimensions

All Dimensions in Millimeters			
Symbol	Minimum	Nominal	Maximum
N	24		
A			1.10
A1	0.05		0.15
A2	0.85	0.90	0.95
b	0.19		0.30
b1	0.19	0.22	0.25
c	0.09		0.20
c1	0.09	0.127	0.16
D	7.70		7.90
E	6.40 Basic		
E1	4.30	4.40	4.50
e	0.65 Basic		
L	0.50	0.60	0.70
P	5.0		5.5
P1	3.0		3.2
$\alpha$	0°		8°
$\alpha\alpha\alpha$	0.076		
bbb	0.10		

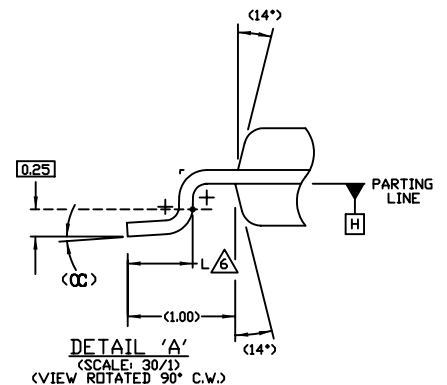
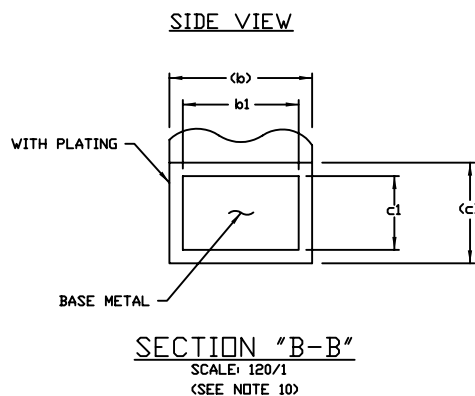
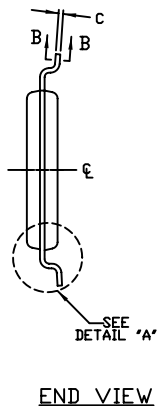
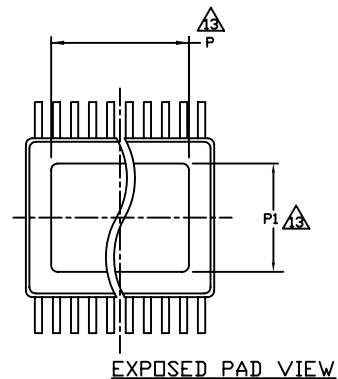
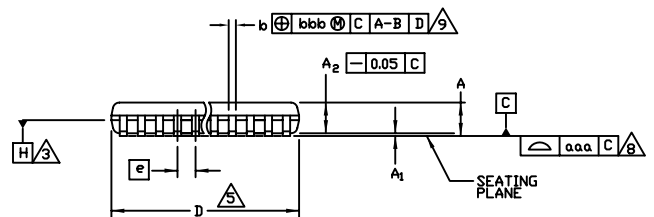
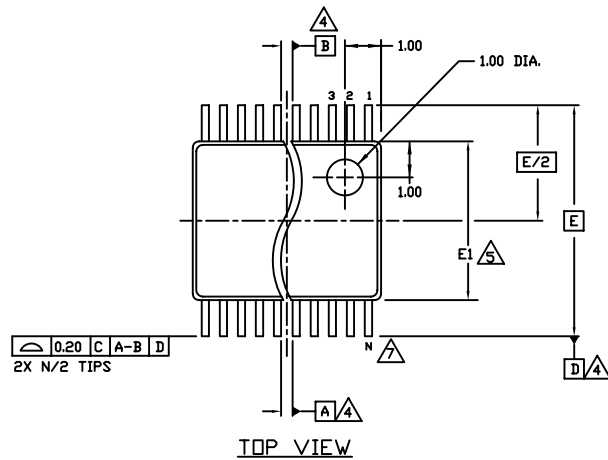

## Ordering Information

Table 9. Ordering Information

Part/Order Number	Marking	Package	Shipping Packaging	Temperature
8741004BGI	ICS8741004BGI	24 Lead TSSOP, E-Pad	Tray	-40°C to 85°C
8741004BGIT	ICS8741004BGI	24 Lead TSSOP, E-Pad	2500 Tape & Reel	-40°C to 85°C
8741004BGILF	ICS8741004BIL	"Lead-Free" 24 Lead TSSOP, E-Pad	Tray	-40°C to 85°C
8741004BGILFT	ICS8741004BIL	"Lead-Free" 24 Lead TSSOP, E-Pad	2500 Tape & Reel	-40°C to 85°C

NOTE: Parts that are ordered with an "LF" suffix to the part number are the Pb-Free configuration and are RoHS compliant.

While the information presented herein has been checked for both accuracy and reliability, Integrated Device Technology (IDT) assumes no responsibility for either its use or for the infringement of any patents or other rights of third parties, which would result from its use. No other circuits, patents, or licenses are implied. This product is intended for use in normal commercial and industrial applications. Any other applications, such as those requiring high reliability or other extraordinary environmental requirements are not recommended without additional processing by IDT. IDT reserves the right to change any circuitry or specifications without notice. IDT does not authorize or warrant any IDT product for use in life support devices or critical medical instruments.

Innovate with IDT and accelerate your future networks. Contact:

**www.IDT.com**

**For Sales**

800-345-7015  
408-284-8200  
Fax: 408-284-2775

**For Tech Support**

netcom@idt.com  
480-763-2056

---

**Corporate Headquarters**

Integrated Device Technology, Inc.  
6024 Silver Creek Valley Road  
San Jose, CA 95138  
United States  
800 345 7015  
+408 284 8200 (outside U.S.)

**Asia Pacific and Japan**

Integrated Device Technology  
Singapore (1997) Pte. Ltd.  
Reg. No. 199707558G  
435 Orchard Road  
#20-03 Wisma Atria  
Singapore 238877  
+65 6 887 5505

**Europe**

IDT Europe, Limited  
321 Kingston Road  
Leatherhead, Surrey  
KT22 7TU  
England  
+44 (0) 1372 363 339  
Fax: +44 (0) 1372 378851

Компания «Life Electronics» занимается поставками электронных компонентов импортного и отечественного производства от производителей и со складов крупных дистрибьюторов Европы, Америки и Азии.

С конца 2013 года компания активно расширяет линейку поставок компонентов по направлению коаксиальный кабель, кварцевые генераторы и конденсаторы (керамические, пленочные, электролитические), за счёт заключения дистрибьюторских договоров

Мы предлагаем:

- Конкурентоспособные цены и скидки постоянным клиентам.
- Специальные условия для постоянных клиентов.
- Подбор аналогов.
- Поставку компонентов в любых объемах, удовлетворяющих вашим потребностям.
- Приемлемые сроки поставки, возможна ускоренная поставка.
- Доставку товара в любую точку России и стран СНГ.
- Комплексную поставку.
- Работу по проектам и поставку образцов.
- Формирование склада под заказчика.
- Сертификаты соответствия на поставляемую продукцию (по желанию клиента).
- Тестирование поставляемой продукции.
- Поставку компонентов, требующих военную и космическую приемку.
- Входной контроль качества.
- Наличие сертификата ISO.

В составе нашей компании организован Конструкторский отдел, призванный помогать разработчикам, и инженерам.

Конструкторский отдел помогает осуществить:

- Регистрацию проекта у производителя компонентов.
- Техническую поддержку проекта.
- Защиту от снятия компонента с производства.
- Оценку стоимости проекта по компонентам.
- Изготовление тестовой платы монтаж и пусконаладочные работы.



Тел: +7 (812) 336 43 04 (многоканальный)  
Email: [org@lifeelectronics.ru](mailto:org@lifeelectronics.ru)