

NCS2220A

Low Voltage Comparator

The NCS2220A is an industry first sub-one volt, low power dual comparator. This device consumes only 0.85 μ A per Comparator of supply current. It is guaranteed to operate at a low voltage of 0.85 V which allows it to be used in systems that require less than 1.0 V and is fully operational up to 6.0 V. Additional features include no output phase inversion with overdriven inputs, internal hysteresis, which allows for clean output switching, and rail-to-rail input and output performance. The NCS2220A is available in the tiny UDFN 1.6 X 1.6 package.

Features

- Operating Voltage of 0.85 V to 6.0 V
- Rail-to-Rail Input/Output Performance
- Low Supply Current of 7.5 μ A per Comparator Typ
- No Phase Inversion with Overdriven Input Signals
- Internal Hysteresis
- Propagation Delay of 0.5 μ s
- These are Pb-Free Devices

Typical Applications

- Single Cell NiCd/NiMH Battery Powered Applications
- Cellular Telephones
- Alarm and Security Systems
- Personal Digital Assistants



ON Semiconductor®

<http://onsemi.com>



UDFN8 1.6 X 1.6
MU SUFFIX
CASE 517AC

MARKING DIAGRAMS

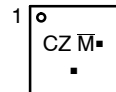

CZ = Specific Device Code
M = Date Code
▪ = Pb-Free Package

(Note: Microdot may be in either location)

ORDERING INFORMATION

Device	Package	Shipping†
NCS2220AMUT1G	UDFN8 (Pb-Free)	3000/ Tape & Reel

†For information on tape and reel specifications, including part orientation and tape sizes, please refer to our Tape and Reel Packaging Specification Brochure, BRD8011/D.

NCS2220A

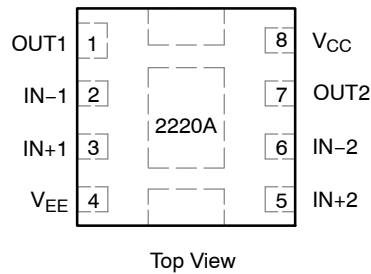

NOTE: The NCS2220A has three exposed pads on the bottom side which may be used to reduce thermal resistance by soldering to a copper heat-spreader. Electrically the exposed pads must be allowed to float.

Figure 1. Pin Connections

MAXIMUM RATINGS

Rating	Symbol	Value	Unit
Supply Voltage Range (V_{CC} to V_{EE})	V_S	6.0	V
Non-inverting/Inverting Input to V_{EE}	–	–0.2 to ($V_{CC} + 0.2$)	V
Operating Junction Temperature	T_J	150	°C
Operating Ambient Temperature	T_A	–40 to +105	°C
Storage Temperature Range	T_{stg}	–65 to +150	°C
Output Short Circuit Duration Time (Note 1)	t_S	Indefinite	s
ESD Tolerance (Note 2) Human Body Model Machine Model	–	2000 200	V
Thermal Resistance, Junction-to-Ambient UDFN	$R_{\theta JA}$	350	°C/W

Stresses exceeding Maximum Ratings may damage the device. Maximum Ratings are stress ratings only. Functional operation above the Recommended Operating Conditions is not implied. Extended exposure to stresses above the Recommended Operating Conditions may affect device reliability.

1. The maximum package power dissipation limit must not be exceeded.

$$P_D = \frac{T_{J(max)} - T_A}{R_{\theta JA}}$$

2. ESD data available upon request.

NCS2220A

ELECTRICAL CHARACTERISTICS (For all values $V_{CC} = 0.85\text{ V}$ to 6.0 V , $V_{EE} = 0\text{ V}$, $T_A = 25^\circ\text{C}$, unless otherwise noted.) (Note 3)

Characteristics	Symbol	Min	Typ	Max	Unit
Input Hysteresis $T_A = 25^\circ\text{C}$	V_{HYS}	2.0	4.5	20	mV
Input Offset Voltage $V_{CC} = 0.85\text{ V}$ $T_A = 25^\circ\text{C}$ $T_A = -40^\circ\text{C}$ to 105°C $V_{CC} = 3.0\text{ V}$ $T_A = 25^\circ\text{C}$ $T_A = -40^\circ\text{C}$ to 105°C $V_{CC} = 6.0\text{ V}$ $T_A = 25^\circ\text{C}$ $T_A = -40^\circ\text{C}$ to 105°C	V_{IO}	-10 -12	0.5 -	+10 +12	mV
Common Mode Voltage Range	V_{CM}	-	V_{EE} to V_{CC}	-	V
Output Short-Circuit Sourcing or Sinking	I_{SC}	-	60	-	mA
Common Mode Rejection Ratio $V_{CM} = V_{CC}$	CMRR	53	70	-	dB
Input Bias Current	I_{IB}	-	1.0	-	pA
Power Supply Rejection Ratio $\Delta V_S = 2.575\text{ V}$	PSRR	45	80	-	dB
Supply Current per Comparator $V_{CC} = 0.85\text{ V}$ $T_A = 25^\circ\text{C}$ $T_A = -40^\circ\text{C}$ to 105°C $V_{CC} = 3.0\text{ V}$ $T_A = 25^\circ\text{C}$ $T_A = -40^\circ\text{C}$ to 105°C $V_{CC} = 6.0\text{ V}$ $T_A = 25^\circ\text{C}$ $T_A = -40^\circ\text{C}$ to 105°C	I_{CC}	-	7.5 -	15 17	μA
Output Voltage High $V_{CC} = 0.85\text{ V}$, $I_{source} = 0.5\text{ mA}$ $T_A = 25^\circ\text{C}$ $T_A = -40^\circ\text{C}$ to 105°C $V_{CC} = 3.0\text{ V}$, $I_{source} = 3.0\text{ mA}$ $T_A = 25^\circ\text{C}$ $T_A = -40^\circ\text{C}$ to 105°C $V_{CC} = 6.0\text{ V}$, $I_{source} = 5.0\text{ mA}$ $T_A = 25^\circ\text{C}$ $T_A = -40^\circ\text{C}$ to 105°C	V_{OH}	$V_{CC} - 0.25$ $V_{CC} - 0.275$	$V_{CC} - 0.12$ -	-	V
Output Voltage Low $V_{CC} = 0.85\text{ V}$, $I_{sink} = 0.5\text{ mA}$ $T_A = 25^\circ\text{C}$ $T_A = -40^\circ\text{C}$ to 105°C $V_{CC} = 3.0\text{ V}$, $I_{sink} = 3.0\text{ mA}$ $T_A = 25^\circ\text{C}$ $T_A = -40^\circ\text{C}$ to 105°C $V_{CC} = 6.0\text{ V}$, $I_{sink} = 5.0\text{ mA}$ $T_A = 25^\circ\text{C}$ $T_A = -40^\circ\text{C}$ to 105°C	V_{OL}	-	$V_{EE} + 0.10$ -	$V_{EE} + 0.25$ $V_{EE} + 0.275$	V
Propagation Delay 20 mV Overdrive, $C_L = 15\text{ pF}$	t_{PHL} t_{PLH}	-	0.5 0.5	-	μs
Output Fall Time $V_{CC} = 6.0\text{ V}$, $C_L = 50\text{ pF}$ (Note 4)	t_{FALL}	-	20	-	ns
Output Rise Time $V_{CC} = 6.0\text{ V}$, $C_L = 50\text{ pF}$ (Note 4)	t_{RISE}	-	16	-	ns

3. The limits over the extended temperature range are guaranteed by design only.

4. Input signal: 1 kHz, squarewave signal with 10 ns edge rate.

NCS2220A

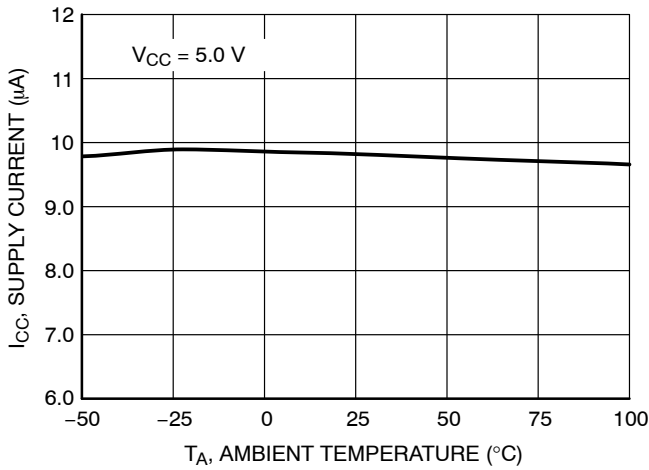

Figure 1. Supply Current versus Temperature/Comparator

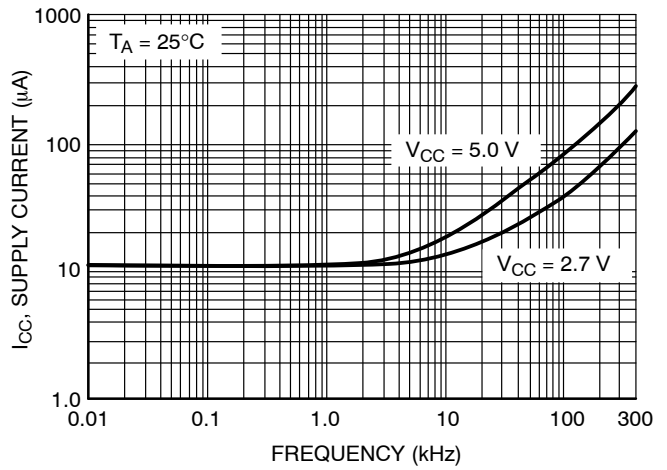

Figure 2. Supply Current versus Output Transition Frequency/Comparator

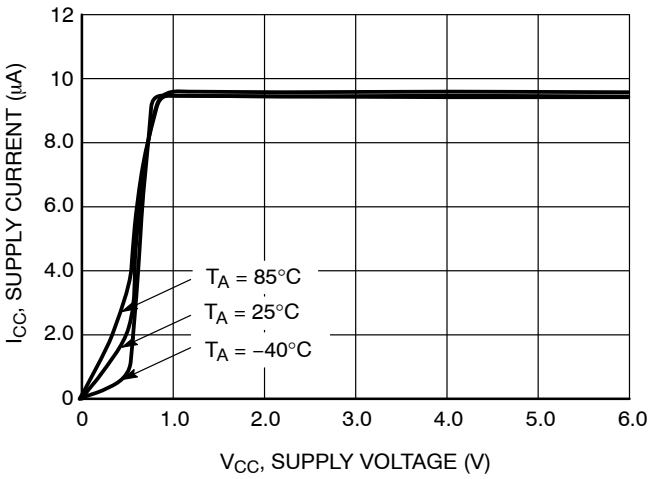

Figure 3. Supply Current versus Supply Voltage/Comparator

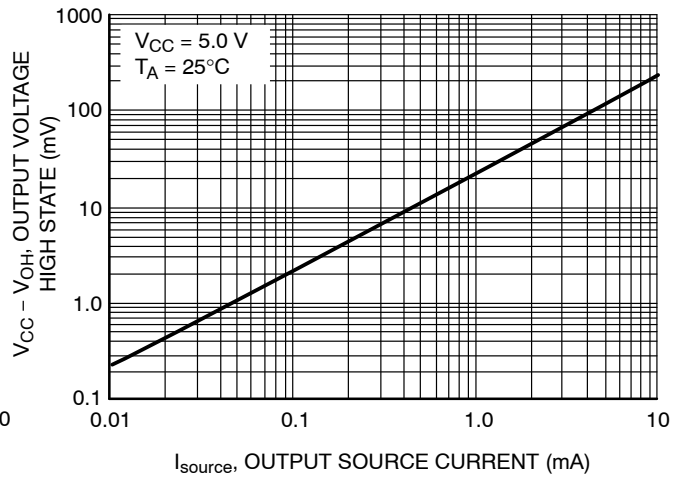

Figure 4. Output Voltage High State versus Output Source Current

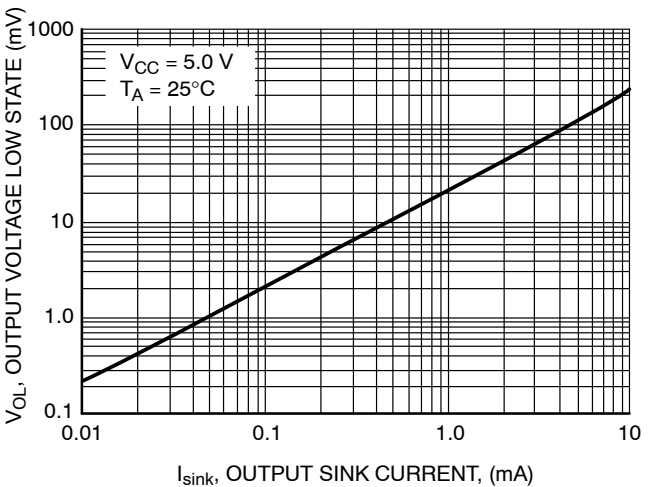

Figure 5. Output Voltage Low State versus Output Sink Current

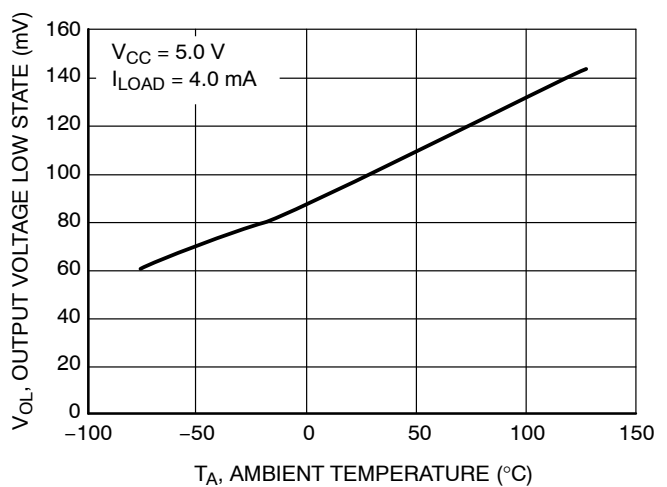

Figure 6. Output Voltage Low State versus Temperature

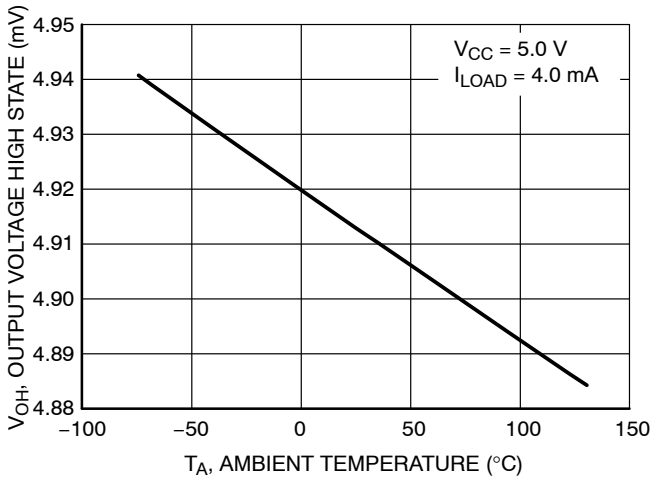

Figure 7. Output Voltage High State versus Temperature

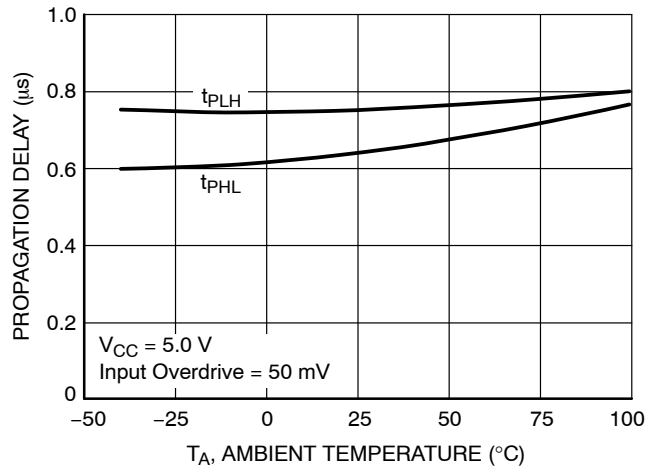

Figure 8. Propagation Delay versus Temperature

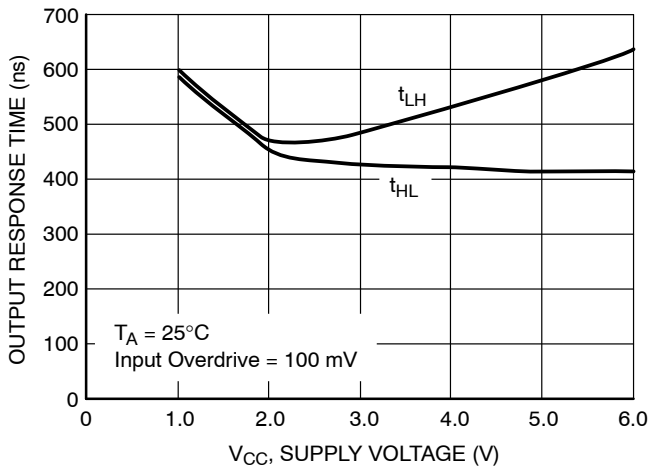

Figure 9. Output Response Time versus Supply Voltage

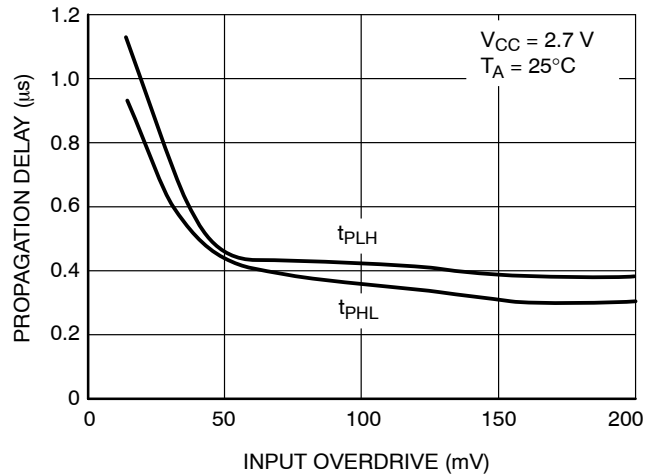

Figure 10. Propagation Delay versus Input Overdrive

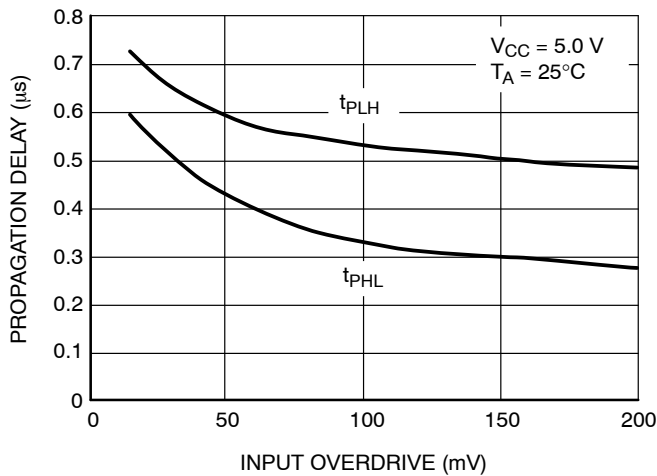

Figure 11. Propagation Delay versus Input Overdrive

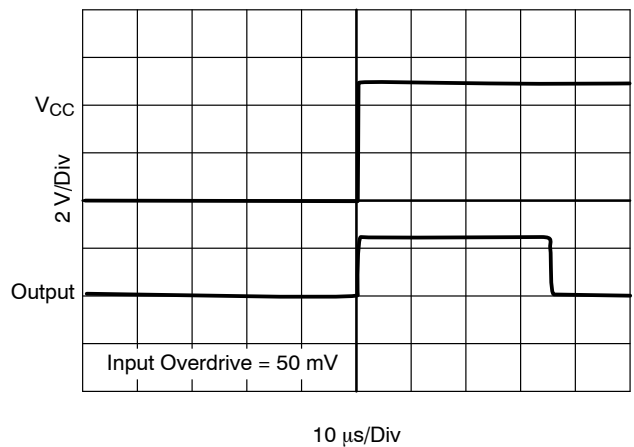

Figure 12. Powerup Delay

NCS2220A

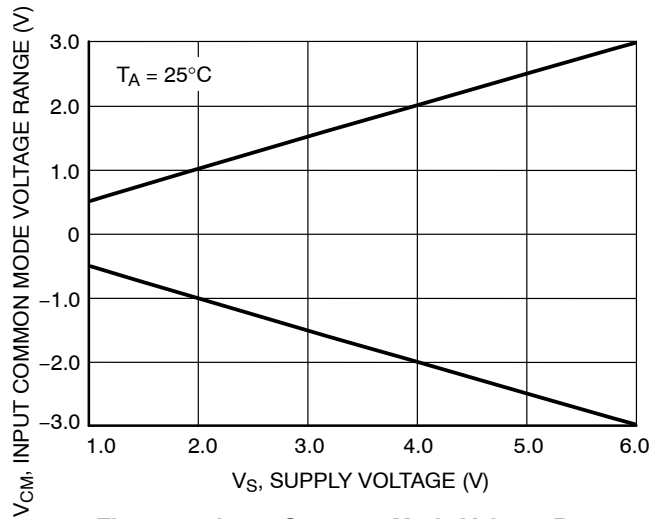

Figure 13. Input Common Mode Voltage Range versus Supply Voltage

OPERATING DESCRIPTION

The NCS2220A is an industry first sub-one volt, low power comparator. This device is designed for rail-to-rail input and output performance. This device consumes only 7.5 μ A/Comparator of supply current while achieving a typical propagation delay of 0.5 μ s at a 20 mV input overdrive. Figures 10 and 11 show propagation delay with various input overdrives. This comparator is guaranteed to operate at a low voltage of 0.85 V up to 6.0 V. This is accomplished by the use of a modified analog CMOS process that implements depletion MOSFET devices. The common-mode input voltage range extends 0.1 V beyond

the upper and lower rail without phase inversion or other adverse effects. This device has a typical internal hysteresis of ± 8.0 mV. This allows for greater noise immunity and clean output switching.

Output Stage

The NCS2220A has a complementary P and N Channel output stage that has capability of driving a rail-to-rail output swing with a load ranging up to 5.0 mA. It is designed such that shoot-through current is minimized while switching. This feature eliminates the need for bypass capacitors under most circumstances.

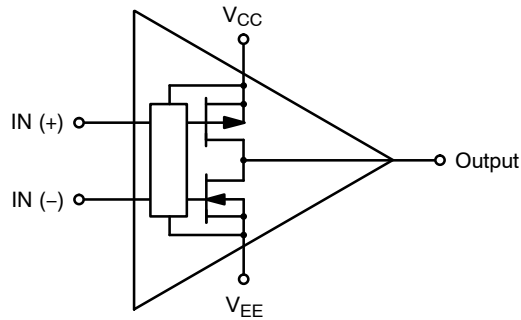
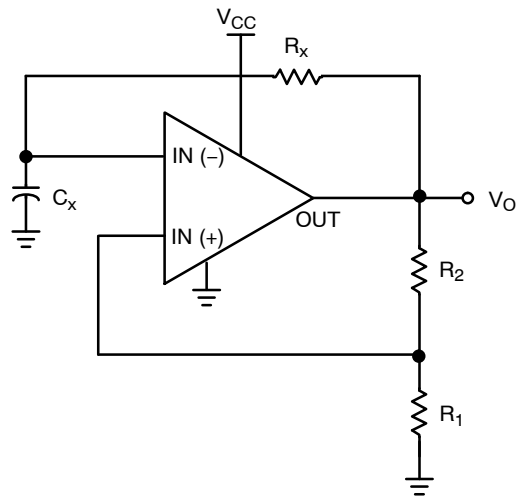

Figure 14. NCS2220A Complementary Output Configuration

NCS2220A



The oscillation frequency can be programmed as follows:

$$f = \frac{1}{T} = \frac{1}{2.2 R_x C_x}$$

Figure 15. Schmitt Trigger Oscillator

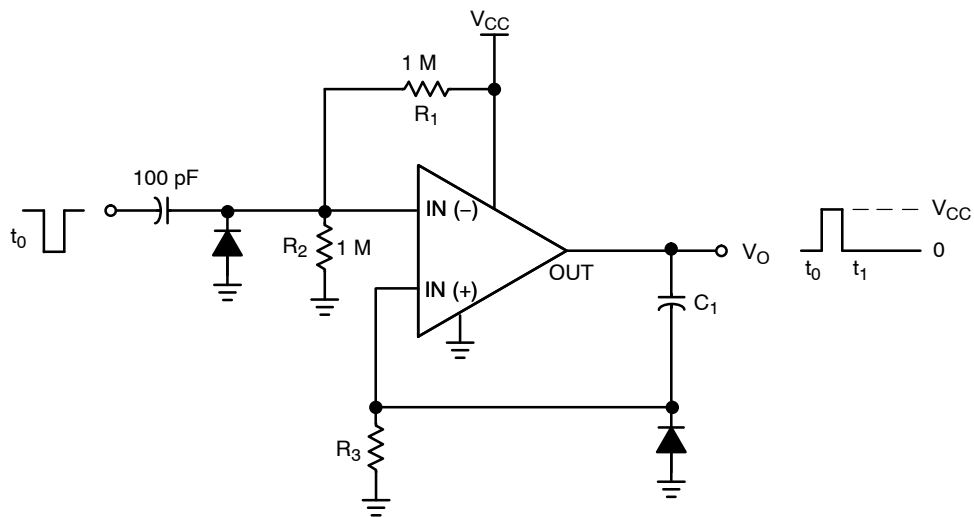

The resistor divider R_1 and R_2 can be used to set the magnitude of the input pulse. The pulse width is set by adjusting C_1 and R_3 .

Figure 16. One-Shot Multivibrator

NCS2220A

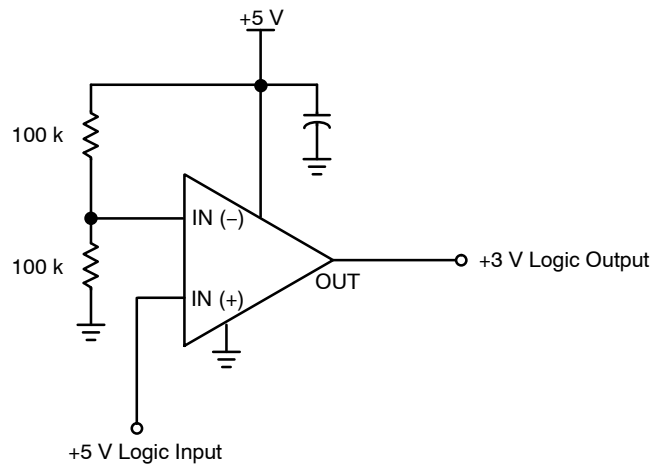

This circuit converts 5 V logic to 3 V logic. Using the NCS2220/A allows for full 5 V logic swing without creating overvoltage on the 3 V logic input.

Figure 17. Logic Level Translator

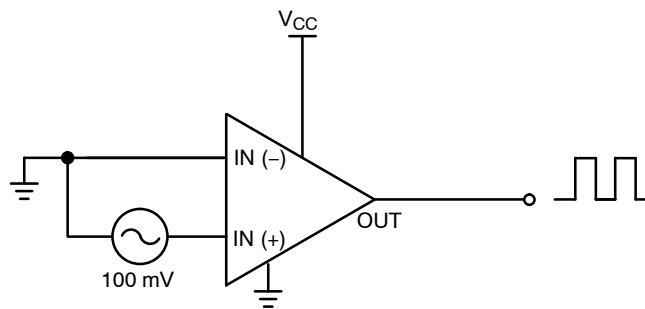
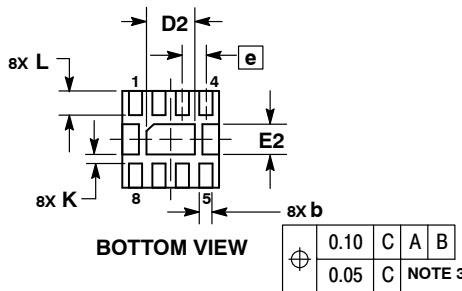
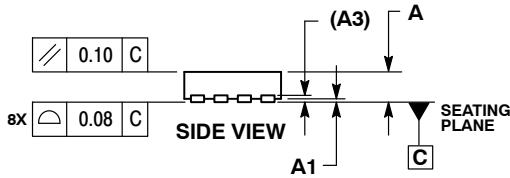
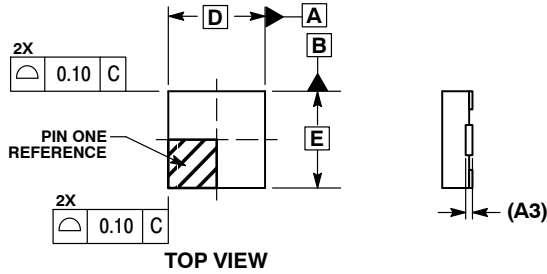

Figure 18. Zero-Crossing Detector

NCS2220A

PACKAGE DIMENSIONS

UDFN8, 1.6x1.6, 0.4P
CASE 517AC-01
ISSUE A



NOTES:

1. DIMENSIONING AND TOLERANCING PER ASME Y14.5M, 1994.
2. CONTROLLING DIMENSION: MILLIMETERS.
3. DIMENSION b APPLIES TO PLATED TERMINAL AND IS MEASURED BETWEEN 0.25 AND 0.30 mm FROM TERMINAL.
4. COPLANARITY APPLIES TO THE EXPOSED PAD AS WELL AS THE TERMINALS.
5. EXPOSED PADS CONNECTED TO DIE FLAG. USED AS TEST CONTACTS.

DIM	MILLIMETERS		
	MIN	NOM	MAX
A	0.45	0.50	0.55
A1	0.00	0.03	0.05
A3	0.127 REF		
b	0.15	0.20	0.25
D	1.60 BSC		
D2	0.70	0.80	0.90
E	1.60 BSC		
E2	0.40	0.50	0.60
e	0.40 BSC		
K	0.20	---	---
L	0.20	0.30	0.40

SOLDERING FOOTPRINT*

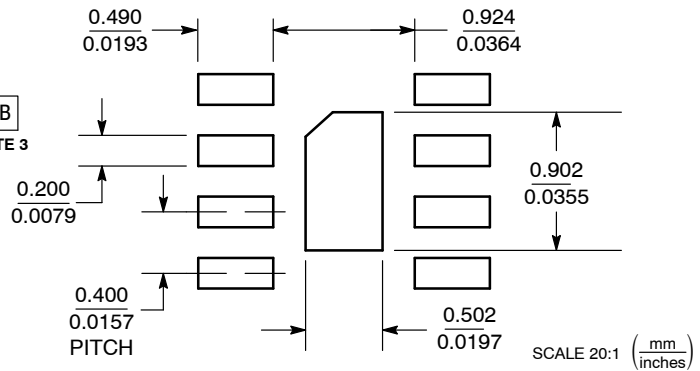

*For additional information on our Pb-Free strategy and soldering details, please download the ON Semiconductor Soldering and Mounting Techniques Reference Manual, SOLDERRM/D.

ON Semiconductor and  are registered trademarks of Semiconductor Components Industries, LLC (SCILLC). SCILLC owns the rights to a number of patents, trademarks, copyrights, trade secrets, and other intellectual property. A listing of SCILLC's product/patent coverage may be accessed at www.onsemi.com/site/pdf/Patent-Marking.pdf. SCILLC reserves the right to make changes without further notice to any products herein. SCILLC makes no warranty, representation or guarantee regarding the suitability of its products for any particular purpose, nor does SCILLC assume any liability arising out of the application or use of any product or circuit, and specifically disclaims any and all liability, including without limitation special, consequential or incidental damages. "Typical" parameters which may be provided in SCILLC data sheets and/or specifications can and do vary in different applications and actual performance may vary over time. All operating parameters, including "Typicals" must be validated for each customer application by customer's technical experts. SCILLC does not convey any license under its patent rights nor the rights of others. SCILLC products are not designed, intended, or authorized for use as components in systems intended for surgical implant into the body, or other applications intended to support or sustain life, or for any other application in which the failure of the SCILLC product could create a situation where personal injury or death may occur. Should Buyer purchase or use SCILLC products for any such unintended or unauthorized application, Buyer shall indemnify and hold SCILLC and its officers, employees, subsidiaries, affiliates, and distributors harmless against all claims, costs, damages, and expenses, and reasonable attorney fees arising out of, directly or indirectly, any claim of personal injury or death associated with such unintended or unauthorized use, even if such claim alleges that SCILLC was negligent regarding the design or manufacture of the part. SCILLC is an Equal Opportunity/Affirmative Action Employer. This literature is subject to all applicable copyright laws and is not for resale in any manner.

PUBLICATION ORDERING INFORMATION

LITERATURE FULFILLMENT:

Literature Distribution Center for ON Semiconductor
P.O. Box 5163, Denver, Colorado 80217 USA
Phone: 303-675-2175 or 800-344-3860 Toll Free USA/Canada
Fax: 303-675-2176 or 800-344-3867 Toll Free USA/Canada
Email: orderlit@onsemi.com

N. American Technical Support: 800-282-9855 Toll Free
USA/Canada
Europe, Middle East and Africa Technical Support:
Phone: 421 33 790 2910
Japan Customer Focus Center
Phone: 81-3-5817-1050

ON Semiconductor Website: www.onsemi.com

Order Literature: <http://www.onsemi.com/orderlit>

For additional information, please contact your local Sales Representative

Компания «Life Electronics» занимается поставками электронных компонентов импортного и отечественного производства от производителей и со складов крупных дистрибьюторов Европы, Америки и Азии.

С конца 2013 года компания активно расширяет линейку поставок компонентов по направлению коаксиальный кабель, кварцевые генераторы и конденсаторы (керамические, пленочные, электролитические), за счёт заключения дистрибьюторских договоров

Мы предлагаем:

- Конкурентоспособные цены и скидки постоянным клиентам.
- Специальные условия для постоянных клиентов.
- Подбор аналогов.
- Поставку компонентов в любых объемах, удовлетворяющих вашим потребностям.
- Приемлемые сроки поставки, возможна ускоренная поставка.
- Доставку товара в любую точку России и стран СНГ.
- Комплексную поставку.
- Работу по проектам и поставку образцов.
- Формирование склада под заказчика.
- Сертификаты соответствия на поставляемую продукцию (по желанию клиента).
- Тестирование поставляемой продукции.
- Поставку компонентов, требующих военную и космическую приемку.
- Входной контроль качества.
- Наличие сертификата ISO.

В составе нашей компании организован Конструкторский отдел, призванный помогать разработчикам, и инженерам.

Конструкторский отдел помогает осуществить:

- Регистрацию проекта у производителя компонентов.
- Техническую поддержку проекта.
- Защиту от снятия компонента с производства.
- Оценку стоимости проекта по компонентам.
- Изготовление тестовой платы монтаж и пусконаладочные работы.



Тел: +7 (812) 336 43 04 (многоканальный)
Email: org@lifeelectronics.ru