

## SM-8 COMPLEMENTARY CURRENT MIRROR

### DESCRIPTION

The ZDS1009 current mirror has been developed specifically for high side, current sense plus level translation applications and as such will find a broad application base including battery charge management, DC motor control and over current monitoring functions. It is of particular interest for current sense applications for feedback purposes in fast battery chargers for Li-Ion cell based systems.

The device functions by sensing the voltage developed across an external (user defined) high side current sense resistor, and by an arrangement of current mirrors refer this sensed voltage, with or without multiplication, to a low side referenced signal. This signal can then be used, for example, to close the control loop to a controller IC, for a DC-DC converter providing charge to a battery.

### FEATURES

- Excellent Temperature Tracking Characteristics
- Compact Cost Effective Solution
- Simplifies Circuit Implementation
- Broad application base from Single Cell Li-ion High Side Current sense chargers to Multi-cell Lead-Acid systems
- Only 4 Connections required

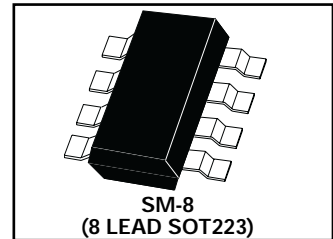

### SCHEMATIC DIAGRAM

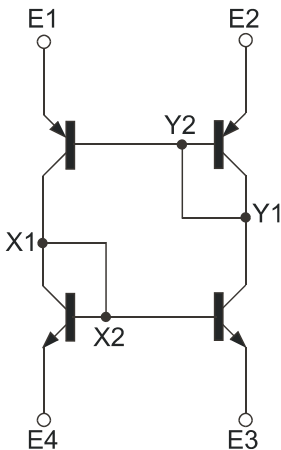

### CONNECTION DIAGRAM

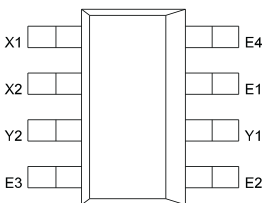

### TYPICAL APPLICATION CIRCUIT

$$V_{\text{sense}} = IR_2 \frac{R_4}{R_1}$$

For balance  $R_3=R_4$   
eg  
 $R_2=100\text{m}\Omega$   
 $R_1=R_3=R_4=100\Omega$   
 $V_{\text{sense}}$  sensitivity = 100mV/A

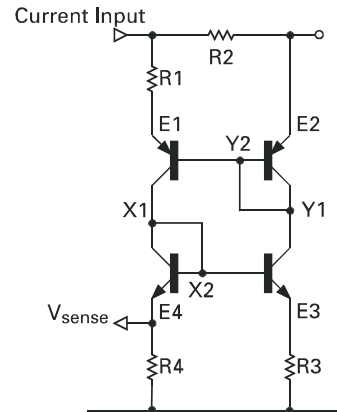

# ZDS1009

## ABSOLUTE MAXIMUM RATINGS.

PARAMETER	SYMBOL	VALUE	UNIT
Maximum Operating Voltage	$V_{y1-x1}$	120	V
Maximum Voltage (E1-E2,E3-E4)	$V_{E-E'}$	10	V
Peak Pulse Current	$I_M$	4	A
Continuous Current (E1-E4,E2-E3)	$I_C$	1	A
Total Power Dissipation at $T_{amb} = 25^{\circ}C^*$	$P_{tot}$	2	W
Operating and Storage Temperature Range	$T_j:T_{stg}$	-55 to +150	$^{\circ}C$

\* The power which can be dissipated assuming the device is mounted in a typical manner on a PCB with copper equal to 2 inches square.

## ELECTRICAL CHARACTERISTICS (at $T_{amb}=25^{\circ}C$ )

Parameter	Symbol	Min	Max	Unit	Conditions
Breakdown Voltage	$BV_{Y1-X1}$	120		V	$I_{Y1}=100\mu A$
Breakdown Voltage	$BV_{X1-E1}$	-30		V	$I_{X1}=-10mA$
Breakdown Voltage	$BV_{Y1-E3}$	30		V	$I_{Y1}=10mA$
Breakdown Voltage	$BV_{E1-Y1}$	-12		V	$I_{E1}=-100\mu A$
Breakdown Voltage	$BV_{E2-Y1}$	-6		V	$I_{E2}=-100\mu A$
Breakdown Voltage	$BV_{E3-X1}$	12		V	$I_{E3}=100\mu A$
Breakdown Voltage	$BV_{E4-X1}$	6		V	$I_{E4}=100\mu A$
Leakage	$I_{Y1}$		50	nA	$V_{Y1-X1}=100V$
Leakage	$I_{X1}$		-10	$\mu A$	$V_{X1-E1}=-30V, V_{Y1}=V_{E1}$
Leakage	$I_{Y1}$		10	$\mu A$	$V_{Y1-E3}=30V, V_{X1}=V_{E3}$
Leakage	$I_{E1}$		-100	nA	$V_{E1-Y1}=-8V$
Leakage	$I_{E2}$		-100	nA	$V_{E2-Y1}=-4V$
Leakage	$I_{E3}$		100	nA	$V_{E3-X1}=8V$
Leakage	$I_{E4}$		100	nA	$V_{E4-X1}=4V$
Input Voltage	$V_{Y1-E2}$	-1.45	-1.65	V	$I_{Y1}=-1A$
Input Voltage	$V_{Y1-E3}$	1.45	1.75	V	$I_{Y1}=1A, V_{X1}=V_{Y1}$
Input Voltage	$V_{X1-E1}$	-1.45	-1.75	V	$I_{X1}=-1A, V_{X1}=V_{Y1}$
Input Voltage	$V_{X1-E4}$	1.45	1.65	V	$I_{X1}=1A$
Transfer Characteristic	$V_{OUT}$	0.99	1.01	V	See Fig 1. $V_{CC}=5V$ $R1=R3=R4=100\Omega, V_{IN}=1V$
Transfer Characteristic	$V_{OUT}$	1		mV	See Fig 1. $V_{CC}=5V$ $R1=R3=R4=100\Omega, V_{IN}=5mV$
Output Zero-Offset Voltage	$V_{OFFSET}$		4	mV	See Fig 2. $V_{CC}=5V, R2<1\Omega$ $R1=R3=R4=100\Omega$

## TYPICAL CHARACTERISTICS

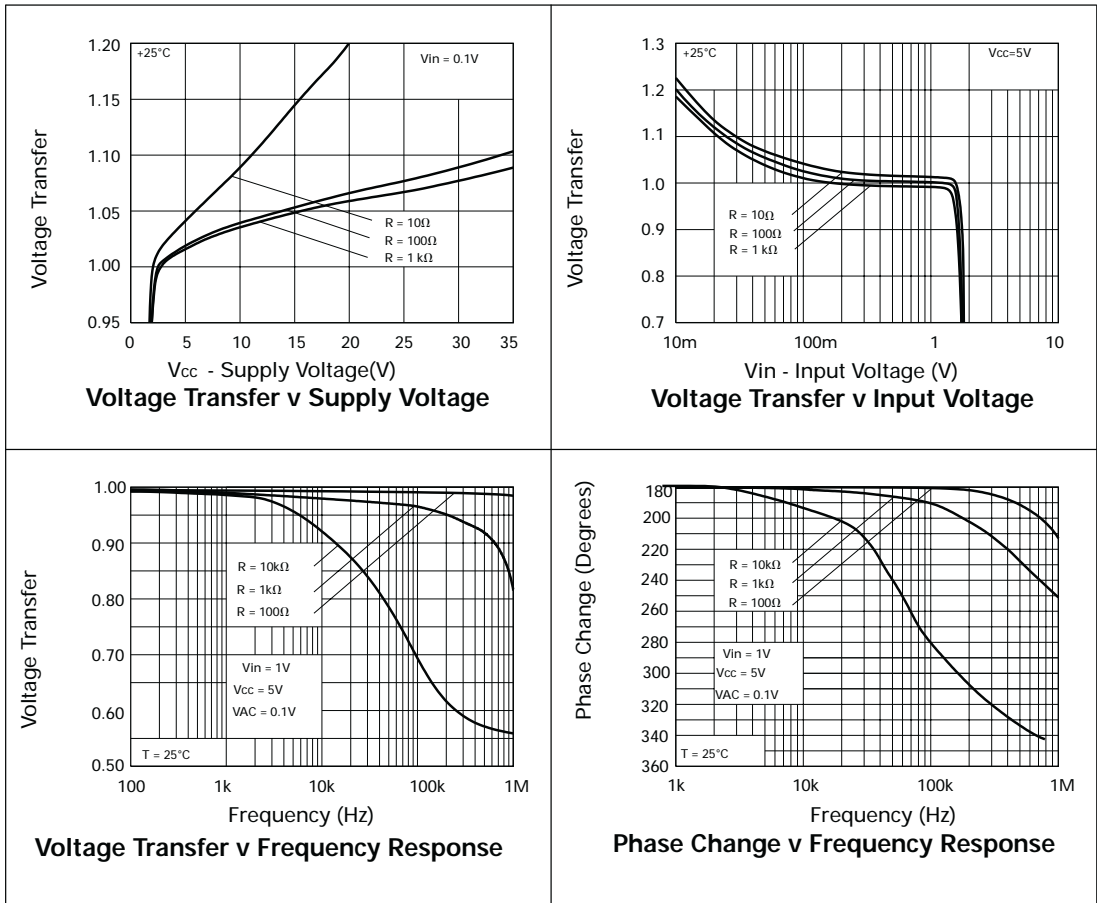

## TEST CIRCUITS

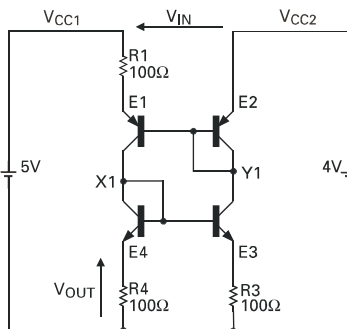

Figure 1  
Transfer Characteristic Test Circuit

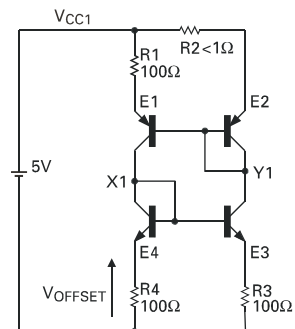
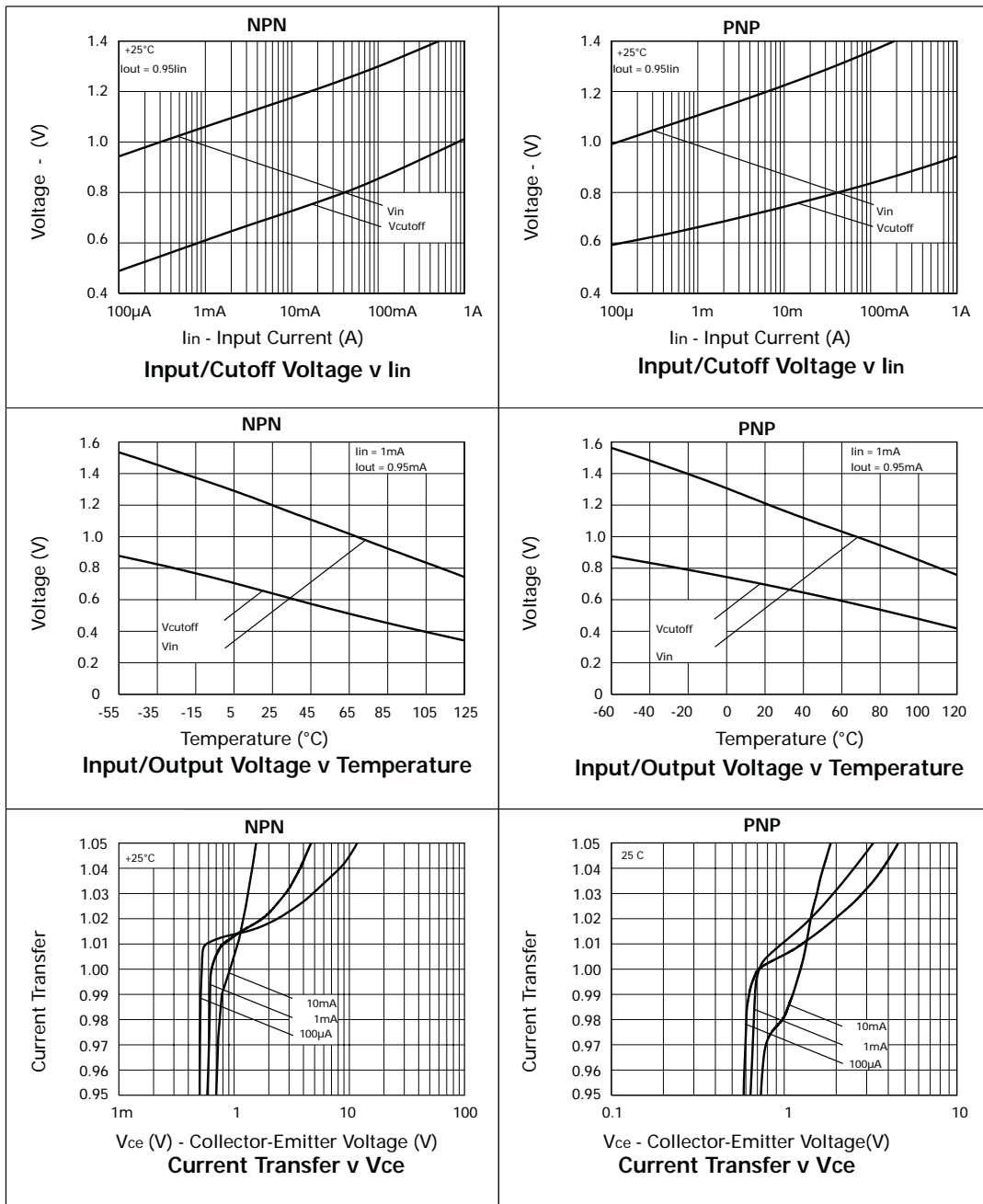
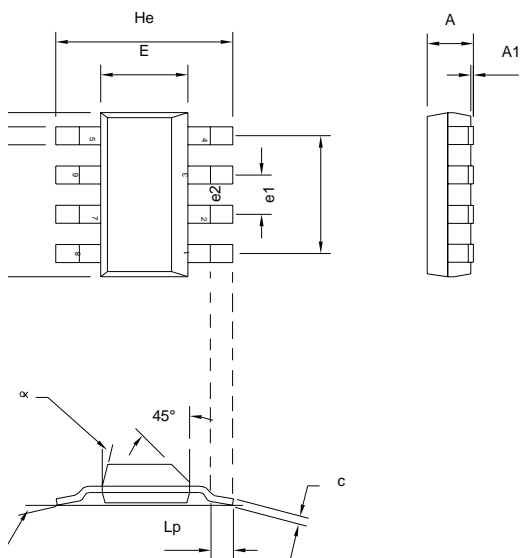

Figure 2  
Output Zero-Offset Voltage Test Circuit

## TYPICAL CHARACTERISTICS



## PACKAGE DIMENSIONS



DIM	Millimetres			Inches		
	Min	Typ	Max	Min	Typ	Max
A	-	-	1.7	-	-	0.067
A1	0.02	-	0.1	0.0008	-	0.004
b	-	0.7	-	-	0.028	-
c	0.24	-	0.32	0.009	-	0.013
D	6.3	-	6.7	0.248	-	0.264
E	3.3	-	3.7	0.130	-	0.145
e1	-	4.59	-	-	0.180	-
e2	-	1.53	-	-	0.060	-
He	6.7	-	7.3	0.264	-	0.287
Lp	0.9	-	-	0.035	-	-
$\alpha$	-	-	15°	-	-	15°
$\beta$	-	10°	-	-	10°	-

## ORDERING INFORMATION

DEVICE	PARTMARKING
ZDS1009	S1009



Zetex plc.  
Fields New Road, Chadderton, Oldham, OL9 8NP, United Kingdom.  
Telephone: (44)161 622 4422 (Sales), (44)161 622 4444 (General Enquiries)  
Fax: (44)161 622 4420

Zetex GmbH  
Streitfeldstraße 19  
D-81673 München  
Germany  
Telefon: (49) 89 45 49 49 0  
Fax: (49) 89 45 49 49 49

Zetex Inc.  
47 Mall Drive, Unit 4  
Commack NY 11725  
USA  
Telephone: (631) 543-7100  
Fax: (631) 864-7630

Zetex (Asia) Ltd.  
3510 Metroplaza, Tower 2  
Hing Fong Road,  
Kwai Fong, Hong Kong  
Telephone: (852) 26100 611  
Fax: (852) 24250 494

These are supported by  
agents and distributors in  
major countries world-wide  
© Zetex plc 2000

Internet <http://www.zetex.com>

This publication is issued to provide outline information only which (unless agreed by the Company in writing) may not be used, applied or reproduced for any purpose or form part of any order or contract or be regarded as a representation relating to the products or services concerned. The Company reserves the right to alter without notice the specification, design, price or conditions of supply of any product or service.

Компания «Life Electronics» занимается поставками электронных компонентов импортного и отечественного производства от производителей и со складов крупных дистрибьюторов Европы, Америки и Азии.

С конца 2013 года компания активно расширяет линейку поставок компонентов по направлению коаксиальный кабель, кварцевые генераторы и конденсаторы (керамические, пленочные, электролитические), за счёт заключения дистрибьюторских договоров

Мы предлагаем:

- Конкурентоспособные цены и скидки постоянным клиентам.
- Специальные условия для постоянных клиентов.
- Подбор аналогов.
- Поставку компонентов в любых объемах, удовлетворяющих вашим потребностям.
- Приемлемые сроки поставки, возможна ускоренная поставка.
- Доставку товара в любую точку России и стран СНГ.
- Комплексную поставку.
- Работу по проектам и поставку образцов.
- Формирование склада под заказчика.
- Сертификаты соответствия на поставляемую продукцию (по желанию клиента).
- Тестирование поставляемой продукции.
- Поставку компонентов, требующих военную и космическую приемку.
- Входной контроль качества.
- Наличие сертификата ISO.

В составе нашей компании организован Конструкторский отдел, призванный помогать разработчикам, и инженерам.

Конструкторский отдел помогает осуществить:

- Регистрацию проекта у производителя компонентов.
- Техническую поддержку проекта.
- Защиту от снятия компонента с производства.
- Оценку стоимости проекта по компонентам.
- Изготовление тестовой платы монтаж и пусконаладочные работы.



Тел: +7 (812) 336 43 04 (многоканальный)

Email: [org@lifeelectronics.ru](mailto:org@lifeelectronics.ru)