

# Common-mode Suppression Chokes

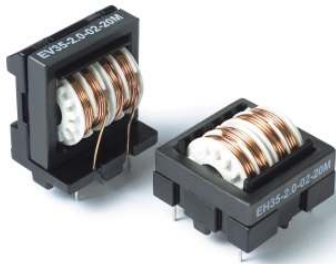

- | Rated currents up to 5 A
- | Broadband attenuation characteristics
- | Low magnetic leakage flux
- | UL rated materials
- | RoHS compliant



## Technical specifications

<b>Maximum continuous operating voltage</b>	250 VAC @ 50 °C
<b>Operating frequency</b>	dc to 400Hz @ 50 °C
<b>Rated currents</b>	0.3 to 5 A
<b>Overcurrent</b>	1.5x Inominal for 1 minute, once per hour
<b>High potential test voltage winding-to-winding @ 25°C</b>	3000 VAC, 60 sec, guaranteed 2000 V, 50 Hz, 2 sec, factory test
<b>Temperature range (operation and storage)</b>	-25 °C to +100 °C (25/100/21)
<b>Flammability corresponding to</b>	UL 94 V-0
<b>Measuring frequency</b>	10 kHz; 5 mA < 16 µH; 500 µA > 16 µH < 160 µH; 50 µA > 160 µH > 16 mH; 50 mV > 16 mH < 160 mH Inductance tolerance ±30%
<b>Resistance</b>	Tolerance max. ±15% @ 25 °C; ≤ 20 mΩ, 1 A; > 20 mΩ ≤ 200 mΩ, 100 mA; > 200 mΩ ≤ 2 V, 10 mA
<b>Electrical characteristics</b>	@ 25 °C ±2 °C

## Approvals

### ROHS

Common-mode suppression chokes are mainly used to filter noise on AC power lines. Noise on commercial power lines could enter the equipment and disturb the proper function. Noise generated by the equipment for example from switch mode power supplies need to be filtered and the spread of such generated noise need to be suppressed. Common-mode suppression chokes together with line bypass capacitors building an AC EMI suppression filter device.

## Features and benefits

- | Rated currents up to 5A
- | Compact and light weight
- | Low magnetic leakage flux
- | Sectional winding
- | Standard foot print
- | Broad range of available inductances and current ratings
- | Custom-specific versions
- | Schaffner offers you also EMI measurement service to verify that your design will pass the required safety standards

## Typical applications

- | Input filters for switch mode power supplies
- | Filters to reduce leaking noise
- | TVs, VCRs, multimedia and audio equipment
- | Office automation, communications and other electronic devices
- | Electric ballast
- | AC/AC converters

## Typical electrical schematic

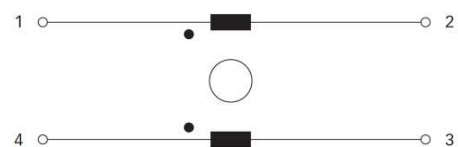

### Choke selection table

EV choke	EH choke	L nominal (±30%) [mH]	DC resistance R [mΩ]	Rated current I (50 °C) [A]	Weight [g]
EV 20-0.3-02-33M	EH 20-0.3-02-33M	33	1780	0.3	10
EV 20-0.5-02-18M	EH 20-0.5-02-18M	18	725	0.5	10
EV 20-0.8-02-5M6	EH 20-0.8-02-5M6	5.6	245	0.8	10
EV 20-1.0-02-3M9	EH 20-1.0-02-3M9	3.9	168	1.0	10
EV 20-1.2-02-3M3	EH 20-1.2-02-3M3	3.3	127	1.2	10
EV 20-1.5-02-1M8	EH 20-1.5-02-1M8	1.8	72	1.5	10
EV 20-2.0-02-0M8	EH 20-2.0-02-0M8	0.82	38	2.0	10
EV 24-0.5-02-44M	EH 24-0.5-02-44M	44	1250	0.5	18
EV 24-0.8-02-18M	EH 24-0.8-02-18M	18	438	0.8	18
EV 24-1.0-02-10M	EH 24-1.0-02-10M	10	244	1.0	18
EV 24-1.5-02-4M5	EH 24-1.5-02-4M5	4.5	116	1.5	18
EV 24-2.0-02-2M5	EH 24-2.0-02-2M5	2.5	62	2.0	18
EV 24-3.0-02-1M2	EH 24-3.0-02-1M2	1.2	29	3.0	18
EV 24-4.0-02-0M5	EH 24-4.0-02-0M5	0.5	16	4.0	18
EV 28-1.0-02-36M	EH 28-1.0-02-36M	36	591	1.0	31
EV 28-1.5-02-20M	EH 28-1.5-02-20M	20	282	1.5	31
EV 28-2.0-02-11M	EH 28-2.0-02-11M	11	162	2.0	31
EV 28-3.0-02-5M0	EH 28-3.0-02-5M0	5	79	3.0	31
EV 28-4.0-02-2M3	EH 28-4.0-02-2M3	2.3	40	4.0	31
EV 28-5.0-02-1M1	EH 28-5.0-02-1M1	1.1	27	5.0	31
EV 35-1.0-02-90M	EH 35-1.0-02-90M	90	628	1.0	70
EV 35-2.0-02-20M	EH 35-2.0-02-20M	20	150	2.0	70
EV 35-3.0-02-10M	EH 35-3.0-02-10M	10	72	3.0	70
EV 35-4.0-02-5M0	EH 35-4.0-02-5M0	5	53	4.0	70
EV 35-5.0-02-3M6	EH 35-5.0-02-3M6	3.6	33	5.0	70

All wires rated 130 °C or higher.

### Typical choke attenuation

Per CISPR 17; 50 Ω/50 Ω asym

EV/EH 20 types

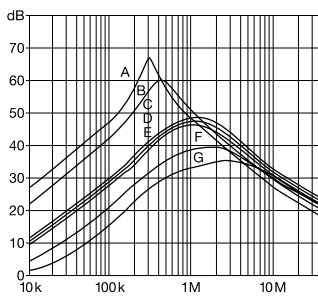

- A = 33mH
- B = 18mH
- C = 5.6mH
- D = 3.9mH
- E = 3.3mH
- F = 1.8mH
- G = 0.8mH

EV/EH 24 types

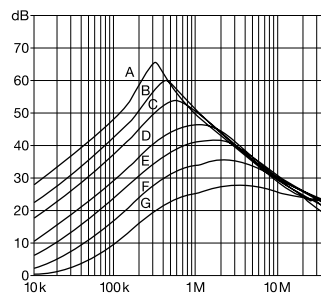

- A = 44mH
- B = 18mH
- C = 10mH
- D = 5.5mH
- E = 2.5mH
- F = 1.2mH
- G = 0.5mH

EV/EH 28 types

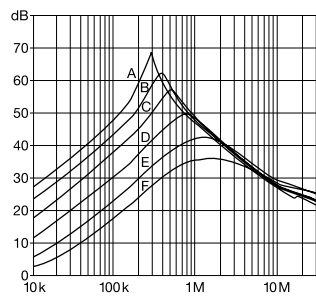

- A = 36mH
- B = 20mH
- C = 11mH
- D = 5mH
- E = 2.3mH
- F = 1.1mH

EV/EH 35 types

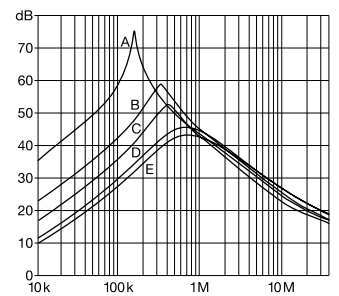

- A = 90mH
- B = 20mH
- C = 10mH
- D = 5mH
- E = 3.6mH

**Mechanical data**

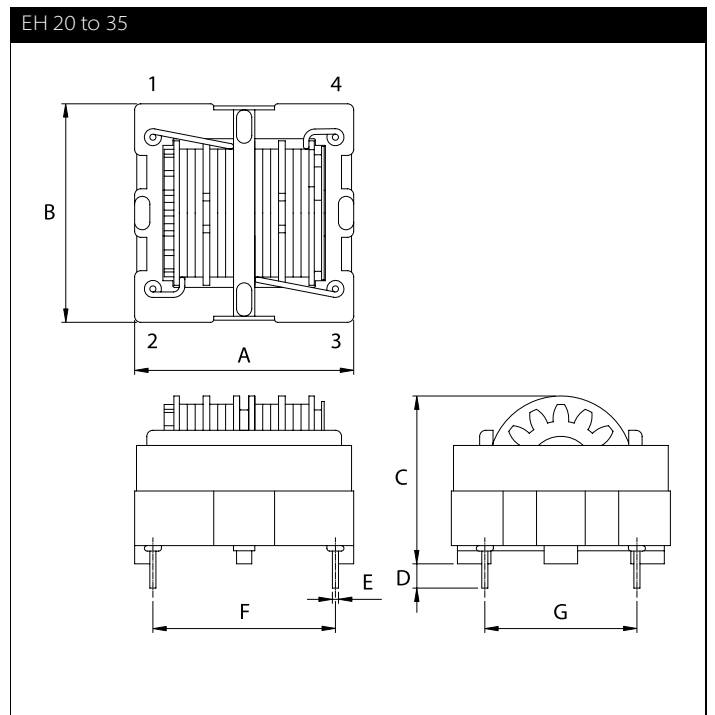
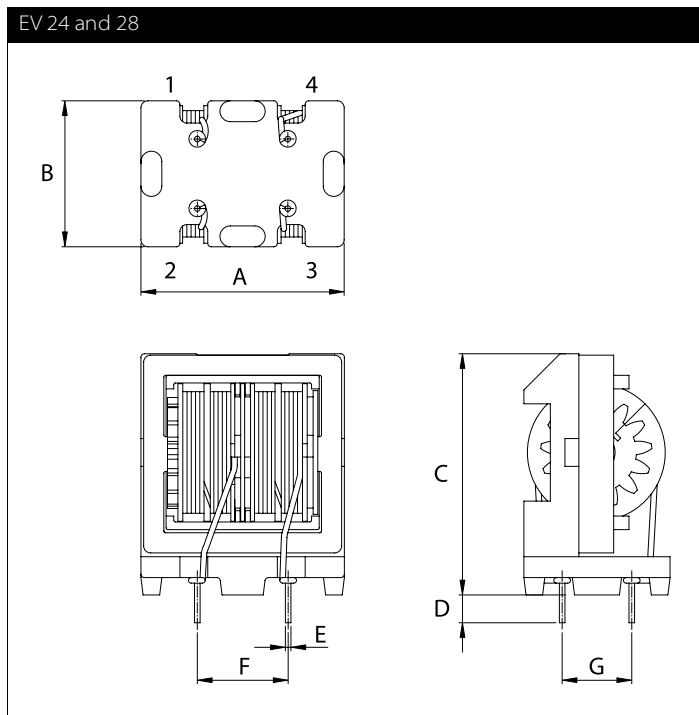
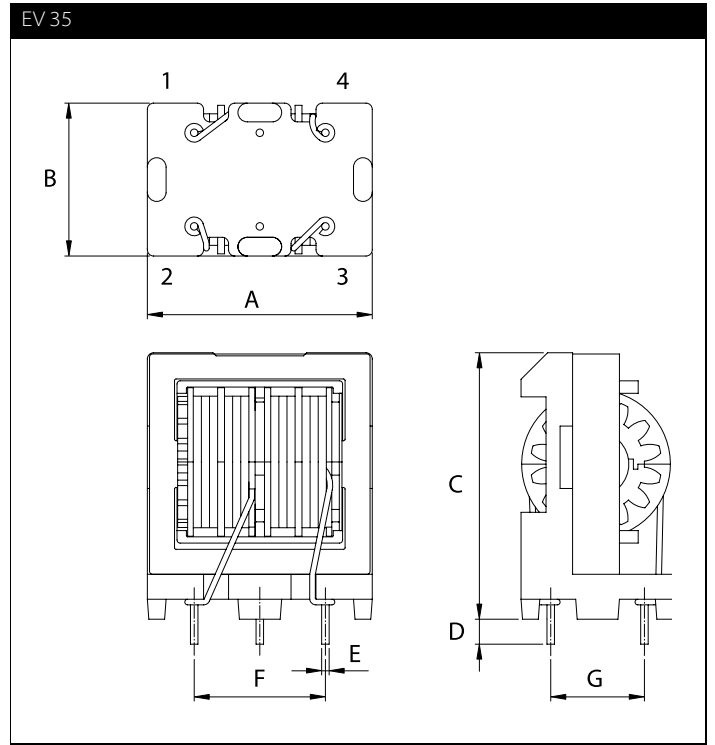
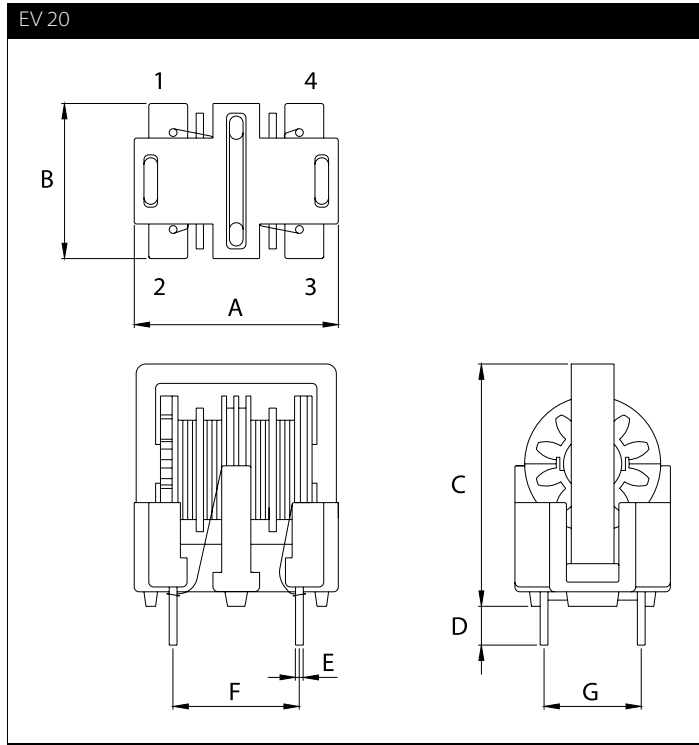

## Dimensions

	EV 20	EV 24	EV 28	EV 35	EH 20	EH 24	EH 28	EH35	Tolerances
<b>A</b>	21	24.6	29.2	36	21	24	28	36	±1
<b>B</b>	16	17.4	21	24.5	21	24	28	36	±1
<b>C</b>	25*	29.1	34.7	42.7	17.8	20	22.9	27.7	±1
<b>D</b>	4	4	4	4	4	4	4	4	±1
<b>E</b>	Ø0.8	Ø0.8	Ø0.8	Ø1.2	Ø0.8	Ø0.8	Ø0.8	Ø1.0	±0.1
<b>F</b>	13	13	13	21	13	21	24	30	±0.5
<b>G</b>	10	10	10	15	10	15	20	25	±0.5

All dimensions in mm; 1 inch = 25.4 mm

\*Tolerance is +1/-2 mm

Please visit [www.schaffner.com](http://www.schaffner.com) to find more details on filter connectors.



## Headquarters, global innovation and development center

### Switzerland

#### Schaffner Group

Nordstrasse 11  
4542 Luterbach  
T +41 32 6816 626  
F +41 32 6816 630  
[info@schaffner.com](mailto:info@schaffner.com)  
<http://www.schaffner.com>



## Sales and application centers

### China

#### Schaffner EMC Ltd. Shanghai

T20-3, No 565 Chuangye Road  
Pudong New Area  
201201 Shanghai  
T +86 21 3813 9500  
F +86 21 3813 9501 / 02  
[cschina@schaffner.com](mailto:cschina@schaffner.com)  
<http://www.schaffner.com.cn/>

### Finland

#### Schaffner Oy

Sauvonrinne 19 H  
08500 Lohja  
T +358 19 35 72 71  
[finlandsales@schaffner.com](mailto:finlandsales@schaffner.com)

### France

#### Schaffner EMC S.A.S.

112, Quai de Bezons  
Boîte postale 133  
95103 Argenteuil  
T +33 1 34 34 30 60  
F +33 1 39 47 02 28  
[francesales@schaffner.com](mailto:francesales@schaffner.com)

### Germany

#### Schaffner Deutschland GmbH

Schoemperlenstrasse 12B  
76185 Karlsruhe  
T +49 721 56910  
F +49 721 569110  
[germanysales@schaffner.com](mailto:germanysales@schaffner.com)

### Italy

#### Schaffner EMC S.r.l.

Via Galileo Galilei 47  
20092 Cinisello Balsamo (MI)  
T +39 02 66 04 30 45/47  
F +39 02 61 23 943  
[italysales@schaffner.com](mailto:italysales@schaffner.com)

### Japan

#### Schaffner EMC K.K.

1-32-12, Kamiyama, Setagaya-ku  
7F Mitsui-seimei Sangenjaya Bldg.  
154-0011 Tokyo  
T +81 3 5712 3650  
F +81 3 5712 3651  
[japansales@schaffner.com](mailto:japansales@schaffner.com)  
<http://www.schaffner.jp>

### Singapore

#### Schaffner EMC Pte Ltd.

Blk 3015A Ubi Road 1  
05-09 Kampong Ubi Industrial Estate  
408705 Singapore  
T +65 6377 3283  
F +65 6377 3281  
[singaporesales@schaffner.com](mailto:singaporesales@schaffner.com)

### Spain

#### Schaffner EMC España

Calle Caléndula 93  
Miniparc III, Edificio E  
El Soto de la Moraleja  
Alcobendas  
28109 Madrid  
T +34 618 176 133  
[spainsales@schaffner.com](mailto:spainsales@schaffner.com)

### Sweden

#### Schaffner EMC AB

Turebergstorg 1, 6  
19147 Sollentuna  
T +46 8 5792 1121 / 22  
F +46 8 92 96 90  
[swedensales@schaffner.com](mailto:swedensales@schaffner.com)

### Switzerland

#### Schaffner EMV AG

Nordstrasse 11  
4542 Luterbach  
T +41 32 6816 626  
F +41 32 6816 641  
[sales@schaffner.ch](mailto:sales@schaffner.ch)

### Taiwan R.O.C.

#### Schaffner EMV Ltd.

6 Floor, No. 413  
Rui Guang Road  
114 Neihu District Taipei City  
T +886 2 87525050  
F +886 2 87518086  
[taiwansales@schaffner.com](mailto:taiwansales@schaffner.com)

### Thailand

#### Schaffner EMC Co. Ltd.

Northern Region Industrial Estate  
67 Moo 4 Tambon Ban Klang  
Amphur Muang P.O. Box 14  
51000 Lamphun  
T +66 53 58 11 04  
F +66 53 58 10 19  
[thailandsales@schaffner.com](mailto:thailandsales@schaffner.com)

### UK

#### Schaffner Ltd.

5 Ashville Way  
Molly Millars Lane  
Wokingham  
RG41 2PL Berkshire  
T +44 118 9770070  
F +44 118 9792969  
[uksales@schaffner.com](mailto:uksales@schaffner.com)  
<http://www.schaffner.uk.com>

### USA

#### Schaffner EMC Inc.

52 Mayfield Avenue  
08837 Edison, New Jersey  
T +1 800 367 5566  
T +1 732 225 9533  
F +1 732 225 4789  
[usasales@schaffner.com](mailto:usasales@schaffner.com)  
<http://www.schaffner.com/us>

#### Schaffner MTC LLC

6722 Thirlane Road  
24019 Roanoke, Virginia  
T +1 276 228 7943  
F +1 276 228 7953  
<http://www.schaffner-mtc.com>

#### Schaffner Trencos LLC

2550 Brookpark Road  
44134 Cleveland, Ohio  
T +1 216 741 5282  
F +1 216 741 4860  
[www.schaffner-trencos.com](http://www.schaffner-trencos.com)

To find your local partner within Schaffner's global network: [www.schaffner.com](http://www.schaffner.com)

© 2014 Schaffner Group

The content of this document has been carefully checked and understood. However, neither Schaffner nor its subsidiaries assume any liability whatsoever for any errors or inaccuracies of this document and the consequences thereof. Published specifications are subject to change without notice. Product suitability for any area of application must ultimately be determined by the customer. In all cases, products must never be operated outside their published specifications. Schaffner does not guarantee the availability of all published products. This disclaimer shall be governed by substantive Swiss law and resulting disputes shall be settled by the courts at the place of business of Schaffner Holding AG. Latest publications and a complete disclaimer can be downloaded from the Schaffner website. All trademarks recognized.

Компания «Life Electronics» занимается поставками электронных компонентов импортного и отечественного производства от производителей и со складов крупных дистрибьюторов Европы, Америки и Азии.

С конца 2013 года компания активно расширяет линейку поставок компонентов по направлению коаксиальный кабель, кварцевые генераторы и конденсаторы (керамические, пленочные, электролитические), за счёт заключения дистрибьюторских договоров

Мы предлагаем:

- Конкурентоспособные цены и скидки постоянным клиентам.
- Специальные условия для постоянных клиентов.
- Подбор аналогов.
- Поставку компонентов в любых объемах, удовлетворяющих вашим потребностям.
- Приемлемые сроки поставки, возможна ускоренная поставка.
- Доставку товара в любую точку России и стран СНГ.
- Комплексную поставку.
- Работу по проектам и поставку образцов.
- Формирование склада под заказчика.
- Сертификаты соответствия на поставляемую продукцию (по желанию клиента).
- Тестирование поставляемой продукции.
- Поставку компонентов, требующих военную и космическую приемку.
- Входной контроль качества.
- Наличие сертификата ISO.

В составе нашей компании организован Конструкторский отдел, призванный помогать разработчикам, и инженерам.

Конструкторский отдел помогает осуществить:

- Регистрацию проекта у производителя компонентов.
- Техническую поддержку проекта.
- Защиту от снятия компонента с производства.
- Оценку стоимости проекта по компонентам.
- Изготовление тестовой платы монтаж и пусконаладочные работы.



Тел: +7 (812) 336 43 04 (многоканальный)

Email: [org@lifeelectronics.ru](mailto:org@lifeelectronics.ru)