

# LC717A10ARGPGEVB

## Capacitance-Digital-Converter LSI for Electrostatic Capacitive Touch Sensors Evaluation Board User's Manual



ON Semiconductor®

<http://onsemi.com>

### EVAL BOARD USER'S MANUAL

#### Introduction

This manual contains configuration, usage and main specifications regarding Electrostatic Capacitive Touch Sensor Evaluation Board (LC717A10ARGPGEVB).

For the latest edition of this manual, please refer to ON Semiconductor homepage. (<http://www.onsemi.com>)

#### Product Outline

This product is a board that can be used to evaluate LSI "LC717A10AR". Due to the fact it is 600 mil wide DIP shape, it is easy to use. It can be set up to evaluate any given touch switch pattern.

In order for evaluation, it is necessary to obtain an USB-to-Serial conversion module for SPI communication, a PC to evaluate software, and a board with a designed switch pattern.

- Electrostatic Capacitive Touch Sensor Evaluation Board LC717A10ARGPGEVB
- Accessory Connector Pin (8pin)

### EVALUATION BOARD

#### LC717A10ARGPGEVB Evaluation Board Outline

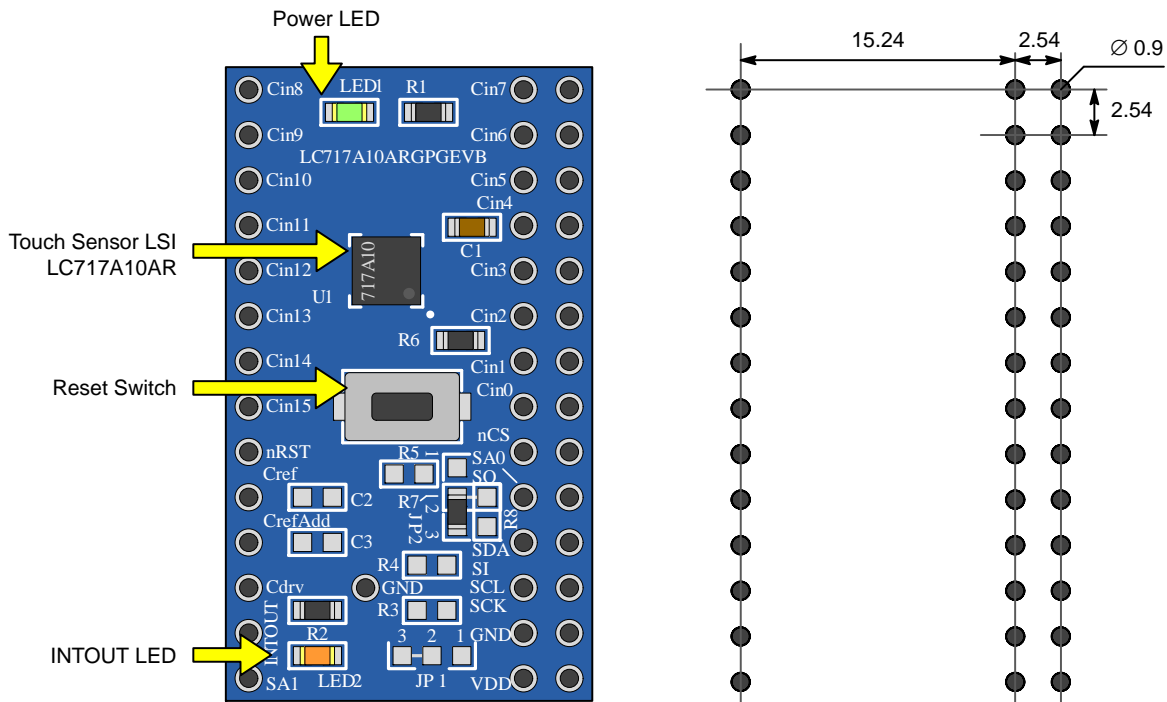

Figure 1. Configuration of LC717A10ARGPGEVB

# LC717A10ARGPGEVB

- Touch Sensor LSI:**  
 Electrostatic Capacitive Touch Sensor LSI  
 LC717A10AR
- Power LED:**  
 When a power is supplied, it turns on. Power supply voltage is 2.6 to 5.5 V.
- Reset Switch:**  
 This is used to RESET Touch Sensor LSI. Use this switch if any abnormality is encountered during operation.
- INTOUT LED:**  
 When the INTOUT signal outputs, it turns on.

## Evaluation Board Specifications

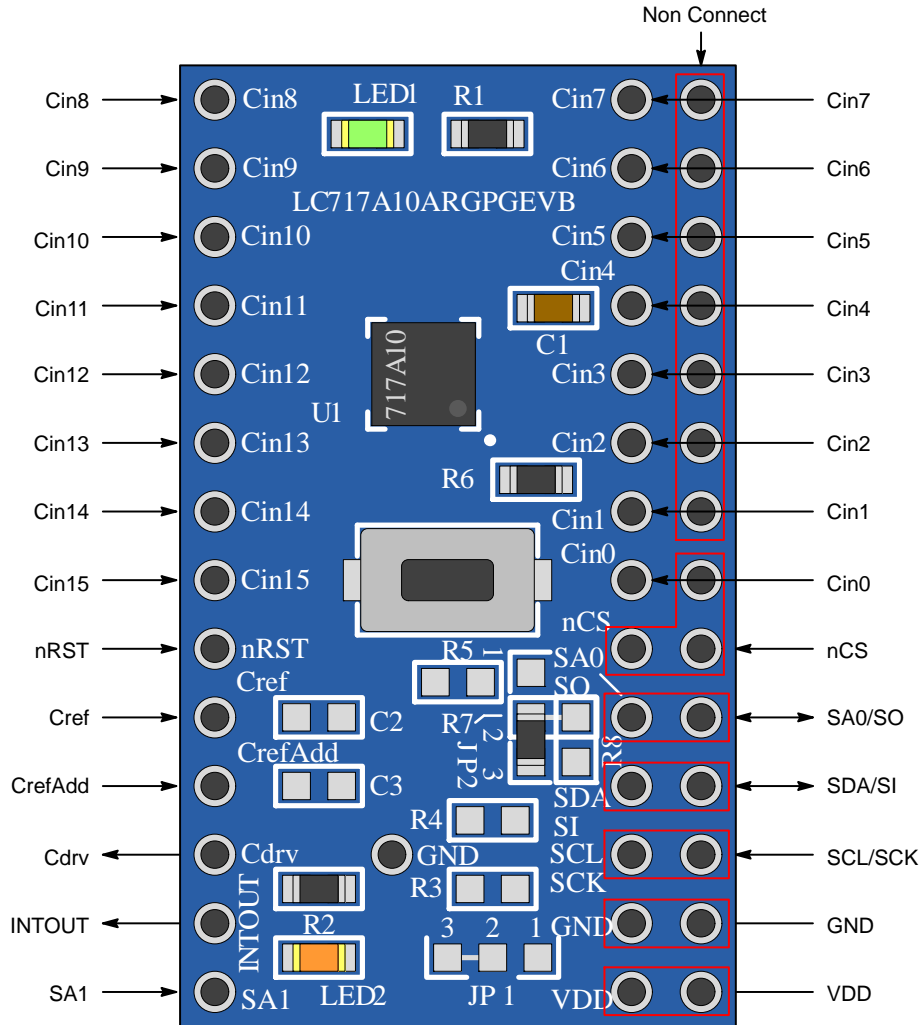

Figure 2. Terminal Pin Layout

# LC717A10ARGPGEVB

**Table 1. SIGNAL PIN FUNCTIONS**

Pin Name	I/O	Pin Functions
Cin0	I/O	Capacitance Sensor Input
Cin1	I/O	Capacitance Sensor Input
Cin2	I/O	Capacitance Sensor Input
Cin3	I/O	Capacitance Sensor Input
Cin4	I/O	Capacitance Sensor Input
Cin5	I/O	Capacitance Sensor Input
Cin6	I/O	Capacitance Sensor Input
Cin7	I/O	Capacitance Sensor Input
Cin8	I/O	Capacitance Sensor Input
Cin9	I/O	Capacitance Sensor Input
Cin10	I/O	Capacitance Sensor Input
Cin11	I/O	Capacitance Sensor Input
Cin12	I/O	Capacitance Sensor Input
Cin13	I/O	Capacitance Sensor Input
Cin14	I/O	Capacitance Sensor Input
Cin15	I/O	Capacitance Sensor Input
Cref	I/O	Reference Capacitance Input
CrefAdd	I/O	Reference Capacitance Input for Addition
Cdrv	O	Output for Capacitance Sensors Drive
INTOUT	O	Interrupt Output
SCL/SCK	I	Clock Input (I <sup>2</sup> C)/Clock Input (SPI)
nCS	I	Interface Selection/Chip Select Inverting Input (SPI)
nRST	I	External Reset Signal Inverting Input (2.2 kΩ Pull-up, with Switch)
SA1	I	Slave Address Selection (I <sup>2</sup> C)
SDA/SI	I/O	Data Input and Output (I <sup>2</sup> C)/Data Input (SPI)
SA0/SO	I/O	Slave Address Selection (I <sup>2</sup> C)/Data Output (SPI) (JP2 100 kΩ Pull-down)
VDD	–	Power Supply (2.6 V to 5.5 V). It is Connected to V <sub>DD</sub> of LC717A10AR
GND	–	Ground (Earth). It is Connected to V <sub>SS</sub> of LC717A10AR

**Table 2. MAIN SPECIFICATIONS**

Parameter	Conditions	Remarks
Board Size	35.56 × 20.32 (mm)	
Board Material	Glass Epoxy (FR4)	Copper Foil: 35 μm, Thickness: 1.6 mm, 2-layer Board
Supply Voltage	2.6 to 5.5 V	
Capacitance Touch Sensor	LC717A10AR	
Communication Specification	SPI	It can be change to I <sup>2</sup> C Compatible Bus by Parts Exchange

# LC717A10ARGPEVB

**Table 3. JUMPER, PATTERN FOR ADDITIONAL PARTS**

Pattern	Parameter	Set Contents
C2	Pattern for Cref Capacity Adjustment	Implement capacitor of any capacity as needed. (Size: 1608)
C3	Pattern for CrefAdd Capacity Adjustment	Implement capacitor of any capacity as needed. (Size: 1608)
R3	Pattern for SCL Pull-up	When I <sup>2</sup> C compatible bus is chosen by nCS, implement a resistance of 2.2 kΩ. (Size: 1608) (Pull-up VDD)
R4	Pattern for SDA Pull-up	When I <sup>2</sup> C compatible bus is chosen by nCS, implement a resistance of 2.2 kΩ. (Size: 1608) (Pull-up VDD)
R5	Pattern for nCS Pull-up	When I <sup>2</sup> C compatible bus is chosen by nCS, implement a resistance of 2.2 kΩ. (Size: 1608) (Pull-up VDD)
R7	Reserve Pattern	(R7 Initialization: Short) (Size: 1608)
R8	Reserve Pattern	(R8 Initialization: Open) (Size: 1608)
JP1	Pattern for I <sup>2</sup> C Compatible Bus Slave Address Selection	When I <sup>2</sup> C compatible bus is chosen by nCS, set the I <sup>2</sup> C compatible bus slave address by JP1 and JP2. When SPI is chosen, connect to the ground. (JP1 Initialization: Ground Short) 1–2 Short: H Level 2–3 Short: L Level
JP2	Pattern for I <sup>2</sup> C Compatible Bus Slave Address Selection/SO Pull-down	When I <sup>2</sup> C compatible bus is chosen by nCS, set the I <sup>2</sup> C compatible bus slave address by JP1 and JP2. When SPI is chosen, implement a resistance of 100 kΩ between 2 to 3. (It has been implemented.) (JP2 Initialization: Ground Pull-down) 1–2 Short: H Level 2–3 Short: L Level

**Table 4. LC717A10AR I<sup>2</sup>C COMPATIBLE BUS SLAVE ADDRESS**

SA1 Input (JP1)	SA0 Input (JP2)	7bit Slave Address	Binary Notation	8bit Slave Address
Low	Low	0x16	00101100b (Write)	0x2C
			00101101b (Read)	0x2D
Low	High	0x17	00101110b (Write)	0x2E
			00101111b (Read)	0x2F
High	Low	0x18	00110000b (Write)	0x30
			00110001b (Read)	0x31
High	High	0x19	00110010b (Write)	0x32
			00110011b (Read)	0x33

## HOW TO USE

1. Connection of connector pin.  
Solder attached connector pin (8pin) at the position pictured in Figure 3.
2. Connect the LC717A10ARGPEVB to a board with a designed switch pattern. When designing a switch pattern, please refer to the Application and Design Note on the [ON Semiconductor Touch Sensor Homepage](#).
3. Connect LC717A10ARGPEVB to PC through an USB-to-Serial conversion module. Supply the power, and verify the Power LED is turned on.
4. Install evaluation software to PC. The evaluation software is available from the [ON Semiconductor Homepage](#), and selecting “LC717A10 software”. Double-click on the icon “LC717A10App.exe” from the installed folder and start it.
5. Press RESET Switch when evaluation board is acting strange.
6. Please note: If the user directly touches the LSI on the evaluation board or patterns with their finger, it may cause malfunction or breakdown.

# LC717A10ARGPGEVB

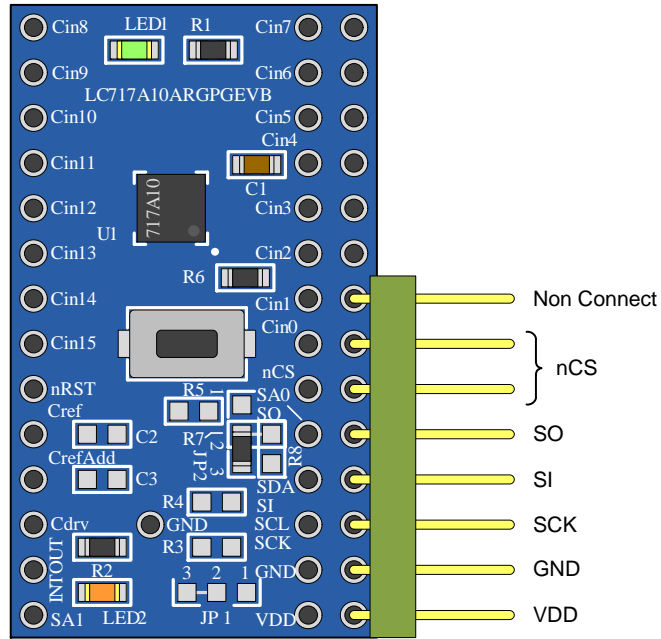

**Figure 3. Connection of Connector Pin**

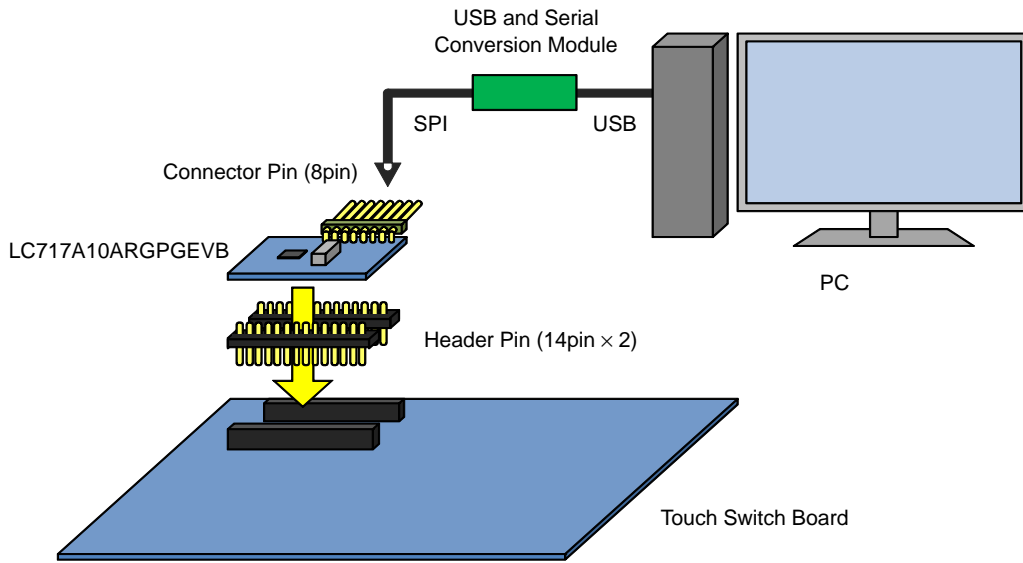

(Other than LC717A10ARGPGEVB and Connector Pin (8pin) are not Attached.)

**Figure 4. Connection Example of LC717A10ARGPGEVB**

# LC717A10ARGPGEVB

## CIRCUIT DIAGRAMS

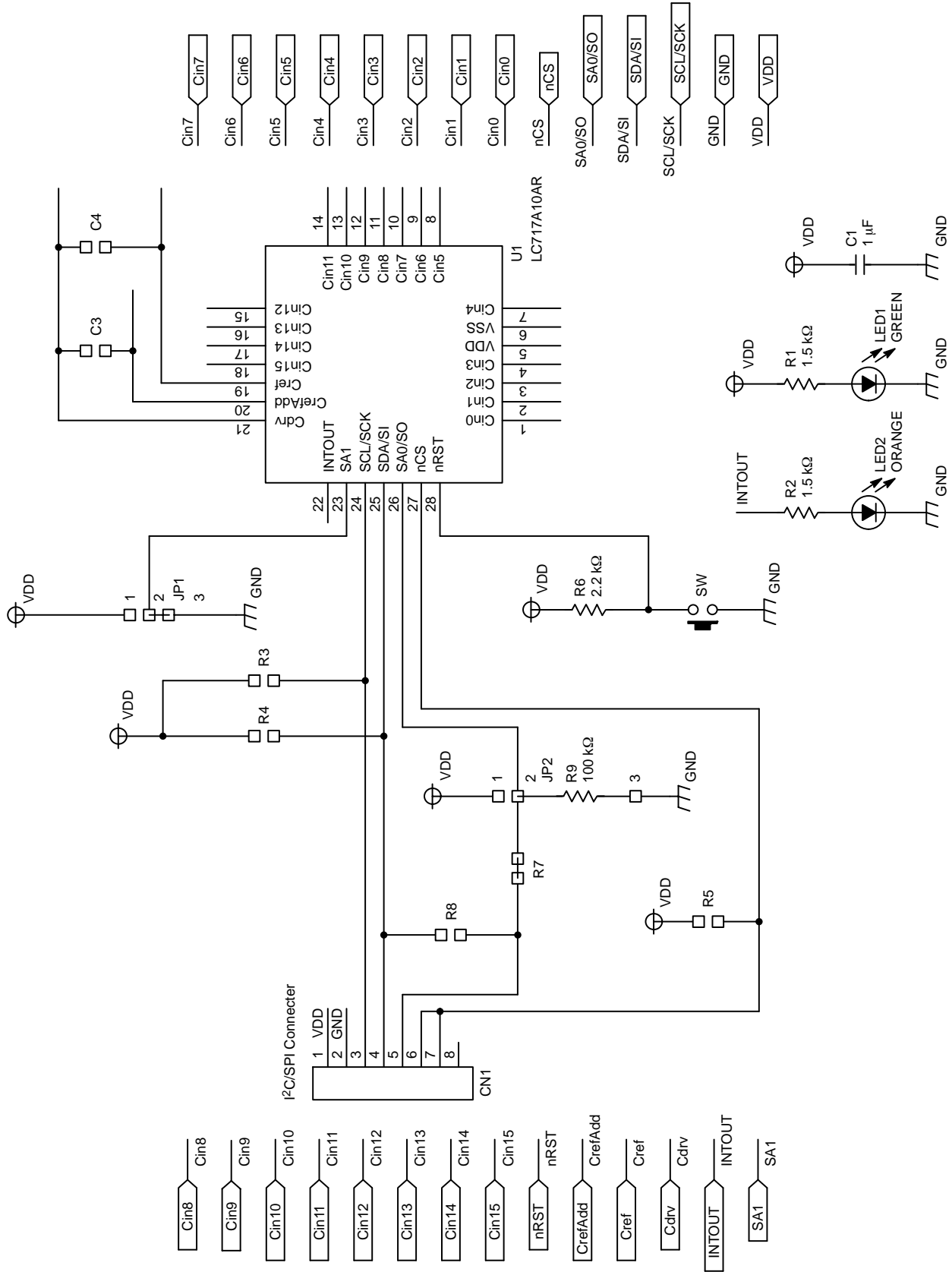



Figure 5. Circuit Diagrams

# LC717A10ARGPGEVB

## PRECAUTION FOR USE

For approach in the use of LSI and design rule of the switch pattern: Please refer to the Application Note and Design Note in [ON Semiconductor Touch Sensor Homepage](#).

ON Semiconductor and the  are registered trademarks of Semiconductor Components Industries, LLC (SCILLC) or its subsidiaries in the United States and/or other countries. SCILLC owns the rights to a number of patents, trademarks, copyrights, trade secrets, and other intellectual property. A listing of SCILLC's product/patent coverage may be accessed at [www.onsemi.com/site/pdf/Patent-Marking.pdf](http://www.onsemi.com/site/pdf/Patent-Marking.pdf). SCILLC reserves the right to make changes without further notice to any products herein. SCILLC makes no warranty, representation or guarantee regarding the suitability of its products for any particular purpose, nor does SCILLC assume any liability arising out of the application or use of any product or circuit, and specifically disclaims any and all liability, including without limitation special, consequential or incidental damages. "Typical" parameters which may be provided in SCILLC data sheets and/or specifications can and do vary in different applications and actual performance may vary over time. All operating parameters, including "Typicals" must be validated for each customer application by customer's technical experts. SCILLC does not convey any license under its patent rights nor the rights of others. SCILLC products are not designed, intended, or authorized for use as components in systems intended for surgical implant into the body, or other applications intended to support or sustain life, or for any other application in which the failure of the SCILLC product could create a situation where personal injury or death may occur. Should Buyer purchase or use SCILLC products for any such unintended or unauthorized application, Buyer shall indemnify and hold SCILLC and its officers, employees, subsidiaries, affiliates, and distributors harmless against all claims, costs, damages, and expenses, and reasonable attorney fees arising out of, directly or indirectly, any claim of personal injury or death associated with such unintended or unauthorized use, even if such claim alleges that SCILLC was negligent regarding the design or manufacture of the part. SCILLC is an Equal Opportunity/Affirmative Action Employer. This literature is subject to all applicable copyright laws and is not for resale in any manner.

### PUBLICATION ORDERING INFORMATION

#### LITERATURE FULFILLMENT:

Literature Distribution Center for ON Semiconductor  
P.O. Box 5163, Denver, Colorado 80217 USA  
**Phone:** 303-675-2175 or 800-344-3860 Toll Free USA/Canada  
**Fax:** 303-675-2176 or 800-344-3867 Toll Free USA/Canada  
**Email:** [orderlit@onsemi.com](mailto:orderlit@onsemi.com)

**N. American Technical Support:** 800-282-9855 Toll Free  
USA/Canada  
**Europe, Middle East and Africa Technical Support:**  
Phone: 421 33 790 2910  
**Japan Customer Focus Center**  
Phone: 81-3-5817-1050

**ON Semiconductor Website:** [www.onsemi.com](http://www.onsemi.com)

**Order Literature:** <http://www.onsemi.com/orderlit>

For additional information, please contact your local Sales Representative

Компания «Life Electronics» занимается поставками электронных компонентов импортного и отечественного производства от производителей и со складов крупных дистрибьюторов Европы, Америки и Азии.

С конца 2013 года компания активно расширяет линейку поставок компонентов по направлению коаксиальный кабель, кварцевые генераторы и конденсаторы (керамические, пленочные, электролитические), за счёт заключения дистрибьюторских договоров

Мы предлагаем:

- Конкурентоспособные цены и скидки постоянным клиентам.
- Специальные условия для постоянных клиентов.
- Подбор аналогов.
- Поставку компонентов в любых объемах, удовлетворяющих вашим потребностям.
- Приемлемые сроки поставки, возможна ускоренная поставка.
- Доставку товара в любую точку России и стран СНГ.
- Комплексную поставку.
- Работу по проектам и поставку образцов.
- Формирование склада под заказчика.
- Сертификаты соответствия на поставляемую продукцию (по желанию клиента).
- Тестирование поставляемой продукции.
- Поставку компонентов, требующих военную и космическую приемку.
- Входной контроль качества.
- Наличие сертификата ISO.

В составе нашей компании организован Конструкторский отдел, призванный помогать разработчикам, и инженерам.

Конструкторский отдел помогает осуществить:

- Регистрацию проекта у производителя компонентов.
- Техническую поддержку проекта.
- Защиту от снятия компонента с производства.
- Оценку стоимости проекта по компонентам.
- Изготовление тестовой платы монтаж и пусконаладочные работы.



Тел: +7 (812) 336 43 04 (многоканальный)

Email: [org@lifeelectronics.ru](mailto:org@lifeelectronics.ru)