

NOTES:

- DRAWING TO BE INTERPRETED IN ACCORDANCE WITH THE CURRENT REVISION OF ASME Y14.5.
- THIS PART/PRODUCT IS TO BE MANUFACTURED WITH THE LATEST APPLICABLE REGULATIONS OF EC DIRECTIVES FOR THE RESTRICTION OF THE USE OF HAZARDOUS SUBSTANCES IN ELECTRICAL AND ELECTRONIC EQUIPMENT (ROHS), WASTE ELECTRICAL AND ELECTRONIC EQUIPMENT (WEEE) AND REGISTRATION, EVALUATION, AUTHORIZATION AND RESTRICTION OF CHEMICALS (REACH).
- OUTPUTS ARE FROM THE CENTER TO THE FULL TRAVEL POSITION.
 OPTIONS "AA", "BB", "CC", "DD", "EE", "FF" PROVIDE INCREASED VOLTAGE IN +Y; AND DECREASING VOLTAGE IN -Y DIRECTION FROM ONE OUTPUT PER AXIS.
 OPTIONS "GG" AND "HH" PROVIDE INCREASING VOLTAGES IN ALL DIRECTIONS (+Y, -Y) FROM 2 OUTPUTS PER AXIS.
- OPTIONS "BB" AND "EE" PROVIDE REDUNDANT OUTPUT 2 WHICH DUPLICATES OUTPUT 1.
 OPTIONS "CC" AND "FF" PROVIDE REDUNDANT OUTPUT 2 WHICH IS INVERSE OF OUTPUT 1.
- SEE PAGE 3 FOR ALTERNATE BUTTON DESIGN. ONLY BUTTON STYLE "2", "5", AND "6" ARE OFFERED WITH A WATERTIGHT PANEL SEAL.
- MARKING TO INCLUDE: "OTTO" P/N & DATE CODE "YYWW".

HTL2-

HTL2-

REV	OCN #	DATE	APR
A	044213	17 JUL 08	LBG
B	046891	19 JAN 09	LBG
C	063013	19 SEP 11	DCF
D	063582	28 OCT 11	KLW
E	066712	27 JUL 12	DCF
F	070736	31 MAY 13	DCF
G	071505	08 AUG 13	DCF

- 5** BUTTON STYLE
 1 = CASTLE
 2 = EXTERNAL CASTLE BOOT
 3 = SHORT DOUBLE STADIUM
 4 = TALL CONCAVE STADIUM
 5 = EXTERNAL BAT HANDLE BOOT
 6 = EXTERNAL SMOOTH BOOT
 7 = LONG CONCAVE Y AXIS BUTTON
- CASE STYLE**
 1 = .970 SQ.
- 5** SEAL
 1 = DUSTTIGHT
 2 = WATERTIGHT
- TRAVEL**
 1 = 25 DEGREES
- GATING**
 1. SINGLE AXIS
- OPERATE FORCE**
 1 = 16 OZ
- OUTPUT 1** **3**
 AA = 2.5+/-2.0 VDC
 BB = 2.5+/-2.0 VDC
 CC = 2.5+/-2.0 VDC
 DD = 2.5+/-1.5 VDC
 EE = 2.5+/-1.5 VDC
 FF = 2.5+/-1.5 VDC
 GG = 0.5-4.5 VDC
 HH = 1-4 VDC
- OUTPUT 2** **4**
 NONE
 2.5+/-2.0 VDC
 2.5+/-2.0 VDC
 NONE
 2.5+/-1.5 VDC
 2.5+/-1.5 VDC
 0.5-4.5 VDC
 1-4 VDC
- TERMINATION**
 1 = WIRE LEADS, 22 AWG, UL1569
 2 = PINS
 3 = WIRE LEADS, 24 AWG, SAE AS22759
- BUTTON COLOR**
 2 = BLACK

PRODUCT SPECIFICATIONS

ELECTRICAL:

RATED AT V _{cc} = 5V @ 20°C LOAD = 1ma (4.7KΩ)	UNITS	MIN	TYP	MAX
SUPPLY VOLTAGE, V _{cc}	VDC	4.50	5.00	5.50
OUTPUT VOLTAGE TOLERANCE AT CENTER (SEE APPROPRIATE GRAPH FOR OUTPUT VALUES)	VDC @5V V _{cc}	-.25	NA	+.25
OUTPUT VOLTAGE TOLERANCE FULL TRAVEL (SEE APPROPRIATE GRAPH FOR OUTPUT VALUES)	VDC @5V V _{cc}	-.25	NA	+.25
SUPPLY CURRENT PER SENSOR B=0, V _{cc} =5V, I _{out} =0	mA	NA	NA	10.0
OUTPUT SOURCE CURRENT LIMIT B=X*, V _o =0	mA	-1.00	NA	1.00
OUTPUT RESISTANCE I _o < -2 mA	Ω	NA	1.00	10.00

MECHANICAL:

MECHANICAL LIFE ALL DIRECTIONS	1,000,000 CYCLES			
TRAVEL ANGLE	DEGREES	23	25	27
OPERATING FORCE (W/BOOT) AT TOP OF BUTTON, @ 20°C	OZ	NA	16	20
MAX. ALLOWABLE VERTICAL FORCE ON BUTTON	LBS	NA	NA	25
MAX. ALLOWABLE RADIAL FORCE ON BUTTON	LBS	NA	NA	25
MAX. ALLOWABLE TORQUE ON BUTTON ABOUT SHAFT AXIS	IN-LBS	NA	NA	5.5

ENVIRONMENTAL:

OPERATING TEMPERATURE	°C	-40	20	85
ELECTRONICS SEAL INTEGRITY	WATERTIGHT PER IP68S, 1 METER			
EMI/RFI WITHSTAND	PER SAE J1113 CONTACT FACTORY FOR DETAILS			

MATERIAL:

BOOT	ELASTOMER, BLACK
BUTTON	THERMOPLASTIC, BLACK
CASE	THERMOPLASTIC, BLACK
FLANGE	THERMOPLASTIC, BLACK
HARDWARE	4X ITW FASTEX PANEL FASTENER P/N 36030002, OR EQUIVALENT

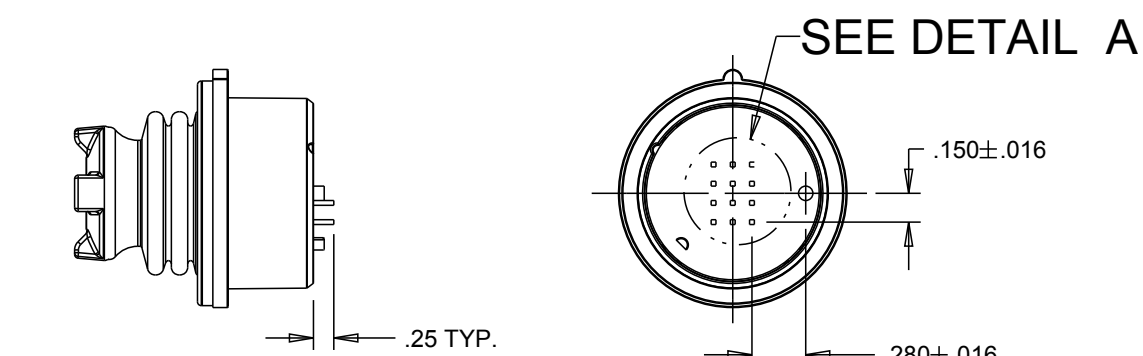

PINS NOT PRESENT IN ALL CONFIGURATIONS

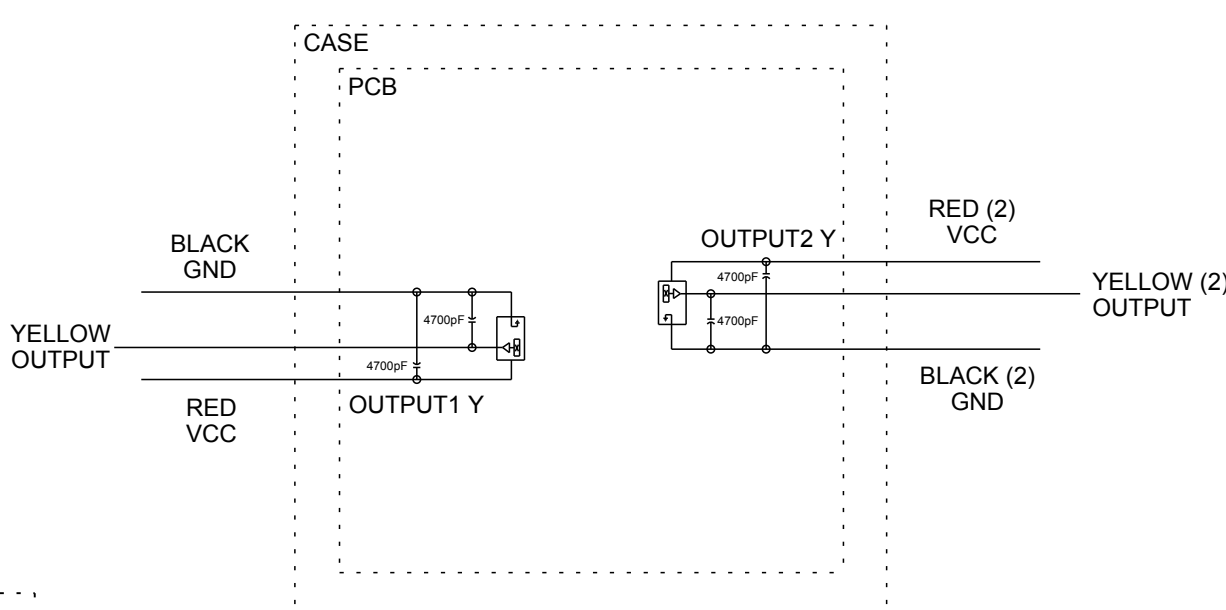

DETAIL A

SCALE 4:1
ALL PINS NOT PRESENT IN ALL CONFIGURATIONS

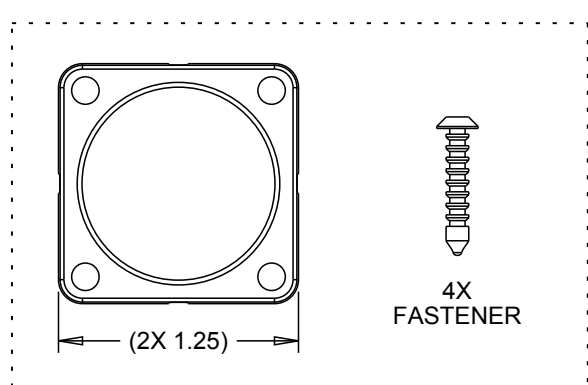

SHIPPED UNASSEMBLED

ALL WIRES NOT PRESENT IN ALL CONFIGURATIONS

OUTPUT2 NOT PRESENT IN ALL CONFIGURATIONS

UNLESS OTHERWISE SPECIFIED:
DIMENSIONS ARE IN INCHES.
TOLERANCES:
.XX ±.03
.XXX ±.010
ANGLES ±2°
DO NOT SCALE

KEY CHARACTERISTICS
SPECIAL REQUIREMENT

OTTO
CARPENTERSVILLE, ILLINOIS USA

DESCRIPTION
HTL2, LINEAR HALL EFFECT
2-WAY TOGGLE

DRWN. JLW	SIZE C	FSCM NO 21649	DRAWING NO. HTL2-	REV. G
CHKD. MRM				
APPD. AH				

OPTION AA



OPTION BB



OPTION CC



OPTION DD



OPTION EE



OPTION FF



OPTION GG



OPTION HH



UNLESS OTHERWISE SPECIFIED
DIMENSIONS ARE IN INCHES.
TOLERANCES ARE AS LISTED.
MUST BE FREE FROM BURRS
AND SHARP EDGES

TOLERANCES
.XX ±.03
.XXX ±.010
ANGLES ±2°
DO NOT SCALE DRAWING

THIS DOCUMENT IS THE CONFIDENTIAL
PROPERTY OF OTTO ENGINEERING, INC..
IT IS NOT TO BE USED IN ANY WAY
DETRIMENTAL TO THE INTERESTS
OF OTTO ENGINEERING, INC.

DRWN. JLW	SIZE C	FSCM NO. 21649	DRAWING NO. HTL2-	REV. G
CHKD. MRM				
APPD. AH				
WT.	THIRD ANGLE PROJECTION	Scale 1:1	Sheet 2 OF 4	

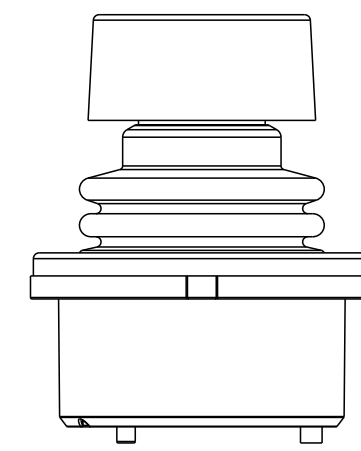
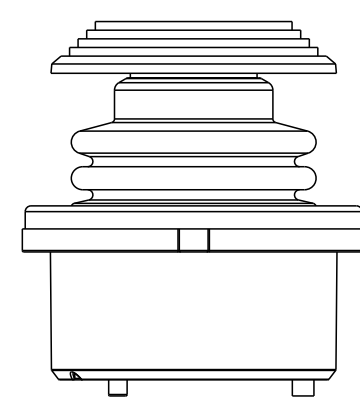
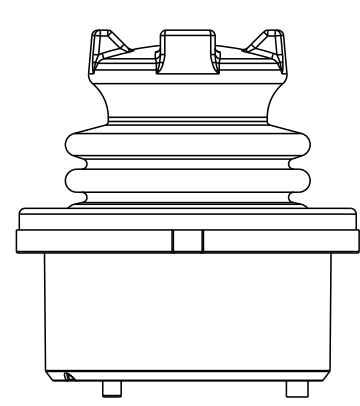
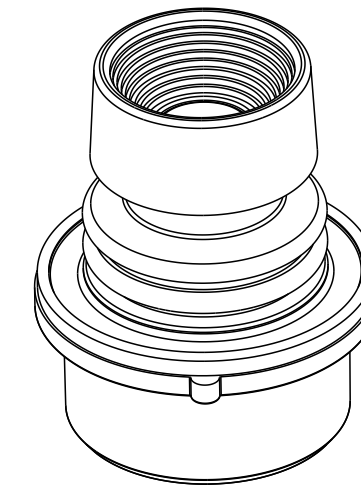
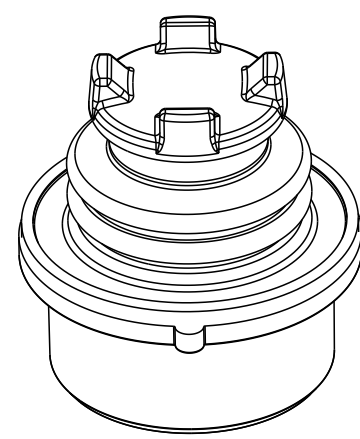

BUTTON STYLE 1
(CASTLE)

BUTTON STYLE 2
(EXTERNAL CASTLE BOOT)

BUTTON STYLE 3
(SHORT DOUBLE STADIUM)

BUTTON STYLE 4
(TALL CONCAVE STADIUM)

BUTTON STYLE CONFIGURATION

UNLESS OTHERWISE SPECIFIED DIMENSIONS ARE IN INCHES. TOLERANCES ARE AS LISTED. MUST BE FREE FROM BURRS AND SHARP EDGES	TOLERANCES		THIS DOCUMENT IS THE CONFIDENTIAL PROPERTY OF OTTO ENGINEERING, INC.. IT IS NOT TO BE USED IN ANY WAY DETRIMENTAL TO THE INTERESTS OF OTTO ENGINEERING, INC.	DRWN. JLW	SIZE	FSCM NO	DRAWING NO.	REV.
	.XX	±.03		CHKD. DCF	C	21649	HTL2-_____	G
	.XXX	±.010		APPD. AH				
	ANGLES ±2°			WT.	THIRD ANGLE PROJECTION	Scale 1:1	Sheet 3 OF 4	
DO NOT SCALE DRAWING								

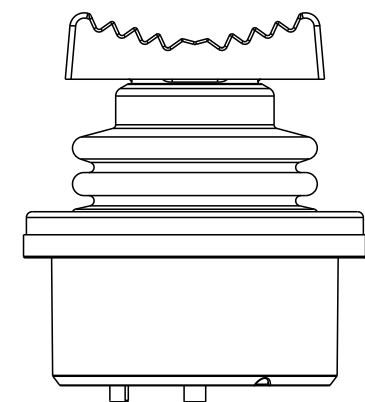
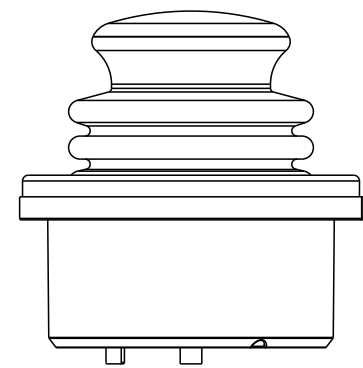
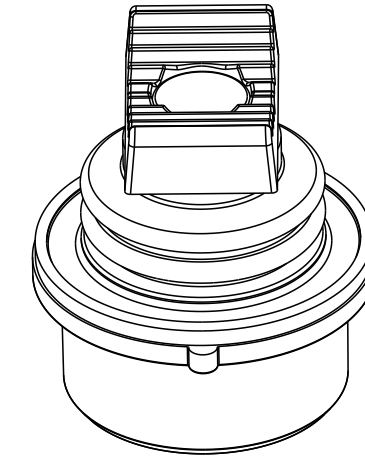
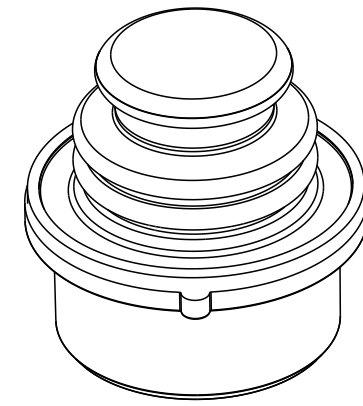

**BUTTON STYLE 5
(EXTERNAL BAT
HANDLE BOOT)**

**BUTTON STYLE 6
(EXTERNAL SMOOTH BOOT)**

**BUTTON STYLE 7
(LONG CONCAVE Y AXIS BUTTON)**

BUTTON STYLE CONFIGURATION

UNLESS OTHERWISE SPECIFIED DIMENSIONS ARE IN INCHES. TOLERANCES ARE AS LISTED. MUST BE FREE FROM BURRS AND SHARP EDGES	TOLERANCES	THIS DOCUMENT IS THE CONFIDENTIAL PROPERTY OF OTTO ENGINEERING, INC.. IT IS NOT TO BE USED IN ANY WAY DETRIMENTAL TO THE INTERESTS OF OTTO ENGINEERING, INC.	DRWN. JLW	SIZE	FSCM NO	DRAWING NO.	REV.
	.XX ±.03 .XXX ±.010 ANGLES ±2° DO NOT SCALE DRAWING		CHKD. DCF	C	21649	HTL2-	G
			APPD. AH	THIRD ANGLE PROJECTION	Scale 1:1	Sheet 4 OF 4	

Компания «Life Electronics» занимается поставками электронных компонентов импортного и отечественного производства от производителей и со складов крупных дистрибьюторов Европы, Америки и Азии.

С конца 2013 года компания активно расширяет линейку поставок компонентов по направлению коаксиальный кабель, кварцевые генераторы и конденсаторы (керамические, пленочные, электролитические), за счёт заключения дистрибьюторских договоров

Мы предлагаем:

- Конкурентоспособные цены и скидки постоянным клиентам.
- Специальные условия для постоянных клиентов.
- Подбор аналогов.
- Поставку компонентов в любых объемах, удовлетворяющих вашим потребностям.
- Приемлемые сроки поставки, возможна ускоренная поставка.
- Доставку товара в любую точку России и стран СНГ.
- Комплексную поставку.
- Работу по проектам и поставку образцов.
- Формирование склада под заказчика.
- Сертификаты соответствия на поставляемую продукцию (по желанию клиента).
- Тестирование поставляемой продукции.
- Поставку компонентов, требующих военную и космическую приемку.
- Входной контроль качества.
- Наличие сертификата ISO.

В составе нашей компании организован Конструкторский отдел, призванный помогать разработчикам, и инженерам.

Конструкторский отдел помогает осуществить:

- Регистрацию проекта у производителя компонентов.
- Техническую поддержку проекта.
- Защиту от снятия компонента с производства.
- Оценку стоимости проекта по компонентам.
- Изготовление тестовой платы монтаж и пусконаладочные работы.



Тел: +7 (812) 336 43 04 (многоканальный)

Email: org@lifeelectronics.ru