



## Index

### Series 18

	<b>Description</b>	<b>Page 431</b>
	<b>Product Assembly</b>	<b>Page 432</b>
	<b>Product Range</b>	
	- pushbuttons for standard mounting	<b>Page 433</b>
	- pushbuttons for flush mounting	<b>Page 434</b>
	- accessories / spare parts	<b>Page 435</b>
	<b>Technical Data</b>	<b>Page 438</b>
	<b>Technical Drawing / Dimension / Layout</b>	<b>Page 439</b>
<b>Circuit Drawing</b>	<b>Page 442</b>	

## General Notes

The series 18 comprises compact indicators for direct connection to 2.2, 12 or 24 VDC and illuminated pushbuttons with maintained or momentary action.

The illuminated pushbuttons are equipped with a snap-action switching system with normally open or normally closed contacts.

The dimensions of the front are 9 x 14 mm, 9 x 9 mm or 9 mm dia. Indicators and illuminated pushbuttons for use with overhanging lenses 14 x 14 mm or 14 mm dia. are also available for recessed front mounting.

## Mounting

Mounting from the front through the mounting aperture 8 mm dia. (15.8 x 15.8 mm resp. 16 mm dia. for recessed versions) is assured even with the wiring already attached (mounting dimensions and spacing see pages 440).

The units are provided with soldering or plug-in terminals.

## Lenses

The flat lenses, which are made of PMMA, PS, are available in various colours and a transparent version. The surface is nonreflecting (matt).

## Illumination

Perfect illumination of the lenses, which can be supplied in various colours, is assured by bipin T1 LEDs in the colours red, yellow and green.

(Compact indicators for connection to 12 or 24 VDC.)

The bipin T1 LED are already integrated in the lenses.

## Position Indication

When a switch with maintained action is actuated, the lens remains in the depressed position mechanically. The state of the switch is apparent at all times from the position of the lens.

## Number structure

18-XXX.OX5X

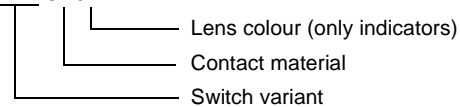

18-9XX.X

Lens

18-9XX.X

Other accessories

Example:

-Illuminated pushbutton; round, momentary action, gold contact; soldering terminals  
18-137.035

-Lens red, circular

18-931.2

All dimensions in mm.

We reserve the right to modify technical data.

## illuminated-/pushbutton



- 1 lens
- 2 switch housing
- 3 fixing nut

## illuminated-/pushbutton, round for flush mounting

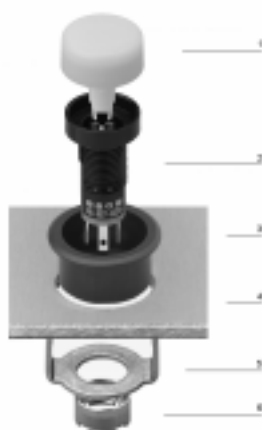

- 1 lens
- 2 switch housing
- 3 front panel
- 4 front ring bezel
- 5 front ring bezel bracket
- 6 fixing nut

## indicator



### recommended accessories:

	voltage/current	colour of lens	connection method	9 x 14 mm part no.	9 x 9 mm part no.	9 mm dia. part no.	circuit drawing	technical drawing	mounting dimension	components layout	
<b>indicator</b> incl. LED, with built-in series resistor for direct connection	12 VDC/20 mA	green	ST	<b>18-041.0055</b>	<b>18-051.0055</b>	<b>18-031.0055</b>	1	1	1	1	0,002
		red	ST	<b>18-041.0052</b>	<b>18-051.0052</b>	<b>18-031.0052</b>	1	1	1	1	0,002
		yellow	ST	<b>18-041.0054</b>	<b>18-051.0054</b>	<b>18-031.0054</b>	1	1	1	1	0,002
	24 VDC/20 mA	green	ST	<b>18-042.0055</b>	<b>18-052.0055</b>	<b>18-032.0055</b>	1	1	1	1	0,002
		red	ST	<b>18-042.0052</b>	<b>18-052.0052</b>	<b>18-032.0052</b>	1	1	1	1	0,002
		yellow	ST	<b>18-042.0054</b>	<b>18-052.0054</b>	<b>18-032.0054</b>	1	1	1	1	0,002
including LED, without built-in series resistor	2,2 VDC/20 mA	green	ST	<b>18-040.0055</b>	<b>18-050.0055</b>	<b>18-030.0055</b>	1	1	1	1	0,002
		red	ST	<b>18-040.0052</b>	<b>18-050.0052</b>	<b>18-030.0052</b>	1	1	1	1	0,002
		yellow	ST	<b>18-040.0054</b>	<b>18-050.0054</b>	<b>18-030.0054</b>	1	1	1	1	0,002

connection method: ST = soldering terminal; PCB plug-in base page 437

technical drawing as of page 439, mounting dimensions, components layouts as of page 440, circuit drawing as of page 442

## illuminated-/pushbutton



### recommended accessories:

lens → 435; lens with LED → 435

	switching system	contacts	switching action	connection method	9 x 14 mm part no.	9 x 9 mm part no.	9 mm dia. part no.	circuit drawing	technical drawing	mounting dimension	components layout	
<b>illuminated-/pushbutton</b>	SA	1NC	main	ST	<b>18-248.035</b>	<b>18-258.035</b>	<b>18-238.035</b>	2	2	1	1	0,002
			mom	ST	<b>18-148.035</b>	<b>18-158.035</b>	<b>18-138.035</b>	4	2	1	1	0,002
		1NO	main	ST	<b>18-247.035</b>	<b>18-257.035</b>	<b>18-237.035</b>	3	2	1	1	0,002
			mom	ST	<b>18-147.035</b>	<b>18-157.035</b>	<b>18-137.035</b>	5	2	1	1	0,002

switching system: SA = snap-action switching element

switching action: main = maintained action, mom = momentary action

connection method: ST = soldering terminal; PCB plug-in base page 437

contacts: NC = normally closed, NO = normally open

technical drawing as of page 439, mounting dimensions, components layouts as of page 440, circuit drawing as of page 442

## indicator for flush mounting



### recommended accessories:

front bezel-set for flush mounting → 436

	voltage/current	colour of lens	connection method	14 x 14 mm part no.	14 mm dia. part no.	circuit drawing	technical drawing	mounting dimension	components layout	
<b>indicator for flush mounting</b> incl. LED, with built-in series resistor for direct connection	12 VDC/20 mA	green	ST	<b>18-081.0055</b>	<b>18-061.0055</b>	1	3	2	2	0,003
		red	ST	<b>18-081.0052</b>	<b>18-061.0052</b>	1	3	2	2	0,003
		yellow	ST	<b>18-081.0054</b>	<b>18-061.0054</b>	1	3	2	2	0,003
	24 VDC/20 mA	green	ST	<b>18-082.0055</b>	<b>18-062.0055</b>	1	3	2	2	0,003
		red	ST	<b>18-082.0052</b>	<b>18-062.0052</b>	1	3	2	2	0,003
		yellow	ST	<b>18-082.0054</b>	<b>18-062.0054</b>	1	3	2	2	0,003
including LED, without built-in series resistor	2,2 VDC/20 mA	green	ST	<b>18-080.0055</b>	<b>18-060.0055</b>	1	3	2	2	0,002
		red	ST	<b>18-080.0052</b>	<b>18-060.0052</b>	1	3	2	2	0,002
		yellow	ST	<b>18-080.0054</b>	<b>18-060.0054</b>	1	3	2	2	0,002

connection method: ST = soldering terminal; PCB plug-in base page 437

[technical drawing as of page 439](#), [mounting dimensions](#), [components layouts as of page 440](#), [circuit drawing as of page 442](#)

## illuminated-/pushbutton for flush mounting



### recommended accessories:

lens overhanging → 435; lens overhanging with LED → 436

front bezel-set for flush mounting → 436

	switching system	contacts	switching action	connection method	19 mm dia. part no.	19 x 19 mm part no.	circuit drawing	technical drawing	mounting dimension	components layout	
<b>illuminated-/pushbutton for flush mounting</b>	SA	1NC	main	ST	<b>18-268.035</b>	<b>18-288.035</b>	2	4	2	2	0,002
			mom	ST	<b>18-168.035</b>	<b>18-188.035</b>	4	4	2	2	0,002
		1NO	main	ST	<b>18-267.035</b>	<b>18-287.035</b>	3	4	2	2	0,002
			mom	ST	<b>18-167.035</b>	<b>18-187.035</b>	5	4	2	2	0,002

switching system: SA = snap-action switching element

switching action: main = maintained action, mom = momentary action





connection method: ST = soldering terminal; PCB plug-in base page 437

contacts: NC = normally closed, NO = normally open





[technical drawing as of page 439](#), [mounting dimensions](#), [components layouts as of page 440](#), [circuit drawing as of page 442](#)

## at front

### lens



	shape	lens	colour	 9 x 14 mm part no.	 9 x 9 mm part no.	9 mm dia. part no.		
<b>lens plastic</b>	flat	translucent, matt	black	<b>18-942.0</b>	<b>18-952.0</b>	<b>18-932.0</b>	0,001	
			green	<b>18-942.5</b>	<b>18-952.5</b>	<b>18-932.5</b>	0,001	
			grey	<b>18-942.8</b>	<b>18-952.8</b>	<b>18-932.8</b>	0,001	
			red	<b>18-942.2</b>	<b>18-952.2</b>	<b>18-932.2</b>	0,001	
			white	<b>18-942.9</b>	<b>18-952.9</b>	<b>18-932.9</b>	0,001	
			yellow	<b>18-942.4</b>	<b>18-952.4</b>	<b>18-932.4</b>	0,001	

### lens with LED

	shape	lens	colour	 9 x 14 mm part no.	 9 x 9 mm part no.	9 mm dia. part no.		
<b>lens with LED</b> plastic, without built-in series resistor, typ. forward voltage 2.2 VDC/20 mA	flat	translucent, matt	green	<b>18-941.5</b>	<b>18-951.5</b>	<b>18-931.5</b>	0,001	
			red	<b>18-941.2</b>	<b>18-951.2</b>	<b>18-931.2</b>	0,001	
			yellow	<b>18-941.4</b>	<b>18-951.4</b>	<b>18-931.4</b>	0,001	



### lens overhanging

for flush mounting

	shape	lens	colour	19 mm dia. part no.	 19 x 19 mm part no.		
<b>lens overhanging plastic</b>	flat	translucent, matt	black	<b>18-962.0</b>	<b>18-982.0</b>	0,001	
			green	<b>18-962.5</b>	<b>18-982.5</b>	0,001	
			grey	<b>18-962.8</b>	<b>18-982.8</b>	0,001	
			red	<b>18-962.2</b>	<b>18-982.2</b>	0,001	
			white	<b>18-962.9</b>	<b>18-982.9</b>	0,001	
			yellow	<b>18-962.4</b>	<b>18-982.4</b>	0,001	



## lens overhanging with LED

for flush mounting



	shape	lens	colour	19 mm dia. part no.	$\varnothing$ 19 x 19 mm part no.		
<b>lens overhanging with LED</b> plastic, without built-in series resistor, typ. forward voltage 2.2 VDC/20 mA	flat	translucent, matt	green	<b>18-961.5</b>	<b>18-981.5</b>	0,001	
			red	<b>18-961.2</b>	<b>18-981.2</b>	0,001	
			yellow	<b>18-961.4</b>	<b>18-981.4</b>	0,001	

## front bezel-set for flush mounting

for overhanging lenses

	material	colour	19 mm dia. part no.	$\varnothing$ 19 x 19 mm part no.		
<b>front bezel-set for flush mounting</b> for lens round	plastic	black	<b>18-920.3</b>	<b>18-920.2</b>	0,006	
for lens square	plastic	black		<b>18-920.1</b>	0,006	



## blind plug

	colour	$\varnothing$ 9 x 9 mm part no.	9 mm dia. part no.		
<b>blind plug</b>	black	<b>19-948.0</b>	<b>19-949.0</b>	0,001	



## at back



### PCB plug-in base

	for	pin orientation	part no.	technical drawing	components layout		
<b>PCB plug-in base</b>	soldering terminal	axial	<b>18-945</b>	5	3	0,001	 
		right-angled	<b>18-946</b>	6	4	0,001	



technical drawing as of page 439. components layouts as of page 440

## assembling

### lens remover

	part no.		
<b>lens remover</b>	<b>18-910</b>	0,002	

### mounting tool

	part no.		
<b>mounting tool</b> for tightening (or loosening) fixing nuts starting torque fixing nut max. 20 Ncm	<b>19-905</b>	0,011	

## actuator with snap-action switching element

### switching system

The snap-action switching system was designed for switching low powers in electronic circuits.  
Single-break snap-action contact.

### material

#### actuator case

polyamide; colour black

#### lens

polymethylacrylate PMMA, polycarbonate PC

#### material of contacts

gold contact on nickel plating

### switch rating

10  $\mu$ A/100  $\mu$ V to 100 mA at 42 VAC/VDC

### volume resistance

$\leq$  100 m $\Omega$  starting value (initial)  
IEC 512-2, Test 2 b

### mechanical characteristics

#### actuating force

1.4 N

#### ambient air temperature

-25°C to +65°C  
(as per DIN IEC 68-)

#### connection method

The terminals can be used as soldering terminals.  
max.wire diameter: 2 of 0.5 mm<sup>2</sup>  
max.wire ccross-section of stranded cable: 1 x 0.75 mm<sup>2</sup>  
wire cross-section of terminal: 1.6 x 0.4 mm

#### degree of protection

front as per IEC 529: IP 40

#### mechanical life

as per IEC 512-5, test 9a  
momentary action 2 mio. cycles of operation  
maintained action 1 mio. cycles of operation

#### rebound time

$\leq$  2.5 ms

#### resistance to shock

(single impacts, semi-sinusoidal)  
50 g for 11 ms as per IEC 68-2-27

#### resistance to vibration

(sinusoidal) 10 g at 10-2000 Hz, amplitude 0.75 mm as per IEC 512-4-4

#### starting torque

for fixing nut max. 20 Ncm

#### storage temperature

-40°C to +80°C  
(as per DIN IEC 68-)

#### travel

2.2 mm  $\pm$  0.2 mm

### electrical characteristics

#### electric strength

500 VAC, 50 Hz, 1 min. between all terminals and earth, as per IEC 512-2-11

#### electrical life

$\geq$  500.000 cycles of operation at 30 VDC/100 mA to IEC 512-5, Test 9c

#### power consumption

20 mA

## technical drawing

### 1 indicator

page 433

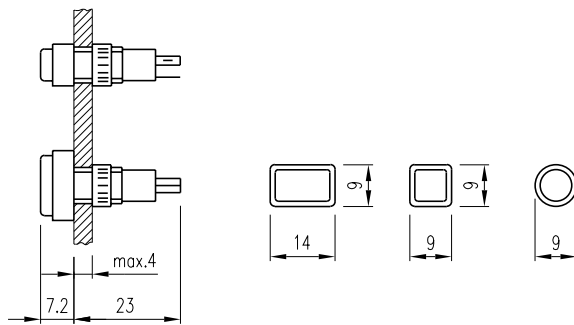

### 2 illuminated-/pushbutton

page 433

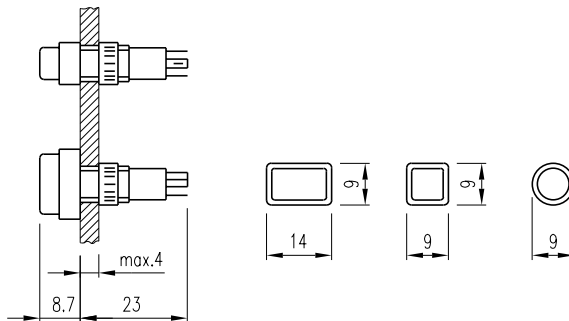

### 3 indicator for flush mounting

page 434

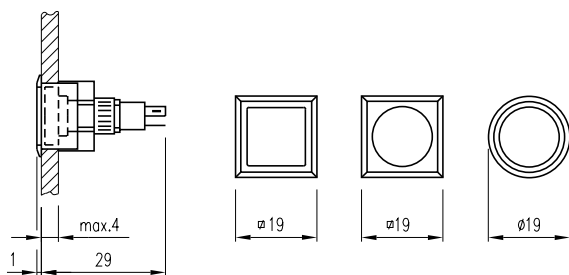

### 4 illuminated-/pushbutton for flush mounting

page 434

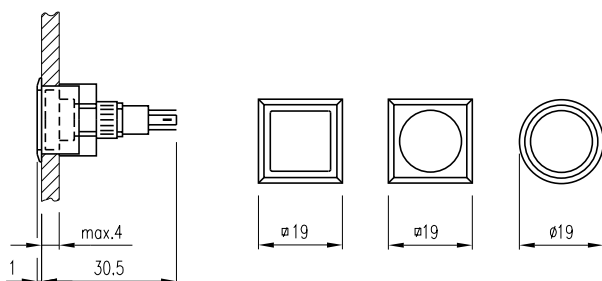

**5 PCB plug-in base**  
page 437

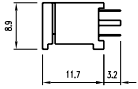

**6 PCB plug-in base**  
page 437

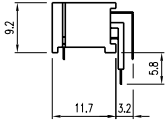

## mounting dimension

**1 indicator, illuminated-/pushbutton**  
page 433

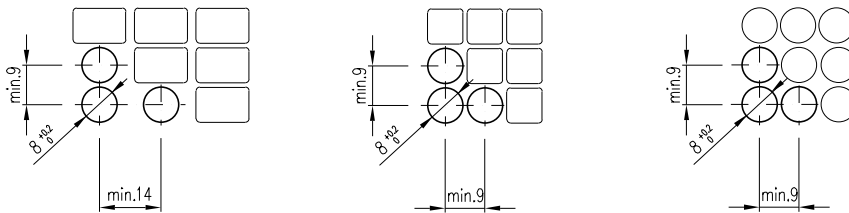

**2 indicator for flush mounting, illuminated-/pushbutton for flush mounting**  
page 434

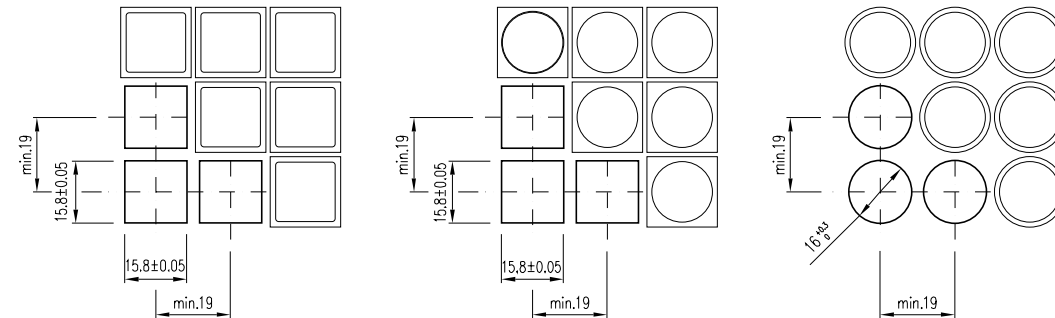

## components layouts

**1 indicator, illuminated-/pushbutton**  
page 433



**2 indicator for flush mounting, illuminated-/pushbutton for flush mounting**  
page 434

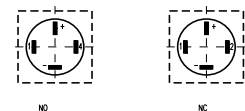

3 PCB plug-in base  
page 437

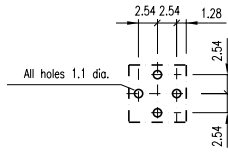

4 PCB plug-in base  
page 437

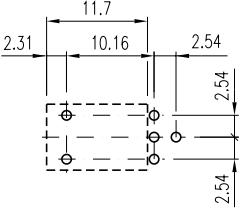

	circuit drawing
1	
2	
3	
4	
5	

Компания «Life Electronics» занимается поставками электронных компонентов импортного и отечественного производства от производителей и со складов крупных дистрибьюторов Европы, Америки и Азии.

С конца 2013 года компания активно расширяет линейку поставок компонентов по направлению коаксиальный кабель, кварцевые генераторы и конденсаторы (керамические, пленочные, электролитические), за счёт заключения дистрибьюторских договоров

Мы предлагаем:

- Конкурентоспособные цены и скидки постоянным клиентам.
- Специальные условия для постоянных клиентов.
- Подбор аналогов.
- Поставку компонентов в любых объемах, удовлетворяющих вашим потребностям.
- Приемлемые сроки поставки, возможна ускоренная поставка.
- Доставку товара в любую точку России и стран СНГ.
- Комплексную поставку.
- Работу по проектам и поставку образцов.
- Формирование склада под заказчика.
- Сертификаты соответствия на поставляемую продукцию (по желанию клиента).
- Тестирование поставляемой продукции.
- Поставку компонентов, требующих военную и космическую приемку.
- Входной контроль качества.
- Наличие сертификата ISO.

В составе нашей компании организован Конструкторский отдел, призванный помогать разработчикам, и инженерам.

Конструкторский отдел помогает осуществить:

- Регистрацию проекта у производителя компонентов.
- Техническую поддержку проекта.
- Защиту от снятия компонента с производства.
- Оценку стоимости проекта по компонентам.
- Изготовление тестовой платы монтаж и пусконаладочные работы.



Тел: +7 (812) 336 43 04 (многоканальный)

Email: [org@lifeelectronics.ru](mailto:org@lifeelectronics.ru)