



# PCA9532

16-bit I<sup>2</sup>C-bus LED dimmer

Rev. 4.1 — 22 August 2016

Product data sheet

## 1. General description

The PCA9532 is a 16-bit I<sup>2</sup>C-bus and SMBus I/O expander optimized for dimming LEDs in 256 discrete steps for Red/Green/Blue (RGB) color mixing and back light applications.

The PCA9532 contains an internal oscillator with two user programmable blink rates and duty cycles coupled to the output PWM. The LED brightness is controlled by setting the blink rate high enough (> 100 Hz) that the blinking cannot be seen and then using the duty cycle to vary the amount of time the LED is on and thus the average current through the LED.

The initial setup sequence programs the two blink rates/duty cycles for each individual PWM. From then on, only one command from the bus master is required to turn individual LEDs ON, OFF, BLINK RATE 1 or BLINK RATE 2. Based on the programmed frequency and duty cycle, BLINK RATE 1 and BLINK RATE 2 will cause the LEDs to appear at a different brightness or blink at periods up to 1.69 second. The open-drain outputs directly drive the LEDs with maximum output sink current of 25 mA per bit and 200 mA per package (100 mA per octal).

To blink LEDs at periods greater than 1.69 second the bus master (MCU, MPU, DSP, chip set, etc.) must send repeated commands to turn the LED on and off as is currently done when using normal I/O expanders like the NXP Semiconductors PCF8575 or PCA9555. Any bits not used for controlling the LEDs can be used for General Purpose parallel Input/Output (GPIO) expansion, which provides a simple solution when additional I/O is needed for ACPI power switches, sensors, push-buttons, alarm monitoring, fans, etc.

The active LOW hardware reset pin ( $\overline{\text{RESET}}$ ) and Power-On Reset (POR) initializes the registers to their default state, all zeroes, causing the bits to be set HIGH (LED off).

Three hardware address pins on the PCA9532 allow eight devices to operate on the same bus.

## 2. Features and benefits

- 16 LED drivers (on, off, flashing at a programmable rate)
- Two selectable, fully programmable blink rates (frequency and duty cycle) between 0.591 Hz and 152 Hz (1.69 second and 6.58 milliseconds)
- 256 brightness steps
- Input/outputs not used as LED drivers can be used as regular GPIOs
- Internal oscillator requires no external components
- I<sup>2</sup>C-bus interface logic compatible with SMBus
- Internal power-on reset



- Noise filter on SCL/SDA inputs
- Active LOW reset input
- 16 open-drain outputs directly drive LEDs to 25 mA
- Controlled edge rates to minimize ground bounce
- No glitch on power-up
- Supports hot insertion
- Low standby current
- Operating power supply voltage range of 2.3 V to 5.5 V
- 0 Hz to 400 kHz clock frequency
- ESD protection exceeds 2000 V HBM per JESD22-A114, 150 V MM per JESD22-A115 and 1000 V CDM per JESD22-C101
- Latch-up testing is done to JEDEC Standard JESD78 which exceeds 100 mA
- Packages offered: SO24, TSSOP24, HVQFN24

### 3. Ordering information

**Table 1. Ordering information**

$T_{amb} = -40\text{ }^{\circ}\text{C}$  to  $+85\text{ }^{\circ}\text{C}$ .

Type number	Topside mark	Package		Version
		Name	Description	
PCA9532D	PCA9532D	SO24	plastic small outline package; 24 leads; body width 7.5 mm	SOT137-1
PCA9532PW	PCA9532PW	TSSOP24	plastic thin shrink small outline package; 24 leads; body width 4.4 mm	SOT355-1
PCA9532BS	9532	HVQFN24	plastic thermal enhanced very thin quad flat package; no leads; 24 terminals; body 4 × 4 × 0.85 mm	SOT616-1

### 4. Block diagram

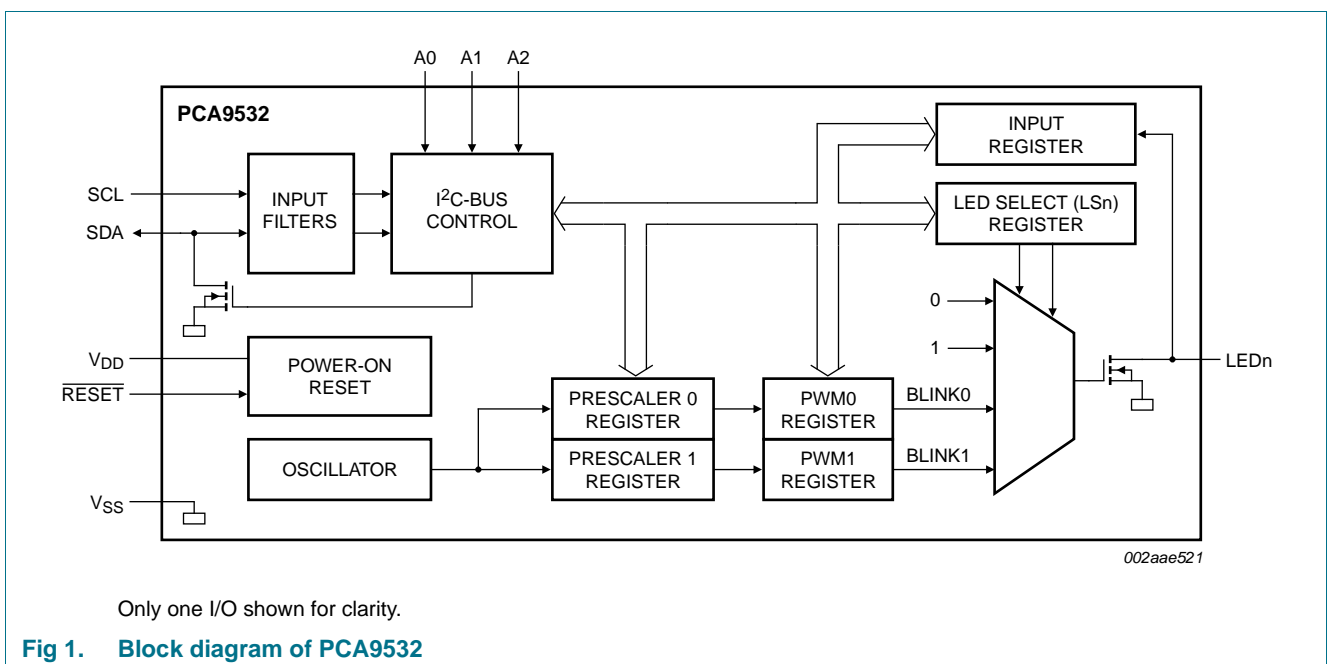

## 5. Pinning information

### 5.1 Pinning

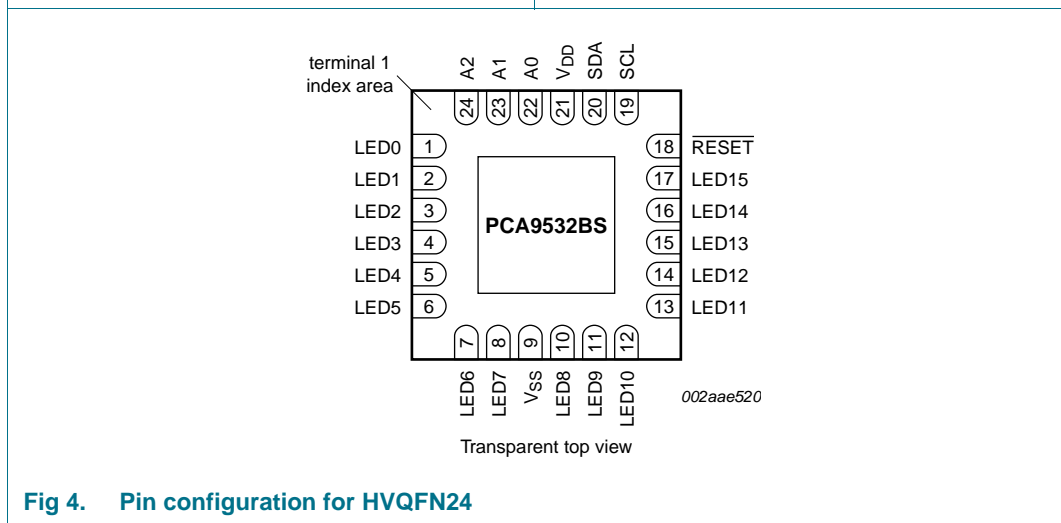
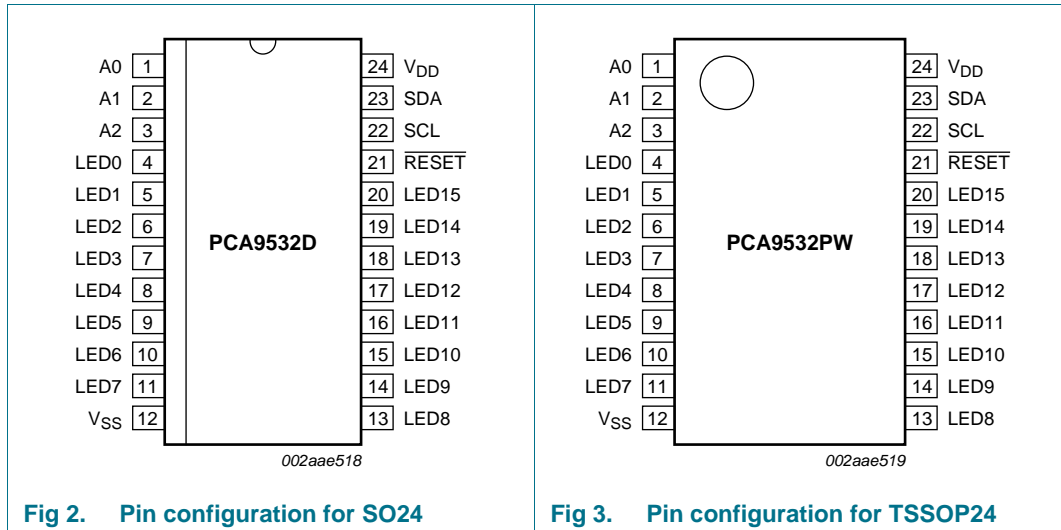

## 5.2 Pin description

Table 2. Pin description

Symbol	Pin		Description
	SO24, TSSOP24	HVQFN24	
A0	1	22	address input 0
A1	2	23	address input 1
A2	3	24	address input 2
LED0	4	1	LED driver 0
LED1	5	2	LED driver 1
LED2	6	3	LED driver 2
LED3	7	4	LED driver 3
LED4	8	5	LED driver 4
LED5	9	6	LED driver 5
LED6	10	7	LED driver 6
LED7	11	8	LED driver 7
V <sub>SS</sub>	12	9 <sup>[1]</sup>	supply ground
LED8	13	10	LED driver 8
LED9	14	11	LED driver 9
LED10	15	12	LED driver 10
LED11	16	13	LED driver 11
LED12	17	14	LED driver 12
LED13	18	15	LED driver 13
LED14	19	16	LED driver 14
LED15	20	17	LED driver 15
$\overline{\text{RESET}}$	21	18	reset input (active LOW)
SCL	22	19	serial clock line
SDA	23	20	serial data line
V <sub>DD</sub>	24	21	supply voltage

- [1] HVQFN24 package die supply ground is connected to both V<sub>SS</sub> pin and exposed center pad. V<sub>SS</sub> pin must be connected to supply ground for proper device operation. For enhanced thermal, electrical, and board level performance, the exposed pad needs to be soldered to the board using a corresponding thermal pad on the board and for proper heat conduction through the board, thermal vias need to be incorporated in the PCB in the thermal pad region.

## 6. Functional description

Refer to [Figure 1 “Block diagram of PCA9532”](#).

### 6.1 Device address

Following a START condition, the bus master must output the address of the slave it is accessing. The address of the PCA9532 is shown in [Figure 5](#). To conserve power, no internal pull-up resistors are incorporated on the hardware selectable address pins and they must be pulled HIGH or LOW.

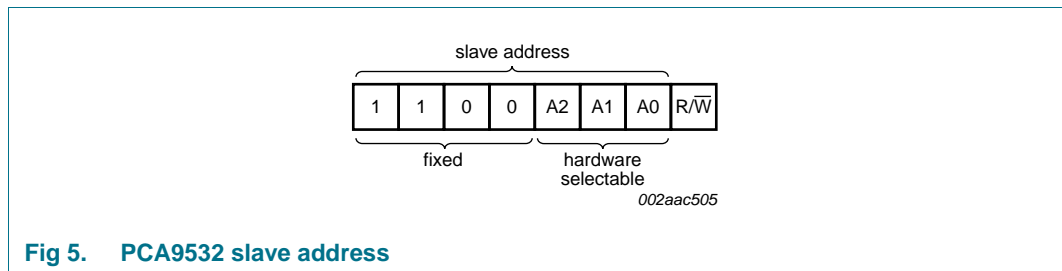
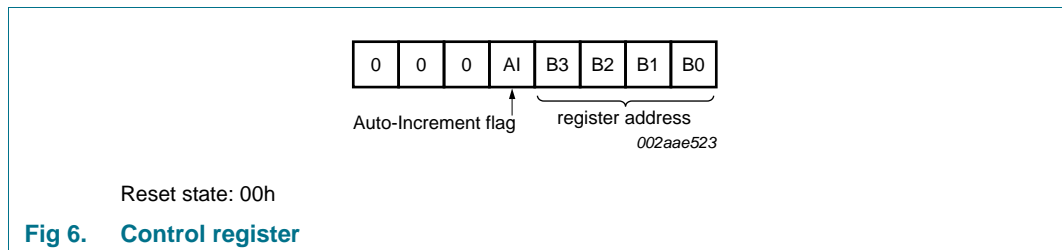

**Fig 5. PCA9532 slave address**

The last bit of the address byte defines the operation to be performed. When set to logic 1 a read is selected, while a logic 0 selects a write operation.

### 6.2 Control register

Following the successful acknowledgement of the slave address, the bus master will send a byte to the PCA9532, which will be stored in the Control register.



Reset state: 00h

**Fig 6. Control register**

The lowest 4 bits are used as a pointer to determine which register will be accessed.

If the Auto-Increment (AI) flag is set, the four low order bits of the Control register are automatically incremented after a read or write. This allows the user to program the registers sequentially. The contents of these bits will rollover to '0000' after the last register is accessed.

When Auto-Increment flag is set (AI = 1) and a read sequence is initiated, the sequence must start by reading a register different from the INPUT0 register (B3 B2 B1 B0 ≠ 0 0 0 0).

Only the 4 least significant bits are affected by the AI flag. Unused bits must be programmed with zeroes.

## 6.2.1 Control register definition

Table 3. Register summary

B3	B2	B1	B0	Symbol	Access	Description
0	0	0	0	INPUT0	read only	input register 0
0	0	0	1	INPUT1	read only	input register 1
0	0	1	0	PSC0	read/write	frequency prescaler 0
0	0	1	1	PWM0	read/write	PWM register 0
0	1	0	0	PSC1	read/write	frequency prescaler 1
0	1	0	1	PWM1	read/write	PWM register 1
0	1	1	0	LS0	read/write	LED0 to LED3 selector
0	1	1	1	LS1	read/write	LED4 to LED7 selector
1	0	0	0	LS2	read/write	LED8 to LED11 selector
1	0	0	1	LS3	read/write	LED12 to LED15 selector

## 6.3 Register descriptions

### 6.3.1 INPUT0 - Input register 0

The INPUT0 register reflects the state of the device pins (inputs 0 to 7). Writes to this register will be acknowledged but will have no effect.

Table 4. INPUT0 - Input register 0 description

Bit	7	6	5	4	3	2	1	0
Symbol	LED7	LED6	LED5	LED4	LED3	LED2	LED1	LED0
Default	X	X	X	X	X	X	X	X

**Remark:** The default value 'X' is determined by the externally applied logic level (normally logic 1) when used for directly driving LED with pull-up to  $V_{DD}$ .

### 6.3.2 INPUT1 - Input register 1

The INPUT1 register reflects the state of the device pins (inputs 8 to 15). Writes to this register will be acknowledged but will have no effect.

Table 5. INPUT1 - Input register 1 description

Bit	7	6	5	4	3	2	1	0
Symbol	LED15	LED14	LED13	LED12	LED11	LED10	LED9	LED8
Default	X	X	X	X	X	X	X	X

**Remark:** The default value 'X' is determined by the externally applied logic level (normally logic 1) when used for directly driving LED with pull-up to  $V_{DD}$ .

### 6.3.3 PCS0 - Frequency Prescaler 0

PSC0 is used to program the period of the PWM output.

The period of BLINK0 = (PSC0 + 1) / 152.

**Table 6. PSC0 - Frequency Prescaler 0 register description**

Bit	7	6	5	4	3	2	1	0
Symbol	PSC0[7]	PSC0[6]	PSC0[5]	PSC0[4]	PSC0[3]	PSC0[2]	PSC0[1]	PSC0[0]
Default	0	0	0	0	0	0	0	0

### 6.3.4 PWM0 - Pulse Width Modulation 0

The PWM0 register determines the duty cycle of BLINK0. The outputs are LOW (LED on) when the count is less than the value in PWM0 and HIGH (LED off) when it is greater. If PWM0 is programmed with 00h, then the PWM0 output is always HIGH (LED off).

The duty cycle of BLINK0 = PWM0 / 256.

**Table 7. PWM0 - Pulse Width Modulation 0 register description**

Bit	7	6	5	4	3	2	1	0
Symbol	PWM0 [7]	PWM0 [6]	PWM0 [5]	PWM0 [4]	PWM0 [3]	PWM0 [2]	PWM0 [1]	PWM0 [0]
Default	1	0	0	0	0	0	0	0

### 6.3.5 PCS1 - Frequency Prescaler 1

PSC1 is used to program the period of the PWM output.

The period of BLINK1 = (PSC1 + 1) / 152.

**Table 8. PSC1 - Frequency Prescaler 1 register description**

Bit	7	6	5	4	3	2	1	0
Symbol	PSC1[7]	PSC1[6]	PSC1[5]	PSC1[4]	PSC1[3]	PSC1[2]	PSC1[1]	PSC1[0]
Default	0	0	0	0	0	0	0	0

### 6.3.6 PWM1 - Pulse Width Modulation 1

The PWM1 register determines the duty cycle of BLINK1. The outputs are LOW (LED on) when the count is less than the value in PWM1 and HIGH (LED off) when it is greater. If PWM1 is programmed with 00h, then the PWM1 output is always HIGH (LED off).

The duty cycle of BLINK1 = PWM1 / 256.

**Table 9. PWM1 - Pulse Width Modulation 1 register description**

Bit	7	6	5	4	3	2	1	0
Symbol	PWM1 [7]	PWM1 [6]	PWM1 [5]	PWM1 [4]	PWM1 [3]	PWM1 [2]	PWM1 [1]	PWM1 [0]
Default	1	0	0	0	0	0	0	0

### 6.3.7 LS0 to LS3 - LED selector registers

The LS<sub>n</sub> LED selector registers determine the source of the LED data.

00 = output is set high-impedance (LED off; default)

01 = output is set LOW (LED on)

10 = output blinks at PWM0 rate

11 = output blinks at PWM1 rate

**Table 10. LS0 to LS3 - LED selector registers bit description**

Legend: \* default value.

Register	Bit	Value	Description
<b>LS0 - LED0 to LED3 selector</b>			
LS0	7:6	00*	LED3 selected
	5:4	00*	LED2 selected
	3:2	00*	LED1 selected
	1:0	00*	LED0 selected
<b>LS1 - LED4 to LED7 selector</b>			
LS1	7:6	00*	LED7 selected
	5:4	00*	LED6 selected
	3:2	00*	LED5 selected
	1:0	00*	LED4 selected
<b>LS2 - LED8 to LED11 selector</b>			
LS2	7:6	00*	LED11 selected
	5:4	00*	LED10 selected
	3:2	00*	LED9 selected
	1:0	00*	LED8 selected
<b>LS3 - LED12 to LED15 selector</b>			
LS3	7:6	00*	LED15 selected
	5:4	00*	LED14 selected
	3:2	00*	LED13 selected
	1:0	00*	LED12 selected



## 6.4 Pins used as GPIOs

LEDn pins not used to control LEDs can be used as General Purpose I/Os (GPIOs).

For use as input, set LEDn to high-impedance (00) and then read the pin state via the INPUT0 or INPUT1 register.

For use as output, connect external pull-up resistor to the pin and size it according to the DC recommended operating characteristics. LEDn output pin is HIGH when the output is programmed as high-impedance, and LOW when the output is programmed LOW through the 'LED selector' register. The output can be pulse-width controlled when PWM0 or PWM1 are used.

## 6.5 Power-on reset

When power is applied to  $V_{DD}$ , an internal Power-On Reset (POR) holds the PCA9532 in a reset condition until  $V_{DD}$  has reached  $V_{POR}$ . At that point, the reset condition is released and the PCA9532 registers are initialized to their default states, all the outputs in the OFF state. Thereafter,  $V_{DD}$  must be lowered below 0.2 V to reset the device.

## 6.6 External $\overline{\text{RESET}}$

A reset can be accomplished by holding the  $\overline{\text{RESET}}$  pin LOW for a minimum of  $t_{w(\text{rst})}$ . The PCA9532 registers and I<sup>2</sup>C-bus state machine will be held in their default states until the  $\overline{\text{RESET}}$  input is once again HIGH.

This input requires a pull-up resistor to  $V_{DD}$  if no active connection is used.

## 7. Characteristics of the I<sup>2</sup>C-bus

The I<sup>2</sup>C-bus is for 2-way, 2-line communication between different ICs or modules. The two lines are a serial data line (SDA) and a serial clock line (SCL). Both lines must be connected to a positive supply via a pull-up resistor when connected to the output stages of a device. Data transfer may be initiated only when the bus is not busy.

### 7.1 Bit transfer

One data bit is transferred during each clock pulse. The data on the SDA line must remain stable during the HIGH period of the clock pulse as changes in the data line at this time will be interpreted as control signals (see [Figure 7](#)).

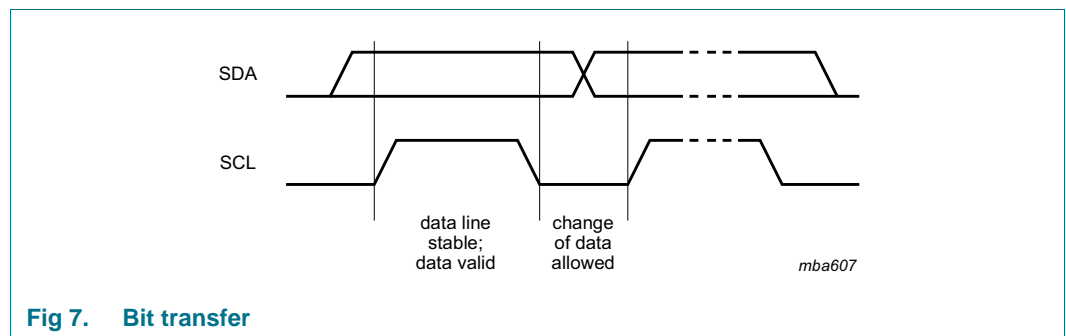

Fig 7. Bit transfer

#### 7.1.1 START and STOP conditions

Both data and clock lines remain HIGH when the bus is not busy. A HIGH-to-LOW transition of the data line while the clock is HIGH is defined as the START condition (S). A LOW-to-HIGH transition of the data line while the clock is HIGH is defined as the STOP condition (P) (see [Figure 8](#)).

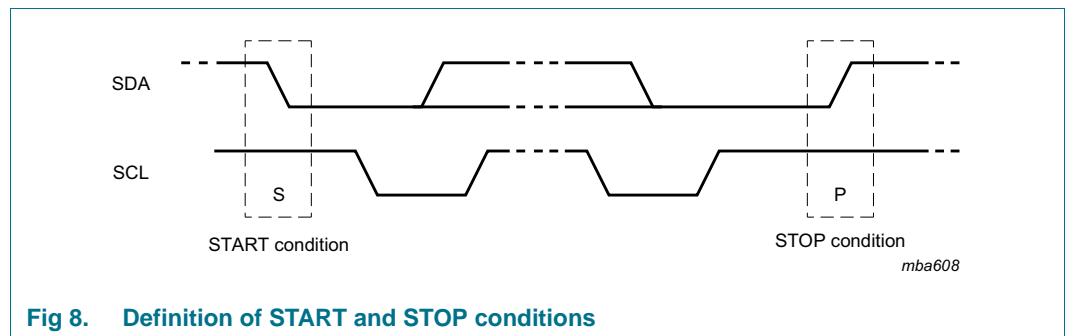

Fig 8. Definition of START and STOP conditions

### 7.2 System configuration

A device generating a message is a 'transmitter'; a device receiving is the 'receiver'. The device that controls the message is the 'master' and the devices which are controlled by the master are the 'slaves' (see [Figure 9](#)).

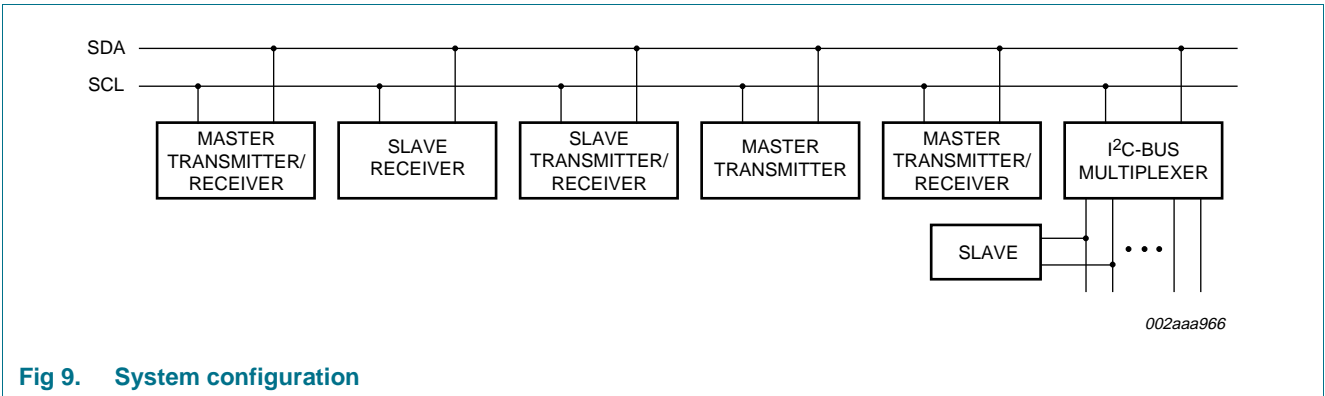

Fig 9. System configuration

### 7.3 Acknowledge

The number of data bytes transferred between the START and the STOP conditions from transmitter to receiver is not limited. Each byte of eight bits is followed by one acknowledge bit. The acknowledge bit is a HIGH level put on the bus by the transmitter, whereas the master generates an extra acknowledge related clock pulse.

A slave receiver which is addressed must generate an acknowledge after the reception of each byte. Also a master must generate an acknowledge after the reception of each byte that has been clocked out of the slave transmitter. The device that acknowledges has to pull down the SDA line during the acknowledge clock pulse, so that the SDA line is stable LOW during the HIGH period of the acknowledge related clock pulse; set-up and hold times must be taken into account.

A master receiver must signal an end of data to the transmitter by not generating an acknowledge on the last byte that has been clocked out of the slave. In this event, the transmitter must leave the data line HIGH to enable the master to generate a STOP condition.

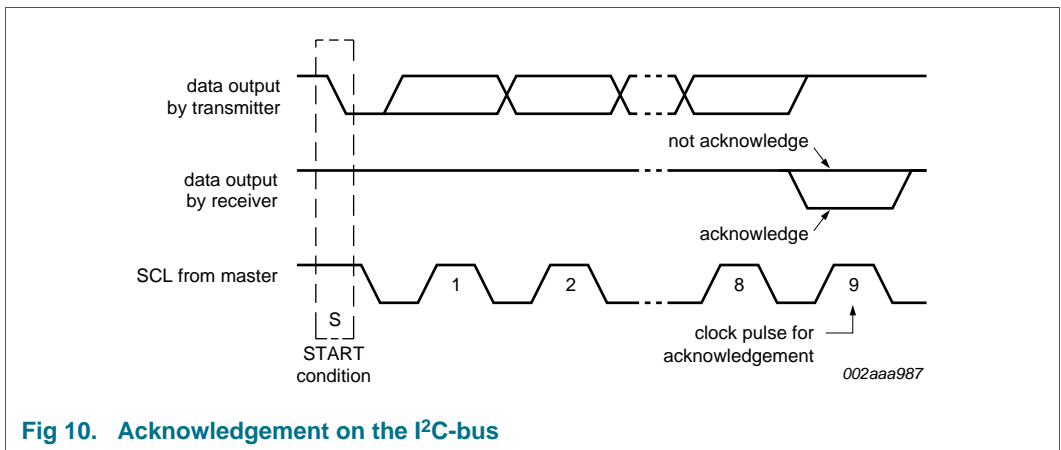

Fig 10. Acknowledgement on the I<sup>2</sup>C-bus

7.4 Bus transactions

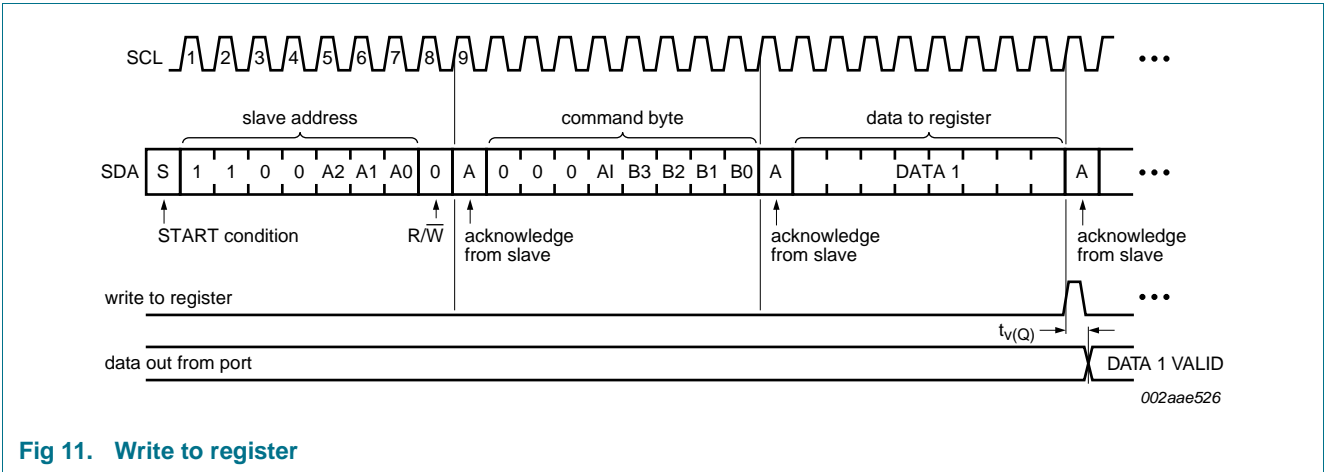

Fig 11. Write to register

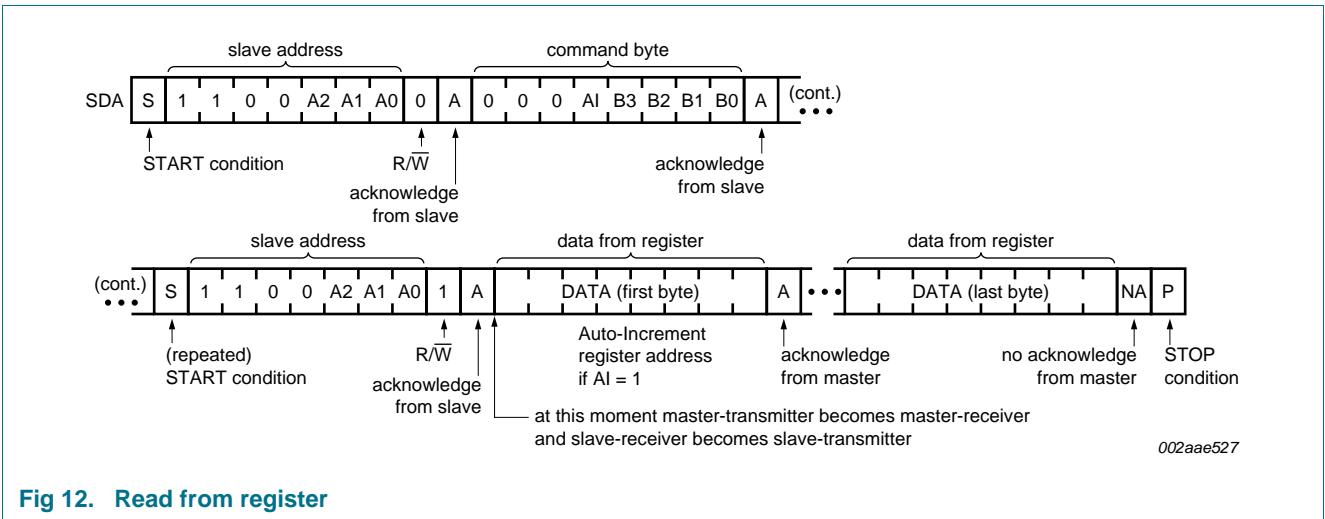
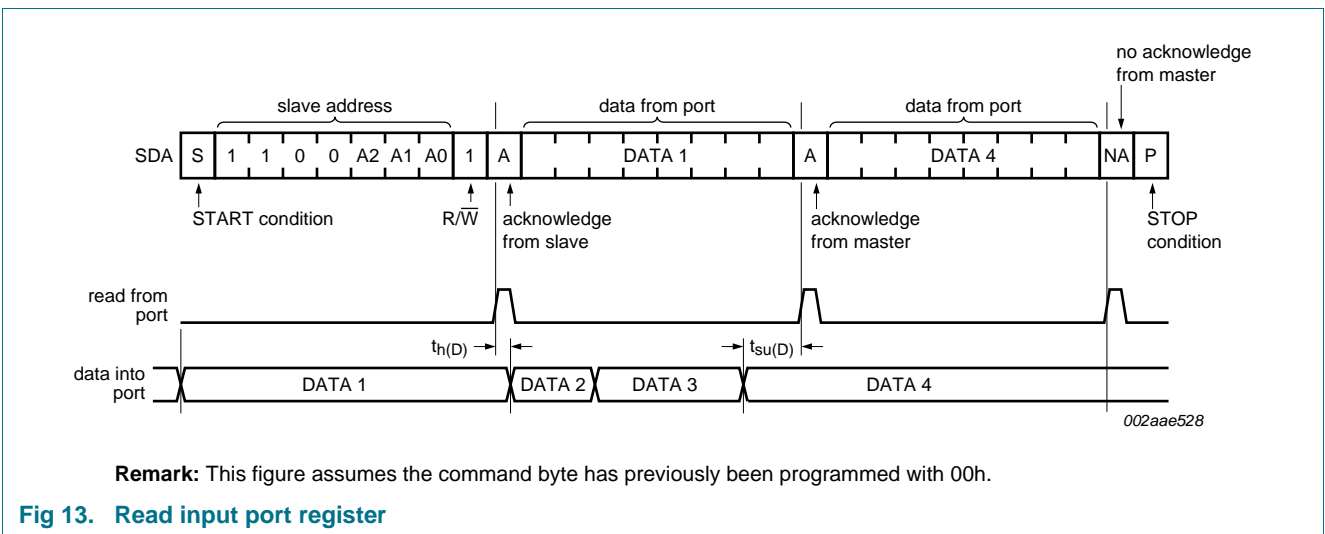

Fig 12. Read from register



Remark: This figure assumes the command byte has previously been programmed with 00h.

Fig 13. Read input port register

## 8. Application design-in information

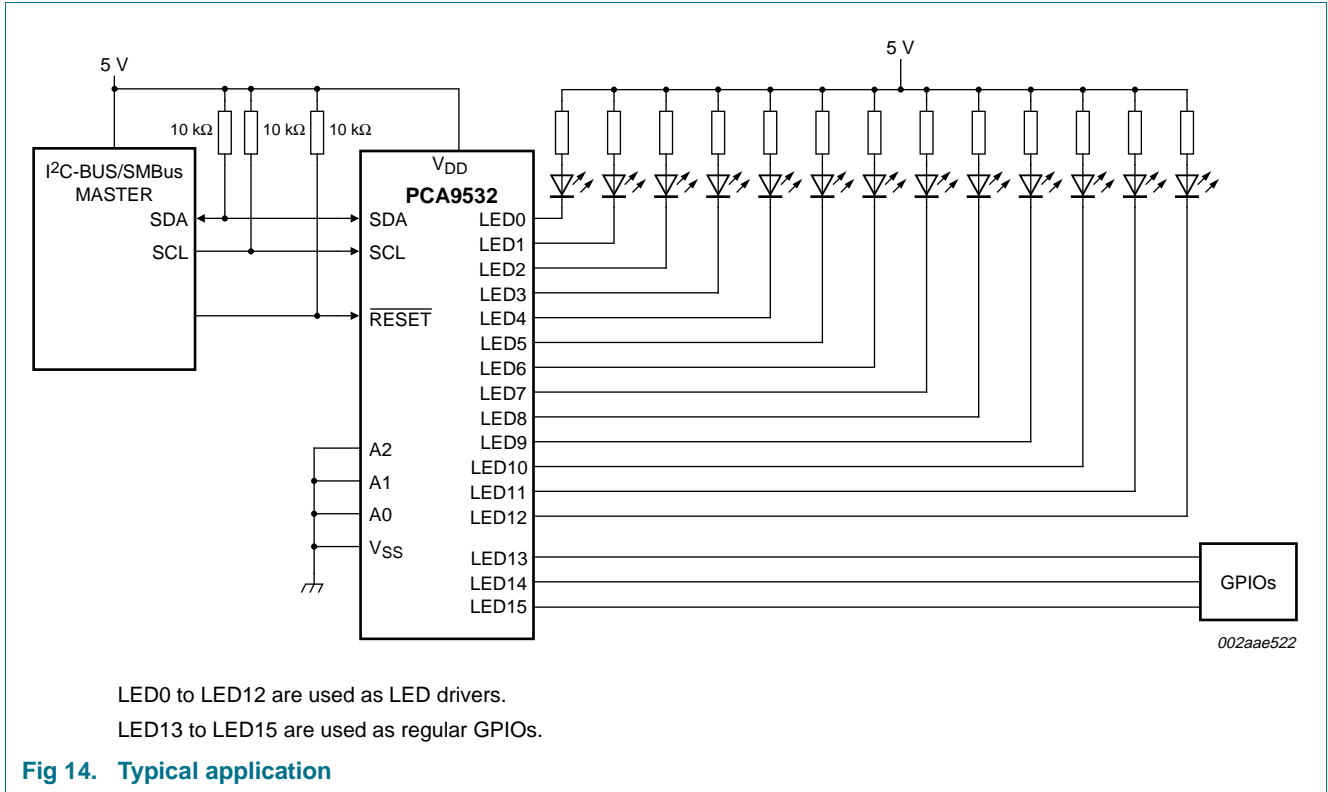

### 8.1 Minimizing I<sub>DD</sub> when the I/Os are used to control LEDs

When the I/Os are used to control LEDs, they are normally connected to V<sub>DD</sub> through a resistor as shown in [Figure 14](#). Since the LED acts as a diode, when the LED is off the I/O V<sub>I</sub> is about 1.2 V less than V<sub>DD</sub>. The supply current, I<sub>DD</sub>, increases as V<sub>I</sub> becomes lower than V<sub>DD</sub> and is specified as ΔI<sub>DD</sub> in [Table 13 “Static characteristics”](#).

Designs needing to minimize current consumption, such as battery power applications, should consider maintaining the I/O pins greater than or equal to V<sub>DD</sub> when the LED is off. [Figure 15](#) shows a high value resistor in parallel with the LED. [Figure 16](#) shows V<sub>DD</sub> less than the LED supply voltage by at least 1.2 V. Both of these methods maintain the I/O V<sub>I</sub> at or above V<sub>DD</sub> and prevents additional supply current consumption when the LED is off.

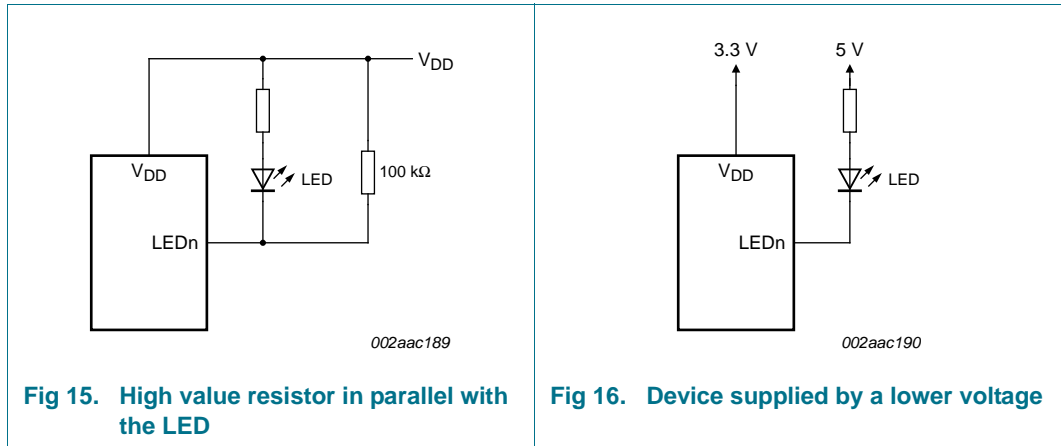

### 8.2 Programming example

The following example will show how to set LED0 to LED3 on. It will then set LED4 and LED5 to blink at 1 Hz at a 50 % duty cycle. LED6 and LED7 will be set to be dimmed at 25 % of their maximum brightness (duty cycle = 25 %). LED8 to LED15 will be set to off.

Table 11. Programming PCA9532

Program sequence	I <sup>2</sup> C-bus
START	S
PCA9532 address with A0 to A2 = LOW	C0h
PSC0 subaddress + Auto-Increment	12h
Set prescaler PSC0 to achieve a period of 1 second: $\text{Blink period} = 1 = \frac{\text{PSC0} + 1}{152}$	97h
PSC0 = 151	
Set PWM0 duty cycle to 50 %: $\frac{\text{PWM0}}{256} = 0.5$	80h
PWM0 = 128	
Set prescaler PCS1 to dim at maximum frequency: $\text{Blink period} = \text{max}$	00h
PSC1 = 0	
Set PWM1 output duty cycle to 25 %: $\frac{\text{PWM1}}{256} = 0.25$	40h
PWM1 = 64	
Set LED0 to LED3 on	55h
Set LED4 and LED5 to PWM0, and LED6 or LED7 to PWM1	FAh
Set LED8 to LED11 off	00h
Set LED12 to LED15 off	00h
STOP	P

## 9. Limiting values

**Table 12. Limiting values**

*In accordance with the Absolute Maximum Rating System (IEC 60134).*

Symbol	Parameter	Conditions	Min	Max	Unit
V <sub>DD</sub>	supply voltage		-0.5	+6.0	V
V <sub>I/O</sub>	voltage on an input/output pin		V <sub>SS</sub> - 0.5	5.5	V
I <sub>O(LEDn)</sub>	output current on pin LEDn		-	±25	mA
I <sub>SS</sub>	ground supply current		-	200	mA
P <sub>tot</sub>	total power dissipation		-	400	mW
T <sub>stg</sub>	storage temperature		-65	+150	°C
T <sub>amb</sub>	ambient temperature	operating	-40	+85	°C

## 10. Static characteristics

**Table 13. Static characteristics**

$V_{DD} = 2.3\text{ V to }5.5\text{ V}$ ;  $V_{SS} = 0\text{ V}$ ;  $T_{amb} = -40\text{ °C to }+85\text{ °C}$ ; unless otherwise specified.

Symbol	Parameter	Conditions	Min	Typ <sup>[1]</sup>	Max	Unit
<b>Supplies</b>						
$V_{DD}$	supply voltage		2.3	-	5.5	V
$I_{DD}$	supply current	operating mode; $V_{DD} = 5.5\text{ V}$ ; no load; $V_I = V_{DD}$ or $V_{SS}$ ; $f_{SCL} = 100\text{ kHz}$	-	350	550	$\mu\text{A}$
$I_{stb}$	standby current	Standby mode; $V_{DD} = 5.5\text{ V}$ ; no load; $V_I = V_{DD}$ or $V_{SS}$ ; $f_{SCL} = 0\text{ kHz}$	-	2.1	5.0	$\mu\text{A}$
$\Delta I_{DD}$	additional quiescent supply current	Standby mode; $V_{DD} = 5.5\text{ V}$ ; every LED I/O at $V_I = 4.3\text{ V}$ ; $f_{SCL} = 0\text{ kHz}$	-	-	2	mA
$V_{POR}$	power-on reset voltage	$V_{DD} = 3.3\text{ V}$ ; no load; $V_I = V_{DD}$ or $V_{SS}$	<sup>[2]</sup> -	1.7	2.2	V
<b>Input SCL; input/output SDA</b>						
$V_{IL}$	LOW-level input voltage		-0.5	-	+0.3 $V_{DD}$	V
$V_{IH}$	HIGH-level input voltage		0.7 $V_{DD}$	-	5.5	V
$I_{OL}$	LOW-level output current	$V_{OL} = 0.4\text{ V}$	3	6.5	-	mA
$I_L$	leakage current	$V_I = V_{DD} = V_{SS}$	-1	-	+1	$\mu\text{A}$
$C_i$	input capacitance	$V_I = V_{SS}$	-	4.4	5	pF
<b>I/Os</b>						
$V_{IL}$	LOW-level input voltage		-0.5	-	+0.8	V
$V_{IH}$	HIGH-level input voltage		2.0	-	5.5	V
$I_{OL}$	LOW-level output current	$V_{OL} = 0.4\text{ V}$				
		$V_{DD} = 2.3\text{ V}$	<sup>[3]</sup> 9	-	-	mA
		$V_{DD} = 3.0\text{ V}$	<sup>[3]</sup> 12	-	-	mA
		$V_{DD} = 5.0\text{ V}$	<sup>[3]</sup> 15	-	-	mA
		$V_{OL} = 0.7\text{ V}$				
		$V_{DD} = 2.3\text{ V}$	<sup>[3]</sup> 15	-	-	mA
		$V_{DD} = 3.0\text{ V}$	<sup>[3]</sup> 20	-	-	mA
$V_{DD} = 5.0\text{ V}$	<sup>[3]</sup> 25	-	-	mA		
$I_{LI}$	input leakage current	$V_{DD} = 3.6\text{ V}$ ; $V_I = 0\text{ V}$ or $V_{DD}$	-1	-	+1	$\mu\text{A}$
$C_{io}$	input/output capacitance		-	2.6	5	pF
<b>Select inputs A0, A1, A2; RESET</b>						
$V_{IL}$	LOW-level input voltage		-0.5	-	+0.8	V
$V_{IH}$	HIGH-level input voltage		2.0	-	5.5	V
$I_{LI}$	input leakage current		-1	-	+1	$\mu\text{A}$
$C_i$	input capacitance	$V_I = V_{SS}$	-	2.3	5	pF

[1] Typical limits at  $V_{DD} = 3.3\text{ V}$ ,  $T_{amb} = 25\text{ °C}$ .

[2]  $V_{DD}$  must be lowered to 0.2 V in order to reset part.

[3] Each I/O must be externally limited to a maximum of 25 mA and each octal ([LED0 to LED7] and [LED8 to LED15]) must be limited to a maximum current of 100 mA for a device total of 200 mA.



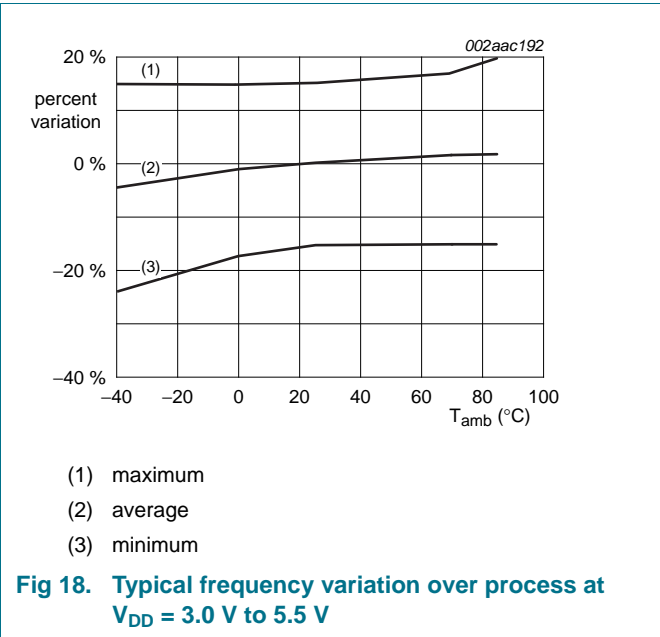
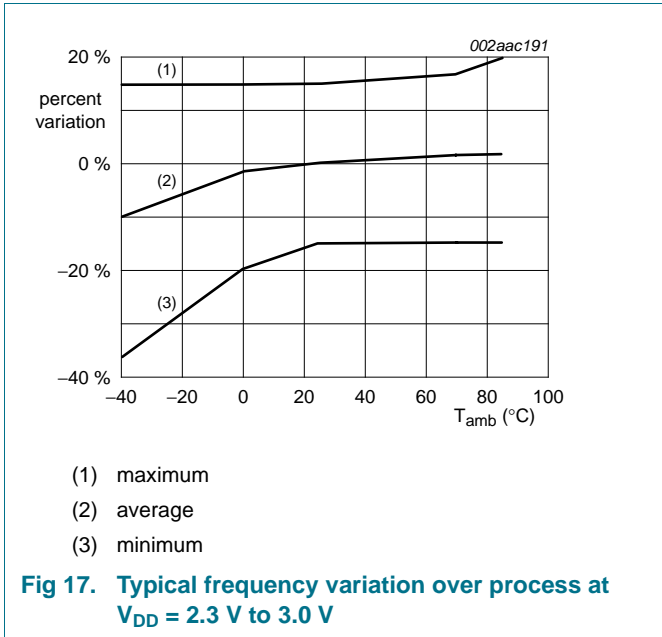

## 11. Dynamic characteristics

Table 14. Dynamic characteristics

Symbol	Parameter	Conditions	Standard-mode I <sup>2</sup> C-bus		Fast-mode I <sup>2</sup> C-bus		Unit
			Min	Max	Min	Max	
f <sub>SCL</sub>	SCL clock frequency		0	100	0	400	kHz
t <sub>BUF</sub>	bus free time between a STOP and START condition		4.7	-	1.3	-	μs
t <sub>HD;STA</sub>	hold time (repeated) START condition		4.0	-	0.6	-	μs
t <sub>SU;STA</sub>	set-up time for a repeated START condition		4.7	-	0.6	-	μs
t <sub>SU;STO</sub>	set-up time for STOP condition		4.0	-	0.6	-	μs
t <sub>HD;DAT</sub>	data hold time		0	-	0	-	ns
t <sub>VD;ACK</sub>	data valid acknowledge time		[1]	-	600	-	600 ns
t <sub>VD;DAT</sub>	data valid time	LOW-level	[2]	-	600	-	600 ns
		HIGH-level	[2]	-	1500	-	600 ns
t <sub>SU;DAT</sub>	data set-up time		250	-	100	-	ns
t <sub>LOW</sub>	LOW period of the SCL clock		4.7	-	1.3	-	μs
t <sub>HIGH</sub>	HIGH period of the SCL clock		4.0	-	0.6	-	μs
t <sub>r</sub>	rise time of both SDA and SCL signals		-	1000	20 + 0.1C <sub>b</sub> [3]	300	ns
t <sub>f</sub>	fall time of both SDA and SCL signals		-	300	20 + 0.1C <sub>b</sub> [3]	300	ns
t <sub>SP</sub>	pulse width of spikes that must be suppressed by the input filter		-	50	-	50	ns
<b>Port timing</b>							
t <sub>V(Q)</sub>	data output valid time		-	200	-	200	ns
t <sub>SU(D)</sub>	data input set-up time		100	-	100	-	ns
t <sub>H(D)</sub>	data input hold time		1	-	1	-	μs
<b>Reset</b>							
t <sub>w(rst)</sub>	reset pulse width		10	-	10	-	ns
t <sub>rec(rst)</sub>	reset recovery time		0	-	0	-	ns
t <sub>rst</sub>	reset time		[4][5]	400	-	400	ns

[1] t<sub>VD;ACK</sub> = time for Acknowledgement signal from SCL LOW to SDA (out) LOW.

[2] t<sub>VD;DAT</sub> = minimum time for SDA data output to be valid following SCL LOW.

[3] C<sub>b</sub> = total capacitance of one bus line in pF.

[4] Resetting the device while actively communicating on the bus may cause glitches or errant STOP conditions.

[5] Upon reset, the full delay will be the sum of t<sub>rst</sub> and the RC time constant of the SDA bus.

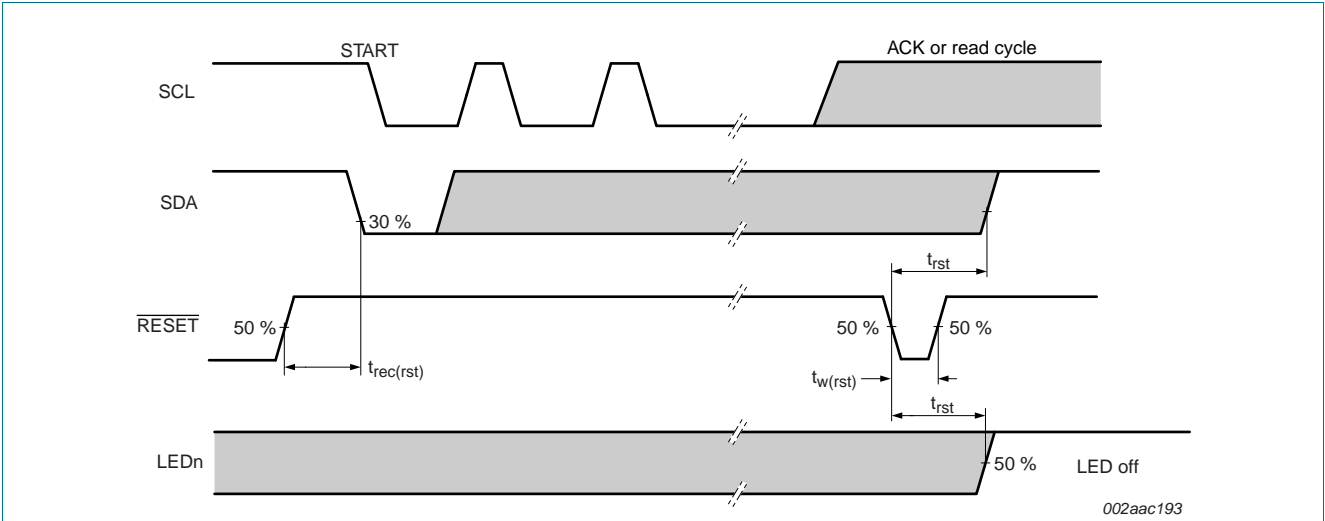

Fig 19. Definition of RESET timing

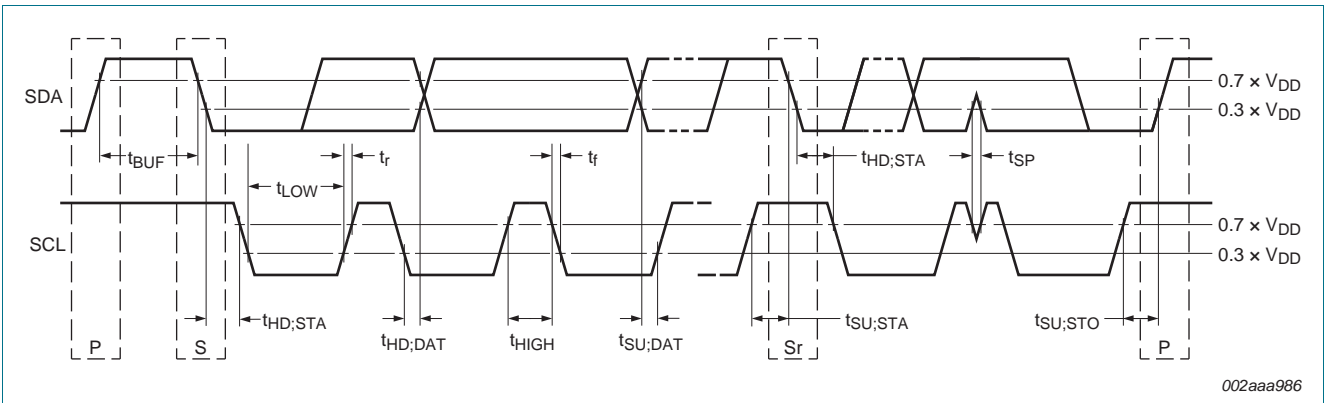

Fig 20. Definition of timing

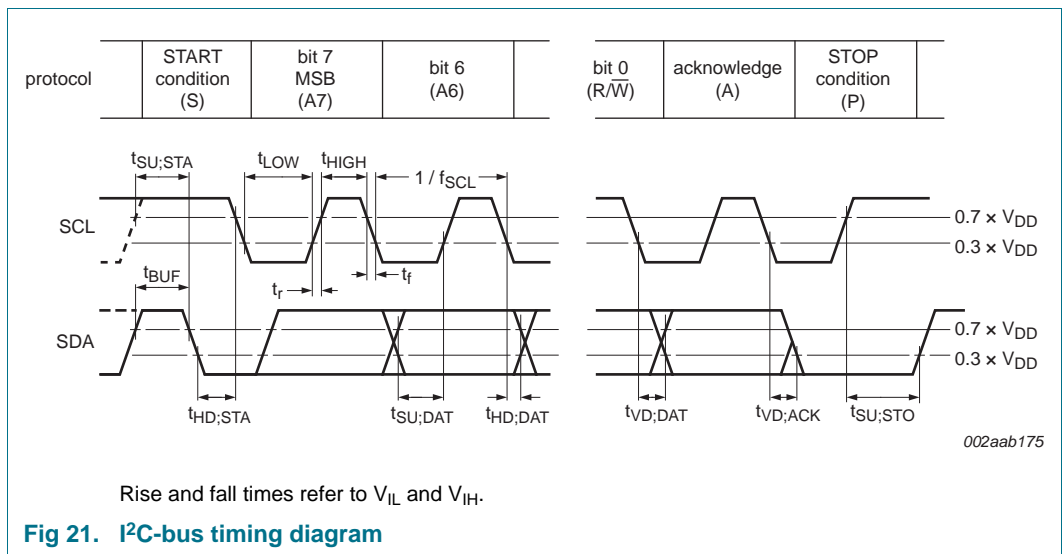
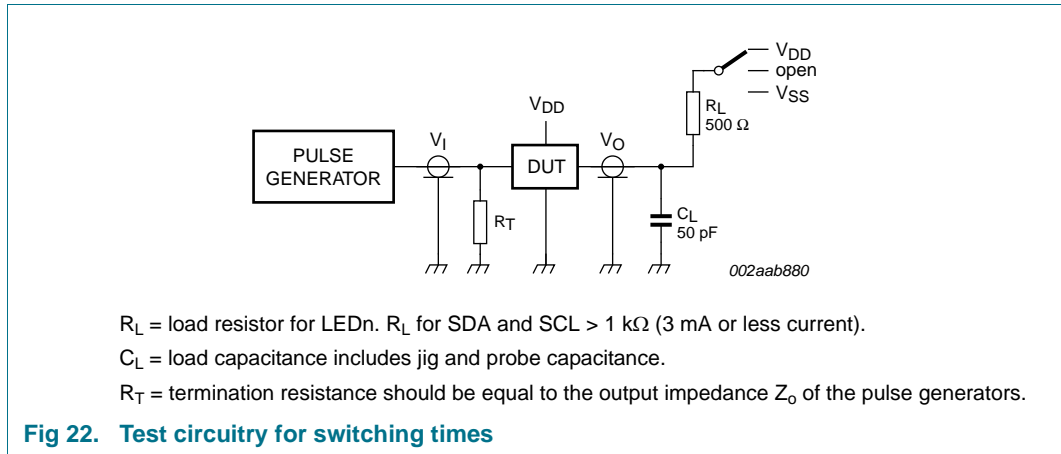

Fig 21. I<sup>2</sup>C-bus timing diagram

12. Test information



13. Package outline

SO24: plastic small outline package; 24 leads; body width 7.5 mm

SOT137-1

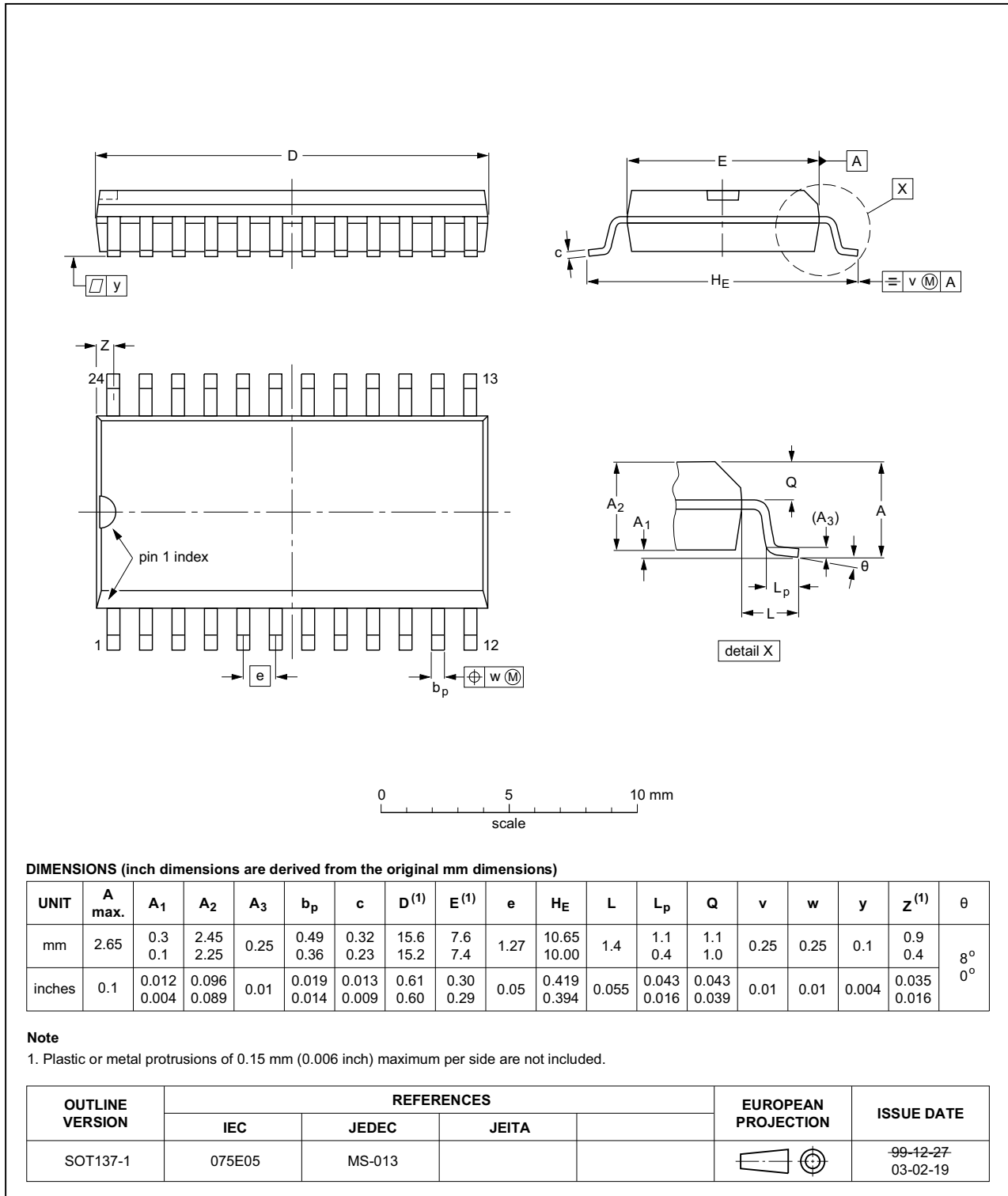

Fig 23. Package outline SOT137-1 (SO24)

TSSOP24: plastic thin shrink small outline package; 24 leads; body width 4.4 mm

SOT355-1

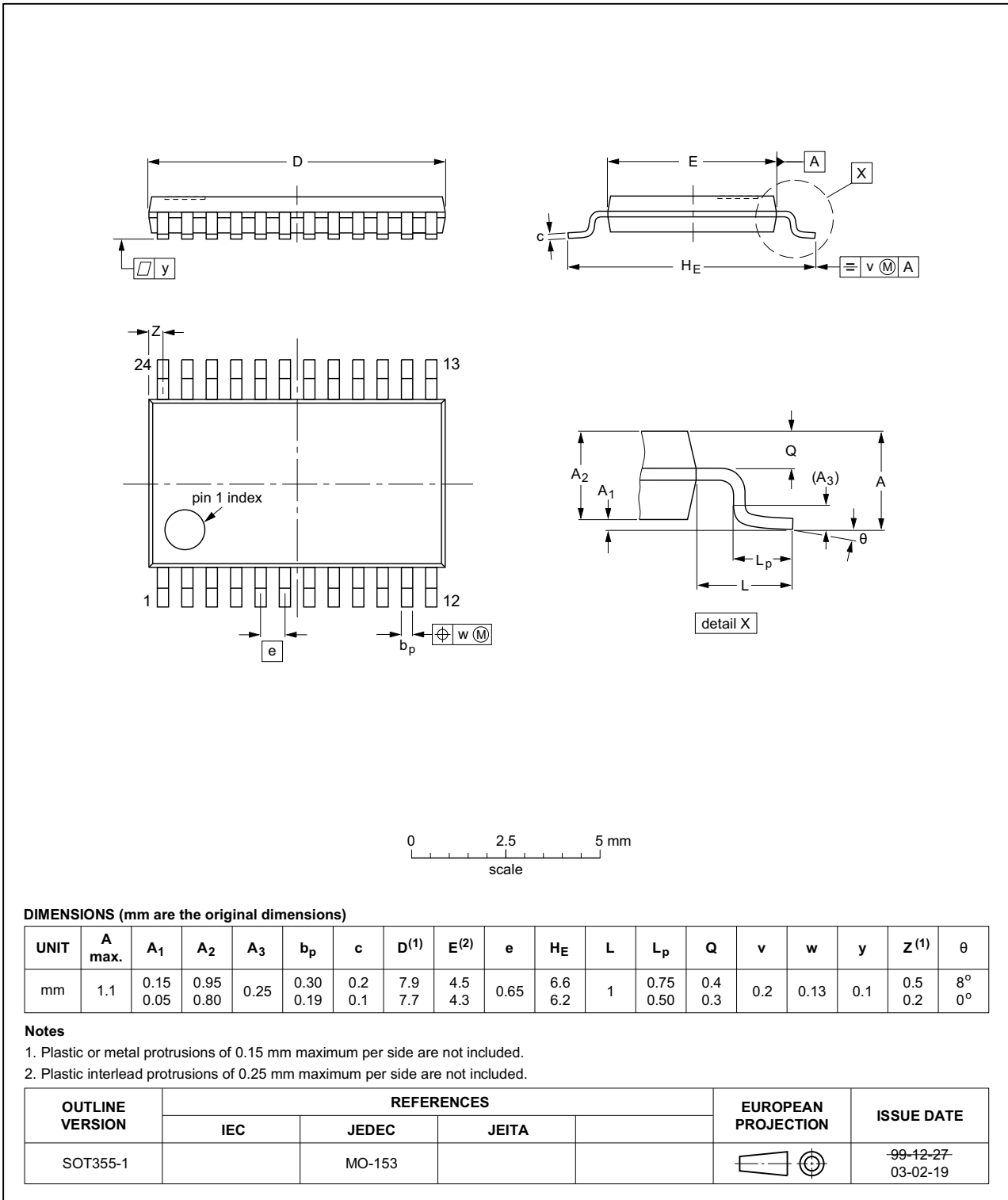

Fig 24. Package outline SOT355-1 (TSSOP24)

HVQFN24: plastic thermal enhanced very thin quad flat package; no leads;  
24 terminals; body 4 x 4 x 0.85 mm

SOT616-1

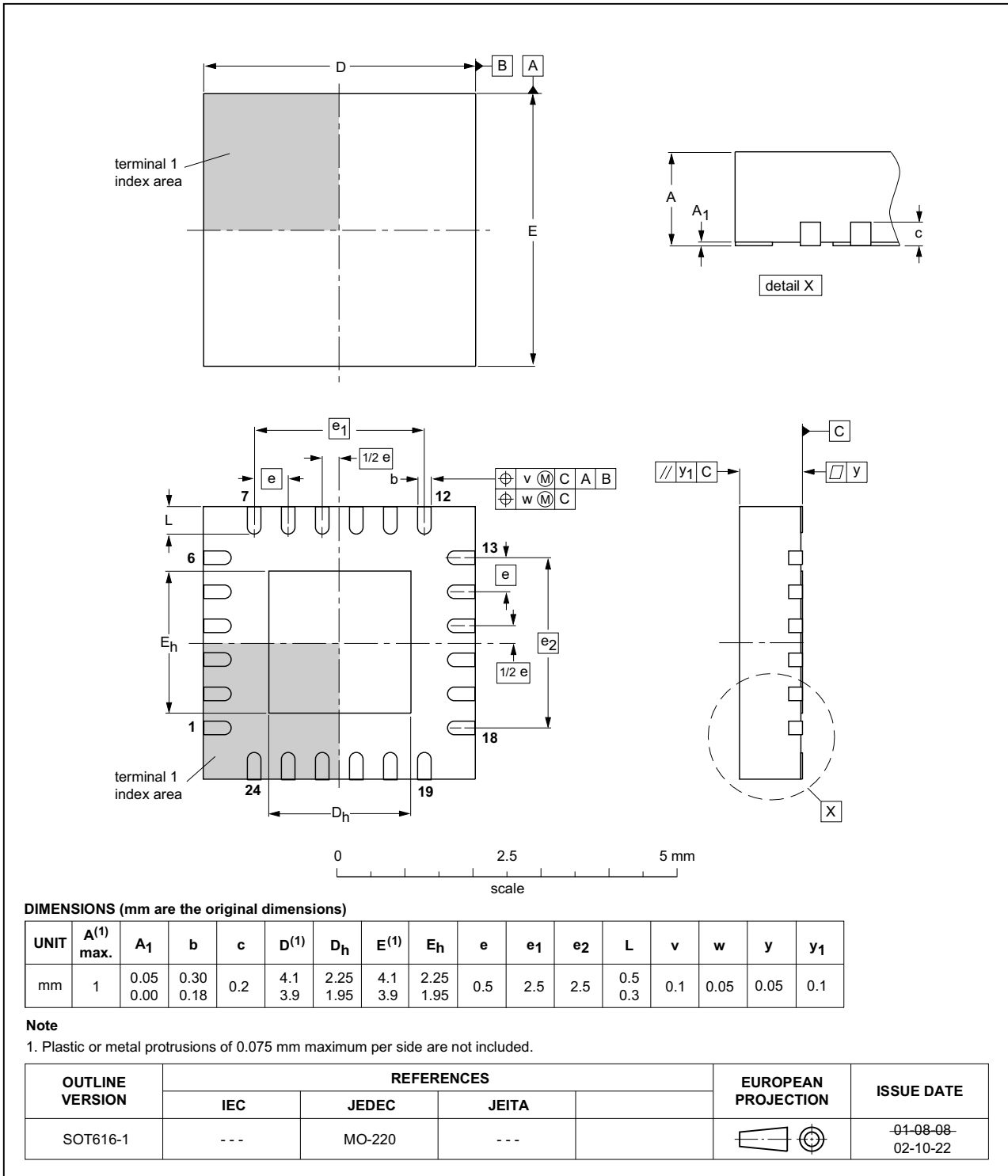

Fig 25. Package outline SOT616-1 (HVQFN24)

## 14. Handling information

All input and output pins are protected against ElectroStatic Discharge (ESD) under normal handling. When handling ensure that the appropriate precautions are taken as described in *JESD625-A* or equivalent standards.

## 15. Soldering of SMD packages

This text provides a very brief insight into a complex technology. A more in-depth account of soldering ICs can be found in Application Note *AN10365 "Surface mount reflow soldering description"*.

### 15.1 Introduction to soldering

Soldering is one of the most common methods through which packages are attached to Printed Circuit Boards (PCBs), to form electrical circuits. The soldered joint provides both the mechanical and the electrical connection. There is no single soldering method that is ideal for all IC packages. Wave soldering is often preferred when through-hole and Surface Mount Devices (SMDs) are mixed on one printed wiring board; however, it is not suitable for fine pitch SMDs. Reflow soldering is ideal for the small pitches and high densities that come with increased miniaturization.

### 15.2 Wave and reflow soldering

Wave soldering is a joining technology in which the joints are made by solder coming from a standing wave of liquid solder. The wave soldering process is suitable for the following:

- Through-hole components
- Leaded or leadless SMDs, which are glued to the surface of the printed circuit board

Not all SMDs can be wave soldered. Packages with solder balls, and some leadless packages which have solder lands underneath the body, cannot be wave soldered. Also, leaded SMDs with leads having a pitch smaller than ~0.6 mm cannot be wave soldered, due to an increased probability of bridging.

The reflow soldering process involves applying solder paste to a board, followed by component placement and exposure to a temperature profile. Leaded packages, packages with solder balls, and leadless packages are all reflow solderable.

Key characteristics in both wave and reflow soldering are:

- Board specifications, including the board finish, solder masks and vias
- Package footprints, including solder thieves and orientation
- The moisture sensitivity level of the packages
- Package placement
- Inspection and repair
- Lead-free soldering versus SnPb soldering

### 15.3 Wave soldering

Key characteristics in wave soldering are:



- Process issues, such as application of adhesive and flux, clinching of leads, board transport, the solder wave parameters, and the time during which components are exposed to the wave
- Solder bath specifications, including temperature and impurities

### 15.4 Reflow soldering

Key characteristics in reflow soldering are:

- Lead-free versus SnPb soldering; note that a lead-free reflow process usually leads to higher minimum peak temperatures (see [Figure 26](#)) than a SnPb process, thus reducing the process window
- Solder paste printing issues including smearing, release, and adjusting the process window for a mix of large and small components on one board
- Reflow temperature profile; this profile includes preheat, reflow (in which the board is heated to the peak temperature) and cooling down. It is imperative that the peak temperature is high enough for the solder to make reliable solder joints (a solder paste characteristic). In addition, the peak temperature must be low enough that the packages and/or boards are not damaged. The peak temperature of the package depends on package thickness and volume and is classified in accordance with [Table 15](#) and [16](#)

**Table 15. SnPb eutectic process (from J-STD-020D)**

Package thickness (mm)	Package reflow temperature (°C)	
	Volume (mm <sup>3</sup> )	
	< 350	≥ 350
< 2.5	235	220
≥ 2.5	220	220

**Table 16. Lead-free process (from J-STD-020D)**

Package thickness (mm)	Package reflow temperature (°C)		
	Volume (mm <sup>3</sup> )		
	< 350	350 to 2000	> 2000
< 1.6	260	260	260
1.6 to 2.5	260	250	245
> 2.5	250	245	245

Moisture sensitivity precautions, as indicated on the packing, must be respected at all times.

Studies have shown that small packages reach higher temperatures during reflow soldering, see [Figure 26](#).

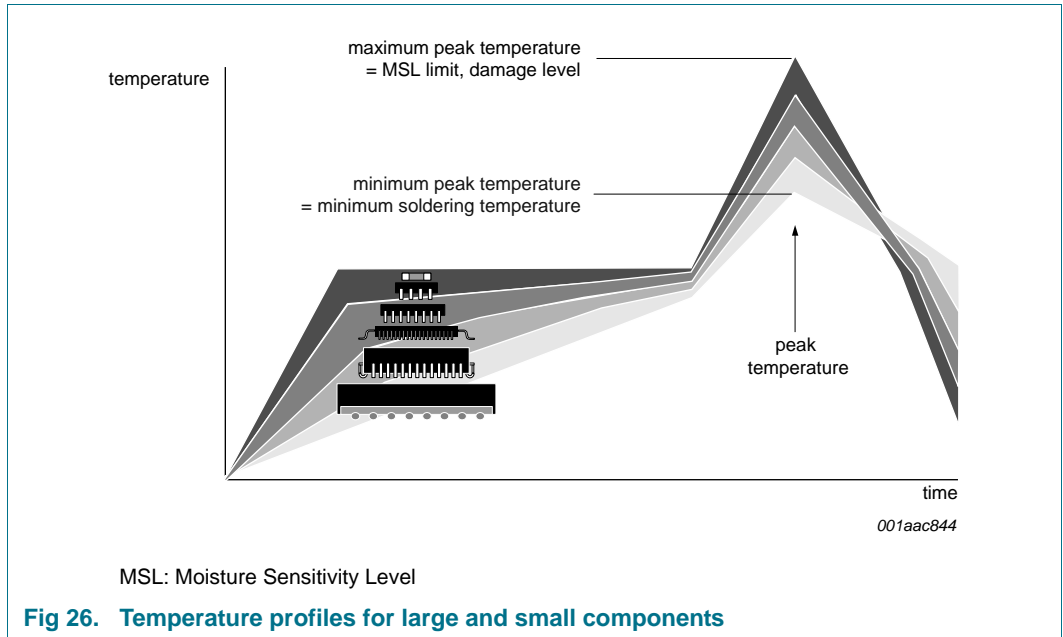

For further information on temperature profiles, refer to Application Note AN10365 “Surface mount reflow soldering description”.

## 16. Abbreviations

**Table 17. Abbreviations**

Acronym	Description
ACPI	Advanced Configuration and Power Interface
CDM	Charged Device Model
DSP	Digital Signal Processor
DUT	Device Under Test
ESD	ElectroStatic Discharge
GPIO	General Purpose Input/Output
HBM	Human Body Model
I <sup>2</sup> C-bus	Inter-Integrated Circuit bus
LED	Light Emitting Diode
MCU	MicroController Unit
MM	Machine Model
MPU	MicroProcessor Unit
POR	Power-On Reset
RC	Resistor-Capacitor network
SMBus	System Management Bus

## 17. Revision history

Table 18. Revision history

Document ID	Release date	Data sheet status	Change notice	Supersedes
PCA9532 v.4.1	20160822	Product data sheet	-	PCA9532_4
Modifications:	<ul style="list-style-type: none"> <li>• <a href="#">Table 1</a>: Corrected topside mark for PCA9532PW.</li> </ul>			
PCA9532_4	20090317	Product data sheet	-	PCA9532_3
Modifications:	<ul style="list-style-type: none"> <li>• The format of this data sheet has been redesigned to comply with the new identity guidelines of NXP Semiconductors.</li> <li>• Legal texts have been adapted to the new company name where appropriate.</li> <li>• <a href="#">Section 5.1 "Pinning"</a>: replaced (old) Figure 1 with separate drawings for SO24 (<a href="#">Figure 2</a>) and TSSOP24 (<a href="#">Figure 3</a>)</li> <li>• <a href="#">Table 2 "Pin description"</a>: added <a href="#">Table note [1]</a> and its reference at HVQFN24 pin 9, V<sub>SS</sub></li> <li>• <a href="#">Section 6.2 "Control register"</a>: <ul style="list-style-type: none"> <li>– 2<sup>nd</sup> paragraph: changed from "The lowest 3 bits are ..." to "The lowest 4 bits are ..."</li> <li>– 4<sup>th</sup> paragraph: changed from "... by reading a register different from '0' ..." to "... by reading a register different from INPUT0 ..."</li> </ul> </li> <li>• <a href="#">Section 6.6 "External RESET"</a>, 1<sup>st</sup> paragraph, 1<sup>st</sup> sentence: changed symbol from "t<sub>w</sub>" to "t<sub>w(rst)</sub>"</li> <li>• <a href="#">Figure 11 "Write to register"</a>: symbol changed from "t<sub>pv</sub>" to "t<sub>v(Q)</sub>"</li> <li>• <a href="#">Figure 13 "Read input port register"</a>: <ul style="list-style-type: none"> <li>– Symbol changed from "t<sub>ph</sub>" to "t<sub>h(D)</sub>"</li> <li>– Symbol changed from "t<sub>ps</sub>" to "t<sub>su(D)</sub>"</li> </ul> </li> <li>• <a href="#">Table 12 "Limiting values"</a>: changed symbol/parameter from "I<sub>I/O</sub>, DC output current on an I/O" to "I<sub>O(LEDn)</sub>, output current on pin LEDn"</li> <li>• <a href="#">Table 13 "Static characteristics"</a>: <ul style="list-style-type: none"> <li>– Descriptive line below table title: 2<sup>nd</sup> sentence is moved to <a href="#">Table note [1]</a>, with its reference at column heading "Typ"</li> <li>– ΔI<sub>DD</sub> parameter changed from "additional standby current" to "additional quiescent supply current"</li> <li>– Sub-section "I/Os": symbol changed from "I<sub>L</sub>" to "I<sub>LI</sub>"</li> </ul> </li> <li>• <a href="#">Table 14 "Dynamic characteristics"</a>: <ul style="list-style-type: none"> <li>– Symbol/parameter changed from "t<sub>pV</sub>, Output data valid" to "t<sub>v(Q)</sub>, data output valid time"</li> <li>– Symbol/parameter changed from "t<sub>ps</sub>, Input data set-up time" to "t<sub>su(D)</sub>, data input set-up time"</li> <li>– Symbol/parameter changed from "t<sub>pH</sub>, Input data hold time" to "t<sub>h(D)</sub>, data input hold time"</li> <li>– Symbol changed from "t<sub>w</sub>" to "t<sub>w(rst)</sub>"</li> <li>– Symbol changed from "t<sub>REC</sub>" to "t<sub>rec(rst)</sub>"</li> <li>– Symbol/parameter changed from "t<sub>RESET</sub>, Time to reset" to "t<sub>rst</sub>, reset time"</li> </ul> </li> <li>• <a href="#">Figure 19 "Definition of RESET timing"</a>: <ul style="list-style-type: none"> <li>– Symbol changed from "t<sub>REC</sub>" to "t<sub>rec(rst)</sub>"</li> <li>– Symbol changed from "t<sub>RESET</sub>" to "t<sub>rst</sub>"</li> <li>– Symbol changed from "t<sub>w</sub>" to "t<sub>w(rst)</sub>"</li> <li>– Symbol changed from "t<sub>RESET</sub>" to "t<sub>rst</sub>"</li> </ul> </li> <li>• Updated handling information</li> <li>• Added soldering information</li> </ul>			
PCA9532_3	20041001	Product data sheet	-	PCA9532_2
PCA9532_2 (9397 750 11459)	20030502	Product data	ECN 853-2398 29860 dated 24 Apr 2003	PCA9532_1

Table 18. Revision history ...continued

Document ID	Release date	Data sheet status	Change notice	Supersedes
PCA9532_1 (9397 750 10874)	20030226	Product data	ECN 853-2398 29297 dated 12 Dec 2002	-

## 18. Legal information

### 18.1 Data sheet status

Document status <sup>[1][2]</sup>	Product status <sup>[3]</sup>	Definition
Objective [short] data sheet	Development	This document contains data from the objective specification for product development.
Preliminary [short] data sheet	Qualification	This document contains data from the preliminary specification.
Product [short] data sheet	Production	This document contains the product specification.

[1] Please consult the most recently issued document before initiating or completing a design.

[2] The term 'short data sheet' is explained in section "Definitions".

[3] The product status of device(s) described in this document may have changed since this document was published and may differ in case of multiple devices. The latest product status information is available on the Internet at URL <http://www.nxp.com>.

### 18.2 Definitions

**Draft** — The document is a draft version only. The content is still under internal review and subject to formal approval, which may result in modifications or additions. NXP Semiconductors does not give any representations or warranties as to the accuracy or completeness of information included herein and shall have no liability for the consequences of use of such information.

**Short data sheet** — A short data sheet is an extract from a full data sheet with the same product type number(s) and title. A short data sheet is intended for quick reference only and should not be relied upon to contain detailed and full information. For detailed and full information see the relevant full data sheet, which is available on request via the local NXP Semiconductors sales office. In case of any inconsistency or conflict with the short data sheet, the full data sheet shall prevail.

**Product specification** — The information and data provided in a Product data sheet shall define the specification of the product as agreed between NXP Semiconductors and its customer, unless NXP Semiconductors and customer have explicitly agreed otherwise in writing. In no event however, shall an agreement be valid in which the NXP Semiconductors product is deemed to offer functions and qualities beyond those described in the Product data sheet.

### 18.3 Disclaimers

**Limited warranty and liability** — Information in this document is believed to be accurate and reliable. However, NXP Semiconductors does not give any representations or warranties, expressed or implied, as to the accuracy or completeness of such information and shall have no liability for the consequences of use of such information. NXP Semiconductors takes no responsibility for the content in this document if provided by an information source outside of NXP Semiconductors.

In no event shall NXP Semiconductors be liable for any indirect, incidental, punitive, special or consequential damages (including - without limitation - lost profits, lost savings, business interruption, costs related to the removal or replacement of any products or rework charges) whether or not such damages are based on tort (including negligence), warranty, breach of contract or any other legal theory.

Notwithstanding any damages that customer might incur for any reason whatsoever, NXP Semiconductors' aggregate and cumulative liability towards customer for the products described herein shall be limited in accordance with the *Terms and conditions of commercial sale* of NXP Semiconductors.

**Right to make changes** — NXP Semiconductors reserves the right to make changes to information published in this document, including without limitation specifications and product descriptions, at any time and without notice. This document supersedes and replaces all information supplied prior to the publication hereof.

**Suitability for use** — NXP Semiconductors products are not designed, authorized or warranted to be suitable for use in life support, life-critical or safety-critical systems or equipment, nor in applications where failure or malfunction of an NXP Semiconductors product can reasonably be expected to result in personal injury, death or severe property or environmental damage. NXP Semiconductors and its suppliers accept no liability for inclusion and/or use of NXP Semiconductors products in such equipment or applications and therefore such inclusion and/or use is at the customer's own risk.

**Applications** — Applications that are described herein for any of these products are for illustrative purposes only. NXP Semiconductors makes no representation or warranty that such applications will be suitable for the specified use without further testing or modification.

Customers are responsible for the design and operation of their applications and products using NXP Semiconductors products, and NXP Semiconductors accepts no liability for any assistance with applications or customer product design. It is customer's sole responsibility to determine whether the NXP Semiconductors product is suitable and fit for the customer's applications and products planned, as well as for the planned application and use of customer's third party customer(s). Customers should provide appropriate design and operating safeguards to minimize the risks associated with their applications and products.

NXP Semiconductors does not accept any liability related to any default, damage, costs or problem which is based on any weakness or default in the customer's applications or products, or the application or use by customer's third party customer(s). Customer is responsible for doing all necessary testing for the customer's applications and products using NXP Semiconductors products in order to avoid a default of the applications and the products or of the application or use by customer's third party customer(s). NXP does not accept any liability in this respect.

**Limiting values** — Stress above one or more limiting values (as defined in the Absolute Maximum Ratings System of IEC 60134) will cause permanent damage to the device. Limiting values are stress ratings only and (proper) operation of the device at these or any other conditions above those given in the Recommended operating conditions section (if present) or the Characteristics sections of this document is not warranted. Constant or repeated exposure to limiting values will permanently and irreversibly affect the quality and reliability of the device.

**Terms and conditions of commercial sale** — NXP Semiconductors products are sold subject to the general terms and conditions of commercial sale, as published at <http://www.nxp.com/profile/terms>, unless otherwise agreed in a valid written individual agreement. In case an individual agreement is concluded only the terms and conditions of the respective agreement shall apply. NXP Semiconductors hereby expressly objects to applying the customer's general terms and conditions with regard to the purchase of NXP Semiconductors products by customer.

**No offer to sell or license** — Nothing in this document may be interpreted or construed as an offer to sell products that is open for acceptance or the grant, conveyance or implication of any license under any copyrights, patents or other industrial or intellectual property rights.

**Export control** — This document as well as the item(s) described herein may be subject to export control regulations. Export might require a prior authorization from competent authorities.

**Non-automotive qualified products** — Unless this data sheet expressly states that this specific NXP Semiconductors product is automotive qualified, the product is not suitable for automotive use. It is neither qualified nor tested in accordance with automotive testing or application requirements. NXP Semiconductors accepts no liability for inclusion and/or use of non-automotive qualified products in automotive equipment or applications.

In the event that customer uses the product for design-in and use in automotive applications to automotive specifications and standards, customer (a) shall use the product without NXP Semiconductors' warranty of the product for such automotive applications, use and specifications, and (b) whenever customer uses the product for automotive applications beyond NXP Semiconductors' specifications such use shall be solely at customer's

own risk, and (c) customer fully indemnifies NXP Semiconductors for any liability, damages or failed product claims resulting from customer design and use of the product for automotive applications beyond NXP Semiconductors' standard warranty and NXP Semiconductors' product specifications.

**Translations** — A non-English (translated) version of a document is for reference only. The English version shall prevail in case of any discrepancy between the translated and English versions.

## 18.4 Trademarks

Notice: All referenced brands, product names, service names and trademarks are the property of their respective owners.

**I<sup>2</sup>C-bus** — logo is a trademark of NXP Semiconductors N.V.

## 19. Contact information

For more information, please visit: <http://www.nxp.com>

For sales office addresses, please send an email to: [salesaddresses@nxp.com](mailto:salesaddresses@nxp.com)

## 20. Contents

<b>1</b>	<b>General description</b> .....	<b>1</b>	<b>18</b>	<b>Legal information</b> .....	<b>29</b>
<b>2</b>	<b>Features and benefits</b> .....	<b>1</b>	18.1	Data sheet status .....	29
<b>3</b>	<b>Ordering information</b> .....	<b>2</b>	18.2	Definitions .....	29
<b>4</b>	<b>Block diagram</b> .....	<b>2</b>	18.3	Disclaimers .....	29
<b>5</b>	<b>Pinning information</b> .....	<b>3</b>	18.4	Trademarks .....	30
5.1	Pinning .....	3	<b>19</b>	<b>Contact information</b> .....	<b>30</b>
5.2	Pin description .....	4	<b>20</b>	<b>Contents</b> .....	<b>31</b>
<b>6</b>	<b>Functional description</b> .....	<b>5</b>			
6.1	Device address .....	5			
6.2	Control register .....	5			
6.2.1	Control register definition .....	6			
6.3	Register descriptions .....	6			
6.3.1	INPUT0 - Input register 0 .....	6			
6.3.2	INPUT1 - Input register 1 .....	6			
6.3.3	PCS0 - Frequency Prescaler 0 .....	7			
6.3.4	PWM0 - Pulse Width Modulation 0 .....	7			
6.3.5	PCS1 - Frequency Prescaler 1 .....	7			
6.3.6	PWM1 - Pulse Width Modulation 1 .....	7			
6.3.7	LS0 to LS3 - LED selector registers .....	8			
6.4	Pins used as GPIOs .....	9			
6.5	Power-on reset .....	9			
6.6	External RESET .....	9			
<b>7</b>	<b>Characteristics of the I<sup>2</sup>C-bus</b> .....	<b>10</b>			
7.1	Bit transfer .....	10			
7.1.1	START and STOP conditions .....	10			
7.2	System configuration .....	10			
7.3	Acknowledge .....	11			
7.4	Bus transactions .....	12			
<b>8</b>	<b>Application design-in information</b> .....	<b>13</b>			
8.1	Minimizing I <sub>DD</sub> when the I/Os are used to control LEDs .....	13			
8.2	Programming example .....	14			
<b>9</b>	<b>Limiting values</b> .....	<b>15</b>			
<b>10</b>	<b>Static characteristics</b> .....	<b>16</b>			
<b>11</b>	<b>Dynamic characteristics</b> .....	<b>18</b>			
<b>12</b>	<b>Test information</b> .....	<b>20</b>			
<b>13</b>	<b>Package outline</b> .....	<b>21</b>			
<b>14</b>	<b>Handling information</b> .....	<b>24</b>			
<b>15</b>	<b>Soldering of SMD packages</b> .....	<b>24</b>			
15.1	Introduction to soldering .....	24			
15.2	Wave and reflow soldering .....	24			
15.3	Wave soldering .....	24			
15.4	Reflow soldering .....	25			
<b>16</b>	<b>Abbreviations</b> .....	<b>26</b>			
<b>17</b>	<b>Revision history</b> .....	<b>27</b>			

Please be aware that important notices concerning this document and the product(s) described herein, have been included in section 'Legal information'.

© NXP Semiconductors N.V. 2016.

All rights reserved.

For more information, please visit: <http://www.nxp.com>

For sales office addresses, please send an email to: [salesaddresses@nxp.com](mailto:salesaddresses@nxp.com)

Date of release: 22 August 2016

Document identifier: PCA9532

Компания «Life Electronics» занимается поставками электронных компонентов импортного и отечественного производства от производителей и со складов крупных дистрибьюторов Европы, Америки и Азии.

С конца 2013 года компания активно расширяет линейку поставок компонентов по направлению коаксиальный кабель, кварцевые генераторы и конденсаторы (керамические, пленочные, электролитические), за счёт заключения дистрибьюторских договоров

Мы предлагаем:

- Конкуренспособные цены и скидки постоянным клиентам.
- Специальные условия для постоянных клиентов.
- Подбор аналогов.
- Поставку компонентов в любых объемах, удовлетворяющих вашим потребностям.
- Приемлемые сроки поставки, возможна ускоренная поставка.
- Доставку товара в любую точку России и стран СНГ.
- Комплексную поставку.
- Работу по проектам и поставку образцов.
- Формирование склада под заказчика.
- Сертификаты соответствия на поставляемую продукцию (по желанию клиента).
- Тестирование поставляемой продукции.
- Поставку компонентов, требующих военную и космическую приемку.
- Входной контроль качества.
- Наличие сертификата ISO.

В составе нашей компании организован Конструкторский отдел, призванный помогать разработчикам, и инженерам.

Конструкторский отдел помогает осуществить:

- Регистрацию проекта у производителя компонентов.
- Техническую поддержку проекта.
- Защиту от снятия компонента с производства.
- Оценку стоимости проекта по компонентам.
- Изготовление тестовой платы монтаж и пусконаладочные работы.



Тел: +7 (812) 336 43 04 (многоканальный)

Email: [org@lifeelectronics.ru](mailto:org@lifeelectronics.ru)