

Automotive-grade N-channel 60 V, 35 mΩ typ., 6.5 A STripFET™ F3 Power MOSFET in a PowerFLAT™ 5x6 package

Datasheet - production data

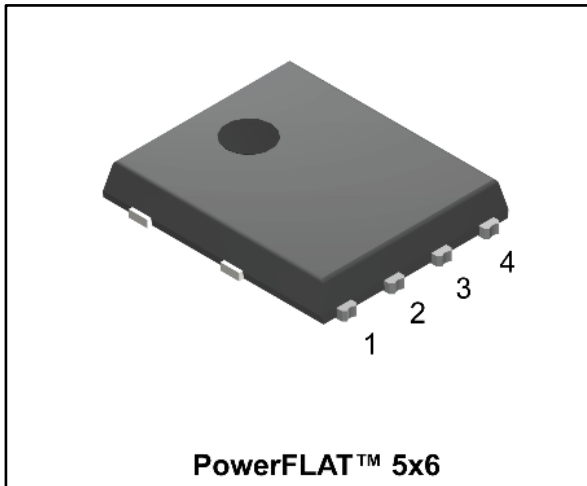
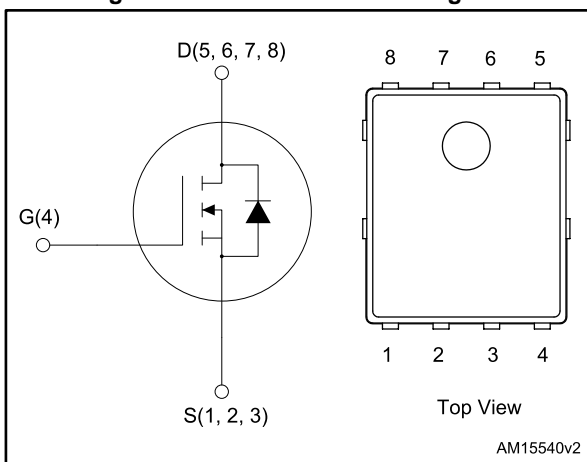

Figure 1: Internal schematic diagram



Features

Order code	V _{DS}	R _{DS(on)} max.	I _D
STL7N6LF3	60 V	43 mΩ	6.5 A

- AEC-Q101 qualified
- Logic level V_{GS(th)}
- 175 °C maximum junction temperature
- 100% avalanche rated
- Wettable flank package



Applications

- Switching applications

Description

This device is an N-channel Power MOSFET developed using STripFET™ F3 technology. It is designed to minimize on-resistance and gate charge to provide superior switching performance.

Table 1: Device summary

Order code	Marking	Package	Packing
STL7N6LF3	7N6LF3	PowerFLAT™ 5x6	Tape and reel

Contents

1	Electrical ratings	3
2	Electrical characteristics	4
	2.1 Electrical characteristics (curves).....	6
3	Test circuits	8
4	Package information	9
	4.1 PowerFLAT 5x6 WF type R package information	9
	4.2 Packing information.....	12
5	Revision history	14

1 Electrical ratings

Table 2: Absolute maximum ratings

Symbol	Parameter	Value	Unit
V_{DS}	Drain-source voltage	60	V
V_{GS}	Gate-source voltage	± 20	V
$I_D^{(1)}$	Drain current (continuous) at $T_C = 25\text{ }^\circ\text{C}$	20	A
$I_D^{(1)}$	Drain current (continuous) at $T_C = 100\text{ }^\circ\text{C}$	16	A
$I_D^{(2)}$	Drain current (continuous) at $T_{pcb} = 25\text{ }^\circ\text{C}$	6.5	A
$I_D^{(2)}$	Drain current (continuous) at $T_{pcb} = 100\text{ }^\circ\text{C}$	4.6	A
$I_{DM}^{(3),(2)}$	Drain current (pulsed)	26	A
$P_{TOT}^{(1)}$	Total dissipation at $T_C = 25\text{ }^\circ\text{C}$	52	W
$P_{TOT}^{(2)}$	Total dissipation at $T_{pcb} = 25\text{ }^\circ\text{C}$	4.3	W
I_{AV}	Not-repetitive avalanche current	6.5	A
$E_{AS}^{(4)}$	Single pulse avalanche energy	190	mJ
T_j	Operating junction temperature range	-55 to 175	$^\circ\text{C}$
T_{stg}	Storage temperature range		

Notes:

- (1) This value is rated according to $R_{thj-case}$
- (2) This value is rated according to $R_{thj-pcb}$
- (3) Pulse width limited by safe operating area.
- (4) Starting $T_J = 25\text{ }^\circ\text{C}$, $I_D = 8\text{ A}$, $V_{DD} = 25\text{ V}$.

Table 3: Thermal resistance

Symbol	Parameter	Value	Unit
$R_{thj-case}$	Thermal resistance junction-case	2.9	$^\circ\text{C/W}$
$R_{thj-pcb}^{(1)}$	Thermal resistance junction-pcb	35	$^\circ\text{C/W}$

Notes:

- (1) When mounted on FR-4 board of 1 inch², 2oz Cu, $t < 10\text{ s}$

2 Electrical characteristics

(T_C = 25 °C unless otherwise specified)

Table 4: On/Off states

Symbol	Parameter	Test conditions	Min.	Typ.	Max.	Unit
V _{(BR)DSS}	Drain-source breakdown voltage	V _{GS} = 0 V, I _D = 250 μA	60			V
I _{DSS}	Zero gate voltage drain current	V _{GS} = 0 V, V _{DS} = 60 V			1	μA
I _{GSS}	Gate-body leakage current	V _{DS} = 0 V, V _{GS} = ±20 V			±100	nA
V _{GS(th)}	Gate threshold voltage	V _{DS} = V _{GS} , I _D = 250 μA	1		2.5	V
R _{DS(on)}	Static drain-source on-resistance	V _{GS} = 10 V, I _D = 3 A		35	43	mΩ
		V _{GS} = 5 V, I _D = 3 A		48	60	mΩ

Table 5: Dynamic

Symbol	Parameter	Test conditions	Min.	Typ.	Max.	Unit
C _{iss}	Input capacitance	V _{DS} = 25 V, f = 1 MHz, V _{GS} = 0 V	-	432	-	pF
C _{oss}	Output capacitance		-	93	-	
C _{rss}	Reverse transfer capacitance		-	10.5	-	
Q _g	Total gate charge	V _{DD} = 30 V, I _D = 6.5 A, V _{GS} = 0 to 10 V (see Figure 13: "Test circuit for gate charge behavior")	-	8.7	-	nC
Q _{gs}	Gate-source charge		-	1.9	-	
Q _{gd}	Gate-drain charge		-	1.9	-	
R _G	Intrinsic gate resistance	f = 1 MHz, I _D = 0 A	-	6.3	-	Ω

Table 6: Switching times

Symbol	Parameter	Test conditions	Min.	Typ.	Max.	Unit
t _{d(on)}	Turn-on delay time	V _{DD} = 30 V, I _D = 3 A, R _G = 4.7 Ω, V _{GS} = 10 V (see Figure 12: "Test circuit for resistive load switching times" and Figure 17: "Switching time waveform")	-	6.7	-	ns
t _r	Rise time		-	10.4	-	
t _{d(off)}	Turn-off delay time		-	32.4	-	
t _f	Fall time		-	5.4	-	

Table 7: Source-drain diode

Symbol	Parameter	Test conditions	Min.	Typ.	Max.	Unit
I_{SD}	Source-drain current		-		6.5	A
$I_{SDM}^{(1)}$	Source-drain current (pulsed)		-		26	A
$V_{SD}^{(2)}$	Forward on voltage	$I_{DS} = 6.5 \text{ A}$, $V_{GS} = 0 \text{ V}$	-		1.3	V
t_{rr}	Reverse recovery time	$I_{SD} = 6.5 \text{ A}$, $di/dt = 100 \text{ A}/\mu\text{s}$	-	24		ns
Q_{rr}	Reverse recovery charge	$V_{DD} = 48 \text{ V}$, $T_j = 150 \text{ }^\circ\text{C}$ (see Figure 14: "Test circuit for inductive load switching and diode recovery times")	-	23.3		nC
I_{RRM}	Reverse recovery current		-	1.9		A

Notes:

(1)Pulse width limited by safe operating area

(2)Pulsed: pulse duration = 300 μs , duty cycle 1.5 %

2.1 Electrical characteristics (curves)

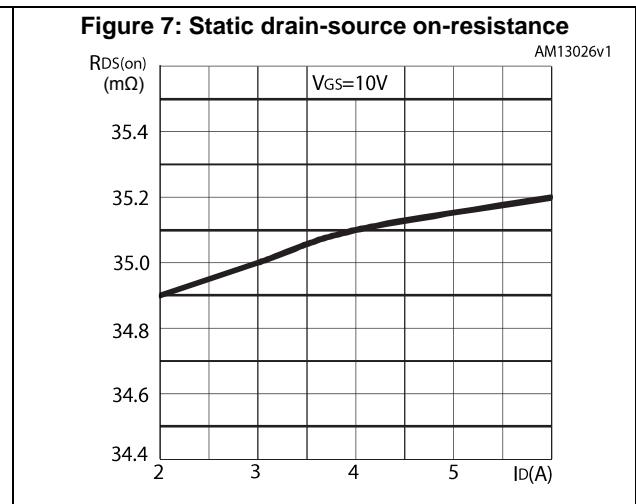
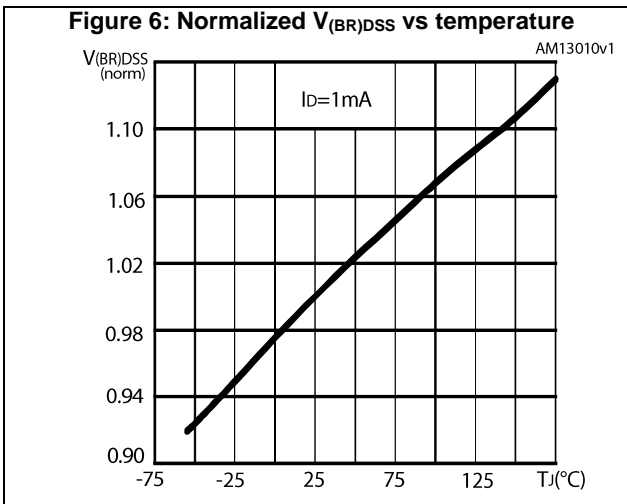
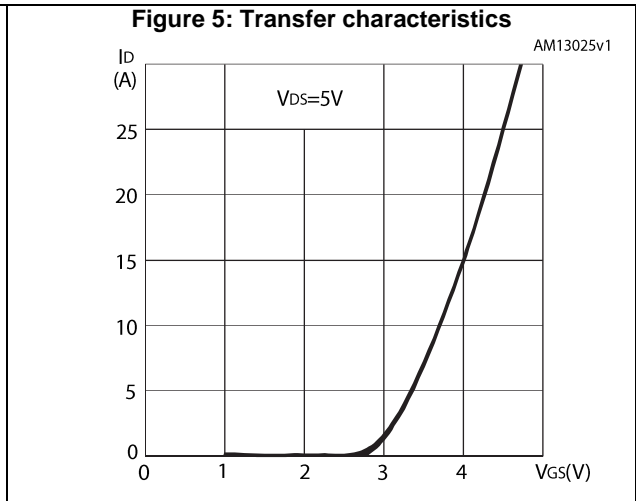
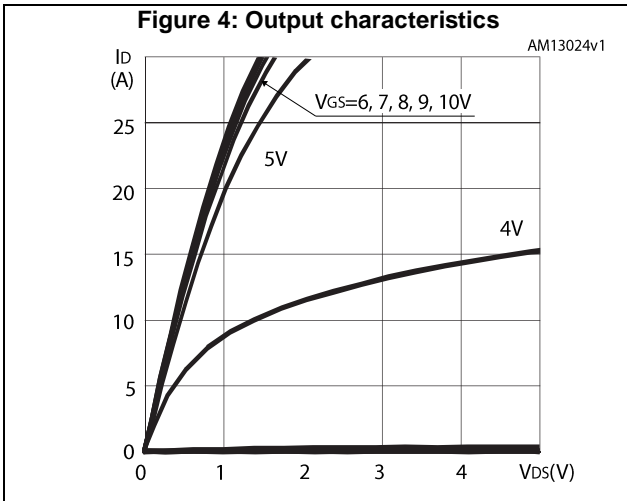
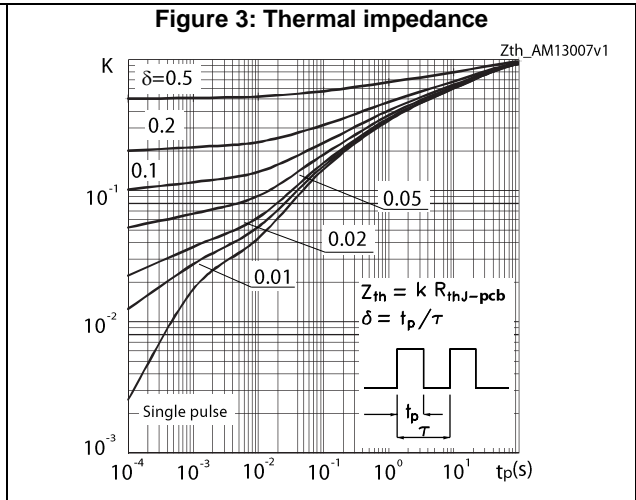
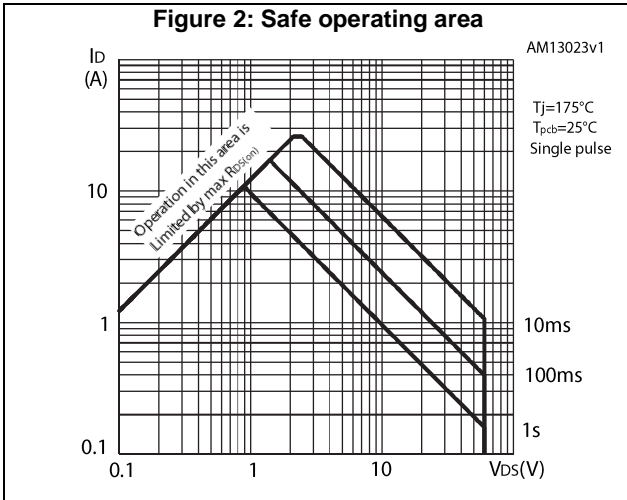

Figure 8: Gate charge vs gate-source voltage

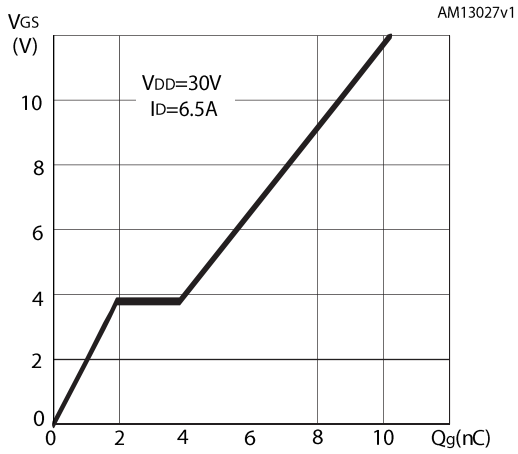

Figure 9: Capacitance variation

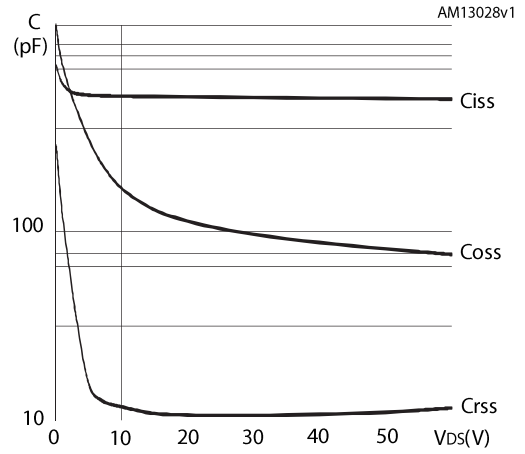

Figure 10: Normalized gate threshold voltage vs temperature

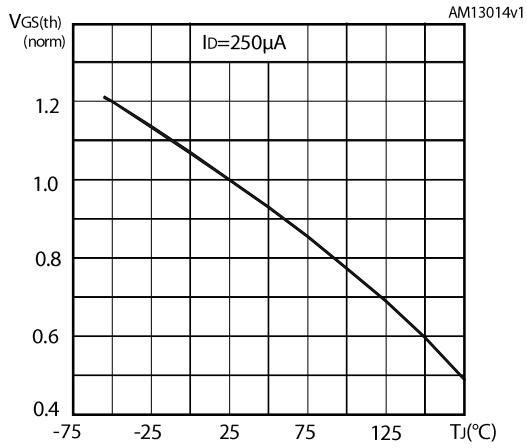
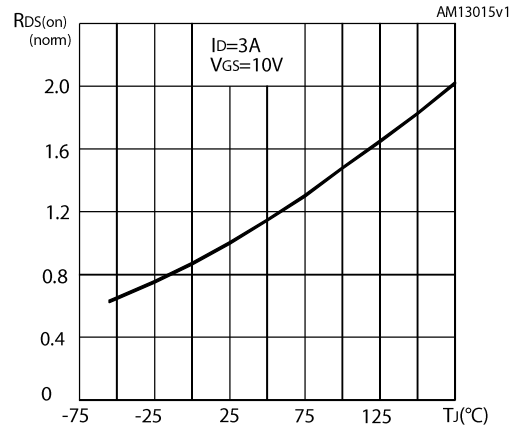
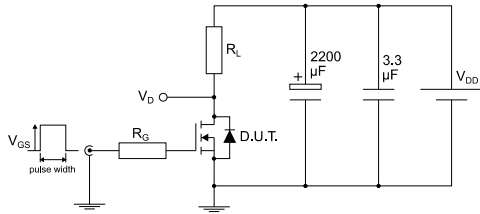

Figure 11: Normalized on-resistance vs temperature



3 Test circuits

Figure 12: Test circuit for resistive load switching times



AM01468v1

Figure 13: Test circuit for gate charge behavior

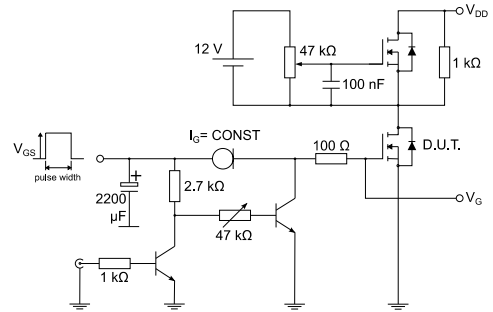

AM01469v1

Figure 14: Test circuit for inductive load switching and diode recovery times

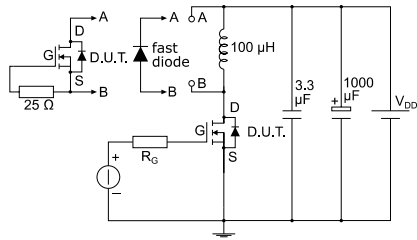

AM01470v1

Figure 15: Unclamped inductive load test circuit

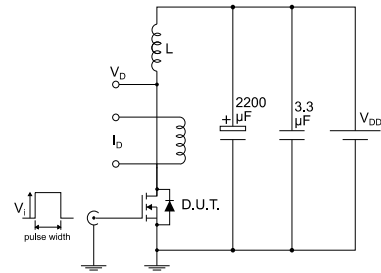

AM01471v1

Figure 16: Unclamped inductive waveform

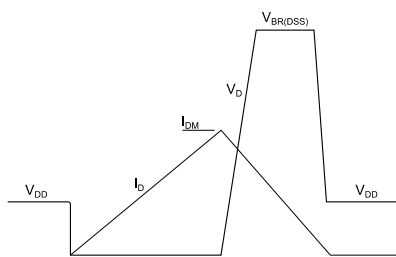

AM01472v1

Figure 17: Switching time waveform

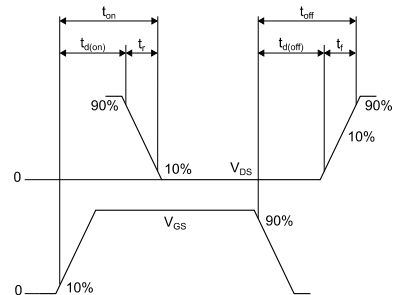

AM01473v1

4 Package information

In order to meet environmental requirements, ST offers these devices in different grades of ECOPACK® packages, depending on their level of environmental compliance. ECOPACK® specifications, grade definitions and product status are available at: www.st.com. ECOPACK® is an ST trademark.

4.1 PowerFLAT 5x6 WF type R package information

Figure 18: PowerFLAT™ 5x6 WF type R package outline

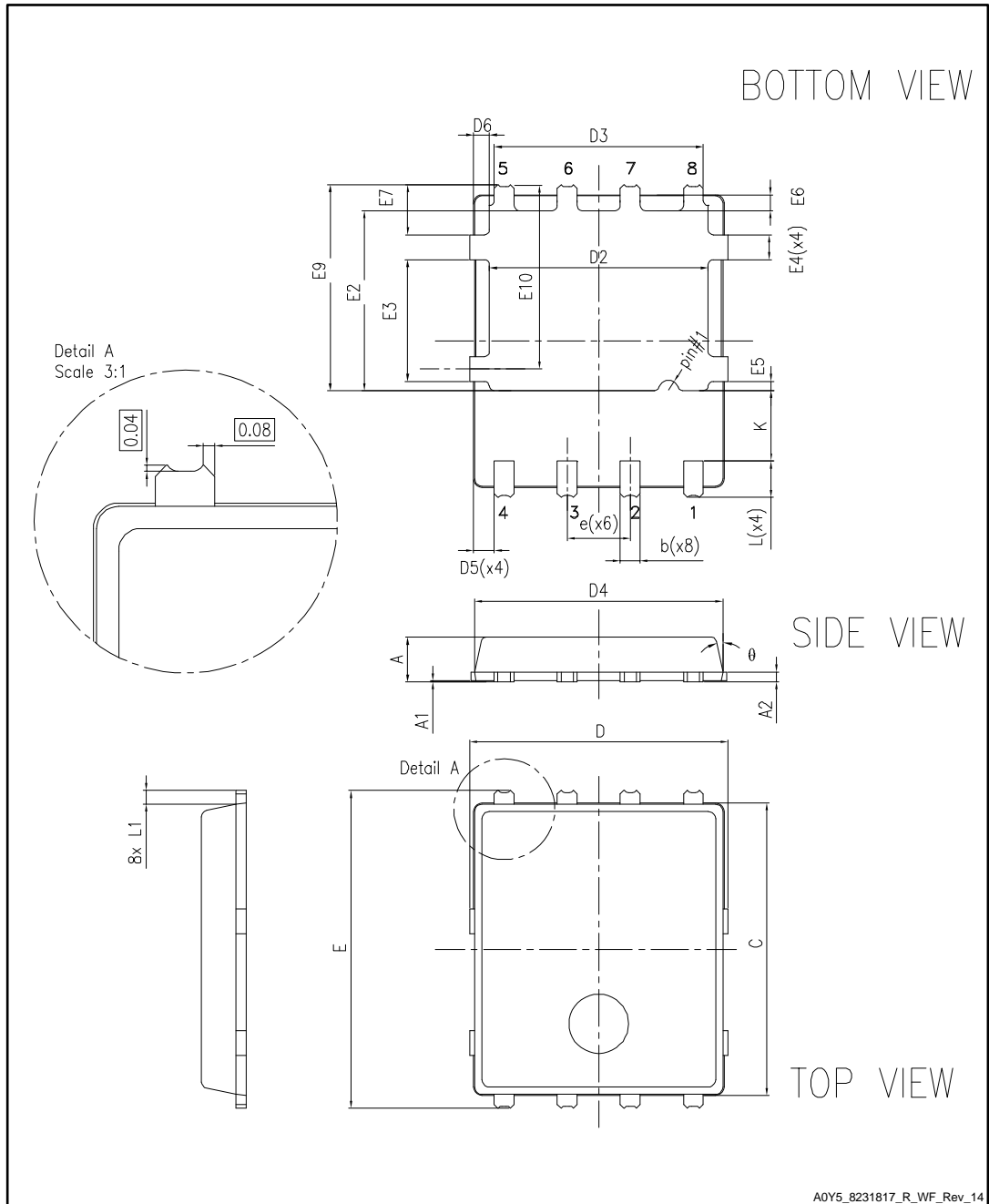

A0Y5_8231817_R_WF_Rev_14

Table 8: PowerFLAT™ 5x6 WF type R mechanical data

Dim.	mm		
	Min.	Typ.	Max.
A	0.80		1.00
A1	0.02		0.05
A2		0.25	
b	0.30		0.50
C	5.80	6.00	6.10
D	5.00	5.20	5.40
D2	4.15		4.45
D3	4.05	4.20	4.35
D4	4.80	5.00	5.10
D5	0.25	0.4	0.55
D6	0.15	0.3	0.45
e		1.27	
E	6.20	6.40	6.60
E2	3.50		3.70
E3	2.35		2.55
E4	0.40		0.60
E5	0.08		0.28
E6	0.20	0.325	0.45
E7	0.85	1.00	1.15
E9	4.00	4.20	4.40
E10	3.55	3.70	3.85
K	1.275		1.575
L	0.725	0.825	0.925
L1	0.175	0.275	0.375
θ	0°		12°

Figure 19: PowerFLAT™ 5x6 recommended footprint (dimensions are in mm)

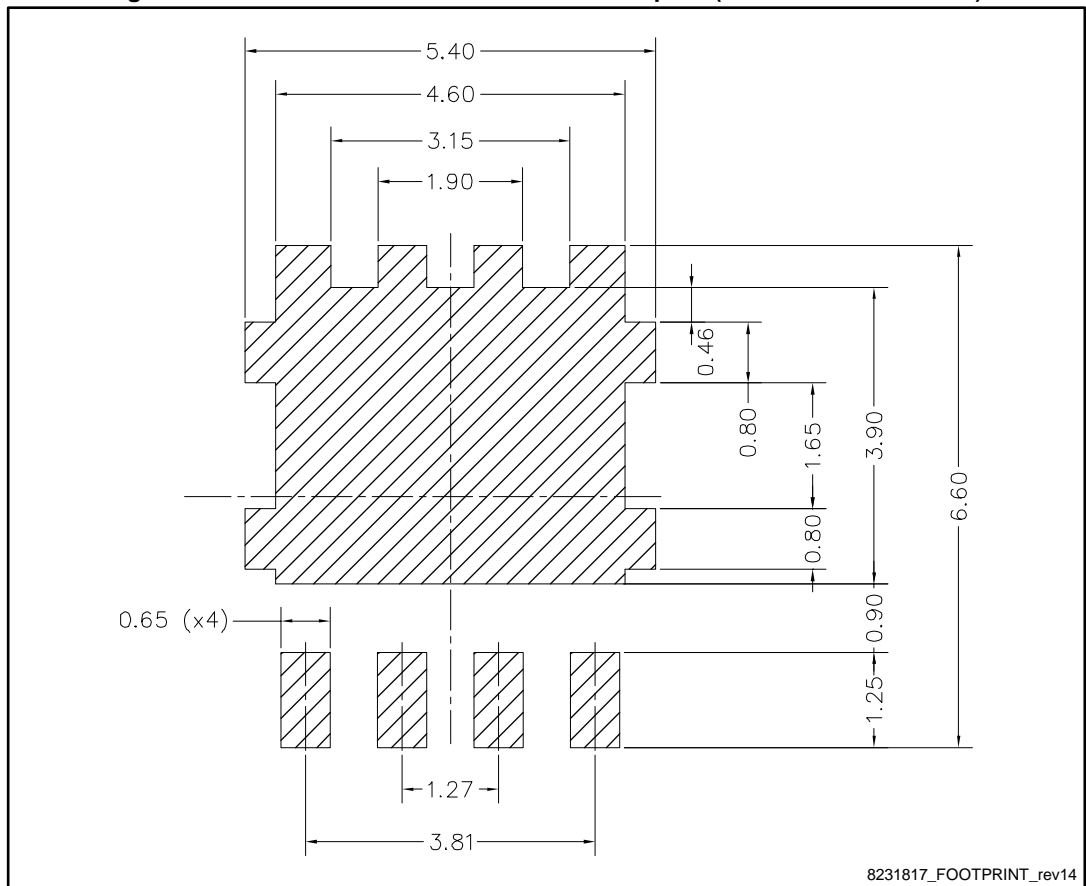

4.2 Packing information

Figure 20: PowerFLAT™ 5x6 WF tape (dimensions are in mm)

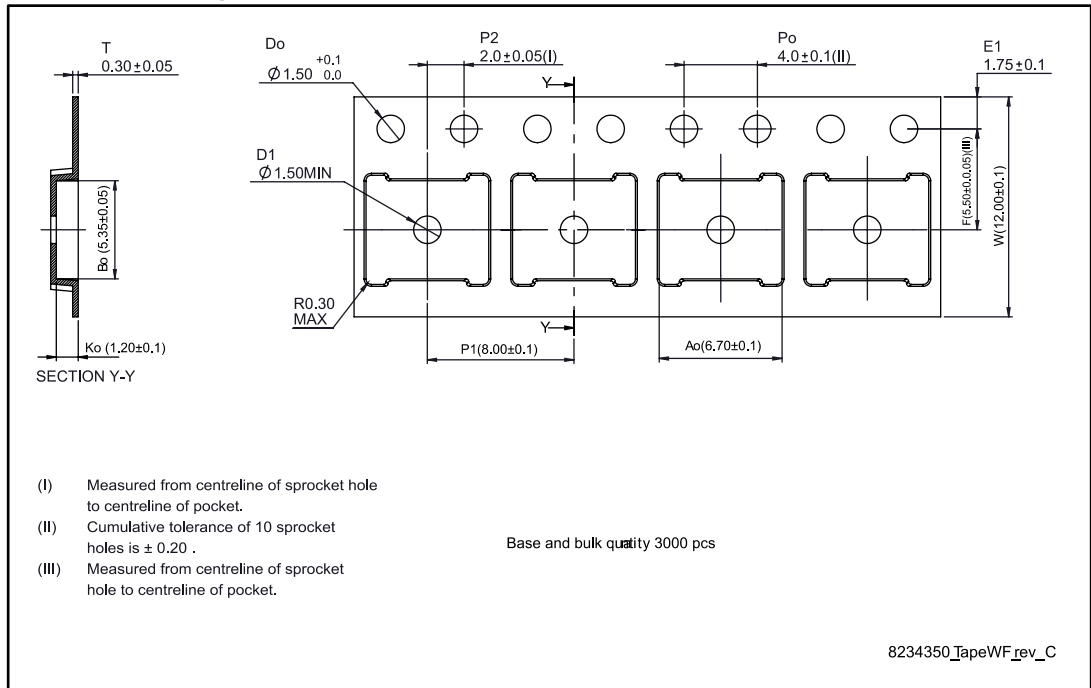

Figure 21: PowerFLAT™ 5x6 package orientation in carrier tape

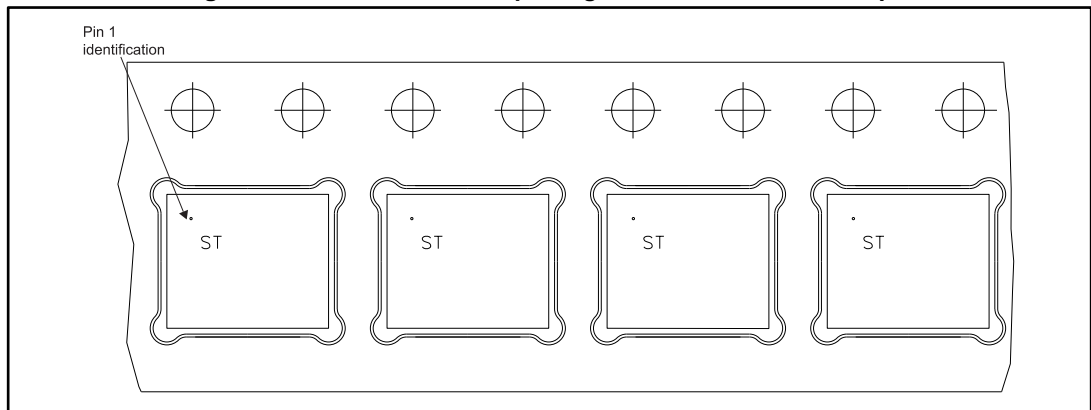
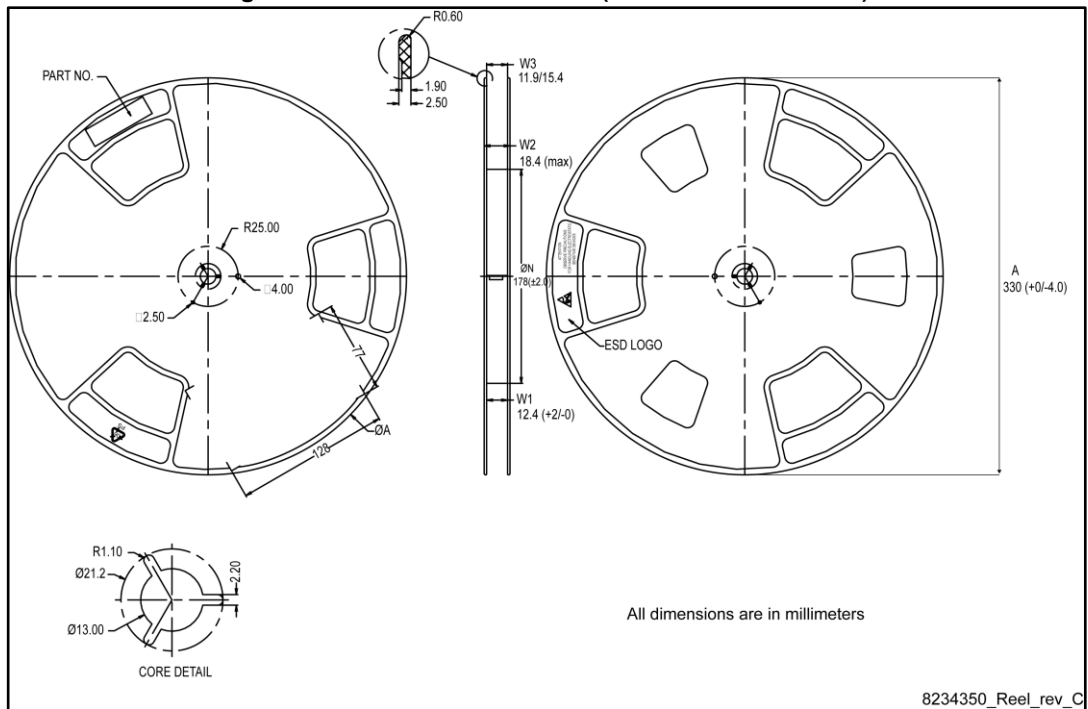

Figure 22: PowerFLAT™ 5x6 reel (dimensions are in mm)



5 Revision history

Table 9: Document revision history

Date	Revision	Changes
14-Oct-2014	1	First release.
10-Feb-2015	2	Updated <i>Table 4: On/off states</i> , <i>Table 5: Dynamic</i> , <i>Table 6: Switching times</i> , <i>Table 7: Source drain diode</i> and <i>Section 4: Package mechanical data</i> .
26-May-2015	3	Updated title and features. Document status from preliminary to production data.
13-Feb-2017	4	Modified features on cover page. Modified <i>Table 2: "Absolute maximum ratings"</i> and <i>Table 5: "Dynamic"</i> . Minor text changes.

IMPORTANT NOTICE – PLEASE READ CAREFULLY

STMicroelectronics NV and its subsidiaries ("ST") reserve the right to make changes, corrections, enhancements, modifications, and improvements to ST products and/or to this document at any time without notice. Purchasers should obtain the latest relevant information on ST products before placing orders. ST products are sold pursuant to ST's terms and conditions of sale in place at the time of order acknowledgement.

Purchasers are solely responsible for the choice, selection, and use of ST products and ST assumes no liability for application assistance or the design of Purchasers' products.

No license, express or implied, to any intellectual property right is granted by ST herein.

Resale of ST products with provisions different from the information set forth herein shall void any warranty granted by ST for such product.

ST and the ST logo are trademarks of ST. All other product or service names are the property of their respective owners.

Information in this document supersedes and replaces information previously supplied in any prior versions of this document.

© 2017 STMicroelectronics – All rights reserved

Компания «Life Electronics» занимается поставками электронных компонентов импортного и отечественного производства от производителей и со складов крупных дистрибьюторов Европы, Америки и Азии.

С конца 2013 года компания активно расширяет линейку поставок компонентов по направлению коаксиальный кабель, кварцевые генераторы и конденсаторы (керамические, пленочные, электролитические), за счёт заключения дистрибьюторских договоров

Мы предлагаем:

- Конкуренспособные цены и скидки постоянным клиентам.
- Специальные условия для постоянных клиентов.
- Подбор аналогов.
- Поставку компонентов в любых объемах, удовлетворяющих вашим потребностям.
- Приемлемые сроки поставки, возможна ускоренная поставка.
- Доставку товара в любую точку России и стран СНГ.
- Комплексную поставку.
- Работу по проектам и поставку образцов.
- Формирование склада под заказчика.
- Сертификаты соответствия на поставляемую продукцию (по желанию клиента).
- Тестирование поставляемой продукции.
- Поставку компонентов, требующих военную и космическую приемку.
- Входной контроль качества.
- Наличие сертификата ISO.

В составе нашей компании организован Конструкторский отдел, призванный помогать разработчикам, и инженерам.

Конструкторский отдел помогает осуществить:

- Регистрацию проекта у производителя компонентов.
- Техническую поддержку проекта.
- Защиту от снятия компонента с производства.
- Оценку стоимости проекта по компонентам.
- Изготовление тестовой платы монтаж и пусконаладочные работы.



Тел: +7 (812) 336 43 04 (многоканальный)
Email: org@lifeelectronics.ru