

## MAX96705

## 16-Bit GMSL Serializer with High-Immunity/ Bandwidth Mode and Coax/STP Cable Drive

### General Description

The MAX96705 is a compact serializer with features especially suited for automotive camera applications. It is function and pin compatible with the MAX9271. In high-bandwidth mode, the parallel-clock maximum is 116MHz for 12-bit linear or combined HDR data types.

The embedded control channel operates at 9.6kbps to 1Mbps in UART, I<sup>2</sup>C, and mixed UART/I<sup>2</sup>C modes, allowing programming of serializer, deserializer, and camera registers independent of video timing.

For driving longer cables, the IC has programmable pre/deemphasis. Programmable spread spectrum is available on the serial output. The serial output meets ISO 10605 and IEC 61000-4-2 ESD standards. The core supply range is 1.7V to 1.9V, and the I/O supply range is 1.7V to 3.6V.

The MAX96705 is available in a 32-pin (5mm x 5mm) TQFN package with 0.5mm lead pitch, and operates over the -40°C to +115°C temperature range.

### Applications

- Automotive Camera Applications

### Simplified Block Diagram

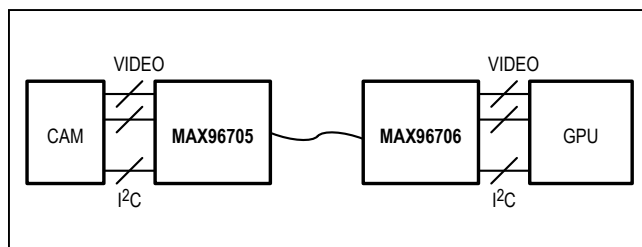

**Ordering Information** appears at end of data sheet.

### Benefits and Features

- Ideal for Safety Camera Applications
  - Works with Low-Cost 50Ω Coax (100Ω STP) Cables
  - Error Detection of Video/Control Data
  - High-Immunity Mode for Robust Control-Channel EMC Tolerance
  - Retransmission of Control Data Upon Error Detection
  - Best-in-Class Supply Current: 93mA (max)
  - Pre/Deemphasis Allows 15m Cable at Full Speed
  - 32-Pin (5mm x 5mm) TQFN Package with 0.5mm Lead Pitch
- High-Speed Data Serialization for Megapixel Cameras
  - Up to 1.74Gbps Serial-Bit Rate
  - 12.5MHz to 87MHz x 14 Bit + H/V Data
  - 36.66MHz to 116MHz x 12-Bit + H/V Data (through Internal Encoding)
- Multiple Modes for System Flexibility
  - 9.6kbps to 1Mbps Control Channel in UART, I<sup>2</sup>C (with Clock Stretch), or UART-to-I<sup>2</sup>C Modes
  - Crosspoint Switch Accepts Any Input Bitmap
  - Modes for Encoded VSYNC and HSYNC
- Reduces EMI and Shielding Requirements
  - Programmable Output Spread Spectrum
  - Tracks Spread Spectrum Applied at the Parallel Input
  - 1.7V to 3.6V I/O Supply
- Peripheral Features for Camera Power-Up and Verification
  - Built-In PRBS Generator for BER Testing
  - Dedicated GPO for Camera Frame-Sync Trigger and Other Uses
  - Remote/Local Wake-Up from Sleep Mode
- Meets AEC-Q100 Automotive Specification
  - -40°C to +115°C Operating Temperature
  - ±8kV Contact and ±15kV Air IEC 61000-4-2 and ISO 10605 ESD Protection

---

**TABLE OF CONTENTS**

---

General Description . . . . .	1
Applications . . . . .	1
Benefits and Features . . . . .	1
Simplified Block Diagram . . . . .	1
Absolute Maximum Ratings . . . . .	6
Package Information . . . . .	6
32-Pin TQFN-EP . . . . .	6
DC Electrical Characteristics . . . . .	7
AC Electrical Characteristics . . . . .	10
Typical Operating Characteristics . . . . .	13
Pin Configuration . . . . .	15
Pin Description . . . . .	15
Functional Block Diagram . . . . .	18
Detailed Description . . . . .	23
Serial Link Signaling and Data Format . . . . .	23
Operating Modes . . . . .	23
Video/Configuration Link . . . . .	23
Single/Double Mode . . . . .	24
HS/VS Encoding . . . . .	24
Error Detection . . . . .	24
Bus Widths . . . . .	24
Control Channel and Register Programming . . . . .	28
Forward Control Channel . . . . .	28
Reverse Control Channel . . . . .	28
UART Interface . . . . .	28
I <sup>2</sup> C Interface . . . . .	28
Remote-End Operation . . . . .	28
Clock-Stretch Timing . . . . .	28
Packet-Based I <sup>2</sup> C . . . . .	28
Packet Protocol Summary . . . . .	29
Control-Channel Error Detection and Packet Retransmission . . . . .	29
GPO/GPI Control . . . . .	29
Spread Spectrum . . . . .	29
Cable Type Configuration . . . . .	29
Crossbar Switch . . . . .	29
Video Timing Generator . . . . .	29
Shutdown/Sleep Modes . . . . .	31

**TABLE OF CONTENTS (CONTINUED)**

Configuration Link . . . . .	31
Serialization Disable . . . . .	31
Sleep Mode . . . . .	31
Power-Down Mode. . . . .	32
Link Startup Procedure . . . . .	32
Register Map . . . . .	33
GMSL Register Map . . . . .	33
Applications Information. . . . .	69
Parallel Interface . . . . .	69
Bus Data Width . . . . .	69
Bus Data Rates . . . . .	69
Crossbar-Switch Programming . . . . .	70
Recommended Crossbar-Switch Program Procedure . . . . .	70
Timing-Generator Programming . . . . .	73
Double-Mode Alignment . . . . .	73
External High/Low Signal . . . . .	73
Align from HS or DE . . . . .	73
Control-Channel Interfaces. . . . .	73
I <sup>2</sup> C . . . . .	73
I <sup>2</sup> C Bit Rate . . . . .	73
Software Programming of Device Addresses . . . . .	74
I <sup>2</sup> C Address Translation. . . . .	74
Configuration Blocking . . . . .	74
Cascaded/Parallel Devices . . . . .	74
UART . . . . .	74
Base Mode . . . . .	74
UART Timing . . . . .	74
UART-to-I <sup>2</sup> C Conversion . . . . .	76
UART Bypass Mode . . . . .	77
Device Address . . . . .	77
Spread Spectrum . . . . .	77
Manual Programming of the Spread-Spectrum Divider . . . . .	77
Equation: . . . . .	77
Board Layout. . . . .	78
Power-Supply Circuits and Bypassing. . . . .	78
High-Frequency Signals. . . . .	78
ESD Protection . . . . .	78

**TABLE OF CONTENTS (CONTINUED)**

Compatibility with Other GMSL Devices .....	79
Device Configuration and Component Selection .....	79
Internal Input Pulldowns .....	79
Three-Level Configuration Inputs .....	79
I <sup>2</sup> C/UART Pullup Resistors .....	80
AC-Coupling Capacitors .....	80
Cables and Connectors .....	80
PRBS .....	80
GPI/GPO .....	80
Fast Detection of Loss-of-Lock .....	81
Providing a Frame Sync (Camera Applications) .....	81
Entering/Exiting Sleep Mode .....	81
Typical Application Circuits .....	82
Ordering Information .....	82
Revision History .....	83

**LIST OF FIGURES**

Figure 1. Serial-Output Parameters .....	18
Figure 2. Output Waveforms at OUT+, OUT- .....	19
Figure 3. Single-Ended Output Template .....	19
Figure 4. Worst-Case Pattern Input .....	19
Figure 5. Parallel Clock Input Requirements .....	19
Figure 6. I <sup>2</sup> C Timing Parameters .....	20
Figure 7. Differential Output Template .....	20
Figure 8. Input Setup and Hold Times .....	21
Figure 9. GPI-to-GPO Delay .....	21
Figure 10. Serializer Delay .....	22
Figure 11. Link Startup Time .....	22
Figure 12. Power-Up Delay .....	23
Figure 13. 24-Bit Mode Serial-Data Format .....	25
Figure 14. 27-Bit High-Bandwidth Mode Serial-Data Format .....	26
Figure 15. 32-Bit Mode Serial-Data Format .....	27
Figure 16. Coax Connection .....	29
Figure 17. Crossbar Switch Dataflow .....	30
Figure 18. Sync-Signal Format For Video-Timing Generation .....	30
Figure 19. State Diagram .....	31
Figure 20. Crossbar-Switch Default Mapping .....	72

---

**LIST OF FIGURES (CONTINUED)**

---

Figure 21. GMSL-UART Data Format for Base Mode . . . . .	75
Figure 22. GMSL-UART Protocol for Base Mode . . . . .	75
Figure 23. SYNC Byte (0x79). . . . .	75
Figure 24. ACK Byte (0xC3). . . . .	75
Figure 25. Format Conversion Between GMSL UART and I <sup>2</sup> C with Register Address (I2CMETHOD = 0). . . . .	76
Figure 26. Format Conversion Between GMSL UART and I <sup>2</sup> C with Register Address (I2CMETHOD = 1). . . . .	76
Figure 27. Human Body Model ESD Test Circuit. . . . .	78
Figure 28. IEC 61000-4-2 Contact Discharge ESD Test Circuit . . . . .	78
Figure 29. ISO 10605 Contact Discharge ESD Test Circuit . . . . .	78

---

**LIST OF TABLES**

---

Table 1. Reverse Control-Channel Modes . . . . .	28
Table 2. Link-Startup Procedure . . . . .	31
Table 3. Input Data-Width Selection . . . . .	68
Table 4. Data-Rate Selection . . . . .	68
Table 5. Crossbar Output to Serial Link Map (D23:0) . . . . .	69
Table 6. Crossbar Output to Serial Link Map (D31:24 and Special Packets) . . . . .	70
Table 7. Legend . . . . .	71
Table 8. Timing-Generator Parameter Restrictions . . . . .	72
Table 9. Output Spread . . . . .	76
Table 10. Spread Limitations . . . . .	76
Table 11. Modulation Coefficients and Maximum SDIV Settings . . . . .	77
Table 12. Feature Compatibility . . . . .	78
Table 13. Three-Level Configuration Input Map . . . . .	79
Table 14. Suggested Connectors and Cables for GMSL. . . . .	79

### Absolute Maximum Ratings

AVDD to EP* .....	-0.5V to +1.9V	Continuous Power Dissipation, T <sub>A</sub> = +70°C
DVDD to EP* .....	-0.5V to +1.9V	TQFN (derate 34.5 mW/°C above +70°C) .....
IOVDD to EP* .....	-0.5V to +3.9V	Operating Temperature Range .....
OUT+, OUT- to EP* .....	-0.5V to +1.9V	Junction Temperature .....
All Other Pins to EP* .....	-0.5V to (IOVDD + 0.5V)	Storage Temperature Range .....
OUT+, OUT- Short Circuit to Ground or Supply .....	Continuous	Soldering Temperature (reflow) .....

\*EP connected to IC ground.

Stresses beyond those listed under "Absolute Maximum Ratings" may cause permanent damage to the device. These are stress ratings only, and functional operation of the device at these or any other conditions beyond those indicated in the operational sections of the specifications is not implied. Exposure to absolute maximum rating conditions for extended periods may affect device reliability.

### Package Information

For the latest package outline information and land patterns (footprints), go to [www.maximintegrated.com/packages](http://www.maximintegrated.com/packages). Note that a "+", "#", or "-" in the package code indicates RoHS status only. Package drawings may show a different suffix character, but the drawing pertains to the package regardless of RoHS status.

#### 32-Pin TQFN-EP

Package Code	T3255+8
Outline Number	<a href="#">21-0140</a>
Land Pattern Number	<a href="#">90-0013</a>
<b>Single-Layer Board:</b>	
Junction-to-Ambient Thermal Resistance (θ <sub>JA</sub> )	47
Junction-to-Case Thermal Resistance (θ <sub>JC</sub> )	1.7
<b>Four-Layer Board:</b>	
Junction-to-Ambient Thermal Resistance (θ <sub>JA</sub> )	29
Junction-to-Case Thermal Resistance (θ <sub>JC</sub> )	1.7

Package thermal resistances were obtained using the method described in JEDEC specification JESD51-7, using a four-layer board. For detailed information on package thermal considerations, refer to [www.maximintegrated.com/thermal-tutorial](http://www.maximintegrated.com/thermal-tutorial).

**DC Electrical Characteristics**

( $V_{DVDD} = V_{AVDD} = 1.7V$  to  $1.9V$ ,  $V_{IOVDD} = 1.7V$  to  $3.6V$ ,  $R_L = 100\Omega \pm 1\%$  (differential),  $T_A = -40^\circ C$  to  $+115^\circ C$ , EP connected to PCB ground, typical values are at  $V_{DVDD} = V_{AVDD} = V_{IOVDD} = 1.8V$ ,  $T_A = +25^\circ C$ , unless otherwise noted.) (Note 1)

PARAMETER	SYMBOL	CONDITIONS	MIN	TYP	MAX	UNITS
<b>SINGLE-ENDED INPUTS (LCCEN, DIN_, PCLKIN, HS, VS, DE, BWS, DBL, HIM, MS, HVEN, PWDNB)</b>						
High-Level Input Voltage	$V_{IH}$		0.65 x $V_{IOVDD}$			V
Low-Level Input Voltage	$V_{IL}$			0.35 x $V_{IOVDD}$		V
Input Current	$I_{IN}$	$V_{IN} = 0$ to $V_{IOVDD}$	-20		+20	$\mu A$
<b>THREE-LEVEL INPUTS (CONF0, CONF1)</b>						
High-Level Input Voltage	$V_{IH}$		0.7 x $V_{IOVDD}$			V
Low-Level Input Voltage	$V_{IL}$			0.3 x $V_{IOVDD}$		V
Mid-Level Input Current	$I_{INM}$	Open or connected to a driver with output in high impedance (Note 2)	-10		+10	$\mu A$
Input Current	$I_{IN}$	High or low, PWDNB high or low	-220		+220	$\mu A$
<b>SINGLE-ENDED OUTPUT (GPO)</b>						
High-Level Output Voltage	$V_{OH}$	$I_{OH} = -2mA$	$V_{IOVDD} - 0.2$			V
Low-Level Output Voltage	$V_{OL}$	$I_{OL} = 2mA$		0.2		V
Output Short-Circuit Current	$I_{OS}$	$V_O = 0V$ , $V_{IOVDD} = 3.0V$ to $3.6V$	-16	-35	-64	mA
		$V_O = 0V$ , $V_{IOVDD} = 1.7V$ to $1.9V$	-3	-12	-21	
<b>UART/I<sup>2</sup>C and GENERAL-PURPOSE I/Os (RX/SDA, TX/SCL, GPIO_) with OPEN-DRAIN OUTPUTS</b>						
High-Level Input Voltage	$V_{IH}$		0.7 x $V_{IOVDD}$			V
Low-Level Input Voltage	$V_{IL}$			0.3 x $V_{IOVDD}$		V
Input Current	$I_{IN}$	$V_{IN} = 0$ to $V_{IOVDD}$ (Note 3), RX/SDA, TX/SCL	-110		+5	$\mu A$
		$V_{IN} = 0$ to $V_{IOVDD}$ (Note 3), GPIO_	-80		+5	
Low-Level Open-Drain Output Voltage	$V_{OL}$	$I_{OL} = 3mA$ , $V_{IOVDD} = 1.7V$ to $1.9V$			0.4	V
		$I_{OL} = 3mA$ , $V_{IOVDD} = 3.0V$ to $3.6V$			0.3	
Input Capacitance	$C_{IN}$	Each pin (Note 4)			10	pF

## DC Electrical Characteristics (continued)

( $V_{DVDD} = V_{AVDD} = 1.7V$  to  $1.9V$ ,  $V_{IOVDD} = 1.7V$  to  $3.6V$ ,  $R_L = 100\Omega \pm 1\%$  (differential),  $T_A = -40^\circ C$  to  $+115^\circ C$ , EP connected to PCB ground, typical values are at,  $V_{DVDD} = V_{AVDD} = V_{IOVDD} = 1.8V$ ,  $T_A = +25^\circ C$ , unless otherwise noted.) (Note 1)

PARAMETER	SYMBOL	CONDITIONS	MIN	TYP	MAX	UNITS
<b>DIFFERENTIAL OUTPUTS (OUT+, OUT-)</b>						
Differential Output Voltage	$V_{OD}$	Preemphasis off, high drive (Figure 1)	300	400	500	mV
		3.3dB preemphasis, high drive (Figure 2)	350		610	
		3.3dB deemphasis, high drive (Figure 2)	240		425	
Change in $V_{OD}$ Between Complementary Output States	$\Delta V_{OD}$				25	mV
Output Offset Voltage ( $V_{OUT+} + V_{OUT-})/2 = V_{OS}$	$V_{OS}$	Preemphasis off	1.1	1.4	1.56	V
Change in $V_{OS}$ Between Complementary Output States	$\Delta V_{OS}$				25	mV
Output Short-Circuit Current	$I_{OS}$	$V_{OUT+}$ or $V_{OUT-} = 0V$	-60			mA
		$V_{OUT+}$ or $V_{OUT-} = 1.9V$			25	
Magnitude of Differential Output Short-Circuit Current	$I_{OSD}$	$V_{OD} = 0V$			25	mA
Output-Termination Resistance (Internal)	$R_O$	From OUT+ or OUT- to AVDD	45	54	63	$\Omega$
<b>REVERSE CONTROL-CHANNEL RECEIVER OUTPUTS (OUT+, OUT-)</b>						
High-Switching Threshold	$V_{CHR}$	Legacy			27	mV
		High immunity			40	
Low-Switching Threshold	$V_{CLR}$	Legacy	-27			mV
		High immunity	-40			
<b>SINGLE-ENDED SERIAL OUTPUTS (OUT+ or OUT-)</b>						
Single-Ended Output Voltage	$V_O$	Preemphasis off, high drive (Figure 3)	375	500	625	mV
		3.3dB preemphasis, high drive (Figure 2)	435		765	
		3.3dB deemphasis, high drive (Figure 2)	300		535	
Output Short-Circuit Current	$I_{OS}$	$V_{OUT+}$ or $V_{OUT-} = 0V$	-69			mA
		$V_{OUT+}$ or $V_{OUT-} = 1.9V$			32	
Output-Termination Resistance (Internal)	$R_O$	From OUT+ or OUT- to AVDD	45	54	63	$\Omega$



**DC Electrical Characteristics (continued)**

( $V_{DVDD} = V_{AVDD} = 1.7V$  to  $1.9V$ ,  $V_{IOVDD} = 1.7V$  to  $3.6V$ ,  $R_L = 100\Omega \pm 1\%$  (differential),  $T_A = -40^\circ C$  to  $+115^\circ C$ , EP Connected to PCB ground, typical values are at,  $V_{DVDD} = V_{AVDD} = V_{IOVDD} = 1.8V$ ,  $T_A = +25^\circ C$ , unless otherwise noted.) (Note 1)

PARAMETER	SYMBOL	CONDITIONS	MIN	TYP	MAX	UNITS
<b>POWER SUPPLY</b>						
Supply Current, Worst-Case Pattern (Figure 4)	$I_{WCS}$	$f_{PCLKIN} = 116MHz$ , HIBW = 0, BWS = 0, default register values, AVDD + DVDD (1.9V)		64	90	mA
		$f_{PCLKIN} = 116MHz$ , HIBW = 0, BWS = 0, default register values, IOVDD (3.6V)		1.8	2.7	
		$f_{PCLKIN} = 116MHz$ , HIBW = 0, BWS = 0, default register values, IOVDD (1.9V) (Note 4)		0.45	0.69	
		$f_{PCLKIN} = 116MHz$ , HIBW = 1, BWS = 0, default register values, AVDD + DVDD (1.9V)		62	83	
		$f_{PCLKIN} = 116MHz$ , HIBW = 1, BWS = 0, default register values, IOVDD (3.6V)		1.8	2.7	
		$f_{PCLKIN} = 116MHz$ , HIBW = 1, BWS = 0, default register values, IOVDD (1.9V) (Note 4)		0.45	0.69	
		$f_{PCLKIN} = 87MHz$ , BWS = 1, default register values, AVDD + DVDD (1.9V)		61	85	
		$f_{PCLKIN} = 87MHz$ , BWS = 1, default register values, IOVDD (3.6V)		1.4	2.0	
		$f_{PCLKIN} = 87MHz$ , BWS = 1, default register values, IOVDD (1.9V) (Note 4)		0.37	0.61	
Sleep-Mode Supply Current	$I_{CCS}$	Wake-up receiver enabled		40	100	$\mu A$
Power-Down Supply Current	$I_{CCZ}$	PWDNB = low		15	70	$\mu A$
<b>ESD PROTECTION</b>						
OUT+, OUT- (Note 5)	$V_{ESD}$	Human Body Model, $R_D = 1.5k\Omega$ , $C_S = 100pF$		$\pm 8$		kV
		IEC 61000-4-2, $R_D = 330\Omega$ , $C_S = 150pF$ , Contact Discharge		$\pm 8$		
		IEC 61000-4-2, $R_D = 330\Omega$ , $C_S = 150pF$ , Air Discharge		$\pm 15$		
		ISO 10605, $R_D = 2k\Omega$ , $C_S = 330pF$ , Contact Discharge		$\pm 8$		
		ISO 10605, $R_D = 2k\Omega$ , $C_S = 330pF$ , Air Discharge		$\pm 15$		
All Other Pins (Note 6)	$V_{ESD}$	Human Body Model, $R_D = 1.5k\Omega$ , $C_S = 100pF$		$\pm 4$		kV

## AC Electrical Characteristics

( $V_{DVDD} = V_{AVDD} = 1.7V$  to  $1.9V$ ,  $V_{IOVDD} = 1.7V$  to  $3.6V$ ,  $R_L = 100\Omega \pm 1\%$  (differential),  $T_A = -40^\circ C$  to  $+115^\circ C$ , EP connected to PCB ground, typical values are at,  $V_{DVDD} = V_{AVDD} = V_{IOVDD} = 1.8V$ ,  $T_A = +25^\circ C$ , unless otherwise noted.) (Note 1)

PARAMETER	SYMBOL	CONDITIONS	MIN	TYP	MAX	UNITS
<b>PARALLEL CLOCK INPUT (PCLKIN)</b>						
Clock Frequency	$f_{PCLKIN}$	BWS = 0, HIBW = 0, single input	16.66		58	MHz
		BWS = 0, HIBW = 1, single input	36.66		58	
		BWS = 1, single input	12.5		43.5	
		BWS = 0, HIBW = 0, double input	33.32		116	
		BWS = 0, HIBW = 1, double input	73.33		116	
		BWS = 1, double input	25		87	
Clock Duty Cycle	DC	$t_{HIGH}/t_T$ or $t_{LOW}/t_T$ (Note 4, <a href="#">Figure 5</a> )	35	50	65	%
Clock Transition Time	$t_R, t_F$	(Note 4, <a href="#">Figure 5</a> )			4	ns
Clock Jitter	$t_J$	1.74Gbps bit rate, 300kHz sinusoidal jitter (Note 4)			800	ps
<b>I<sup>2</sup>C/UART PORT TIMING</b>						
I <sup>2</sup> C/UART Bit Rate			9.6		1000	kbps
Output Rise Time	$t_R$	30% to 70%, $C_L = 10pF$ to $100pF$ , $1k\Omega$ pullup to IOVDD	20		150	ns
Output Fall Time	$t_F$	70% to 30%, $C_L = 10pF$ to $100pF$ , $1k\Omega$ pullup to IOVDD	20		150	ns
<b>I<sup>2</sup>C TIMING (<a href="#">Figure 6</a>)</b>						
SCL Clock Frequency	$f_{SCL}$	Low $f_{SCL}$ range: (I2CMSTBT = 010, I2CSLVSH = 10)	9.6		100	kHz
		Mid $f_{SCL}$ range: (I2CMSTBT 101, I2CSLVSH = 01)	> 100		400	
		High $f_{SCL}$ range: (I2CMSTBT = 111, I2CSLVSH = 00)	> 400		1000	
START Condition Hold Time	$t_{HD:STA}$	$f_{SCL}$ range, low	4			$\mu s$
		$f_{SCL}$ range, mid	0.6			
		$f_{SCL}$ range, high	0.26			
Low Period of SCL Clock	$t_{LOW}$	$f_{SCL}$ range, low	4.7			$\mu s$
		$f_{SCL}$ range, mid	1.3			
		$f_{SCL}$ range, high	0.5			
High Period of SCL Clock	$t_{HIGH}$	$f_{SCL}$ range, low	4			$\mu s$
		$f_{SCL}$ range, mid	0.6			
		$f_{SCL}$ range, high	0.26			
Repeated START Condition Setup Time	$t_{SU:STA}$	$f_{SCL}$ range, low	4.7			$\mu s$
		$f_{SCL}$ range, mid	0.6			
		$f_{SCL}$ range, high	0.26			

**AC Electrical Characteristics (continued)**

( $V_{DVDD} = V_{AVDD} = 1.7V$  to  $1.9V$ ,  $V_{IOVDD} = 1.7V$  to  $3.6V$ ,  $R_L = 100\Omega \pm 1\%$  (differential),  $T_A = -40^\circ C$  to  $+115^\circ C$ , EP connected to PCB ground, typical values are at,  $V_{DVDD} = V_{AVDD} = V_{IOVDD} = 1.8V$ ,  $T_A = +25^\circ C$ , unless otherwise noted.) (Note 1)

PARAMETER	SYMBOL	CONDITIONS	MIN	TYP	MAX	UNITS
Data Hold Time	$t_{HD:DAT}$	f <sub>SCL</sub> range, low	0			ns
		f <sub>SCL</sub> range, mid	0			
		f <sub>SCL</sub> range, high	0			
Data Setup Time	$t_{SU:DAT}$	f <sub>SCL</sub> range, low	250			ns
		f <sub>SCL</sub> range, mid	100			
		f <sub>SCL</sub> range, high	50			
Setup Time for STOP Condition	$t_{SU:STO}$	f <sub>SCL</sub> range, low	4			μs
		f <sub>SCL</sub> range, mid	0.6			
		f <sub>SCL</sub> range, high	0.26			
Bus-Free Time	$t_{BUF}$	f <sub>SCL</sub> range, low	4.7			μs
		f <sub>SCL</sub> range, mid	1.3			
		f <sub>SCL</sub> range, high	0.5			
Data Valid Time	$t_{VD:DAT}$	f <sub>SCL</sub> range, low			3.45	μs
		f <sub>SCL</sub> range, mid			0.9	
		f <sub>SCL</sub> range, high			0.45	
Data Valid-Acknowledge Time	$t_{VD:ACK}$	f <sub>SCL</sub> range, low			3.45	μs
		f <sub>SCL</sub> range, mid			0.9	
		f <sub>SCL</sub> range, high			0.45	
Pulse Width of Spikes Suppressed	$t_{SP}$	f <sub>SCL</sub> range, low			50	ns
		f <sub>SCL</sub> range, mid			50	
		f <sub>SCL</sub> range, high			50	
Capacitive Load of Each Bus Line	$C_B$	Note 4			100	pF
<b>SWITCHING CHARACTERISTICS (Note 4)</b>						
Differential/Single-Ended Output Rise/Fall Time	$t_R, t_F$	20% to 80%, $V_{OD}$ , 400mV differential $R_L = 100\Omega$ , 500mV single-ended $R_L = 50\Omega$ , serial bit rate = 1.74Gbps			250	ps
Total Serial-Output Jitter (Differential Output)	$t_{TSOJ1}$	1.74Gbps PRBS, measured at $V_{OD} = 0V$ differential, preemphasis disabled (Figure 7)		0.25		UI
Deterministic Serial-Output Jitter (Differential Output)	$t_{DSOJ2}$	1.74Gbps PRBS, measured at $V_{OD} = 0V$ differential, preemphasis disabled (Figure 7)		0.15		UI
Total Serial-Output Jitter (Single-Ended Output)	$t_{TSOJ1}$	1.74Gbps PRBS, measured at $V_O/2$ , preemphasis disabled (Figure 3)		0.25		UI
Deterministic Serial-Output Jitter (Single-Ended Output)	$t_{DSOJ2}$	1.74Gbps PRBS, measured at $V_O/2$ , preemphasis disabled (Figure 3)		0.15		UI
Parallel Data-Input Setup Time	$t_{SET}$	(Figure 8)	2			ns

**AC Electrical Characteristics (continued)**

( $V_{DVDD} = V_{AVDD} = 1.7V$  to  $1.9V$ ,  $V_{IOVDD} = 1.7V$  to  $3.6V$ ,  $R_L = 100\Omega \pm 1\%$  (differential),  $T_A = -40^\circ C$  to  $+115^\circ C$ , EP connected to PCB ground, typical values are at,  $V_{DVDD} = V_{AVDD} = V_{IOVDD} = 1.8V$ ,  $T_A = +25^\circ C$ , unless otherwise noted.) (Note 1)

PARAMETER	SYMBOL	CONDITIONS	MIN	TYP	MAX	UNITS
Parallel Data Input Hold Time	$t_{HOLD}$	(Figure 8) (Note 4)	1			ns
GPI-to-GPO Delay	$t_{GPIO}$	Deserializer GPI to serializer GPO (Figure 9)			350	$\mu s$
Serializer Delay	$t_{SD}$	Spread spectrum enabled (Figure 10) (Notes 4, 7)			2065	Bits
		Spread spectrum disabled (Figure 10) (Notes 4, 7)			1095	
Link Start Time	$t_{LOCK}$	(Figure 11)			2	ms
Power-Up Time	$t_{PU}$	(Figure 12)			7	ms

**Note 1:** Limits are 100% production tested at  $T_A = +115^\circ C$ . Limits over the operating temperature range are guaranteed by design and characterization, unless otherwise noted.

**Note 2:** To provide a mid-level voltage, leave the input open; or, if driven, put the driver in high-impedance state. High-impedance leakage current must be less than  $\pm 10\mu A$ .

**Note 3:**  $I_{IJN}$  min is due to voltage drop across the internal pullup resistor.

**Note 4:** Not production tested. Guaranteed by design.

**Note 5:** Specified pin to ground.

**Note 6:** Specified pin to all supply/ground.

**Note 7:** Measured in serial link bit times. Bit time =  $1/(30 \times f_{PCLKIN})$  for BWS = 0; bit time =  $1/(40 \times f_{PCLKIN})$  for BWS = 1.

**Typical Operating Characteristics**

( $V_{AVDD} = V_{DVDD} = V_{IOVDD} = 1.8V$ ,  $T_A = +25^\circ C$ , unless otherwise noted.)

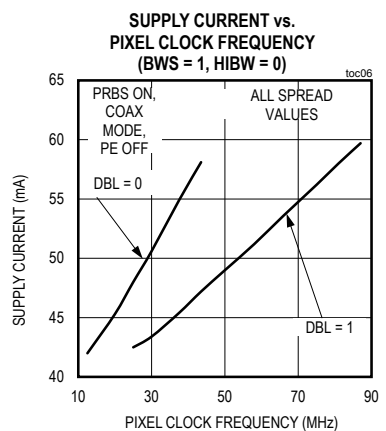
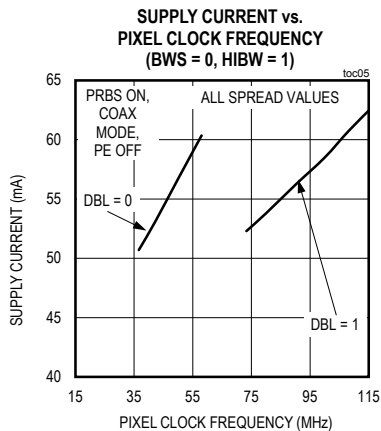
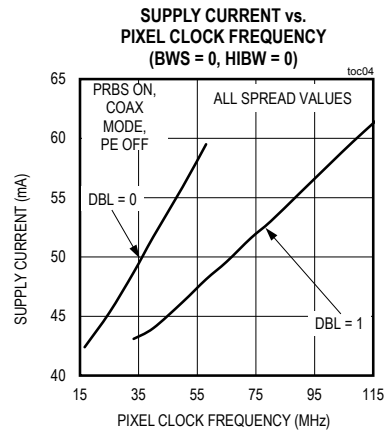
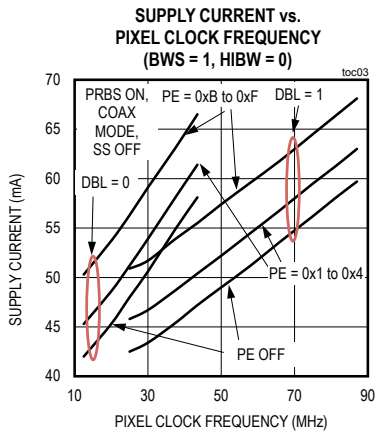
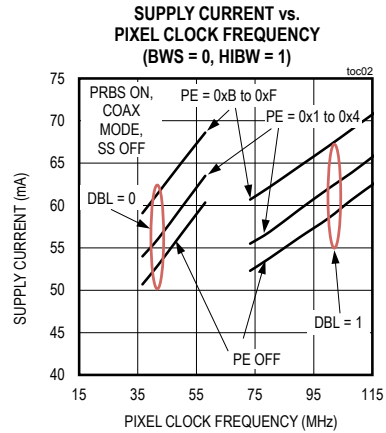
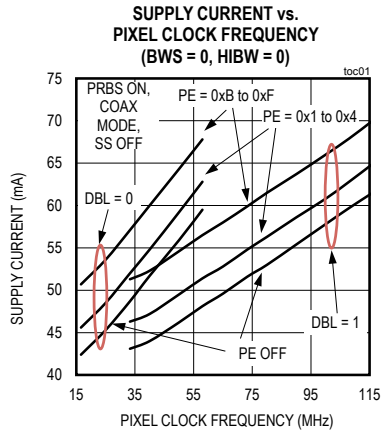

Typical Operating Characteristics (continued)

( $V_{AVDD} = V_{DVDD} = V_{IOVDD} = 1.8V$ ,  $T_A = +25^\circ C$ , unless otherwise noted.)

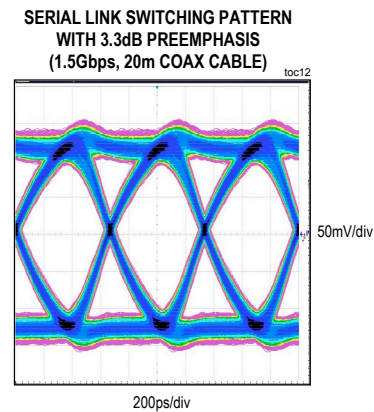
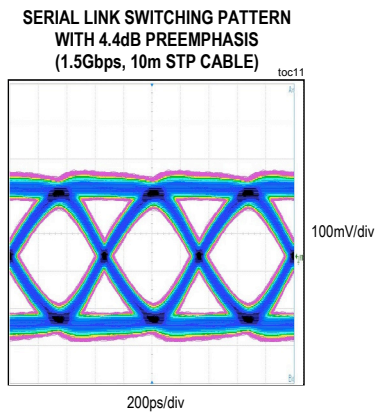
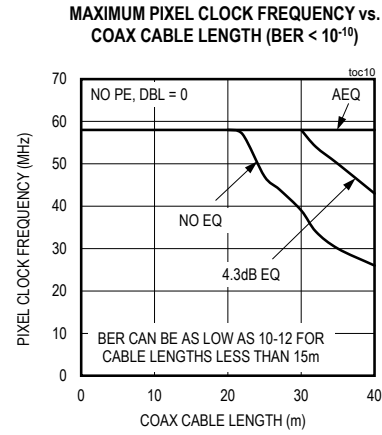
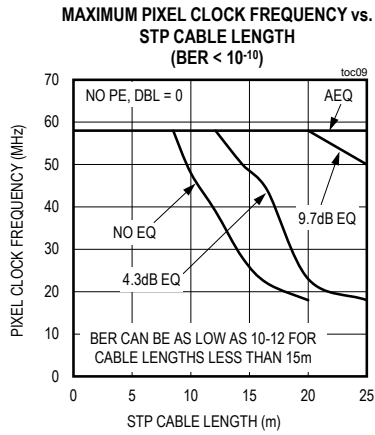
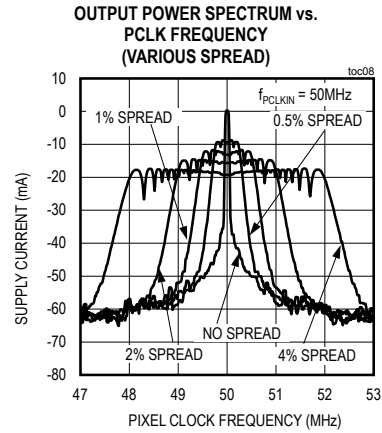
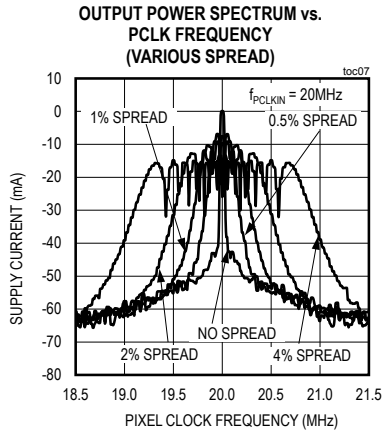

Pin Configuration

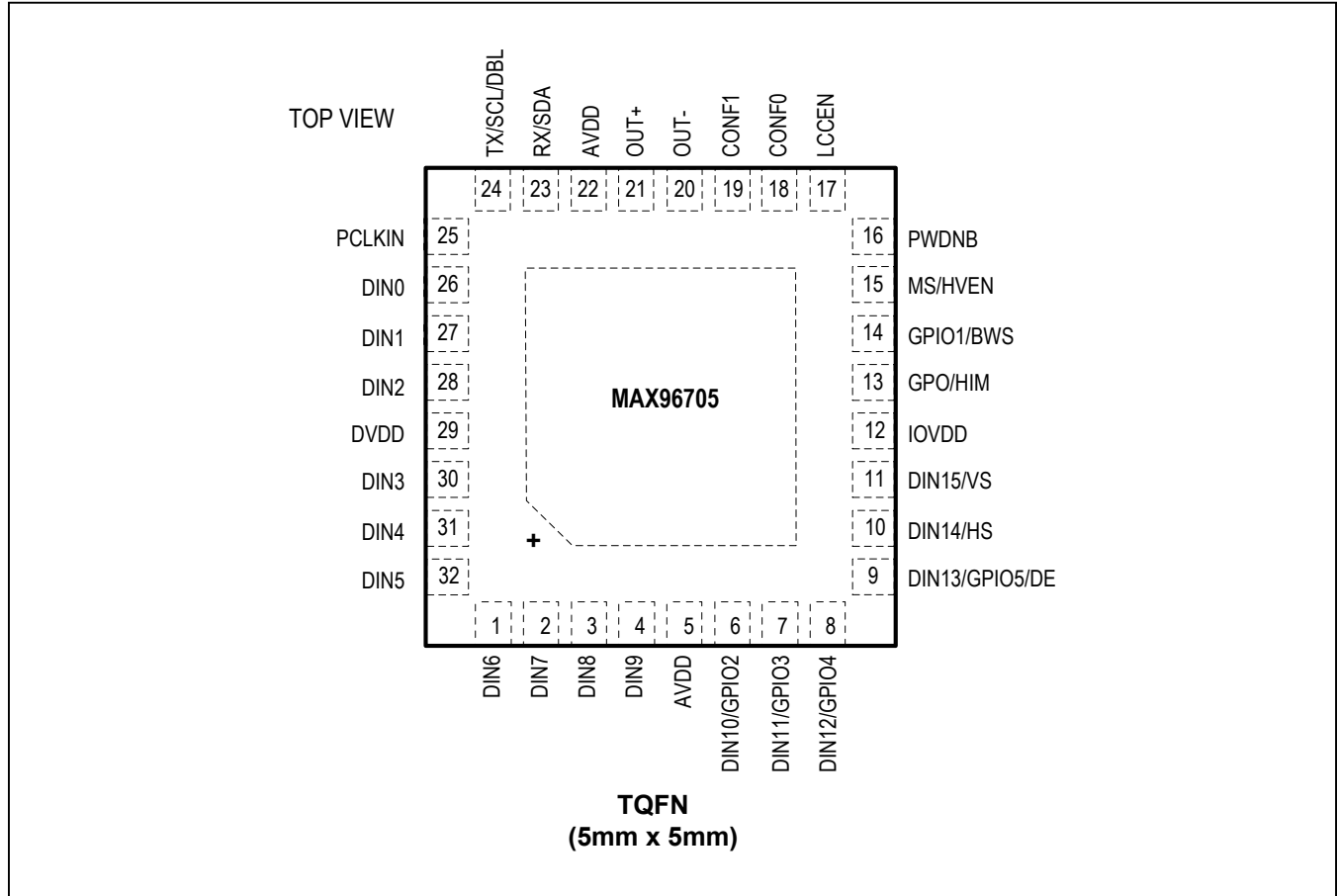

Pin Description

PIN	NAME	FUNCTION	REF SUPPLY	TYPE
<b>POWER</b>				
5, 22	AVDD	1.8V Analog Power Supply. Bypass AVDD to EP with 0.1µF, and 0.001µF capacitors as close as possible to the device with the smaller value capacitor closest to AVDD.		Power
12	IOVDD	I/O Supply Voltage. 1.8V to 3.3V logic I/O power supply. Bypass IOVDD to EP with 0.1µF and 0.001µF capacitors as close as possible to the device with the smaller value capacitor closest to IOVDD.		Power
29	DVDD	1.8V Digital Power Supply. Bypass DVDD to EP with 0.1µF, and 0.001µF capacitors as close as possible to the device with the smaller value capacitor closest to DVDD.		Power
EP	—	Exposed Pad. EP is internally connected to device ground. Must connect EP to the PCB ground plane through a via array for proper thermal and electrical performance.		Power

## Pin Description (continued)

PIN	NAME	FUNCTION	REF SUPPLY	TYPE
<b>HIGH-SPEED DIGITAL</b>				
<b>Single Function</b>				
1	DIN6	Parallel Data Input. Internal pulldown to EP.	IOVDD	Digital
2	DIN7	Parallel Data Input. Internal pulldown to EP.	IOVDD	Digital
3	DIN8	Parallel Data Input. Internal pulldown to EP.	IOVDD	Digital
4	DIN9	Parallel Data Input. Internal pulldown to EP.	IOVDD	Digital
25	PCLKIN	Parallel Clock Input with Internal Pulldown to EP. Latches parallel data inputs and provides the PLL reference clock.	IOVDD	Digital
26	DIN0	Parallel Data Input. Internal pulldown to EP.	IOVDD	Digital
27	DIN1	Parallel Data Input. Internal pulldown to EP.	IOVDD	Digital
28	DIN2	Parallel Data Input. Internal pulldown to EP.	IOVDD	Digital
30	DIN3	Parallel Data Input. Internal pulldown to EP.	IOVDD	Digital
31	DIN4	Parallel Data Input. Internal pulldown to EP.	IOVDD	Digital
32	DIN5	Parallel Data Input. Internal pulldown to EP.	IOVDD	Digital
<b>Multifunction</b>				
6	DIN10/GPIO2	Parallel Data Input/GPIO. Defaults to parallel data input on power-up. Parallel data input has internal pulldown to EP. GPIO2 has an open-drain input/output with internal 60kΩ pullup to IOVDD.	IOVDD	Digital
7	DIN11/GPIO3	Parallel Data Input/GPIO. Defaults to parallel data input on power-up. Parallel data input has internal pulldown to EP. GPIO3 has an open-drain input/output with internal 60kΩ pullup to IOVDD.	IOVDD	Digital
8	DIN12/GPIO4	Parallel Data Input/GPIO. Defaults to parallel data input on power-up. Parallel data input has internal pulldown to EP. GPIO4 has an open-drain input/output with internal 60kΩ pullup to IOVDD.	IOVDD	Digital
9	DIN13/ GPIO5/DE	Parallel Data Input/GPIO/Data Enable with Internal Pulldown to EP. Defaults to parallel data input on power-up. GPIO5 has an open-drain input/output with internal 60kΩ pullup to IOVDD. Data enable input in high-bandwidth mode.	IOVDD	Digital
10	DIN14/HS	Parallel Data Input/Horizontal Sync with Internal Pulldown to EP. Defaults to parallel data input on power-up. Defaults to horizontal-sync input when HS/VS encoding is enabled, or when in high-bandwidth mode.	IOVDD	Digital
11	DIN15/VS	Parallel Data Input/Vertical Sync with Internal Pulldown to EP. Defaults to parallel data input on power-up. Defaults to vertical-sync input when HS/VS encoding is enabled, or when in high-bandwidth mode.	IOVDD	Digital
<b>Multifunction Configuration (from LCCEN)</b>				
14	GPIO1/BWS	GPIO1/Bus-Width Select Input. Function is determined by the state of LCCEN. GPIO1 (LCCEN = high): Open-drain, general-purpose input/output with internal 60kΩ pullup to IOVDD. BWS (LCCEN = low): Input with internal pulldown to EP. Set BWS = low for 22-bit input latch. Set BWS = high for 30-bit input latch.	IOVDD	Digital



## Pin Description (continued)

PIN	NAME	FUNCTION	REF SUPPLY	TYPE
15	MS/HVEN	Mode-Select/HS and VS Encoding Enable Input with Internal Pulldown to EP. Function is determined by the state of LCCEN. MS (LCCEN high): Set MS low to select base mode. Set MS high to select bypass mode. HVEN: (LCCEN low): Set HVEN = high to enable HS/Vs encoding. Set HVEN = low to disable HS/Vs encoding.	IOVDD	Digital
17	LCCEN	Local Control-Channel Enable input with internal Pulldown to EP. LCCEN = high enables the control-channel interface pins. LCCEN = low disables the control-channel interface pins and selects an alternate function on the indicated pins.	IOVDD	Digital
24	TX/SCL/DBL	Transmit/Serial Clock/Double Mode. Function is determined by the state of LCCEN. TX/SCL (LCCEN = high): Input/output with internal 30kΩ pullup to IOVDD. In UART mode, TX/SCL is the Tx output of the serializer's UART. In I <sup>2</sup> C mode, TX/SCL is the SCL input/output of the serializer's I <sup>2</sup> C master/slave. TX/SCL has an open-drain driver and requires a pullup resistor. DBL (LCCEN = low): Input with internal pulldown to EP. Set DBL = high to use double-input mode. Set DBL = low to use single-input mode.	IOVDD	Digital
<b>Configuration and Interface</b>				
13	GPO/HIM	General-Purpose Output/High-Immunity Mode Input with internal Pulldown to EP. HIM is latched at power-up or when resuming from power-down mode (PWDNB = low), and switches to GPO output automatically after power-up. Connect HIM to IOVDD with a 30kΩ resistor to set high, or leave open to set low. HIGHIMM can be programmed to a different value after power-up. HIGHIMM in the deserializer must be set to the same value. GPO output follows the state of the GPI (or INT) input on the GMSL deserializer. GPO is low upon power-up or when PWDNB is low.	IOVDD	Digital
16	PWDNB	Active-Low, Power-Down Input with Internal Pulldown to EP. To reduce power consumption, set PWDNB low to enter power-down mode.	IOVDD	Digital
18	CONF0	Configuration 0. Three-level configuration input (Table 13). CONF0 pin value is latched at power-up, or when resuming from power-down mode.	IOVDD	3-Level
19	CONF1	Configuration 1. Three-level configuration input (Table 13). CONF1 pin value is latched at power up or when resuming from power-down mode.	IOVDD	3-Level
20	OUT-	Inverting Coax/Twisted-Pair Serial Output.		Digital
21	OUT+	Noninverting Coax/Twisted-Pair Serial Output		Digital
23	RX/SDA	Receive/Serial Data. Input/output with internal 30kΩ pullup to IOVDD. In UART mode, RX/SDA is the Rx input of the serializer's UART. In I <sup>2</sup> C mode, RX/SDA is the SDA input/output of the serializer's I <sup>2</sup> C master/slave. RX/SDA has an open-drain driver and requires a pullup resistor.	IOVDD	Digital

Functional Block Diagram

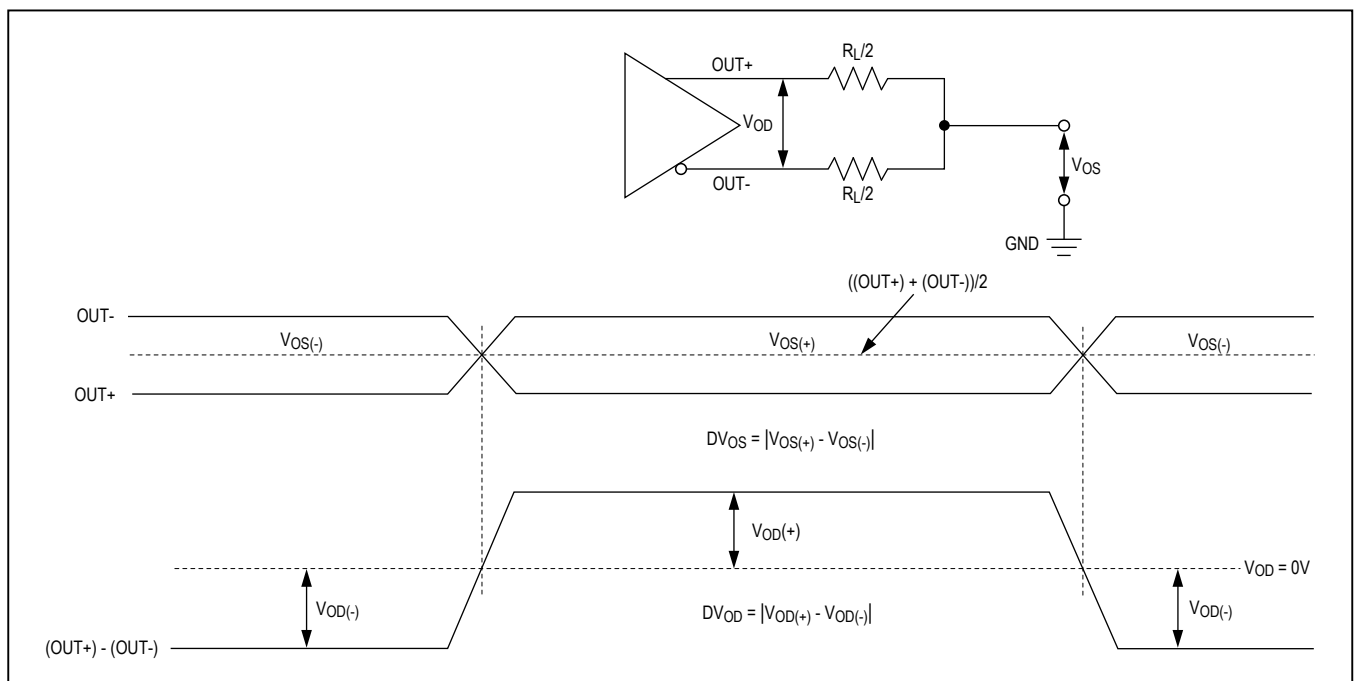
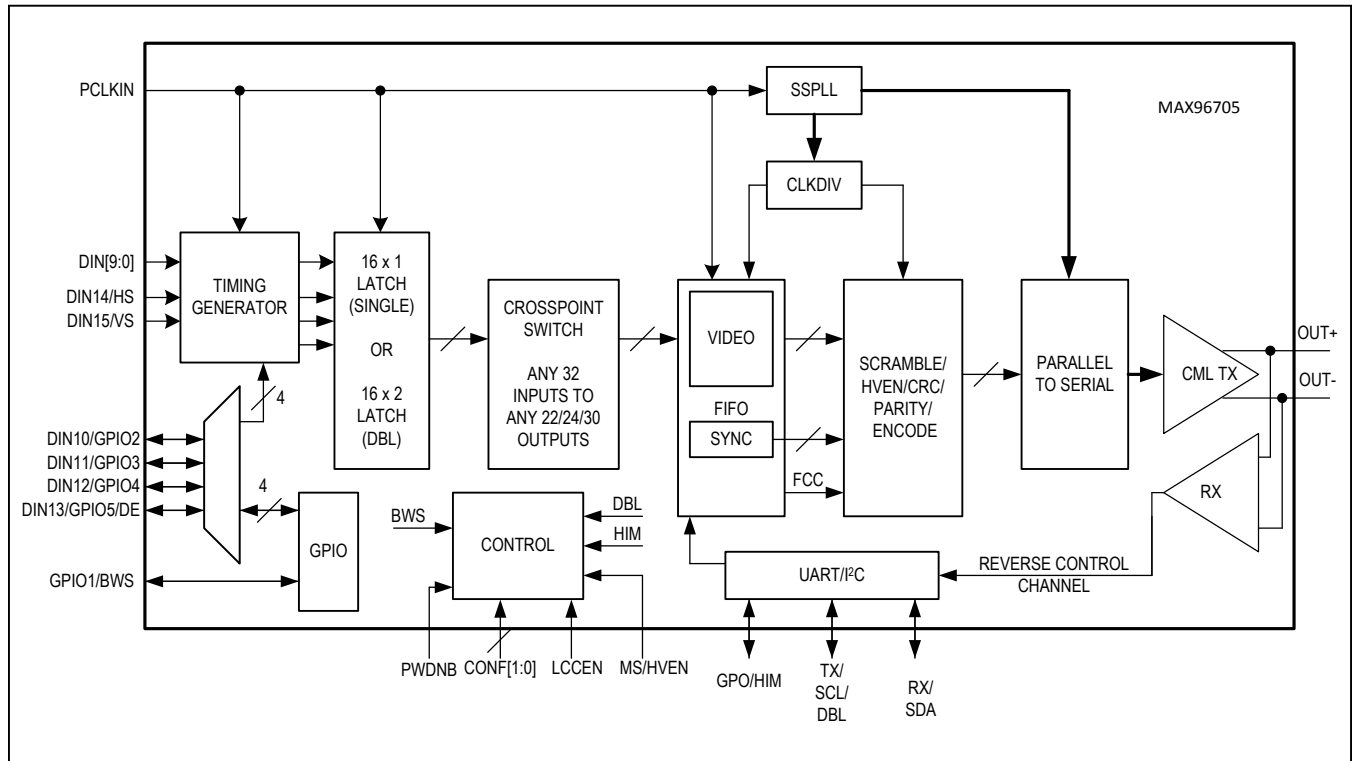

Figure 1. Serial-Output Parameters

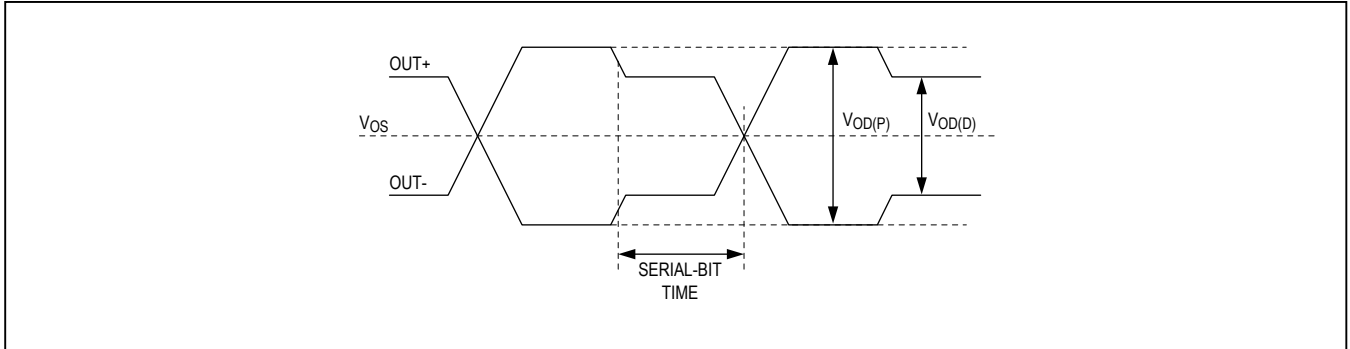

Figure 2. Output Waveforms at OUT+, OUT-

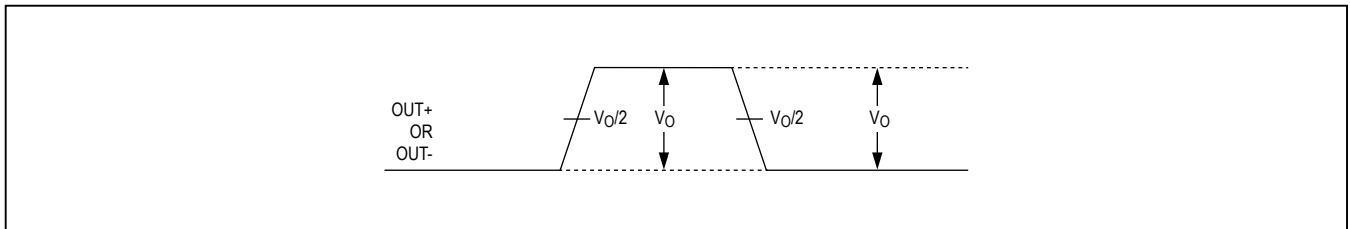

Figure 3. Single-Ended Output Template

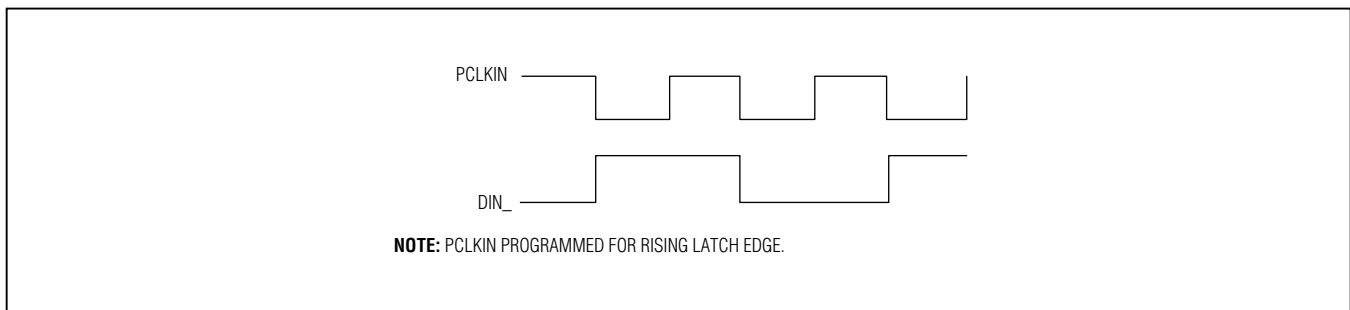

Figure 4. Worst-Case Pattern Input

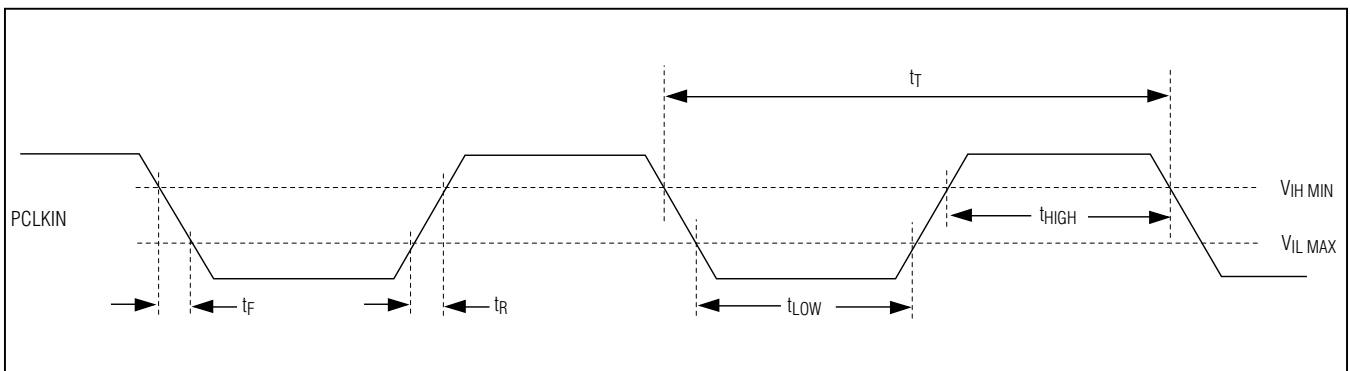

Figure 5. Parallel Clock Input Requirements

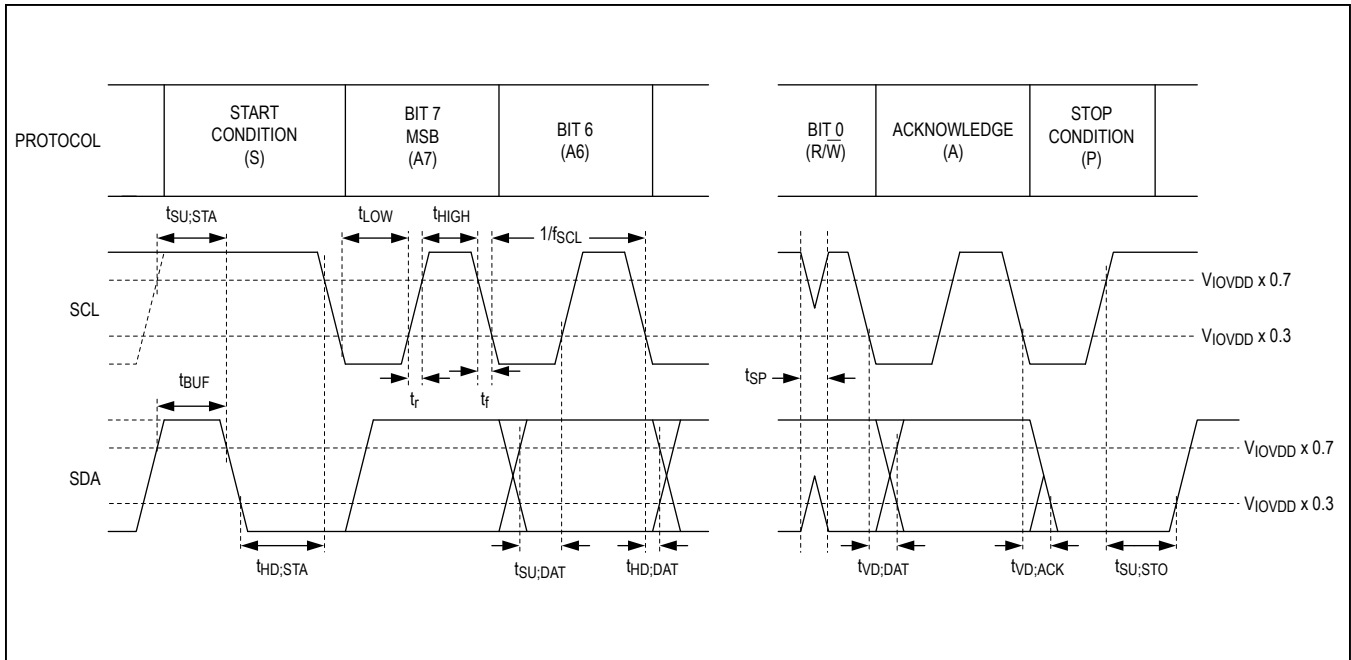

Figure 6. I<sup>2</sup>C Timing Parameters

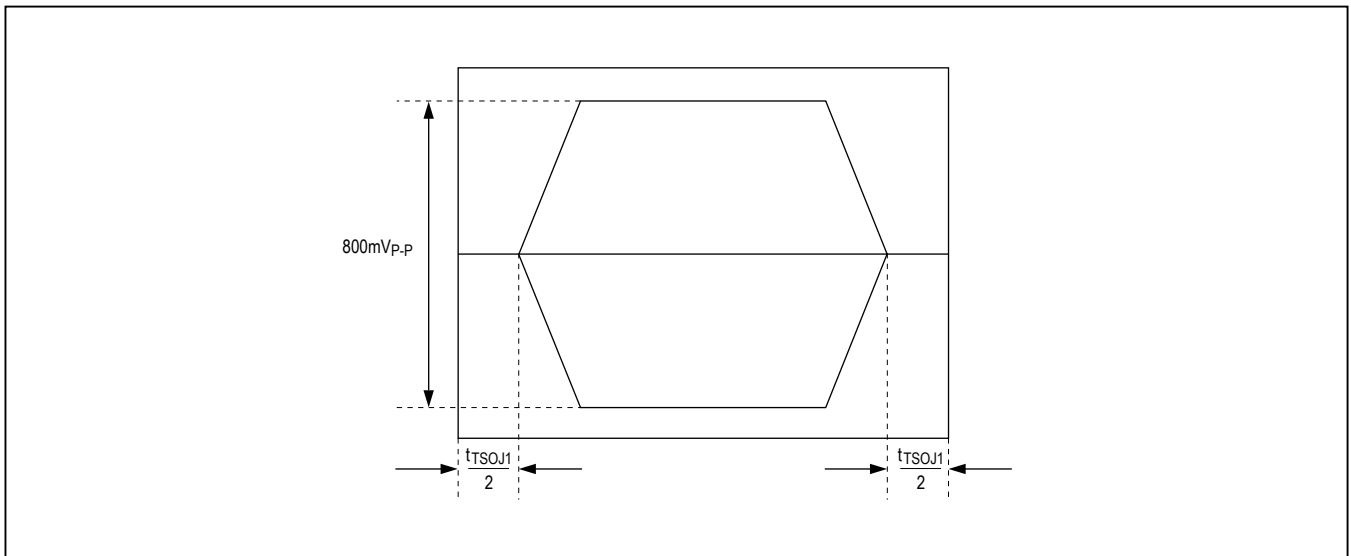

Figure 7. Differential Output Template

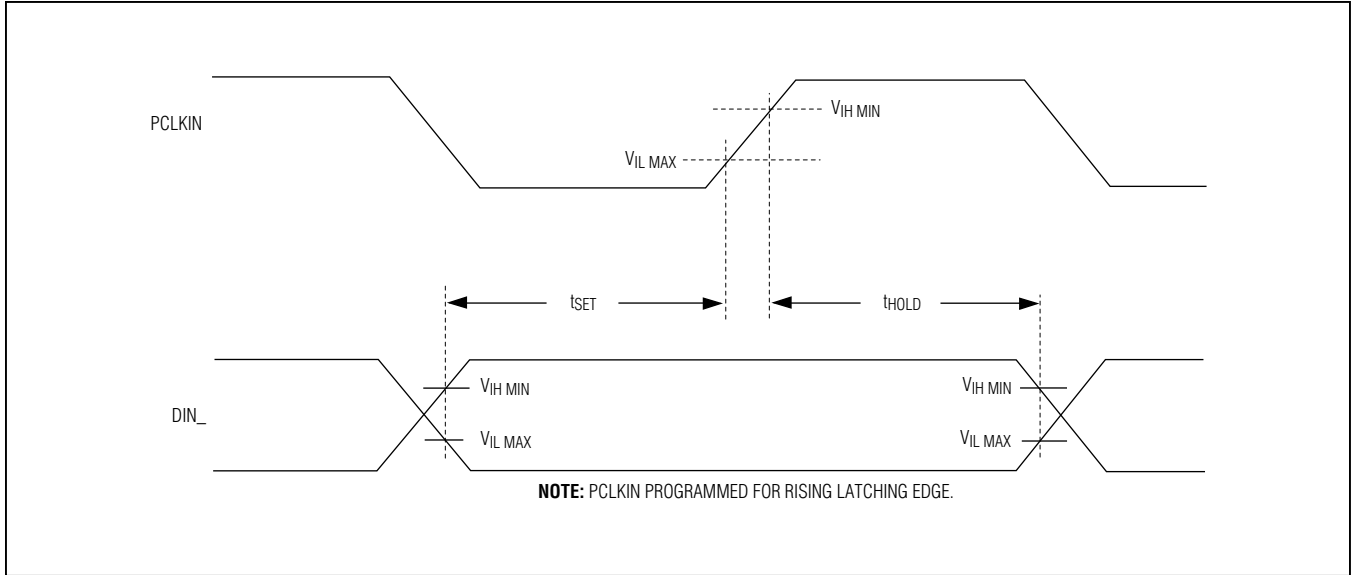

Figure 8. Input Setup and Hold Times

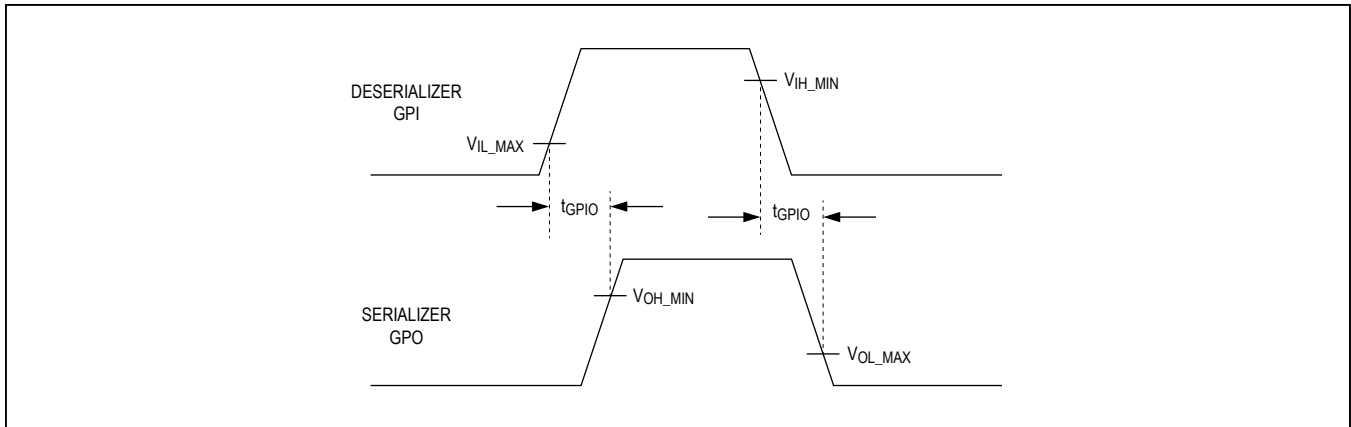

Figure 9. GPI-to-GPO Delay

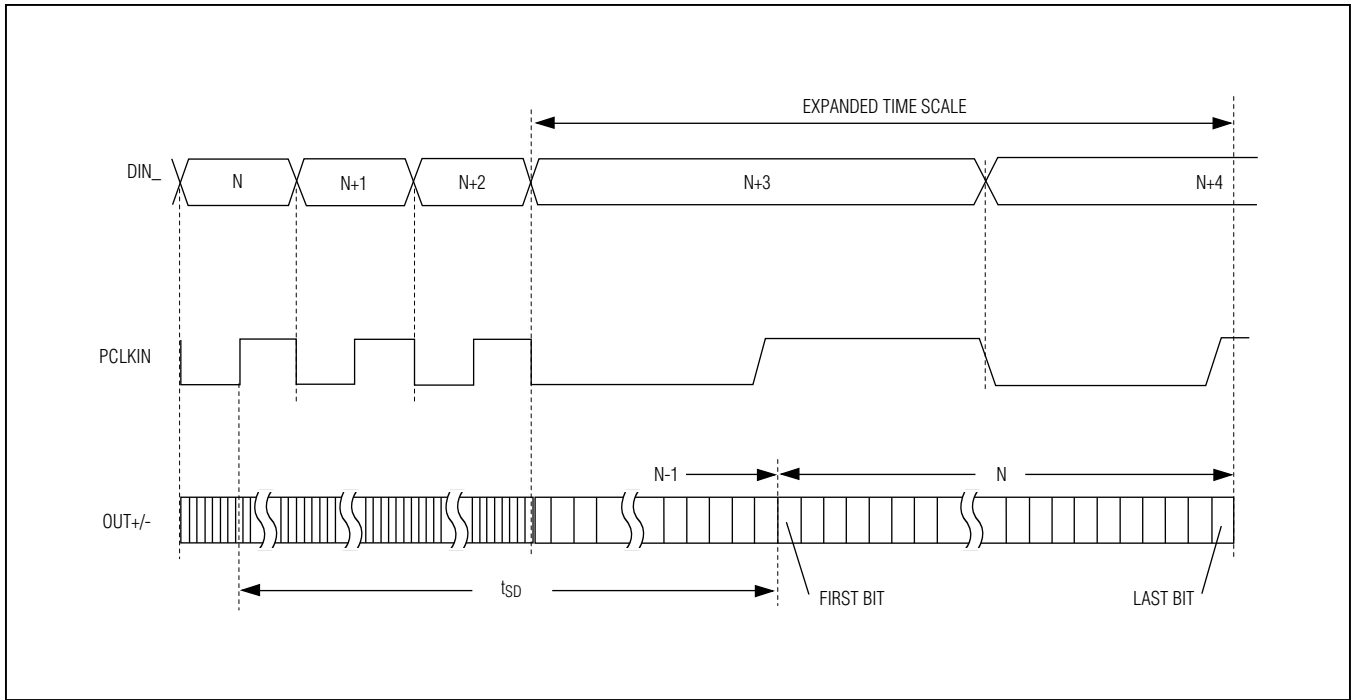

Figure 10. Serializer Delay

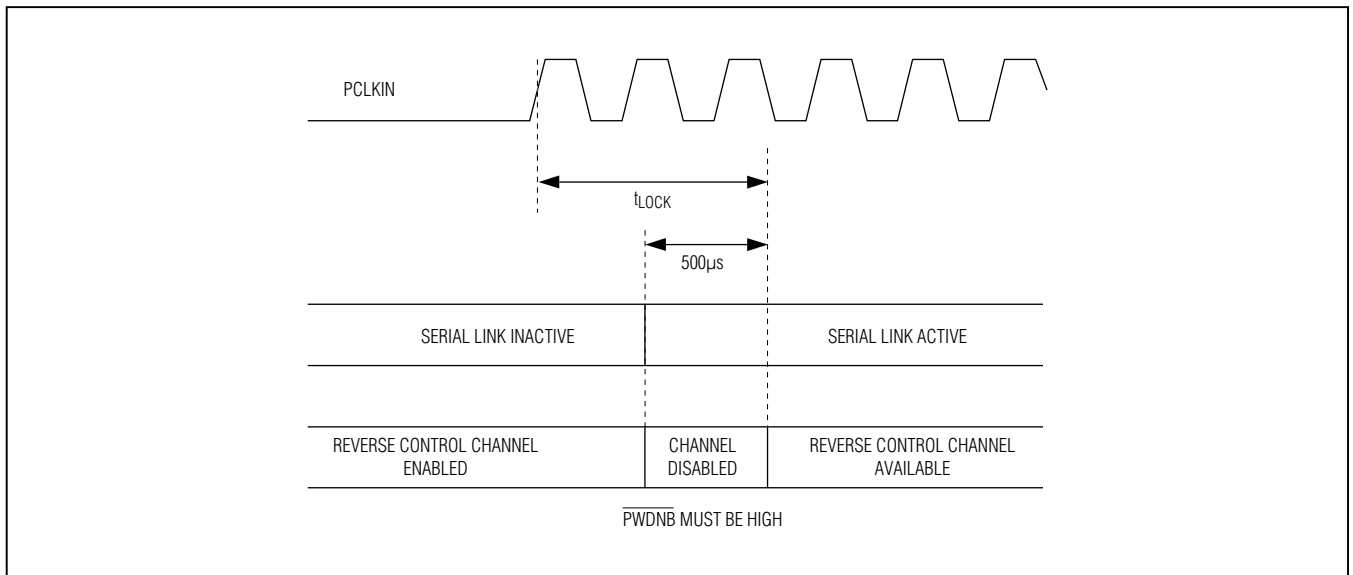

Figure 11. Link Startup Time

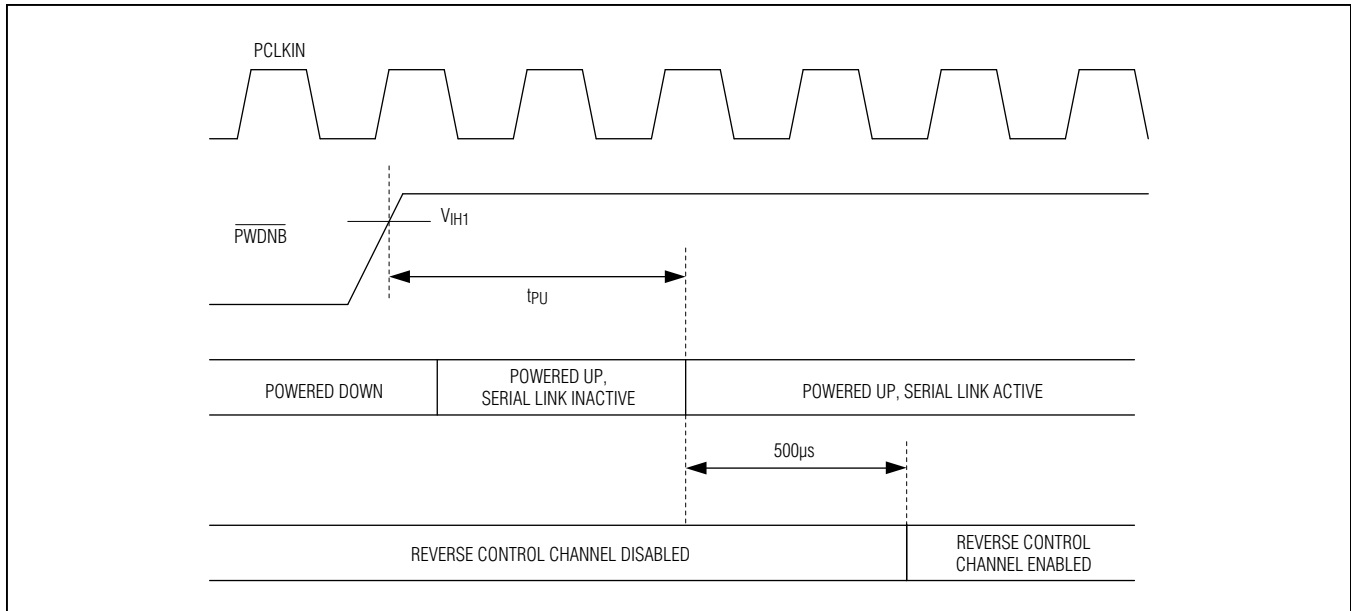

Figure 12. Power-Up Delay

## Detailed Description

The MAX96705 is a compact device with features especially suited for automotive camera applications. The device operates at a variety of input widths and word rates up to a total serial-data rate up to 1.74Gbps. High-bandwidth mode offers a 116MHz parallel clock rate with 12 bits of video data and 2 bits of sync (HS/VS) data. An embedded 9.6kbps to 1Mbps control channel programs the serializer, deserializer, and any attached UART or I<sup>2</sup>C peripherals.

To promote safety applications, the device features CRC protection of video and control data. In addition, control-channel retransmission and high-immunity modes reduce the effects of bit errors corrupting communication. Preemphasis and a PRBS tester allow for in-system evaluation and optimization of the link quality.

This MAX96705 operates over the -40°C to +115°C automotive temperature range.

### Serial Link Signaling and Data Format

The serializer scrambles the input parallel data and combines this with the forward control data. The data is then encoded for transmission and output as a single-serialized bitstream at several times the input word rate (depending on bus width). The deserializer receives the serial data and recovers the clock signal. The data is then deserialized, decoded, and descrambled into parallel output data and forward control data.

## Operating Modes

The GMSL devices are configurable to operate in many modes depending on the application. These modes allow for a more efficient use of serial bandwidth. Most of these settings are set during system design, and are configured using the external configuration pins or through register bits.

### Video/Configuration Link

In normal operation, the serializer runs in video link mode (serializer SEREN = 1) with video data and control data sent across the serial link. Set SEREN = 0 in the serializer to turn off serialization. The serializer powers up in video link mode and requires a valid PCLK for operation.

A configuration link is available to set up the serializer, deserializer, and peripherals when PCLK is not available. Set SEREN = 0 and CLINK = 1 in the serializer to enable the configuration link (SEREN = 1 forces the serializer into video link mode). Once PCLK has been established, turn on the video link (SEREN = 1).

By default, video link mode requires a valid PCLK for operation. Set AUTO\_CLINK bit = 1 and SEREN = 1 in the serializer to have the device automatically switch between the video link and configuration link whenever PCLK is not present.

### Single/Double Mode

Single-/double-mode operation configures the available 1.74Gbps bandwidth into a variety of widths and word rates. Single-mode operation is compatible with all GMSL devices and serializers, yielding one parallel word for each serial word. Double mode serializes two half-width parallel words for each serial word, resulting in a 2x increase in the parallel word rate range (compared to single mode). Set DBL = 0 for single-mode operation and DBL = 1 for double-mode operation.

### HS/VS Encoding

By default, GMSL assigns a video bit slot to HSYNC, VSYNC, and DE (if used). With HS/VS encoding, the device instead encodes special packets to sync signals to free up additional video bit slots. HS/VS encoding is on by default when the device is in high-bandwidth mode (HIBW = 1). DE is encoded only when HIBW = 1 and DE\_EN = 1. Set HVEN = 1 to turn on HS/VS encoding when HIBW = 0 (DE, if enabled, uses up a video bit). HS/VS encoding requires that HSYNC, VSYNC, and DE (if used) remain high during the active video and low during the blanking period. Use HS/VS inversion when using reverse-polarity sync signals.

### Error Detection

The serial link's 8b/10b encoding/decoding and 1-bit parity detect bit errors that occur on the serial link. An optional 6-bit CRC check is available at the expense of 6 video bits (when HIBW = 0). To activate 6-bit CRC mode, set PXL\_CRC = 1 in the remote-side device first, then in the local-side device. When using 6-bit CRC mode, the available internal bus width is reduced by 6 bits in single-input mode (DBL = 0) and 3 bits in double-input mode (DBL = 1). Note that the input bus width may already have been reduced due to pin availability of the serializer or deserializer; thus, the reduction of bandwidth from CRC may not be visible (see [Table 3](#)).

An additional 32-bit video line CRC is available by setting LINE\_CRC\_EN = 1. When enabled, the serializer calculates the 32-bit CRC of the video line and sends this information during the blanking period. The deserializer compares the received CRC with the video line data. The deserializer's LINE\_CRC\_ERR bit latches when a CRC error is detected. LINE\_CRC\_ERR clears when read.

### Bus Widths

The serial link has multiple bus-width settings that determine the parallel bus width and the resulting parallel word rate. The serial link operates to a maximum serial bit rate of 1.74Gbps. The BWS bit determines if each serial packet is 30 or 40 bits long, which translates to a maximum serial packet rate (and resulting maximum parallel word rate) of 58MHz or 43.5MHz when BWS = 0 or 1 respectively. Encoding translates the 24, 27, or 32 parallel bits into 30- or 40-bit serial packets. One bit is used for parity, while a second is reserved for the control channel. An additional 6 bits are used during optional 6-bit CRC. In addition, double mode splits the remaining word size in half, if used. The remaining bits can be used for video bits (minus any sync bits if H/V encoding is not used).

The following modes list the internal bus widths. The number of available input and output pins may limit the actual bus width available.

- **24-Bit Mode** ([Figure 13](#))

When BWS = 0 and HIBW = 0, the 30-bit serial packet corresponds with three 8b/10b symbols representing 24 bits (24-bit mode). After the parity and control channel, this leaves 16/22 bits of video data if CRC is/ or is not used (single mode), or 8/11 bits of video data if CRC is/ or is not used (double mode).

- **27-Bit High-Bandwidth Mode** ([Figure 14](#))

When BWS = 0 and HIBW = 1 (high-bandwidth mode), the 30-bit serial packet represents three 9b/10b symbols representing 27 bits. After the parity and control channel, this leaves 19/25 bits of video data if CRC is/ or is not used (single mode), or 9/12 bits of video data if CRC is/ or is not used (double mode).

- **32-Bit Mode** ([Figure 15](#))

When BWS = 1, the 40-bit serial packet corresponds with four 8b/10b symbols representing 32 bits (32-bit mode). After parity and control channel, this leaves 24/30 bits of video data if CRC is/ or is not used (single mode), or 12/15 bits of video data if CRC is/ or is not used (double mode).



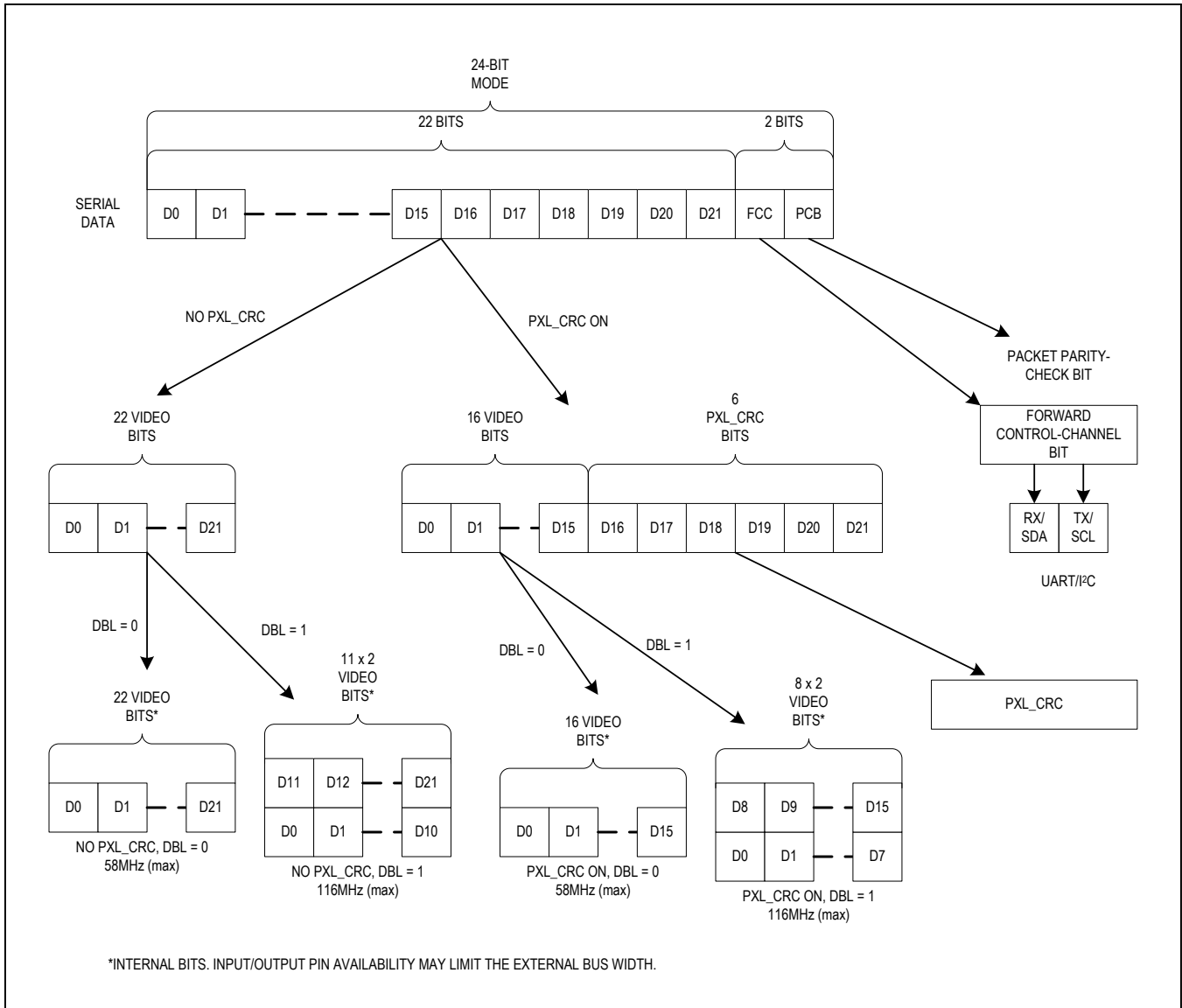

Figure 13. 24-Bit Mode Serial-Data Format

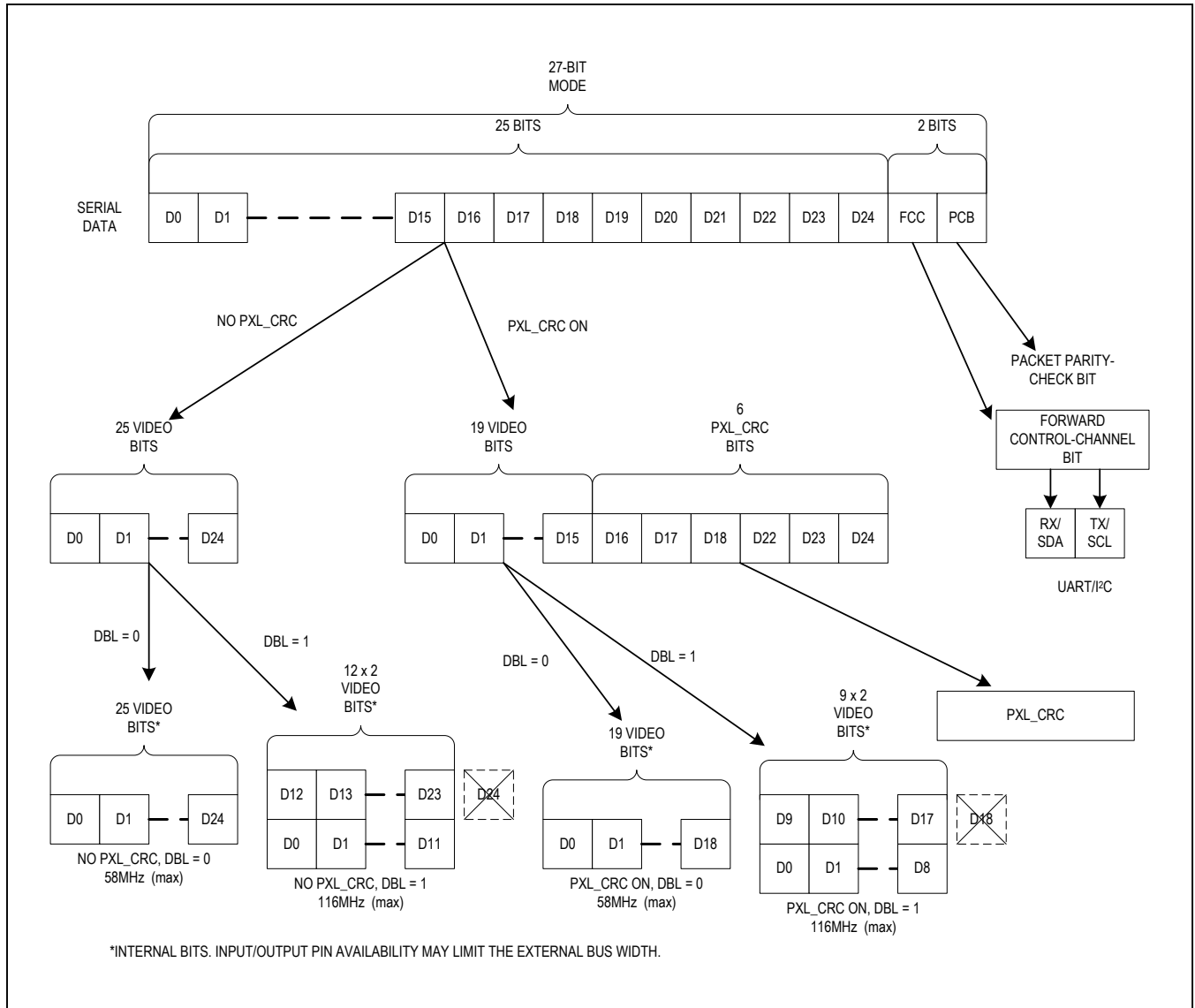

Figure 14. 27-Bit High-Bandwidth Mode Serial-Data Format

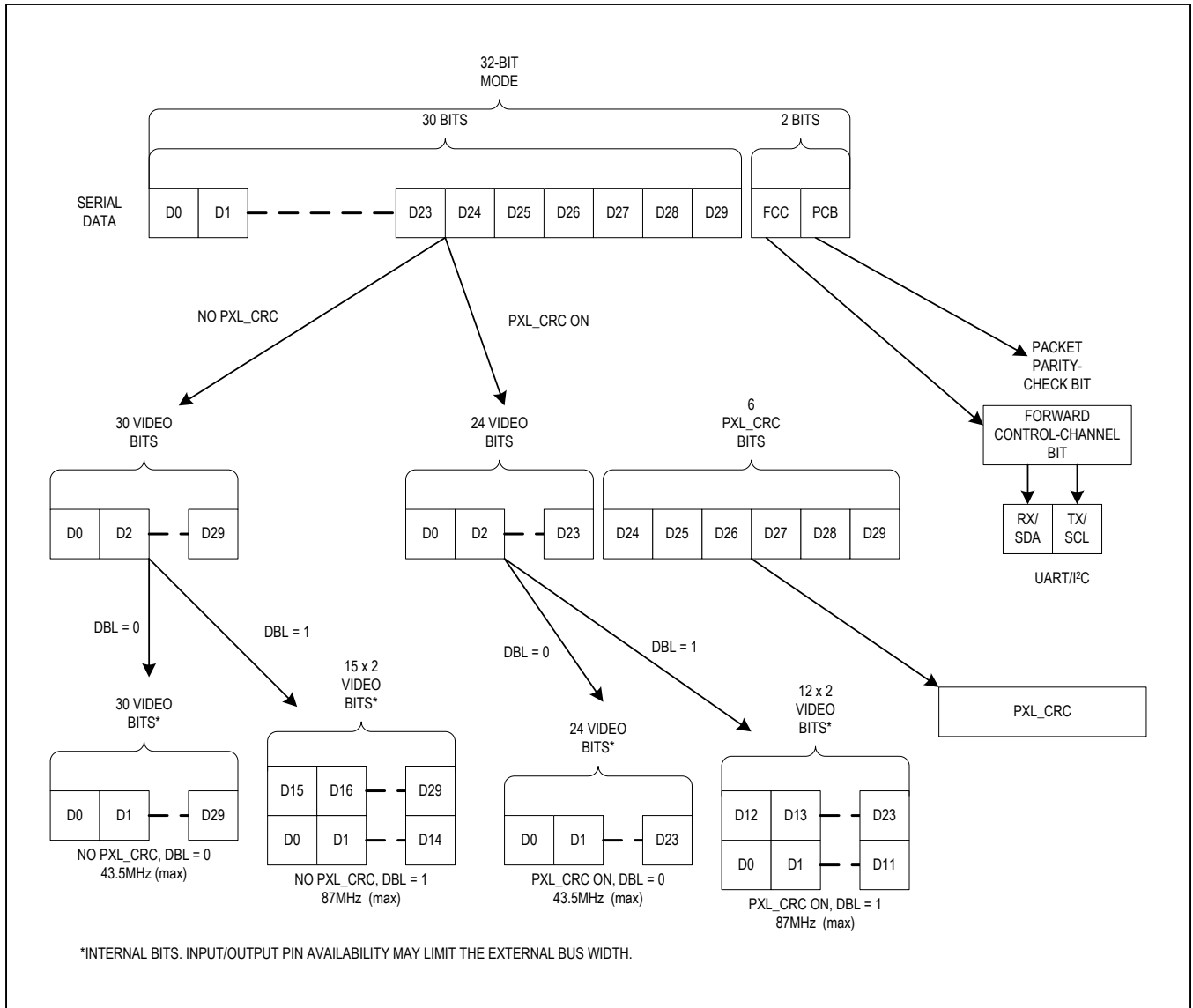

Figure 15. 32-Bit Mode Serial-Data Format

### Control Channel and Register Programming

The control channel sends information across the serial link for control of the serializer, deserializer, and any attached peripherals. The control channel is multiplexed onto the serial link and is available with or without the video channel.

#### Forward Control Channel

Control data sent from the serializer to the deserializer is sent on the forward control channel. The data is encoded as one of the serial bits in the forward high-speed link. After deserialization, the forward control-channel data is extracted from the serial link. The forward control-channel bandwidth exceeds the maximum external control data rate, and all data sent on the forward control channel appears on the remote side after transmission delay of a few bit times.

#### Reverse Control Channel

Control data sent from the deserializer to the serializer is sent on the reverse control channel. The data is encoded as a series of 1 $\mu$ s pulses, with a maximum raw data rate of 1Mbps. High-immunity mode is available to increase the robustness of the reverse control channel at a reduced raw bit rate of 500kbps. In [Table 1](#), setting the REV\_FAST bit = 1 increases this rate back to 1Mbps. In I<sup>2</sup>C mode, when the input data rate (after encoding) exceeds the reverse data rate, the input clock is held through clock stretching to slow the external clock to match the internal bit rate.

#### UART Interface

The UART interface, compatible with all GMSL devices, sends commands from device to device through several UART packets. Two modes are available: base mode and bypass mode. Base mode is used to communicate with the serializer, deserializer, and to I<sup>2</sup>C peripherals using UART-to-I<sup>2</sup>C translation. Bypass mode allows for full-duplex UART communication to peripherals using any UART protocol.

**Table 1. Reverse Control-Channel Modes**

HIM PIN SETTING	REVFASST BIT	REVERSE CONTROL-CHANNEL MODE	MAXIMUM UART/I <sup>2</sup> C BIT RATE (KBPS)
Low	X	Legacy reverse control-channel mode (compatible with all GMSL devices)	1000
High	0	High-immunity mode	500
	1	Fast high-immunity mode (requires HIBW = 0, serial-data rate > 1.25Gbps)	1000

X = Don't care.

### I<sup>2</sup>C Interface

The serial link connects the serializer and deserializer I<sup>2</sup>C interfaces together through the control channel. When an I<sup>2</sup>C master sends a command to one side of the link (local side) the control channel forwards this information to and from the other side of the link (remote side), allowing a single microcontroller to configure the serializer, deserializer, and peripherals. The microcontroller can be located on the serializer side (display applications) and the deserializer side (camera applications). Dual microcontroller operations are supported as long as a software-arbitration method is used. The serial link assumes that only one microcontroller is talking at any given time.

#### Remote-End Operation

When an I<sup>2</sup>C master initiates communication on the local slave device (the serializer/deserializer directly connected to the master), the remote-side device acts as a master device that sends data forwarded from the local-side device, and forwards any data received from peripherals attached to the remote-side device. This remote-side master device operates according to the timing settings in the I<sup>2</sup>C master setting register. Set the master settings to match the timing settings used by the external microcontroller.

#### Clock-Stretch Timing

The I<sup>2</sup>C interface uses clock stretching to allow time for data to be forwarded across the serial link. The master microcontroller, along with any attached peripherals, must accept clock stretching of the GMSL devices.

#### Packet-Based I<sup>2</sup>C

A packet-based control channel is available for enhanced error handling of the control channel. This control-channel method handles simultaneous GPI/GPO and I<sup>2</sup>C transmission, along with error detection and retransmission.

### Packet Protocol Summary

The packet-based control channel uses a synchronous, symbol-based system to send data across the control channel. Data to be sent across the control channel is split into symbols and stored in a transmit queue and then sent across the link. If both GPI and I<sup>2</sup>C data needs to be sent (e.g., when GPI transitions during an I<sup>2</sup>C transmission), the symbols from both commands are combined in the queue. If the transmit queue is empty, idle packets are sent across the link to maintain control-channel lock. Received I<sup>2</sup>C packets are output as determined by the microcontroller SCL rate (local device) or the programmed master bit rate (remote device). The device holds SCL low (clock stretch) until data has been received from the remote-side device.

### Control-Channel Error Detection and Packet Retransmission

When the packet-based control channel is used, all packets are checked for errors through CRC. Using 1, 5, or 8 bits, CRC detects 1, 3, or 4 random bit errors in a packet. The transmitter retransmits packets whenever an error is detected. The transmitter sets a flag if a number of retries exceed a programmed threshold. The receiver filters out packets with errors.

### GPO/GPI Control

GPO on the serializer follows GPI transitions on the deserializer. This GPO/GPI function can be used to transmit signals such as a frame sync in a surround-view camera system (see the [Providing a Frame Sync \(Camera Applications\)](#) section). Optionally, GPO can be set directly by register bits.

### Spread Spectrum

The serializer contains a programmable spread-spectrum output to lower emission levels by spreading the clock-frequency peaks across a frequency spectrum. In addition, the serializer and deserializer can track a spread input clock, eliminating the need for multiple spread clocks.

### Cable Type Configuration

The driver output is programmable for two kinds of cable, 100Ω twisted pair and 50Ω coax (contact the factory for devices compatible with 75Ω cables). In coax mode, connect OUT+ to IN+ of the deserializer. Leave the unused IN<sub>-</sub> pin unconnected, or connect it to ground through 50Ω, and a capacitor for increased power-supply rejection. Connect OUT- to V<sub>DD</sub> through a 50Ω resistor (Figure 16).

### Crossbar Switch

The crossbar switch routes data between the parallel input/output and the SerDes. The anything-to-anything routing assures the mapping between the video source and destination. For each crossbar output (XBO<sub>-</sub>) an input multiplexer selects from the available crossbar inputs (XBI<sub>-</sub>) using the CROSSBAR<sub>-</sub> register bits (Figure 17). Multiple crossbar outputs can use the same crossbar input. By default, the sync signals share the same inputs as the MSBs of the video data.

### Video Timing Generator

The serializer includes a programmable video timing generator to generate/retime the input sync signals. The timing generator can be used to modify a camera's input timing, filter out glitches in the sync signals, or to reduce the number of required input sync signals. Each sync signal can be individually retimed or left unmodified. Several registers determine the length of the timing parameters (in PCLK cycles) shown in Figure 18. Timing parameters include high/low period length, line count, and delay from the input VS signal.

The timing generator uses three different trigger modes, tracking, single trigger, and autorun. Tracking mode looks at the input VSYNC and locks once it receives three consecutive identical VSYNC signals. The tracker then continues to output the same identical signal, erasing any glitches that may appear on VSYNC. The tracker attempts to relock to a new signal if three consecutive input waveforms do not match the locked signal. Single trigger generates one generated frame for each input VSYNC edge. Autorun generates a new frame at the rate determined by the VSYNC high/low period. If a new VSYNC signal appears before a frame is complete in either single trigger or autorun modes, a new frame immediately starts, cutting the previous frame short.

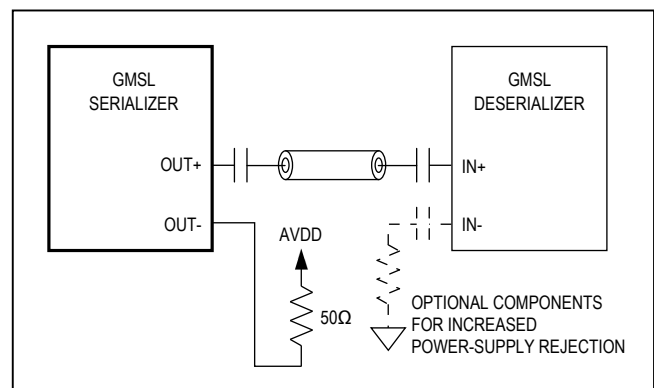

Figure 16. Coax Connection

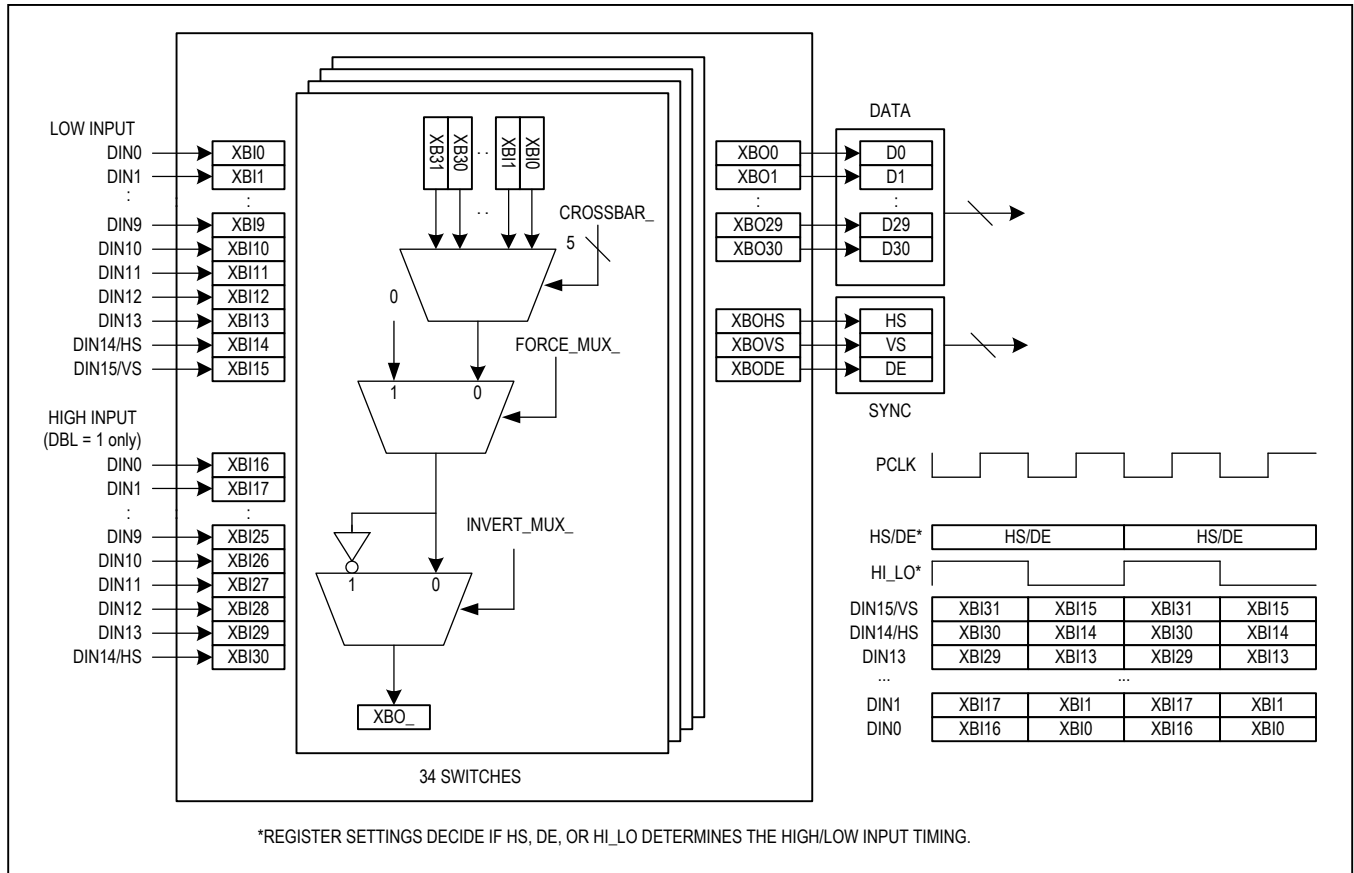

Figure 17. Crossbar Switch Dataflow

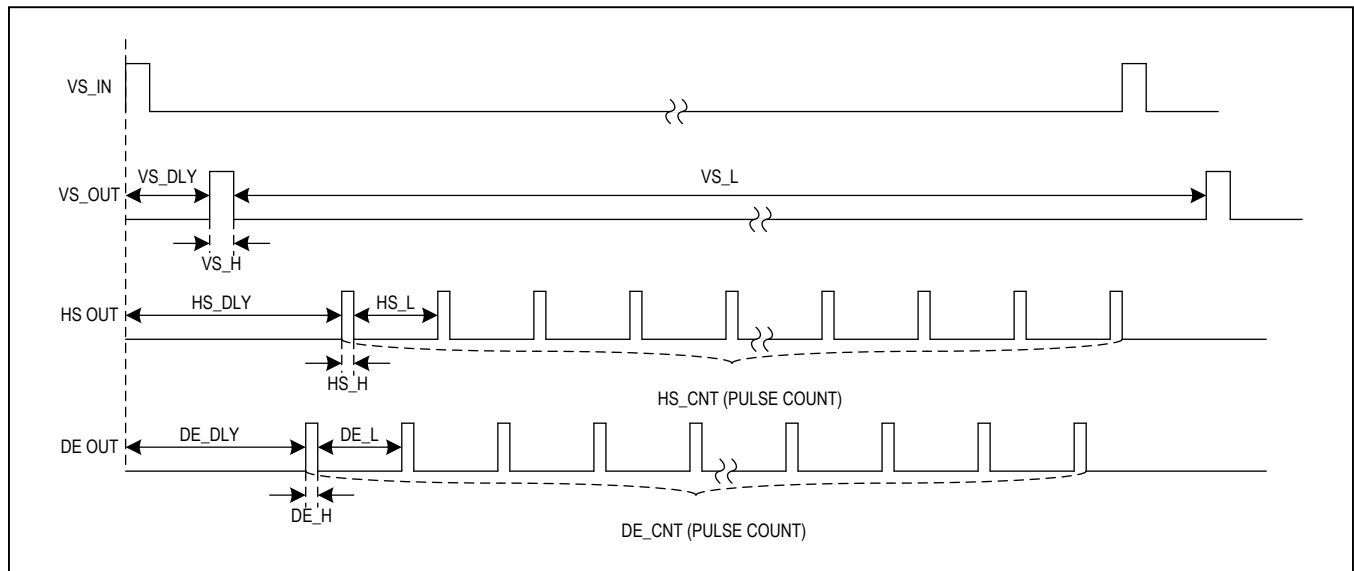

Figure 18. Sync-Signal Format For Video-Timing Generation

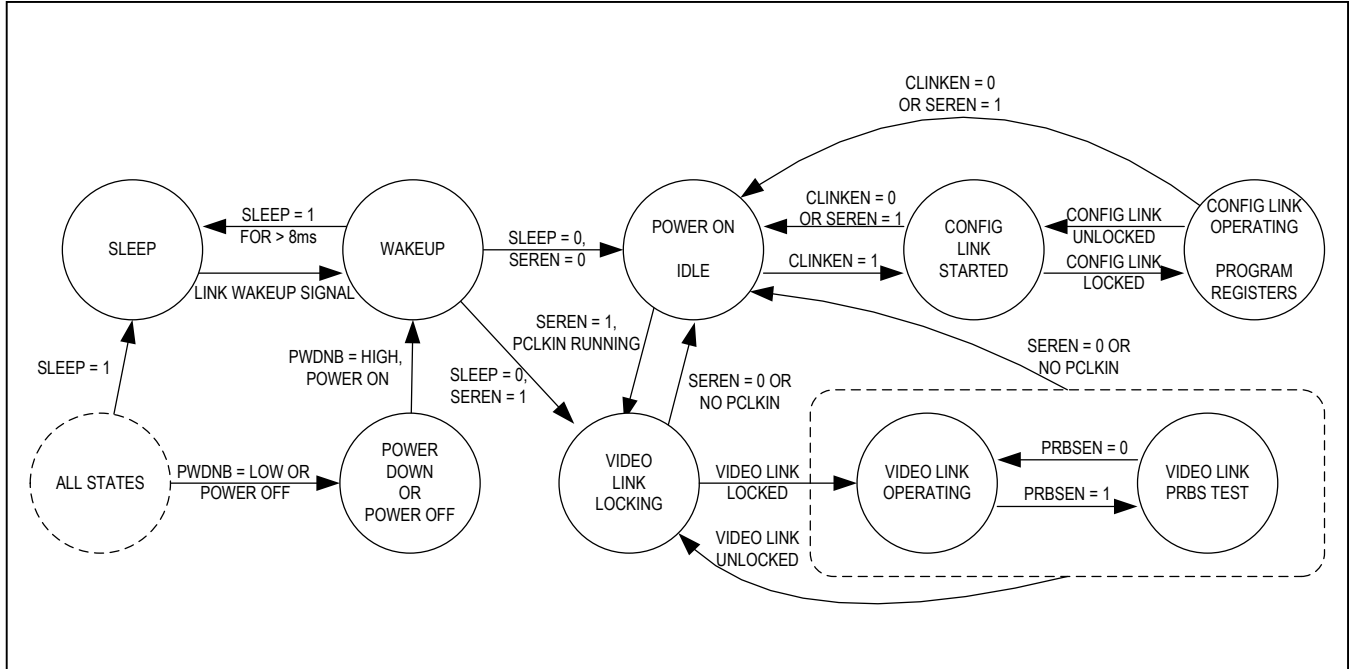

Figure 19. State Diagram

**Shutdown/Sleep Modes**

Several sleep and shutdown modes are available when full operation is not needed.

**Configuration Link**

When the high-speed video link is not needed, or unavailable, a configuration link can be used in its place. In configuration link mode, the parallel digital input/output is disabled, the LOCK pin remains low, and the serial link internally generates its own clock to allow full operation of the control channel (UART/I2C and GPIO).

**Serialization Disable**

When the serial link is not needed, such as when downstream devices are powered off, the user can disable

serialization. In this mode, all forward communication is shut down. The user can reenale serialization either locally, or through the reverse channel.

**Sleep Mode**

To reduce power consumption further, the devices can be put into sleep mode. In this mode, all registers keep their programmed values, and all functions in the device are powered down except for the wake-up detectors on the local control interface, and the serial link. Any activity seen by the wake-up detectors temporarily turns on the control-channel interface. During this time, a microcontroller can command the device to exit sleep mode. See the [Shutdown/Sleep Modes](#) section.

**Power-Down Mode**

The lowest power consumption mode is power-down mode. In this mode, all functions are powered down, and all register values are lost.

**Link Startup Procedure**

Table 2 lists the startup procedure for image-sensing applications. The control channel is available after the video link or the configuration link is established. If the deserializer powers up after the serializer, the control channel becomes unavailable until 2ms after power-up.

**Table 2. Link-Startup Procedure**

NO.	μC	SERIALIZER	DESERIALIZER
—	μC Connected to Deserializer	Set Configuration Inputs	Set Configuration Inputs
1	Powers up (wait $t_{PU}$ ).	Powers up and loads default settings. Establishes video link when valid PCLK is available.	Powers up and loads default settings. Locks to video link signal if available.
1a	If no PCLK, programs CLINKEN, SEREN, and/or AUTOCLINK bits. Wait 5ms after each command.	Establishes configuration link.	Locks to configuration link if available.
1b	If not locked, sets any additional configuration bits that are mismatched between the serializer and deserializer (e.g., BWS, CX/TP). Wait 5ms for lock after each command.	Configuration changed. Reestablishes configuration/video link if needed.	Configuration changed. Locks to configuration/video link.
2	Sets register 0x07 configuration bits in the serializer (DBL, BWS, HIBW, EDC, etc.). Wait 2ms.	Configuration changed. Reestablishes configuration/video link if needed.	Loss-of-lock may occur.
3	Sets register 0x07 configuration bits in the deserializer (DBL, BWS, HIBW, EDC, etc.). Wait 5ms for lock to reestablish.	—	Configuration changed. Locks to configuration/video link.
4	Writes rest of serializer/deserializer configuration bits.	Configuration changed.	Configuration changed.
5	Writes camera/peripheral configuration bits.	Forwards commands from μC to serializer.	Forwards commands to camera/peripherals.
5a	If in configuration link, when PCLK is available, set SEREN = 1. Wait 5ms for lock.	Enables video link.	Locks to video link.



## Register Map

## GMSL Register Map

OFFSET	NAME	MSB							LSB
0x00	seraddr[7:0]	SERADDR[6:0]							CFG-BLOCK
0x01	desaddr[7:0]	DESADDR[6:0]							RSVD
0x02	ss[7:0]	SS[2:0]			RSVD	PRNG[1:0]		SRNG[1:0]	
0x03	sdiv[7:0]	AUTOFM[1:0]			SDIV[5:0]				
0x04	main_control[7:0]	SEREN	CLINKEN	PRBSEN	SLEEP	INTTYPE[1:0]		REVCCEN	FWDCEN
0x05	prbs_len[7:0]	I2C-METHOD	RSVD	PRBS_LEN[1:0]		RSVD	RSVD	RSVD	RSVD
0x06	cmlvl_preemp[7:0]	CMLVL[3:0]				PREEMP[3:0]			
0x07	config[7:0]	DBL	HIBW	BWS	ES	RSVD	HVEN	RSVD	PXL_CRC
0x08	rsvd_8[7:0]	RSVD	RSVD	RSVD	RSVD	RSVD	RSVD	RSVD	RSVD
0x09	i2c_source A[7:0]	I2C_SRC_A[6:0]							RSVD
0x0A	i2c_dest A[7:0]	I2C_DST_A[6:0]							RSVD
0x0B	i2c_source B[7:0]	I2C_SRC_B[6:0]							RSVD
0x0C	i2c_dest B[7:0]	I2C_DST_B[6:0]							RSVD
0x0D	i2c_config[7:0]	I2C_LOC_ACK	I2C_SLV_SH[1:0]		I2C_MST_BT[2:0]			I2C_SLV_TO[1:0]	
0x0E	gpio_en[7:0]	RSVD	RSVD	GPIO_EN_5	GPIO_EN_4	GPIO_EN_3	GPIO_EN_2	GPIO_EN_1	RSVD
0x0F	gpio_out[7:0]	EN_SET_GPO	RSVD	GPIO_OUT_5	GPIO_OUT_4	GPIO_OUT_3	GPIO_OUT_2	GPIO_OUT_1	SET_GPO
0x10	gpio_in[7:0]	RSVD	RSVD	GPIO_IN_5	GPIO_IN_4	GPIO_IN_3	GPIO_IN_2	GPIO_IN_1	GPO_L
0x11	errg[7:0]	ERRG_RATE[1:0]		ERRG_TYPE[1:0]		ERRG_CNT[1:0]		ERRG_PER	ERRG_EN
0x12	rsvd_12[7:0]	RSVD	RSVD	RSVD	RSVD[4:0]				
0x13	pd[7:0]	SOFT_PD	RSVD	RSVD	RSVD	RSVD	RSVD	RSVD[1:0]	
0x14	pktcc_lock[7:0]	RSVD[1:0]		RSVD	RSVD	RSVD	RSVD	CC_WBLOCK	REM_CCLOCK
0x15	input_status[7:0]	CX_TP	RSVD	LCCEN	RSVD	RSVD	RSVD	OUT-PUTEN	PCLKDET
0x16	max_rt_err[7:0]	RSVD	MAX_RT_ERR	RSVD[5:0]					
0x17	rsvd_17[7:0]	RSVD[7:0]							
0x18	crc 0[7:0]	CRC_VALUE_0[7:0]							
0x19	crc 1[7:0]	CRC_VALUE_1[7:0]							
0x1A	crc 2[7:0]	CRC_VALUE_2[7:0]							
0x1B	crc 3[7:0]	CRC_VALUE_3[7:0]							
0x1C	cc_crc_errcnt[7:0]	CC_CRC_ERRCNT[7:0]							
0x1D	rsvd_1d[7:0]	RSVD[7:0]							

## GMSL Register Map (continued)

OFFSET	NAME	MSB					LSB
0x1E	id[7:0]	ID[7:0]					
0x1F	revision[7:0]	RSVD	RSVD	RSVD	HDCPCAP	REVISION[3:0]	
0x20	crossbar 0[7:0]	RSVD	FORCE_MUX_0	INVERT_MUX_0	CROSSBAR_0[4:0]		
0x21	crossbar 1[7:0]	RSVD	FORCE_MUX_1	INVERT_MUX_1	CROSSBAR_1[4:0]		
0x22	crossbar 2[7:0]	RSVD	FORCE_MUX_2	INVERT_MUX_2	CROSSBAR_2[4:0]		
0x23	crossbar 3[7:0]	RSVD	FORCE_MUX_3	INVERT_MUX_3	CROSSBAR_3[4:0]		
0x24	crossbar 4[7:0]	RSVD	FORCE_MUX_4	INVERT_MUX_4	CROSSBAR_4[4:0]		
0x25	crossbar 5[7:0]	RSVD	FORCE_MUX_5	INVERT_MUX_5	CROSSBAR_5[4:0]		
0x26	crossbar 6[7:0]	RSVD	FORCE_MUX_6	INVERT_MUX_6	CROSSBAR_6[4:0]		
0x27	crossbar 7[7:0]	RSVD	FORCE_MUX_7	INVERT_MUX_7	CROSSBAR_7[4:0]		
0x28	crossbar 8[7:0]	RSVD	FORCE_MUX_8	INVERT_MUX_8	CROSSBAR_8[4:0]		
0x29	crossbar 9[7:0]	RSVD	FORCE_MUX_9	INVERT_MUX_9	CROSSBAR_9[4:0]		
0x2A	crossbar 10[7:0]	RSVD	FORCE_MUX_10	INVERT_MUX_10	CROSSBAR_10[4:0]		
0x2B	crossbar 11[7:0]	RSVD	FORCE_MUX_11	INVERT_MUX_11	CROSSBAR_11[4:0]		
0x2C	crossbar 12[7:0]	RSVD	FORCE_MUX_12	INVERT_MUX_12	CROSSBAR_12[4:0]		
0x2D	crossbar 13[7:0]	RSVD	FORCE_MUX_13	INVERT_MUX_13	CROSSBAR_13[4:0]		
0x2E	crossbar 14[7:0]	RSVD	FORCE_MUX_14	INVERT_MUX_14	CROSSBAR_14[4:0]		
0x2F	crossbar 15[7:0]	RSVD	FORCE_MUX_15	INVERT_MUX_15	CROSSBAR_15[4:0]		
0x30	crossbar 16[7:0]	RSVD	FORCE_MUX_16	INVERT_MUX_16	CROSSBAR_16[4:0]		
0x31	crossbar 17[7:0]	RSVD	FORCE_MUX_17	INVERT_MUX_17	CROSSBAR_17[4:0]		
0x32	crossbar 18[7:0]	RSVD	FORCE_MUX_18	INVERT_MUX_18	CROSSBAR_18[4:0]		
0x33	crossbar 19[7:0]	RSVD	FORCE_MUX_19	INVERT_MUX_19	CROSSBAR_19[4:0]		
0x34	crossbar 20[7:0]	RSVD	FORCE_MUX_20	INVERT_MUX_20	CROSSBAR_20[4:0]		

**GMSL Register Map (continued)**

OFFSET	NAME	MSB							LSB
0x35	crossbar 21[7:0]	RSVD	FORCE_MUX_21	INVERT_MUX_21	CROSSBAR_21[4:0]				
0x36	crossbar 22[7:0]	RSVD	FORCE_MUX_22	INVERT_MUX_22	CROSSBAR_22[4:0]				
0x37	crossbar 23[7:0]	RSVD	FORCE_MUX_23	INVERT_MUX_23	CROSSBAR_23[4:0]				
0x38	crossbar 24[7:0]	RSVD	FORCE_MUX_24	INVERT_MUX_24	CROSSBAR_24[4:0]				
0x39	crossbar 25[7:0]	RSVD	FORCE_MUX_25	INVERT_MUX_25	CROSSBAR_25[4:0]				
0x3A	crossbar 26[7:0]	RSVD	FORCE_MUX_26	INVERT_MUX_26	CROSSBAR_26[4:0]				
0x3B	crossbar 27[7:0]	RSVD	FORCE_MUX_27	INVERT_MUX_27	CROSSBAR_27[4:0]				
0x3C	crossbar 28[7:0]	RSVD	FORCE_MUX_28	INVERT_MUX_28	CROSSBAR_28[4:0]				
0x3D	crossbar 29[7:0]	RSVD	FORCE_MUX_29	INVERT_MUX_29	CROSSBAR_29[4:0]				
0x3E	crossbar 30[7:0]	RSVD	FORCE_MUX_30	INVERT_MUX_30	CROSSBAR_30[4:0]				
0x3F	crossbar_hs[7:0]	RSVD	FORCE_MUX_HS	INVERT_MUX_HS	CROSSBARHS[4:0]				
0x40	crossbar_vs[7:0]	RSVD	FORCE_MUX_VS	INVERT_MUX_VS	CROSSBARVS[4:0]				
0x41	crossbar_de[7:0]	RSVD	FORCE_MUX_DE	INVERT_MUX_DE	CROSSBARDE[4:0]				
0x42	link_config[7:0]	LINE_CRC_LOC[1:0]		LINE_CRC_EN	MAX_RT_EN	RSVD	GPI_COMP_EN	GPI_RT_EN	GPO_EN
0x43	sync_gen_config[7:0]	RSVD	RSVD	GEN_VS	GEN_HS	GEN_DE	VS_TRIG	VTG_MODE[1:0]	
0x44	vs_dly 2[7:0]	VS_DLY[7:0]							
0x45	vs_dly 1[7:0]	VS_DLY[7:0]							
0x46	vs_dly 0[7:0]	VS_DLY[7:0]							
0x47	vs_h 2[7:0]	VS_H[7:0]							
0x48	vs_h 1[7:0]	VS_H[7:0]							
0x49	vs_h 0[7:0]	VS_H[7:0]							
0x4A	vs_l 2[7:0]	VS_L[7:0]							
0x4B	vs_l 1[7:0]	VS_L[7:0]							
0x4C	vs_l 0[7:0]	VS_L[7:0]							
0x4D	cxtp[7:0]	RSVD	CXTP	RSVD	RSVD	VSYNC_INV	HSYNC_INV	DE_INV	RSVD
0x4E	hs_dly 2[7:0]	HS_DLY[7:0]							

## GMSL Register Map (continued)

OFFSET	NAME	MSB							LSB
0x4F	hs_dly 1[7:0]	HS_DLY[7:0]							
0x50	hs_dly 0[7:0]	HS_DLY[7:0]							
0x51	rsvd[7:0]	RSVD	RSVD	RSVD	RSVD	RSVD	RSVD	RSVD	RSVD
0x52	rsvd[7:0]	RSVD	RSVD	RSVD	RSVD	RSVD	RSVD	RSVD	RSVD
0x53	rsvd[7:0]	RSVD	RSVD	RSVD	RSVD	RSVD	RSVD	RSVD	RSVD
0x54	hs_h 1[7:0]	HS_H[7:0]							
0x55	hs_h 0[7:0]	HS_H[7:0]							
0x56	hs_l 1[7:0]	HS_L[7:0]							
0x57	hs_l 0[7:0]	HS_L[7:0]							
0x58	hs_cnt 1[7:0]	HS_CNT[7:0]							
0x59	hs_cnt 0[7:0]	HS_CNT[7:0]							
0x5A	de_dly 2[7:0]	DE_DLY[7:0]							
0x5B	de_dly 1[7:0]	DE_DLY[7:0]							
0x5C	de_dly 0[7:0]	DE_DLY[7:0]							
0x5D	rsvd[7:0]	RSVD	RSVD	RSVD	RSVD	RSVD	RSVD	RSVD	RSVD
0x5E	rsvd[7:0]	RSVD	RSVD	RSVD	RSVD	RSVD	RSVD	RSVD	RSVD
0x5F	rsvd[7:0]	RSVD	RSVD	RSVD	RSVD	RSVD	RSVD	RSVD	RSVD
0x60	de_h 1[7:0]	DE_H[7:0]							
0x61	de_h 0[7:0]	DE_H[7:0]							
0x62	de_l 1[7:0]	DE_L[7:0]							
0x63	de_l 0[7:0]	DE_L[7:0]							
0x64	de_cnt 1[7:0]	DE_CNT_1[7:0]							
0x65	de_cnt 0[7:0]	DE_CNT_0[7:0]							
0x66	prbs_type[7:0]	RSVD[1:0]		PRBS_TYPE	REV_FAST	DE_EN	DIS_WAKE	RSVD	CXSEL
0x67	dbl_align_to[7:0]	RSVD[1:0]		AUTO_CLINK	RSVD	RSVD	DBL_ALIGN_TO[2:0]		
0x68	cc_crc_length[7:0]	RSVD	RSVD[2:0]			RSVD[1:0]		CC_CRC_LENGTH[1:0]	
0x69	hi_lo[7:0]	RSVD	EN_HI_LO	INVERT_HI_LO	CROSSBAR_HI_LO[4:0]				
0x96	rsvd_96[7:0]	RSVD	RSVD	RSVD	RSVD	RSVD	RSVD	RSVD[1:0]	
0x97	rsvd_97[7:0]	RSVD	RSVD	RSVD	RSVD	RSVD	RSVD[2:0]		
0x98	rsvd_98[7:0]	RSVD[1:0]		RSVD[2:0]			RSVD[2:0]		
0x99	rsvd_99[7:0]	RSVD	RSVD	RSVD	RSVD	RSVD	RSVD	RSVD[1:0]	
0x9A	pktcc_en[7:0]	RSVD[1:0]		RSVD[1:0]		PKTCC_EN	RSVD[1:0]		RSVD

**GMSL Register Map (continued)**

OFFSET	NAME	MSB							LSB
0xC8	rsvd_c8[7:0]	RSVD	RSVD	RSVD	RSVD	RSVD	RSVD	RSVD	RSVD
0xC9	rsvd_c9[7:0]	RSVD[7:0]							
0xFC	rsvd_fc[7:0]	RSVD	RSVD	RSVD	RSVD	RSVD	RSVD	RSVD	RSVD
0xFD	rsvd_fd[7:0]	RSVD[7:0]							
0xFE	rsvd_fe[7:0]	RSVD[3:0]				RSVD[3:0]			
0xFF	rsvd_ff[7:0]	RSVD	RSVD	RSVD	RSVD	RSVD[3:0]			

**seraddr (0x00)**

BIT	7	6	5	4	3	2	1	0
Field	SERADDR[6:0]							CFGBLOCK
Reset	1000000							0b
Access Type	Write, Read							Write, Read

BITFIELD	BITS	DESCRIPTION	DECODE
SERADDR	7:1	<b>Serializer Address:</b> Serializer device address	0000000: Write/read device address is 0x00/0x01 0000001: Write/read device address is 0x02/0x03 1111111: Write/read device address is 0xFE/0xFF
CFG-BLOCK	0	<b>Configuration Block:</b> Set to 1 to make all registers read-only. Set PWDNB low, or a power-on reset to clear this bit.	0: Make all registers read/write 1: Make all registers read-only

**desaddr (0x01)**

BIT	7	6	5	4	3	2	1	0
Field	DESADDR[6:0]							RSVD
Reset	1001000b							0b
Access Type	Write, Read							Write, Read

BITFIELD	BITS	DESCRIPTION	DECODE
DESADDR	7:1	<b>Deserializer Address:</b> Deserializer device address	0000000: Write/read device address is 0x00/0x01 0000001: Write/read device address is 0x02/0x03 1111111: Write/read device address is 0xFE/0xFF
RSVD	0	<b>Reserved:</b> Do not change from default value	0: Reserved

**ss (0x02)**

BIT	7	6	5	4	3	2	1	0
<b>Field</b>	SS[2:0]			RSVD	PRNG[1:0]		SRNG[1:0]	
<b>Reset</b>	000b			1b	11b		11b	
<b>Access Type</b>	Write, Read			Write, Read	Write, Read		Write, Read	

BITFIELD	BITS	DESCRIPTION	DECODE
SS	7:5	<b>Spread Spectrum:</b> Spread-spectrum setting	000: Spread is off 001: 0.5% Spread setting 010: 1.5% Spread setting 011: 2% Spread setting 100: Spread is off 101: 1% Spread setting 110: 3% Spread setting 111: 4% Spread setting
RSVD	4	<b>Reserved:</b> Do not change from default value	1: Reserved
PRNG	3:2	<b>Pixel Clock Range:</b> Pixel clock-range selection Stated ranges depend on DBL = setting	00: Select 12.5MHz to 25MHz (DBL = 0) or 25MHz to 50MHz (DBL = 1) pixel clock range 01: Select 25MHz to 58MHz (DBL = 0) or 50MHz to 116MHz (DBL = 1) pixel clock range 10: Automatically detect pixel clock range 11: Automatically detect pixel clock range.
SRNG	1:0	<b>Serial-Data Rate Range</b>	00: 0.5Gbps to 1Gbps serial-data range 01: 1Gbps to 1.74Gbps serial-data range 10: Automatically detect serial-data range 11: Automatically detect serial-data range

**sdiv (0x03)**

BIT	7	6	5	4	3	2	1	0
<b>Field</b>	AUTOFM[1:0]			SDIV[5:0]				
<b>Reset</b>	00b			000000b				
<b>Access Type</b>	Write, Read			Write, Read				

BITFIELD	BITS	DESCRIPTION	DECODE
AUTOFM	7:6	<b>Automatic Frequency Modulation:</b> Modulation-rate calibration interval	00: Calibration occurs once 01: Calibration occurs every 2ms 10: Calibration occurs every 16ms 11: Calibration occurs every 256ms
SDIV	5:0	<b>Sawtooth Divider:</b> Sawtooth divider value 0x00 sets the sawtooth divider to autocalibrate mode	000000: Sawtooth divider automatically calibrates the divider value 000001: Sawtooth divider set to 1 111111: Sawtooth divider set to 63

**main\_control (0x04)**

BIT	7	6	5	4	3	2	1	0
Field	SEREN	CLINKEN	PRBSEN	SLEEP	INTTYPE[1:0]		REVCCEN	FWDCEN
Reset	1b	0b	0b	0b	1b		1b	1b
Access Type	Write, Read	Write, Read	Write, Read	Write, Read	Write, Read		Write, Read	Write, Read

BITFIELD	BITS	DESCRIPTION	DECODE
SEREN	7	<b>Serialization Enable:</b> Requires a valid PCLK for serialization	0: Disable serialization 1: Enable serialization
CLINKEN	6	<b>Configuration Link Enable:</b> Configuration link enabled only when the video link is not enabled (SEREN = 1)	0: Disable configuration link 1: Enable configuration link
PRBSEN	5	<b>PRBS Test Enable:</b> See the PRBS test section for more details	0: Disable PRBS test 1: Enable PRBS test
SLEEP	4	<b>Sleep Mode Enable:</b> Activates sleep mode (see the <a href="#">Shutdown/Sleep Modes</a> section for more information)	0: Disable sleep mode 1: Enable sleep mode
INTTYPE	3:2	<b>UART/I<sup>2</sup>C Interface Type:</b> Local control-channel interface when in UART/UART or UART/I <sup>2</sup> C mode (I2CSEL = 0)	00: Device performs UART-to-I <sup>2</sup> C conversion when functioning as the remote device 01: Device outputs UART packets when functioning as the remote device 10: Tx/Rx input/outputs disabled when functioning as the remote device 11: Tx/Rx input/outputs disabled when functioning as the remote device
REVCCEN	1	<b>Reverse Control-Channel Enable:</b> Enable reverse control-channel receiver (data from deserializer)	0: Disable reverse control-channel receiver 1: Enable reverse control-channel receiver
FWDCEN	0	<b>Forward Control Channel Enable:</b> Enable forward control channel receiver (data to deserializer)	0: Disable forward control channel transmitter 1: Enable forward control channel transmitter

**prbs\_len (0x05)**

BIT	7	6	5	4	3	2	1	0
<b>Field</b>	I2C-METHOD	RSVD	PRBS_LEN[1:0]		RSVD	RSVD	RSVD	RSVD
<b>Reset</b>	0b	0b	00b		0b	0b	0b	0b
<b>Access Type</b>	Write, Read	Write, Read	Write, Read		Write, Read	Write, Read	Write, Read	Write, Read

BITFIELD	BITS	DESCRIPTION	DECODE
I2CMETHOD	7	<b>UART-to-I<sup>2</sup>C Method:</b> When set, skip the sending of the register address when converting UART to I <sup>2</sup> C (I2CSEL = 0).	0: Do not skip the sending of the register address 1: Skip the sending of the register address
RSVD	6	<b>Reserved:</b> Do not change from default value.	0: Reserved
PRBS_LEN	5:4	<b>PRBS Length:</b> PRBS test pattern length	00: Continuous bit pattern (infinite length) 01: 9.8Mbit length 10: 167.1Mbit length 11: 1341.5Mbit length
RSVD	3	<b>Reserved:</b> Do not change from default value	0: Reserved
RSVD	2	<b>Reserved:</b> Do not change from default value.	0: Reserved
RSVD	1	<b>Reserved:</b> Do not change from default value.	0: Reserved
RSVD	0	<b>Reserved:</b> Do not change from default value.	0: Reserved



**cmlvl\_preemp (0x06)**

BIT	7	6	5	4	3	2	1	0
Field	CMLLVL[3:0]				PREEMP[3:0]			
Reset	10X0b				0000b			
Access Type	Write, Read				Write, Read			

BITFIELD	BITS	DESCRIPTION	DECODE
CMLLVL	7:4	<b>CML Level:</b> Output CML signal level = (register value) x 50mV Default level depends on cable type (COTP)	0000: Do not use 0001: Do not use 0010: 100mV output 0011: 150mV output 0100: 200mV output 0101: 250mV output 0110: 300mV output 0111: 350mV output 1000: 400mV output (STP default) 1001: 450mV output 1010: 500mV output (coax default) 1011: Do not use 1100: Do not use 1101: Do not use 111X: Do not use
PREEMP	3:0	<b>Preemphasis Level:</b> Preemphasis setting Negative preemphasis levels denote deemphasis	0000: Preemphasis off 0001: 1.2dB deemphasis 0010: 2.5dB deemphasis 0011: 4.1dB deemphasis 0100: 6.0dB deemphasis 0101: Do not use 011X: Do not use 1000: 1.1dB preemphasis 1001: 2.2dB preemphasis 1010: 3.3dB preemphasis 1011: 4.4dB preemphasis 1100: 6.0dB preemphasis 1101: 8.0dB preemphasis 1110: 10.5dB preemphasis 1111: 14.0dB preemphasis

**config (0x07)**

BIT	7	6	5	4	3	2	1	0
Field	DBL	HIBW	BWS	ES	RSVD	HVEN	RSVD	PXL_CRC
Reset	0b	0b	Xb	Xb	0b	0b	0b	0b
Access Type	Write, Read	Write, Read	Write, Read	Write, Read	Write, Read	Write, Read	Write, Read	Write, Read

BITFIELD	BITS	DESCRIPTION	DECODE
DBL	7	<b>Double-Input Mode Enable:</b> Set high to enable double-input mode. Default setting is determined by LCCEN and TX/SCL/DBL pin setting at power-up.	0: Single-input mode 1: Double-input mode
HIBW	6	<b>High-Bandwidth Mode Enable:</b> High-bandwidth mode select (effective only when BWS = 0)	0: Use 24-bit mode when BWS = 0 1: Use high-bandwidth mode when BWS = 0
BWS	5	<b>Bus-Width Select:</b> Default value is determined by LCCEN and GPIO1/BWS pin setting at power-up.	0: 24-bit and high-bandwidth mode 1: 32-bit mode
ES	4	<b>Edge Select:</b> Default value is determined by CONF[1:0] pins at power-up	0: Parallel data clocked in on rising edge 1: Parallel data clocked in on falling edge
RSVD	3	<b>Reserved:</b> Do not change from default value.	0: Reserved
HVEN	2	<b>HSYNC/VSYNC Encoding Enable:</b> Default value is determined by LCCEN and MS/HVEN pin setting at powerup	0: Disable HS/VS encoding 1: Enable HS/VS encoding
RSVD	1	<b>Reserved:</b> Do not change from default value.	0: Reserved
PXL_CRC	0	<b>Pixel CRC Type:</b> pixel error-detection type Effective only when HIBW = 0	0: Serial data uses 1-bit parity 1: Serial data uses 6-bit CRC

**rsvd\_8 (0x08)**

BIT	7	6	5	4	3	2	1	0
Field	RSVD	RSVD	RSVD	RSVD	RSVD	RSVD	RSVD	RSVD
Reset	0b	0b	0b	0b	0b	0b	0b	0b
Access Type	Write, Read	Write, Read	Write, Read	Write, Read	Write, Read	Write, Read	Write, Read	Write, Read

BITFIELD	BITS	DESCRIPTION	DECODE
RSVD	7	<b>Reserved:</b> Do not change from default value.	0: Reserved
RSVD	6	<b>Reserved:</b> Do not change from default value.	0: Reserved
RSVD	5	<b>Reserved:</b> Do not change from default value.	0: Reserved
RSVD	4	<b>Reserved:</b> Do not change from default value.	0: Reserved
RSVD	3	<b>Reserved:</b> Do not change from default value.	0: Reserved
RSVD	2	<b>Reserved:</b> Do not change from default value.	0: Reserved
RSVD	1	<b>Reserved:</b> Do not change from default value.	0: Reserved
RSVD	0	<b>Reserved:</b> Do not change from default value.	0: Reserved

**i2c\_source (0x09, 0x0B)**

BIT	7	6	5	4	3	2	1	0
Field	I2C_SRC[6:0]							RSVD
Reset	0000000b							0b
Access Type	Write, Read							Write, Read

BITFIELD	BITS	DESCRIPTION	DECODE
I2C_SRC	7:1	<b>I2C Source:</b> I2C address translator source	0000000: Write/read device address is 0x00/0x01 0000001: Write/read device address is 0x02/0x03 1111111: Write/read device address is 0xFE/0xFF
RSVD	0	<b>Reserved:</b> Do not change from default value.	0: Reserved

**i2c\_dest (0x0A, 0x0C)**

BIT	7	6	5	4	3	2	1	0
Field	I2C_DST[6:0]							RSVD
Reset	0000000b							0b
Access Type	Write, Read							Write, Read

BITFIELD	BITS	DESCRIPTION	DECODE
I2C_DST	7:1	<b>I2C Destination:</b> I2C address translator destination	0000000: Write/read device address is 0x00/0x01 0000001: Write/read device address is 0x02/0x03 1111111: Write/read device address is 0xFE/0xFF
RSVD	0	<b>Reserved:</b> Do not change from default value.	0: Reserved

**i2c\_config (0x0D)**

BIT	7	6	5	4	3	2	1	0
<b>Field</b>	I2C_LOC_ACK	I2C_SLV_SH[1:0]		I2C_MST_BT[2:0]			I2C_SLV_TO[1:0]	
<b>Reset</b>	1b	01b		101b			10b	
<b>Access Type</b>	Write, Read	Write, Read		Write, Read			Write, Read	

BITFIELD	BITS	DESCRIPTION	DECODE
I2C_LOC_ACK	7	<b>I<sup>2</sup>C Local Acknowledge:</b> I <sup>2</sup> C-to-I <sup>2</sup> C slave generates local acknowledge when forward channel is not available	0: Do not send local autoacknowledge when control channel is absent 1: Send local autoacknowledge when control channel is absent
I2C_SLV_SH	6:5	<b>I<sup>2</sup>C Slave Setup/Hold Time:</b> I <sup>2</sup> C-to-I <sup>2</sup> C slave setup and hold-time setting (setup, hold) (typ)	00: (352ns, 117ns) setup/hold time 01: (469ns, 234ns) setup/hold time 10: (938ns, 352ns) setup/hold time 11: (1406ns, 469ns) setup/hold time
I2C_MST_BT	4:2	<b>I<sup>2</sup>C Master Bit Rate:</b> I <sup>2</sup> C-to-I <sup>2</sup> C master bit-rate setting (min, typ, max)	000: (6.61, 8.47, 9.92) kbps 001: (22.1, 28.3, 33.2) kbps 010: (66.1, 84.7, 99.2) kbps 011: (82, 105, 123) kbps 100: (136, 173, 203) kbps 101: (265, 339, 397) kbps 110: (417, 533, 625) kbps 111: (654, 837, 980) kbps
I2C_SLV_TO	1:0	<b>I<sup>2</sup>C Slave Timeout:</b> I <sup>2</sup> C-to-I <sup>2</sup> C slave remote-side timeout setting (typ).	00: 64μs slave timeout 01: 256μs slave timeout 10: 1024μs slave timeout 11: Slave timeout disabled

**gpio\_en (0x0E)**

BIT	7	6	5	4	3	2	1	0
Field	RSVD	RSVD	GPIO_EN_5	GPIO_EN_4	GPIO_EN_3	GPIO_EN_2	GPIO_EN_1	RSVD
Reset	0b	0b	0b	0b	0b	0b	1b	0b
Access Type	Write, Read	Write, Read	Write, Read	Write, Read	Write, Read	Write, Read	Write, Read	Write, Read

BITFIELD	BITS	DESCRIPTION	DECODE
RSVD	7	<b>Reserved:</b> Do not change from default value.	0: Reserved
RSVD	6	<b>Reserved:</b> Do not change from default value.	0: Reserved
GPIO_EN_5	5	<b>GPIO Enable:</b> Disabled by default	0: Pin functions as a parallel input 1: Pin functions as a GPIO
GPIO_EN_4	4	<b>GPIO Enable:</b> Disabled by default.	0: Pin functions as a parallel input 1: Pin functions as a GPIO
GPIO_EN_3	3	<b>GPIO Enable:</b> Disabled by default.	0: Pin functions as a parallel input 1: Pin functions as a GPIO
GPIO_EN_2	2	<b>GPIO Enable:</b> Disabled by default	0: Pin functions as a parallel input 1: Pin functions as a GPIO
GPIO_EN_1	1	<b>GPIO Enable:</b> Disabled by default	0: Pin functions as parallel input 1: Pin functions as GPIO
RSVD	0	<b>Reserved:</b> Do not change from default value	0: Reserved

**gpio\_out (0x0F)**

BIT	7	6	5	4	3	2	1	0
Field	EN_SET_GPO	RSVD	GPIO_OUT_5	GPIO_OUT_4	GPIO_OUT_3	GPIO_OUT_2	GPIO_OUT_1	SET_GPO
Reset	1b	0b	1b	1b	1b	1b	1b	0b
Access Type	Write, Read	Write, Read	Write, Read	Write, Read	Write, Read	Write, Read	Write, Read	Write, Read

BITFIELD	BITS	DESCRIPTION	DECODE
EN_SET_GPO	7	<b>Enable Set GPO:</b> Set to 1 to enable setting of GPO from SET_GPO	0: Disable setting of GPO through SET_GPO 1: Enable setting of GPO through SET_GPO
RSVD	6	<b>Reserved:</b> Do not change from default value	0: Reserved
GPIO_OUT_5	5	<b>GPIO Output Level:</b> Pull down GPIO when 0	0: Set GPIO output level low 1: Set GPIO output level high
GPIO_OUT_4	4	<b>GPIO Output Level:</b> Pull down GPIO when 0	0: Set GPIO output level lo 1: Set GPIO output level high
GPIO_OUT_3	3	<b>GPIO Output Level:</b> Pull down GPIO when 0	0: Set GPIO output leve 1: Set GPIO output level high
GPIO_OUT_2	2	<b>GPIO Output Level:</b> Pull down GPIO when 0	0: Set GPIO output level low 1: Set GPIO output level high
GPIO_OUT_1	1	<b>GPIO Output Level:</b> Pull down GPIO when 0	0: Set GPIO output level low 1: Set GPIO output level high
SET_GPO	0	<b>Set GPO Level:</b> Set GPO output high or low (when EN_SET_GPO = 1)	0: Set GPO output low 1: Set GPO output high

**gpio\_in (0x10)**

BIT	7	6	5	4	3	2	1	0
Field	RSVD	RSVD	GPIO_IN_5	GPIO_IN_4	GPIO_IN_3	GPIO_IN_2	GPIO_IN_1	GPO_L
Reset	0b	0b	Xb	Xb	Xb	Xb	Xb	Xb
Access Type	Read Only	Read Only	Read Only	Read Only	Read Only	Read Only	Read Only	Read Only

BITFIELD	BITS	DESCRIPTION	DECODE
RSVD	7	<b>Reserved</b>	0: Reserved
RSVD	6	<b>Reserved</b>	0: Reserved
GPIO_IN_5	5	<b>GPIO Input Level:</b> Input pin level of GPIO	0: GPIO input is low 1: GPIO input is high
GPIO_IN_4	4	<b>GPIO Input Level:</b> Input pin level of GPIO	0: GPIO input is low 1: GPIO input is high
GPIO_IN_3	3	<b>GPIO Input Level:</b> Input pin level of GPIO	0: GPIO input is low 1: GPIO input is high
GPIO_IN_2	2	<b>GPIO Input Level:</b> Input pin level of GPIO	0: GPIO input is low 1: GPIO input is high
GPIO_IN_1	1	<b>GPIO Input Level:</b> Input pin level of GPIO	0: GPIO input is low 1: GPIO input is high
GPO_L	0	<b>GPO Output Level</b>	0: GPI output level is low 1: GPO output level is high

**errg (0x11)**

BIT	7	6	5	4	3	2	1	0
Field	ERRG_RATE[1:0]		ERRG_TYPE[1:0]		ERRG_CNT[1:0]		ERRG_PER	ERRG_EN
Reset	0b		0b		0b		0b	0b
Access Type	Write, Read		Write, Read		Write, Read		Write, Read	Write, Read

BITFIELD	BITS	DESCRIPTION	DECODE
ERRG_RATE	7:6	<b>Error-Generation Rate:</b> Error-generation rate, on average	00: Generate errors every 2560 bits 01: Generate errors every 40,960 bits 10: Generate errors every 655,360 bits 11: Generate errors every 10,485,760 bits
ERRG_TYPE	5:4	<b>Error-Generation Type:</b> Type of generated errors	00: Single-bit errors 01: 2 8b/10b symbols 10: 3 8b/10b symbols 11: 4 8b/10b symbols
ERRG_CNT	3:2	<b>Error-Generation Count:</b> Number of generated errors	00: Generate errors continuously 01: Generate 16 errors 10: Generate 128 errors 11: Generate 1024 errors
ERRG_PER	1	<b>Periodic Error Generation Enable</b>	0: Generator creates errors randomly (based on error rate) 1: Generator creates errors periodically (based on error rate)
ERRG_EN	0	<b>Error Generator Enable</b>	0: Disable error generator 1: Enable error generator

**rsvd\_12 (0x12)**

BIT	7	6	5	4	3	2	1	0
Field	RSVD	RSVD	RSVD	RSVD[4:0]				
Reset	0b	1b	0b	00000b				
Access Type	Write, Read	Write, Read	Write, Read	Write, Read				

BITFIELD	BITS	DESCRIPTION	DECODE
RSVD	7	<b>Reserved:</b> Do not change from default value	0: Reserved
RSVD	6	<b>Reserved:</b> Do not change from default value	1: Reserved
RSVD	5	<b>Reserved:</b> Do not change from default value	0: Reserved
RSVD	4:0	<b>Reserved:</b> Do not change from default value	00000: Reserved

**pd (0x13)**

BIT	7	6	5	4	3	2	1	0
Field	SOFT_PD	RSVD	RSVD	RSVD	RSVD	RSVD	RSVD[1:0]	
Reset	0b	0b	0b	0b	0b	0b	10b	
Access Type	Write 1 to Set, Read	Write, Read	Write, Read	Write, Read	Write, Read	Write, Read	Write, Read	

BITFIELD	BITS	DESCRIPTION	DECODE
SOFT_PD	7	<b>Soft Power Down:</b> Set this bit to 1 to reset the device; this bit is cleared after the device resets	0: Normal operation 1: Reset the device (bit clears itself)
RSVD	6	<b>Reserved:</b> Do not change from default value	0: Reserved
RSVD	5	<b>Reserved:</b> Do not change from default value	0: Reserved
RSVD	4	<b>Reserved:</b> Do not change from default value	0: Reserved
RSVD	3	<b>Reserved:</b> Do not change from default value	0: Reserved
RSVD	2	<b>Reserved:</b> Do not change from default value	0: Reserved
RSVD	1:0	<b>Reserved:</b> Do not change from default value	10: Reserved

**pktcc\_lock (0x14)**

BIT	7	6	5	4	3	2	1	0
Field	RSVD[1:0]		RSVD	RSVD	RSVD	RSVD	CC_WBLOCK	REM_CCLOCK
Reset	XXb		Xb	Xb	Xb	Xb	Xb	Xb
Access Type	Read Only		Read Only	Read Only	Read Clears All	Read Only	Read Only	Read Only

BITFIELD	BITS	DESCRIPTION	DECODE
RSVD	7:6	<b>Reserved:</b> Do not change from default value	XX: Reserved
RSVD	5	<b>Reserved:</b> Do not change from default value	X: Reserved
RSVD	4	<b>Reserved:</b> Do not change from default value	X: Reserved
RSVD	3	<b>Reserved:</b> Do not change from default value	X: Reserved
RSVD	2	<b>Reserved:</b> Do not change from default value	X: Reserved
CC_WBLOCK	1	<b>Control-Channel Word Boundary Locked</b>	0: Control-channel word boundary is not locked 1: Control-channel word boundary is locked
REM_CCLOCK	0	<b>Remote-Side Control Channel Locked</b>	0: Remote side control channel is not locked 1: Remote side control channel is locked



**input\_status (0x15)**

BIT	7	6	5	4	3	2	1	0
Field	CX_TP	RSVD	LCCEN	RSVD	RSVD	RSVD	OUTPUTEN	PCLKDET
Reset	Xb	Xb	Xb	0b	0b	0b	Xb	Xb
Access Type	Read Only	Read Only	Write, Read	Read Only	Read Only	Read Only	Read Only	Read Only

BITFIELD	BITS	DESCRIPTION	DECODE
CX_TP	7	<b>Coax/Twisted Pair level:</b> CX_TP pin level	0: CX/TP input is low 1: CX/TP input is high
RSVD	6	<b>Reserved:</b> Do not change from default value	X: Reserved
LCCEN	5	<b>Detected LCCEN pin level</b>	0: Pin is input low 1: Pin is input high
RSVD	4	<b>Reserved</b>	0: Reserved
RSVD	3	<b>Reserved</b>	0: Reserved
RSVD	2	<b>Reserved</b>	0: Reserved
OUT-PUTEN	1	<b>Output Enabled</b>	0: Output disabled 1: Output enabled
PCLKDET	0	<b>PCLK Detected:</b> Valid PCLK detected	0: No valid PCLK detected 1: Valid PCLK detected

**max\_rt\_err (0x16)**

BIT	7	6	5	4	3	2	1	0
Field	RSVD	MAX_RT_ERR	RSVD[5:0]					
Reset	0b	Xb	XXXXXXb					
Access Type	Read Only	Read Clears All	Read Only					

BITFIELD	BITS	DESCRIPTION	DECODE
RSVD	7	<b>Reserved</b>	0: Reserved
MAX_RT_ERR	6	<b>Maximum Retransmission Error:</b> maximum retransmission error bit Goes high if packet control channel hits maximum retransmission limit. Cleared when read.	0: Device has not reached maximum retransmission limit. 1: Device has reached maximum retransmission limit.
RSVD	5:0	<b>Reserved:</b> Do not change from default value.	XXXXXX: Reserved

**rsvd\_17 (0x17)**

<b>BIT</b>	<b>7</b>	<b>6</b>	<b>5</b>	<b>4</b>	<b>3</b>	<b>2</b>	<b>1</b>	<b>0</b>
<b>Field</b>	RSVD[7:0]							
<b>Reset</b>	XXXXXXXXb							
<b>Access Type</b>	Read Only							

<b>BITFIELD</b>	<b>BITS</b>	<b>DESCRIPTION</b>	<b>DECODE</b>
RSVD	7:0	<b>Reserved:</b> Do not change from default value	XXXXXXXX: Reserved

**crc (0x18 to 0x1B)**

<b>BIT</b>	<b>7</b>	<b>6</b>	<b>5</b>	<b>4</b>	<b>3</b>	<b>2</b>	<b>1</b>	<b>0</b>
<b>Field</b>	CRC_VALUE[7:0]							
<b>Reset</b>	XXXXXXXXb							
<b>Access Type</b>	Read Only							

<b>BITFIELD</b>	<b>BITS</b>	<b>DESCRIPTION</b>	<b>DECODE</b>
CRC_VALUE	7:0	<b>CRC Value:</b> CRC output for latest line CRC_VALUE_3 to CRC_VALUE_0 represents CRC[31:0]	00000000: Value is 0 00000001: Value is 1 11111111: Value is 255

**cc\_crc\_errcnt (0x1C)**

<b>BIT</b>	<b>7</b>	<b>6</b>	<b>5</b>	<b>4</b>	<b>3</b>	<b>2</b>	<b>1</b>	<b>0</b>
<b>Field</b>	CC_CRC_ERRCNT[7:0]							
<b>Reset</b>	XXXXXXXXb							
<b>Access Type</b>	Read Only							

<b>BITFIELD</b>	<b>BITS</b>	<b>DESCRIPTION</b>	<b>DECODE</b>
CC_CRC_ERRCNT	7:0	<b>Control-Channel CRC Error Count:</b> Packet-based control-channel CRC error counter	00000000: Value is 0 00000001: Value is 1 11111111: Value is 255

**rsvd\_1d (0x1D)**

<b>BIT</b>	<b>7</b>	<b>6</b>	<b>5</b>	<b>4</b>	<b>3</b>	<b>2</b>	<b>1</b>	<b>0</b>
<b>Field</b>	RSVD[7:0]							
<b>Reset</b>	XXXXXXXXb							
<b>Access Type</b>	Read Only							

<b>BITFIELD</b>	<b>BITS</b>	<b>DESCRIPTION</b>	<b>DECODE</b>
RSVD	7:0	<b>Reserved:</b> Do not change from default value	XXXXXXXX: Reserved

**id (0x1E)**

BIT	7	6	5	4	3	2	1	0
Field	ID[7:0]							
Reset	XXXXXXXXb							
Access Type	Read Only							

BITFIELD	BITS	DESCRIPTION	DECODE
ID	7:0	<b>Device ID:</b> 8-bit value depends on the GMSL device attached	01000001 Device is a MAX96705

**revision (0x1F)**

BIT	7	6	5	4	3	2	1	0
Field	RSVD	RSVD	RSVD	HDCPCAP	REVISION[3:0]			
Reset	0b	0b	0b	Xb	XXXXb			
Access Type	Read Only	Read Only	Read Only	Read Only	Read Only			

BITFIELD	BITS	DESCRIPTION	DECODE
RSVD	7	<b>Reserved</b>	0: Reserved
RSVD	6	<b>Reserved</b>	0: Reserved
RSVD	5	<b>Reserved</b>	0: Reserved
HDCPCAP	4	<b>HDCP Capability:</b> 1 = HDCP capable	0: Device does not have HDCP 1: Device is HDCP capable
REVISION	3:0	<b>Device Revision</b>	0000: Value is 0 0001: Value is 1 1111: Value is 15

**crossbar (0x20 to 0x3E)**

BIT	7	6	5	4	3	2	1	0
<b>Field</b>	RSVD	FORCE_ MUX	INVERT_ MUX	CROSSBAR[4:0]				
<b>Reset</b>	0b	0b	0b	XXXXXb				
<b>Access Type</b>	Write, Read	Write, Read	Write, Read	Write, Read				

BITFIELD	BITS	DESCRIPTION	DECODE
RSVD	7	<b>Reserved:</b> Do not change from default value	0: Reserved
FORCE_ MUX	6	<b>Force Mux Output</b>	0: Input mapped to mux output 1: Force mux output low
INVERT_ MUX	5	<b>Invert Mux Output</b>	0: Do not invert mux output 1: Invert mux output
CROSS- BAR	4:0	<b>Crossbar Setting</b> Select 1 of 32 input signals. Default values connect Mux N with input N for flow-through routing (i.e., DIN_ mapped to DOUT_).	00000: Mux outputs data from input 0 00001: Mux outputs data from input 1 11111: Mux outputs data from input 31

**crossbar\_hs (0x3F)**

BIT	7	6	5	4	3	2	1	0
<b>Field</b>	RSVD	FORCE_ MUX_HS	INVERT_ MUX_HS	CROSSBARHS[4:0]				
<b>Reset</b>	0b	0b	0b	01110b				
<b>Access Type</b>	Write, Read	Write, Read	Write, Read	Write, Read				

BITFIELD	BITS	DESCRIPTION	DECODE
RSVD	7	<b>Reserved:</b> Do not change from default value	0: Reserved
FORCE_ MUX_HS	6	<b>Force Mux Output</b>	0: Input mapped to mux output 1: Force mux output low
INVERT_ MUX_HS	5	<b>Invert Mux Output</b>	0: Do not invert mux output 1: Invert mux output
CROSS- BARHS	4:0	<b>Crossbar Setting HS:</b> Select 1 of 16 input pins for HS. Default values connect HS with the corresponding named input pin.	00000: Mux sync signal from DIN0 00001: Mux sync signal from DIN1 01111: Mux sync signal from DIN15 1XXXX: <b>Do Not Use</b>

**crossbar (0x40)**

BIT	7	6	5	4	3	2	1	0
<b>Field</b>	RSVD	FORCE_MUX_VS	INVERT_MUX_VS	CROSSBARVS[4:0]				
<b>Reset</b>	0b	0b	0b	01111b				
<b>Access Type</b>	Write, Read	Write, Read	Write, Read	Write, Read				

BITFIELD	BITS	DESCRIPTION	DECODE
RSVD	7	<b>Reserved:</b> Do not change from default value	0: Reserved
FORCE_MUX_VS	6	<b>Force Mux Output</b>	0: Input mapped to mux output 1: Force mux output low
INVERT_MUX_VS	5	<b>Invert Mux Output</b>	0: Do not invert mux output 1: Invert mux output
CROSSBARVS	4:0	<b>Crossbar Setting VS:</b> Select 1 of 16 input pins for VS. Default values connect VS with the corresponding named input pin.	00000: Mux sync signal from DIN0 00001: Mux sync signal from DIN1 01111: Mux sync signal from DIN15 1XXXX: <b>Do Not Use</b>

**crossbar\_de (0x41)**

BIT	7	6	5	4	3	2	1	0
<b>Field</b>	RSVD	FORCE_MUX_DE	INVERT_MUX_DE	CROSSBARDE[4:0]				
<b>Reset</b>	0b	0b	0b	01101b				
<b>Access Type</b>	Write, Read	Write, Read	Write, Read	Write, Read				

BITFIELD	BITS	DESCRIPTION	DECODE
RSVD	7	<b>Reserved:</b> Do not change from default value	0: Reserved
FORCE_MUX_DE	6	<b>Force Mux Output</b>	0: Input mapped to mux output. 1: Force mux output low.
INVERT_MUX_DE	5	<b>Invert Mux Output</b>	0: Do not invert mux output. 1: Invert mux output.
CROSSBARDE	4:0	<b>Crossbar Setting DE:</b> Select 1 of 16 input pins for DE. Default values connect DE with DIN13.	00000: Mux sync signal from DIN0 00001: Mux sync signal from DIN1 01111: Mux sync signal from DIN15 1XXXX: <b>Do Not Use</b>

**link\_config (0x42)**

BIT	7	6	5	4	3	2	1	0
<b>Field</b>	LINE_CRC_LOC[1:0]		LINE_CRC_EN	MAX_RT_EN	RSVD	GPI_COMP_EN	GPI_RT_EN	GPO_EN
<b>Reset</b>	01b		0b	1b	1b	0b	1b	1b
<b>Access Type</b>	Write, Read		Write, Read	Write, Read	Write, Read	Write, Read	Write, Read	Write, Read

BITFIELD	BITS	DESCRIPTION	DECODE
LINE_CRC_LOC	7:6	<b>Line CRC Location:</b> Video line CRC insertion location	00: CRC insertion at [1..4] 01: CRC insertion at [5..8] 10: CRC insertion at [9..12] 11: CRC insertion at [13..16]
LINE_CRC_EN	5	<b>Line CRC Enable:</b> Video line CRC enable	0: Disable CRC 1: Enable CRC
MAX_RT_EN	4	<b>Maximum Retransmission Limit Enable</b>	0: Disable maximum retransmission limit 1: Enable maximum retransmission limit
RSVD	3	<b>Reserved:</b> Do not change from default value	1: Reserved
GPI_COMP_EN	2	<b>GPI Compensation Enable</b>	0: Disable GPI compensation 1: Enable GPI compensation
GPI_RT_EN	1	<b>GPI Retransmission Enable</b>	0: Disable GPI retransmission 1: Enable GPI retransmission
GPO_EN	0	<b>GPO Enable:</b> Enable GPO pin	0: Disable GPO pin 1: Enable GPO pin

**sync\_gen\_config (0x43)**

BIT	7	6	5	4	3	2	1	0
Field	RSVD	RSVD	GEN_VS	GEN_HS	GEN_DE	VS_TRIG	VTG_MODE[1:0]	
Reset	0b	0b	0b	0b	0b	1b	01b	
Access Type	Write, Read	Write, Read	Write, Read	Write, Read	Write, Read	Write, Read	Write, Read	

BITFIELD	BITS	DESCRIPTION	DECODE
RSVD	7	<b>Reserved:</b> Do not change from default value	0: Reserved
RSVD	6	<b>Reserved:</b> Do not change from default value	0: Reserved
GEN_VS	5	<b>VSYNC Generation:</b> Enable to generate VS output according to the timing definition	0: Disable VS output generation (VS used from input) 1: Enable VS output generation (VS internally generated)
GEN_HS	4	<b>HSYNC Generation:</b> Enable to generate HS output according to the timing definition	0: Disable HS output generation (HS used from input) 1: Enable HS output generation (HS internally generated)
GEN_DE	3	<b>DE Generation:</b> Enable to generate DE output according to the timing definition	0: Disable DE output generation (DE used from input) 1: Enable DE output generation (DE internally generated)
VS_TRIG	2	<b>VSYNC Trigger Edge Select</b>	0: VS trigger uses falling edge 1: VS trigger uses rising edge
VTG_MODE	1:0	<b>Video Timing Generator Mode</b>	00: VS input is tracked and then locked after three consecutive matches (three consecutive mismatches unlock tracking) 01: VS edge triggers one VS frame (current frame is extended/cut short to adjust timing to next trigger) 10: VS edge triggers VS generation (current frame is extended/cut short to adjust timing to next trigger) 11: Same as above

**vs\_dly (0x44 to 0x46)**

<b>BIT</b>	<b>7</b>	<b>6</b>	<b>5</b>	<b>4</b>	<b>3</b>	<b>2</b>	<b>1</b>	<b>0</b>
<b>Field</b>	VS_DLY[7:0]							
<b>Reset</b>	0000000b							
<b>Access Type</b>	Write, Read							

<b>BITFIELD</b>	<b>BITS</b>	<b>DESCRIPTION</b>	<b>DECODE</b>
VS_DLY	7:0	<b>VSYNC Delay:</b> VS delay in terms of PCLK cycles; the output VS delay by VS_DELAY cycles from the input VS.	00000000: Value is 0 00000001: Value is 1 11111111: Value is 255

**vs\_h (0x47 to 0x49)**

<b>BIT</b>	<b>7</b>	<b>6</b>	<b>5</b>	<b>4</b>	<b>3</b>	<b>2</b>	<b>1</b>	<b>0</b>
<b>Field</b>	VS_H[7:0]							
<b>Reset</b>	0000000b							
<b>Access Type</b>	Write, Read							

<b>BITFIELD</b>	<b>BITS</b>	<b>DESCRIPTION</b>	<b>DECODE</b>
VS_H	7:0	<b>VSYNC High:</b> VS high period in terms of PCLK cycles.	00000000: Value is 0 00000001: Value is 1 11111111: Value is 255

**vs\_l (0x4A to 0x4C)**

<b>BIT</b>	<b>7</b>	<b>6</b>	<b>5</b>	<b>4</b>	<b>3</b>	<b>2</b>	<b>1</b>	<b>0</b>
<b>Field</b>	VS_L[7:0]							
<b>Reset</b>	0000000b							
<b>Access Type</b>	Write, Read							

<b>BITFIELD</b>	<b>BITS</b>	<b>DESCRIPTION</b>	<b>DECODE</b>
VS_L	7:0	<b>VSYNC Low:</b> VS low period in terms of PCLK cycles	00000000: Value is 0 00000001: Value is 1 11111111: Value is 255



**cxtp (0x4D)**

BIT	7	6	5	4	3	2	1	0
Field	RSVD	CXTP	RSVD	RSVD	VSYNC_ INV	HSYNC_ INV	DE_INV	RSVD
Reset	Xb	0b	0b	0b	0b	0b	0b	0b
Access Type	Write, Read	Write, Read	Write, Read	Write, Read	Write, Read	Write, Read	Write, Read	Write, Read

BITFIELD	BITS	DESCRIPTION	DECODE
RSVD	7	<b>Reserved:</b> Do not change from default value	X: Reserved
CXTP	6	<b>Coax/Twisted Pair Select</b> Default value depends on the state of the CONF0, CONF1 inputs	0: Use differential output (STP mode) 1: Use dual single ended outputs (coax)
RSVD	5	<b>Reserved:</b> Do not change from default value	0: Reserved
RSVD	4	<b>Reserved:</b> Do not change from default value	0: Reserved
VSYNC_ INV	3	<b>VSYNC Inversion:</b> Invert output VSYNC in TIMING GEN	0: Do not invert VS in timing generator 1: Invert VS in timing generator
HSYNC_ INV	2	<b>HSYNC Inversion:</b> Invert output HSYNC in TIMING GEN	00: Value is zero 01: Value is two 10 11
DE_INV	1	<b>DE Inversion:</b> Invert output DE in TIMING GEN	00: Value is zero 01: Value is two 10 11
RSVD	0	<b>Reserved:</b> Do not change from default value	0: Reserved

**hs\_dly (0x4E to 0x50)**

BIT	7	6	5	4	3	2	1	0
Field	HS_DLY[7:0]							
Reset	00000000b							
Access Type	Write, Read							

BITFIELD	BITS	DESCRIPTION	DECODE
HS_DLY	7:0	<b>VSYNC to HSYNC Delay:</b> VS edge to the rising edge of the first HS in terms of PCLK cycles (bits [15:8])	00000000: Value is 0 00000001: Value is 1 11111111: Value is 255

**rsvd (0x51 to 0x53, 0x5D to 0x5F)**

BIT	7	6	5	4	3	2	1	0
Field	RSVD	RSVD	RSVD	RSVD	RSVD	RSVD	RSVD	RSVD
Reset	0b	0b	0b	0b	0b	0b	0b	0b
Access Type	Write, Read	Write, Read	Write, Read	Write, Read	Write, Read	Write, Read	Write, Read	Write, Read

BITFIELD	BITS	DESCRIPTION	DECODE
RSVD	7	<b>Reserved:</b> Do not change from default value	0: Reserved
RSVD	6	<b>Reserved:</b> Do not change from default value	0: Reserved
RSVD	5	<b>Reserved:</b> Do not change from default value	0: Reserved
RSVD	4	<b>Reserved:</b> Do not change from default value	0: Reserved
RSVD	3	<b>Reserved:</b> Do not change from default value	0: Reserved
RSVD	2	<b>Reserved:</b> Do not change from default value.	0: Reserved
RSVD	1	<b>Reserved:</b> Do not change from default value	0: Reserved
RSVD	0	<b>Reserved:</b> Do not change from default value	0: Reserved

**hs\_h (0x54, 0x55)**

<b>BIT</b>	<b>7</b>	<b>6</b>	<b>5</b>	<b>4</b>	<b>3</b>	<b>2</b>	<b>1</b>	<b>0</b>
<b>Field</b>	HS_H[7:0]							
<b>Reset</b>	0000000b							
<b>Access Type</b>	Write, Read							

<b>BITFIELD</b>	<b>BITS</b>	<b>DESCRIPTION</b>	<b>DECODE</b>
HS_H	7:0	<b>HSYNC High Period:</b> HS high period in terms of PCLK cycles	00000000: Value is 0 00000001: Value is 1 11111111: Value is 255

**hs\_l (0x56, 0x57)**

<b>BIT</b>	<b>7</b>	<b>6</b>	<b>5</b>	<b>4</b>	<b>3</b>	<b>2</b>	<b>1</b>	<b>0</b>
<b>Field</b>	HS_L[7:0]							
<b>Reset</b>	0000000b							
<b>Access Type</b>	Write, Read							

<b>BITFIELD</b>	<b>BITS</b>	<b>DESCRIPTION</b>	<b>DECODE</b>
HS_L	7:0	<b>HSYNC Low Period:</b> HS low period in terms of PCLK cycles.	00000000: Value is 0 00000001: Value is 1 11111111: Value is 255

**hs\_cnt (0x58, 0x59)**

<b>BIT</b>	<b>7</b>	<b>6</b>	<b>5</b>	<b>4</b>	<b>3</b>	<b>2</b>	<b>1</b>	<b>0</b>
<b>Field</b>	HS_CNT[7:0]							
<b>Reset</b>	0000000b							
<b>Access Type</b>	Write, Read							

<b>BITFIELD</b>	<b>BITS</b>	<b>DESCRIPTION</b>	<b>DECODE</b>
HS_CNT	7:0	<b>HSYNC Count:</b> Lines per panel (bits [7:0]).	00000000: Value is 0 00000001: Value is 1 11111111: Value is 255

**de\_dly (0x5A to 0x5C)**

<b>BIT</b>	<b>7</b>	<b>6</b>	<b>5</b>	<b>4</b>	<b>3</b>	<b>2</b>	<b>1</b>	<b>0</b>
<b>Field</b>	DE_DLY[7:0]							
<b>Reset</b>	0000000b							
<b>Access Type</b>	Write, Read							

BITFIELD	BITS	DESCRIPTION	DECODE
DE_DLY	7:0	<b>VSYSYNC to DE</b> VS falling edge to the rising edge of the first DE in terms of PCLK cycles.	00000000: Value is 0. 00000001: Value is 1. 11111111: Value is 255.

**de\_h (0x60, 0x61)**

<b>BIT</b>	<b>7</b>	<b>6</b>	<b>5</b>	<b>4</b>	<b>3</b>	<b>2</b>	<b>1</b>	<b>0</b>
<b>Field</b>	DE_H[7:0]							
<b>Reset</b>	0000000b							
<b>Access Type</b>	Write, Read							

BITFIELD	BITS	DESCRIPTION	DECODE
DE_H	7:0	<b>DE High Period:</b> DE high period in terms of PCLK cycles.	00000000: Value is 0 00000001: Value is 1 11111111: Value is 255

**de\_l (0x62, 0x63)**

<b>BIT</b>	<b>7</b>	<b>6</b>	<b>5</b>	<b>4</b>	<b>3</b>	<b>2</b>	<b>1</b>	<b>0</b>
<b>Field</b>	DE_L[7:0]							
<b>Reset</b>	0000000b							
<b>Access Type</b>	Write, Read							

BITFIELD	BITS	DESCRIPTION	DECODE
DE_L	7:0	<b>DE Low Period:</b> DE low period in terms of PCLK cycles	00000000: Value is 0 00000001: Value is 1 11111111: Value is 255

**de\_cnt (0x64, 0x65)**

<b>BIT</b>	<b>7</b>	<b>6</b>	<b>5</b>	<b>4</b>	<b>3</b>	<b>2</b>	<b>1</b>	<b>0</b>
<b>Field</b>	DE_CNT[7:0]							
<b>Reset</b>	00000000b							
<b>Access Type</b>	Write, Read							

<b>BITFIELD</b>	<b>BITS</b>	<b>DESCRIPTION</b>	<b>DECODE</b>
DE_CNT	7:0	<b>DE Count:</b> Active lines per panel	00000000: Value is 0 00000001: Value is 1 11111111: Value is 255

**prbs\_type (0x66)**

<b>BIT</b>	<b>7</b>	<b>6</b>	<b>5</b>	<b>4</b>	<b>3</b>	<b>2</b>	<b>1</b>	<b>0</b>
<b>Field</b>	RSVD[1:0]		PRBS_TYPE	REV_FAST	DE_EN	DIS_RWAKE	RSVD	CXSEL
<b>Reset</b>	01b		1b	0b	0b	0b	0b	1b
<b>Access Type</b>	Write, Read		Write, Read	Write, Read	Write, Read	Write, Read	Write, Read	Write, Read

<b>BITFIELD</b>	<b>BITS</b>	<b>DESCRIPTION</b>	<b>DECODE</b>
RSVD	7:6	<b>Reserved:</b> Do not change from default value	01: Reserved
PRBS_TYPE	5	<b>PRBS Type:</b> PRBS type select	0: Select legacy PRBS mode 1: Select MAX9271–MAX9273 PRBS mode
REV_FAST	4	<b>Reverse Channel Fast-Mode Enable</b>	0: Disable reverse channel fast mode 1: Enable reverse channel fast mode
DE_EN	3	<b>DE Enable:</b> Enable processing separate HS and DE signals	0: Disable separate processing of HS and DE signals 1: Enable separate processing of HS and DE signals
DIS_RWAKE	2	<b>Disable Remote Wake-Up:</b> Disable wake-up receiver	0: Do not disable remote wake-up receiver 1: Disable remote wake-up receiver
RSVD	1	<b>Reserved:</b> Do not change from default value	0: Reserved
CXSEL	0	<b>Coax Select</b>	0: Coax cable connected to inverting output 1: Coax cable connected to noninverting output

**dbl\_align\_to (0x67)**

BIT	7	6	5	4	3	2	1	0
Field	RSVD[1:0]		AUTO_CLINK	RSVD	RSVD	DBL_ALIGN_TO[2:0]		
Reset	11b		0b	0b	0b	111b		
Access Type	Write, Read		Write, Read	Write, Read	Write, Read	Write, Read		

BITFIELD	BITS	DESCRIPTION	DECODE
RSVD	7:6	<b>Reserved:</b> Do not change from default value	11: Reserved
AUTO_CLINK	5	<b>Auto Configuration Link:</b> Automatic control of configuration link	0: Enable configuration link only when CLINKEN = 1 and SEREN = 0 1: Automatically enable configuration link when SEREN = 1 and PCLKDET = 0
RSVD	4	<b>Reserved:</b> Do not change from default value	0: Reserved
RSVD	3	<b>Reserved:</b> Do not change from default value	0: Reserved
DBL_ALIGN_TO	2:0	<b>Double Alignment Mode:</b> Sets the alignment mode when DBL = 1 in the serializer and DBL = 0 in the deserializer. Set DBL_ALIGN_TO = 000 when an external high-low signal is used (EN_HI_LO = 1).	000: Align at each rising edge of HS. Turn off alignment after HS is low (MAX9286). Use this setting when an external high/low signal is used. 001: Do not use 010: Force align 011: Do not use 100: Align at each rising edge of HS 101: Align at each rising edge of DE 110: Force align 111: No alignment done while in DBL mode

**cc\_crc\_length (0x68)**

BIT	7	6	5	4	3	2	1	0
Field	RSVD	RSVD[2:0]			RSVD[1:0]		CC_CRC_LENGTH[1:0]	
Reset	0b	001b			10b		01b	
Access Type	Write, Read	Write, Read			Write, Read		Write, Read	

BITFIELD	BITS	DESCRIPTION	DECODE
RSVD	7	<b>Reserved:</b> Do not change from default value	0: Reserved
RSVD	6:4	<b>Reserved:</b> Do not change from default value	001: Reserved
RSVD	3:2	<b>Reserved:</b> Do not change from default value	10: Reserved
CC_CRC_LENGTH	1:0	<b>Control-Channel CRC Length</b>	00: 1-bit CC CRC length 01: 5-bit CC CRC length 10: 8-bit CC CRC length 11: Do not use

**hi\_lo (0x69)**

BIT	7	6	5	4	3	2	1	0
<b>Field</b>	RSVD	EN_HI_LO	INVERT_HI_LO	CROSSBAR_HI_LO[4:0]				
<b>Reset</b>	0b	0b	0b	01111b				
<b>Access Type</b>	Write, Read	Write, Read	Write, Read	Write, Read				

BITFIELD	BITS	DESCRIPTION	DECODE
RSVD	7	<b>Reserved:</b> Do not change from default value	0: Reserved
EN_HI_LO	6	<b>Enable High/Low Signal Alignment</b>	0: Do not align using a Hi-Lo signal 1: Use a Hi-Lo signal to align input data
INVERT_HI_LO	5	<b>Invert High/Low Signal Alignment</b>	0: Do not invert Hi-Lo signal 1: Invert Hi-Lo signal
CROSSBAR_HI_LO	4:0	<b>Crossbar High Low:</b> Select 1 of 16 input pins for the Hi-Lo signal. Default values connect the Hi-Lo signal to the VS input pin (effective when DBL_ALIGN_TO = 000).	00000: Mux Hi-Lo signal from DIN0 00001: Mux Hi-Lo signal from DIN1 01111: Mux Hi-Lo signal from DIN15 1XXXX: <b>Do Not Use</b>

**rsvd\_96 (0x96)**

BIT	7	6	5	4	3	2	1	0
<b>Field</b>	RSVD	RSVD	RSVD	RSVD	RSVD	RSVD	RSVD[1:0]	
<b>Reset</b>	0b	0b	0b	0b	0b	0b	10b	
<b>Access Type</b>	Write, Read	Write, Read	Write, Read	Write, Read	Write, Read	Write, Read	Write, Read	

BITFIELD	BITS	DESCRIPTION	DECODE
RSVD	7	<b>Reserved:</b> Do not change from default value	0: Reserved
RSVD	6	<b>Reserved:</b> Do not change from default value	0: Reserved
RSVD	5	<b>Reserved:</b> Do not change from default value	0: Reserved
RSVD	4	<b>Reserved:</b> Do not change from default value	0: Reserved
RSVD	3	<b>Reserved:</b> Do not change from default value	0: Reserved
RSVD	2	<b>Reserved:</b> Do not change from default value	0: Reserved
RSVD	1:0	<b>Reserved:</b> Do not change from default value	10: Reserved

**rsvd\_97 (0x97)**

BIT	7	6	5	4	3	2	1	0
Field	RSVD	RSVD	RSVD	RSVD	RSVD	RSVD[2:0]		
Reset	0b	0b	0b	1b	1b	111b		
Access Type	Write, Read	Write, Read	Write, Read	Write, Read	Write, Read	Write, Read		

BITFIELD	BITS	DESCRIPTION	DECODE
RSVD	7	<b>Reserved:</b> Do not change from default value	0: Reserved
RSVD	6	<b>Reserved:</b> Do not change from default value	0: Reserved
RSVD	5	<b>Reserved:</b> Do not change from default value	0: Reserved
RSVD	4	<b>Reserved:</b> Do not change from default value	1: Reserved
RSVD	3	<b>Reserved:</b> Do not change from default value	1: Reserved
RSVD	2:0	<b>Reserved:</b> Do not change from default value	111: Reserved

**rsvd\_98 (0x98)**

BIT	7	6	5	4	3	2	1	0
Field	RSVD[1:0]		RSVD[2:0]			RSVD[2:0]		
Reset	01b		001b			010b		
Access Type	Write, Read		Write, Read			Write, Read		

BITFIELD	BITS	DESCRIPTION	DECODE
RSVD	7:6	<b>Reserved:</b> Do not change from default value	01: Reserved
RSVD	5:3	<b>Reserved:</b> Do not change from default value	001: Reserved
RSVD	2:0	<b>Reserved:</b> Do not change from default value	010: Reserved



**rsvd\_99 (0x99)**

BIT	7	6	5	4	3	2	1	0
Field	RSVD	RSVD	RSVD	RSVD	RSVD	RSVD	RSVD[1:0]	
Reset	0b	0b	0b	0b	1b	1b	01b	
Access Type	Write, Read	Write, Read	Write, Read	Write, Read	Write, Read	Write, Read	Write, Read	

BITFIELD	BITS	DESCRIPTION	DECODE
RSVD	7	<b>Reserved:</b> Do not change from default value	0: Reserved
RSVD	6	<b>Reserved:</b> Do not change from default value	0: Reserved
RSVD	5	<b>Reserved:</b> Do not change from default value	0: Reserved
RSVD	4	<b>Reserved:</b> Do not change from default value	0: Reserved
RSVD	3	<b>Reserved:</b> Do not change from default value	1: Reserved
RSVD	2	<b>Reserved:</b> Do not change from default value	1: Reserved
RSVD	1:0	<b>Reserved:</b> Do not change from default value	01: Reserved

**pktcc\_en (0x9A)**

BIT	7	6	5	4	3	2	1	0
Field	RSVD[1:0]		RSVD[1:0]		PKTCC_EN	RSVD[1:0]		RSVD
Reset	00b		01b		0b	00b		0b
Access Type	Write, Read		Write, Read		Write, Read	Write, Read		Write, Read

BITFIELD	BITS	DESCRIPTION	DECODE
RSVD	7:6	<b>Reserved:</b> Do not change from default value	00: Reserved
RSVD	5:4	<b>Reserved:</b> Do not change from default value	01: Reserved
PKTCC_EN	3	<b>Packet-Based Control-Channel-Mode Enable</b>	0: Disable packet-based control-channel mode 1: Enable packet-based control-channel mode
RSVD	2:1	<b>Reserved:</b> Do not change from default value	00: Reserved
RSVD	0	<b>Reserved:</b> Do not change from default value	0: Reserved

**rsvd\_c8 (0xC8)**

BIT	7	6	5	4	3	2	1	0
Field	RSVD	RSVD	RSVD	RSVD	RSVD	RSVD	RSVD	RSVD
Reset	0b	Xb	Xb	Xb	0b	0b	0b	0b
Access Type	Write, Read	Read Only	Read Only	Read Only	Write, Read	Read Only	Write, Read	Read Only

BITFIELD	BITS	DESCRIPTION	DECODE
RSVD	7	<b>Reserved:</b> Do not change from default value	0: Reserved
RSVD	6	<b>Reserved:</b> Do not change from default value	X: Reserved
RSVD	5	<b>Reserved:</b> Do not change from default value	X: Reserved
RSVD	4	<b>Reserved:</b> Do not change from default value	X: Reserved
RSVD	3	<b>Reserved:</b> Do not change from default va	0: Reserved
RSVD	2	<b>Reserved</b>	0: Reserved
RSVD	1	<b>Reserved:</b> Do not change from default value	0: Reserved
RSVD	0	<b>Reserved</b>	0: Reserved

**rsvd\_c9 (0xC9)**

BIT	7	6	5	4	3	2	1	0
Field	RSVD[7:0]							
Reset	XXXXXXXXb							
Access Type	Read Only							

BITFIELD	BITS	DESCRIPTION	DECODE
RSVD	7:0	<b>Reserved:</b> Do not change from default value	XXXXXXXX: Reserved

**rsvd\_fc (0xFC)**

BIT	7	6	5	4	3	2	1	0
Field	RSVD	RSVD	RSVD	RSVD	RSVD	RSVD	RSVD	RSVD
Reset	0b	0b	0b	0b	0b	0b	0b	0b
Access Type	Write, Read	Write, Read	Write, Read	Write, Read	Write, Read	Write, Read	Write, Read	Write, Read

BITFIELD	BITS	DESCRIPTION	DECODE
RSVD	7	<b>Reserved:</b> Do not change from default value	0: Reserved
RSVD	6	<b>Reserved:</b> Do not change from default value	0: Reserved
RSVD	5	<b>Reserved:</b> Do not change from default value	0: Reserved
RSVD	4	<b>Reserved:</b> Do not change from default value	0: Reserved
RSVD	3	<b>Reserved:</b> Do not change from default value	0: Reserved
RSVD	2	<b>Reserved:</b> Do not change from default value	0: Reserved
RSVD	1	<b>Reserved:</b> Do not change from default value	0: Reserved
RSVD	0	<b>Reserved:</b> Do not change from default value	0: Reserved

**rsvd\_fd (0xFD)**

BIT	7	6	5	4	3	2	1	0
Field	RSVD[7:0]							
Reset	00000000b							
Access Type	Write, Read							

BITFIELD	BITS	DESCRIPTION	DECODE
RSVD	7:0	<b>Reserved:</b> Do not change from default value	00000000: Reserved

**rsvd\_fe (0xFE)**

BIT	7	6	5	4	3	2	1	0
Field	RSVD[3:0]				RSVD[3:0]			
Reset	0000b				0000b			
Access Type	Write, Read				Write, Read			

BITFIELD	BITS	DESCRIPTION	DECODE
RSVD	7:4	<b>Reserved:</b> Do not change from default value	0000: Reserved
RSVD	3:0	<b>Reserved:</b> Do not change from default value	0000: Reserved

**rsvd\_ff (0xFF)**

BIT	7	6	5	4	3	2	1	0
Field	RSVD	RSVD	RSVD	RSVD	RSVD[3:0]			
Reset	0b	0b	0b	0b	XXXXb			
Access Type	Write, Read	Write, Read	Write, Read	Write, Read	Read Only			

BITFIELD	BITS	DESCRIPTION	DECODE
RSVD	7	<b>Reserved:</b> Do not change from default value	0: Reserved
RSVD	6	<b>Reserved:</b> Do not change from default value	0: Reserved
RSVD	5	<b>Reserved:</b> Do not change from default value	0: Reserved
RSVD	4	<b>Reserved:</b> Do not change from default value	0: Reserved
RSVD	3:0	<b>Reserved:</b> Do not change from default value	XXXX: Reserved

## Applications Information

### Parallel Interface

The CMOS parallel interface-data width is programmable and depends on the application. Using a larger width (BWS = 1) results in a lower-pixel clock rate, while a smaller width (BWS = 0) allows a higher-pixel clock rate.

### Bus Data Width

The bus data width depends on the selected modes. The available bus width is less when using error detection or

when in double mode (DBL = 1). [Table 3](#) shows the available bit widths and default mapping for various modes.

### Bus Data Rates

The bus data rate depends on the settings for BWS and DBL. [Table 4](#) lists the available PCLK rates available for different bus-width settings. For lower PCLK rates, set DBL = 0 (if DBL = 1 in both the serializer and deserializer).

**Table 3. Input Data-Width Selection**

REGISTER BIT SETTINGS					INPUT MAPPING (WITH 96706)	INPUT MAPPING (WITH OTHER)
DBL	BWS	HIBW	PXL_CRC	HVEN		
1	1	—	1	1	DIN11:0, HS, VS	DIN11:0, HS, VS
1	1	—	1	0	DIN11:0	DIN11:0
1	1	—	0	1	DIN11:0**, HS, VS	DIN13:0*, HS, VS
1	1	—	0	0	DIN13:0**	DIN14:0
1	0	1	1	—	DIN8:0, HS, VS	DIN8:0, HS, VS
1	0	1	0	—	DIN11:0, HS, VS	DIN11:0, HS, VS
1	0	0	1	1	DIN7:0, HS, VS	DIN7:0, HS, VS
1	0	0	1	0	DIN7:0	DIN7:0
1	0	0	0	1	DIN10:0, HS, VS	DIN10:0, HS, VS
1	0	0	0	0	DIN10:0	DIN10:0
0	1	—	1	1	DIN11:0**, HS, VS	DIN13:0*, HS, VS
0	1	—	1	0	DIN13:0**	DIN15:0*
0	1	—	0	1	DIN11:0**, HS, VS	DIN13:0*, HS, VS
0	1	—	0	0	DIN13:0*	DIN15:0*
0	0	1	-	—	DIN11:0**, HS, VS	DIN13:0*, HS, VS
0	0	0	1	1	DIN11:0**, HS, VS	DIN13:0*, HS, VS
0	0	0	1	0	DIN13:0**	DIN15:0*
0	0	0	0	1	DIN11:0**, HS, VS	DIN13:0*, HS, VS
0	0	0	0	0	DIN13:0**	DIN15:0*

\* The input bit width is limited by the number of available inputs.

\*\* The input bit width is limited by the number of available outputs on the deserializer.

**Table 4. Data-Rate Selection**

DBL	BWS	HIBW	PCLK RANGE (MHz)
1	1	0	25 to 87
1	0	0	33.3 to 116
1	0	1	73.3 to 116
0	1	0	12.5 to 43.5
0	0	0	16.7 to 58
0	0	1	36.6 to 58

**Crossbar Switch**

By default, the crossbar switch connects the serializer input pins DIN\_ and HS/VS (when HV encoding is used) to the corresponding deserializer output pins DOUT\_ and HS/VS. Reprogram the crossbar switch when changing the input or output pin assignments, or when connecting to devices that do not have a DBL = 1 mode.

**Crossbar-Switch Programming**

Each crossbar-switch output can select any of the 16 DIN\_ inputs for either high or low words (when DBL = 1) for a total of 32 possible inputs. Multiple outputs can share the same input. HS, VS, and DE remain the same for both word halves, and should be programmed to use the low-word input of the corresponding pin. To invert an input data bit, set the respective INVERT\_MUX\_ = 1. To force an output low, (and ignore the input) set the FORCE\_MUX\_ bit = 1. To force an output high set both INVERT\_MUX\_ and FORCE\_MUX\_ = 1.

**Recommended Crossbar-Switch Program Procedure**

The procedure to program the crossbar switch depends on the DBL settings on the serializer and deserializer. Devices without double mode can be assumed to have DBL = 0.

• **Both Devices' DBL Set to the Same Value**

1. For the crossbar-output equivalent of DIN0 (XBO0, XBO16) select which pin to map (e.g., DIN4 → XBI4, XBI20).

2. Set the low- and high-input crossbar bits (CROSSBAR0, CROSSBAR 16) to the desired selected mapped input (e.g., CROSSBAR0 = 00100, CROSSBAR16 = 10100).

3. Repeat for the other crossbar outputs, making sure the set of high and low crossbar outputs are assigned to the same crossbar input set. In general, XBO[i] and XBO[i+16] should be assigned to XBI[j] and XBI[j+16].

4. For XBOHS, XBOVS, and XBODE, set crossbar to use the low-input pins (CROSSBAR\_ = 00000 to 01111). Note that HS, VS, and DE use both the low and high input.

• **Both Devices' DBL Do Not Match**

1. [Table 5](#), [Table 6](#), and [Table 7](#) list which crossbar output (XBO\_) maps to each serial bit.

2. For each crossbar output, select which pin and high/low clock cycle (if needed) to map (e.g., DIN4 low input).

3. Set the crossbar bits (CROSSBAR\_) to select the desired selected mapped input (e.g., CROSSBAR0 = 00100 maps DIN4 low input to XBO0).

4. Repeat for the other crossbar outputs; any unused serial bits should have a force low mapped to the respective crossbar output.

5. For XBOHS, XBOVS, and XBODE, set crossbar to use the low-input pins (CROSSBAR\_ = 00000 to 01111). Note that HS, VS, and DE use both the low and high input.

**Table 5. Crossbar Output to Serial Link Map (D23:0)**

BIT SETTING						SERIAL BITS																								
DB	HV	BW	HB	CR	DE	0	1	2	3	4	5	6	7	8	9	10	11	12	13	14	15	16	17	18	19	20	21	22	23	
0	0	0	0	0	X	0	1	2	3	4	5	6	7	8	9	10	11	12	13	14	15	Z	Z	Z	Z	Z	Z	Z	F	P
0	0	0	0	1	X	0	1	2	3	4	5	6	7	8	9	10	11	12	13	14	15	F	E	E	E	E	E	E	E	P
0	0	0	1	0	X	0	1	2	3	4	5	6	7	8	9	10	11	12	13	14	15	Z	Z	Z	Z	Z	Z	F	P	
0	0	0	1	1	X	0	1	2	3	4	5	6	7	8	9	10	11	12	13	14	15	Z	Z	Z	F	E	E	E	P	
0	0	1	0	0	X	0	1	2	3	4	5	6	7	8	9	10	11	12	13	14	15	Z	Z	Z	Z	Z	Z	Z	Z	
0	0	1	0	1	X	0	1	2	3	4	5	6	7	8	9	10	11	12	13	14	15	Z	Z	Z	Z	Z	Z	Z	Z	
0	1	0	0	0	X	0	1	2	3	4	5	6	7	8	9	10	11	12	13	14	15	Z	Z	Z	Z	Z	Z	F	P	
0	1	0	0	1	X	0	1	2	3	4	5	6	7	8	9	10	11	12	13	14	15	F	E	E	E	E	E	E	P	
0	1	1	0	0	X	0	1	2	3	4	5	6	7	8	9	10	11	12	13	14	15	Z	Z	Z	Z	Z	Z	Z	Z	
0	1	1	0	1	X	0	1	2	3	4	5	6	7	8	9	10	11	12	13	14	15	Z	Z	Z	Z	Z	Z	Z	Z	
1	0	0	0	0	X	16	17	18	19	20	21	22	23	24	25	26	0	1	2	3	4	5	6	7	8	9	10	F	P	
1	0	0	0	1	X	16	17	18	19	20	21	22	23	0	1	2	3	4	5	6	7	F	E	E	E	E	E	E	P	
1	0	0	1	0	X	16	17	18	19	20	21	22	23	24	25	26	27	0	1	2	3	4	5	6	7	8	Z	F	P	

**Table 5. Crossbar Output to Serial Link Map (D23:0) (continued)**

BIT SETTING						SERIAL BITS																							
DB	HV	BW	HB	CR	DE	0	1	2	3	4	5	6	7	8	9	10	11	12	13	14	15	16	17	18	19	20	21	22	23
1	0	0	1	1	X	16	17	18	19	20	21	22	23	24	0	1	2	3	4	5	6	7	8	Z	F	E	E	E	P
1	0	1	0	0	X	16	17	18	19	20	21	22	23	24	25	26	27	28	29	30	0	1	2	3	4	5	6	7	8
1	0	1	0	1	1	16	17	18	19	20	21	22	23	24	25	26	DH	0	1	2	3	4	5	6	7	8	9	10	DL
1	0	1	0	1	0	16	17	18	19	20	21	22	23	24	25	26	27	0	1	2	3	4	5	6	7	8	9	10	11
1	1	0	0	0	1	16	17	18	19	20	21	22	23	24	25	DH	0	1	2	3	4	5	6	7	8	9	DL	F	P
1	1	0	0	0	0	16	17	18	19	20	21	22	23	24	25	26	0	1	2	3	4	5	6	7	8	9	10	F	P
1	1	0	0	1	1	16	17	18	19	20	21	22	DH	0	1	2	3	4	5	6	DL	F	E	E	E	E	E	E	P
1	1	0	0	1	0	16	17	18	19	20	21	22	23	0	1	2	3	4	5	6	7	F	E	E	E	E	E	E	P
1	1	1	0	0	X	16	17	18	19	20	21	22	23	24	25	26	27	28	29	30	0	1	2	3	4	5	6	7	8
1	1	1	0	1	1	16	17	18	19	20	21	22	23	24	25	26	DH	0	1	2	3	4	5	6	7	8	9	10	DL
1	1	1	0	1	0	16	17	18	19	20	21	22	23	24	25	26	27	0	1	2	3	4	5	6	7	8	9	10	11

**Table 6. Crossbar Output to Serial Link Map (D31:24 and Special Packets)**

BIT SETTING														SPECIAL PACKETS							
DB	HV	BW	HB	CR	DE	24	25	26	27	28	29	30	31	C0	C1	C2	C3	HS	VS	DE	
0	0	0	0	0	X	—	—	—	—	—	—	—	—	—	—	—	—	—	—	—	
0	0	0	0	1	X	—	—	—	—	—	—	—	—	—	—	—	—	—	—	—	
0	0	0	1	0	X	Z	Z	Z	—	—	—	—	—	Z	Z	Z	Z	H	V	D	
0	0	0	1	1	X	E	E	E	—	—	—	—	—	Z	Z	Z	Z	H	V	D	
0	0	1	0	0	X	Z	Z	Z	Z	Z	Z	F	P	—	—	—	—	—	—	—	
0	0	1	0	1	X	F	E	E	E	E	E	E	P	—	—	—	—	—	—	—	
0	1	0	0	0	X	—	—	—	—	—	—	—	—	—	—	—	—	H	V	—	
0	1	0	0	1	X	—	—	—	—	—	—	—	—	—	—	—	—	H	V	—	
0	1	1	0	0	X	Z	Z	Z	Z	Z	Z	F	P	—	—	—	—	H	V	—	
0	1	1	0	1	X	F	E	E	E	E	E	E	P	—	—	—	—	H	V	—	
1	0	0	0	0	X	—	—	—	—	—	—	—	—	—	—	—	—	—	—	—	
1	0	0	0	1	X	—	—	—	—	—	—	—	—	—	—	—	—	—	—	—	
1	0	0	1	0	X	9	10	11	—	—	—	—	—	A	Z	A	A	H	V	D	
1	0	0	1	1	X	E	E	E	—	—	—	—	—	A	Z	A	A	H	V	D	
1	0	1	0	0	X	9	10	11	12	13	14	F	P	—	—	—	—	—	—	—	
1	0	1	0	1	1	F	E	E	E	E	E	E	P	—	—	—	—	—	—	—	
1	0	1	0	1	0	F	E	E	E	E	E	E	P	—	—	—	—	—	—	—	
1	1	0	0	0	1	—	—	—	—	—	—	—	—	—	—	—	—	HH/L	VH/L	—	
1	1	0	0	0	0	—	—	—	—	—	—	—	—	—	—	—	—	HH/L	VH/L	—	
1	1	0	0	1	1	—	—	—	—	—	—	—	—	—	—	—	—	HH/L	VH/L	—	
1	1	0	0	1	0	—	—	—	—	—	—	—	—	—	—	—	—	HH/L	VH/L	—	
1	1	1	0	0	X	9	10	11	12	13	14	F	P	—	—	—	—	HH/L	VH/L	—	
1	1	1	0	1	1	F	E	E	E	E	E	E	P	—	—	—	—	HH/L	VH/L	—	
1	1	1	0	1	0	F	E	E	E	E	E	E	P	-	-	-	-	HH/L	VH/L	-	

Table 7. Legend

BIT SETTINGS		MAP INPUTS	
DB	Double-mode bit DBL	H	HSYNC ( when DBL = 0 or HIBW = 1)
HV	H/V Encoding bit HVEN	V	VSYNC ( when DBL = 0 or HIBW = 1)
BW	BWS bit	D	DE ( when DBL = 0 or HIBW = 1)
HB	HIBW bit	HH	HSYNC (high word, DBL = 1)
CR	PXL_CRC bit	VH	VSYNC (high word, DBL = 1)
DE	DE = 1 when DEEN = 1 and not processed in RGB888 mode	DH	DE (high word, DBL = 1)
X	1 or 0	HL	HSYNC (low word, DBL = 1)
<b>SPECIAL PACKETS</b>		VL	VSYNC (low word, DBL = 1)
C0	CNT_0	DL	DE (low word, DBL = 1)
C1	CNT_1	#	XBO output from crossbar switch
C2	CNT_2	F	Internal forward control-channel bit
C3	CNT_3	E	Internal pixel CRC bit
<b>BIT COLOR</b>		P	Internal pixel parity bit
	Output bits from crossbar	—	Serial bit not sent
	Internal bits	Z	Zero
	Other output bits	A	Internal alignment bit (used when HIBW=1)
	Output bits from sync		

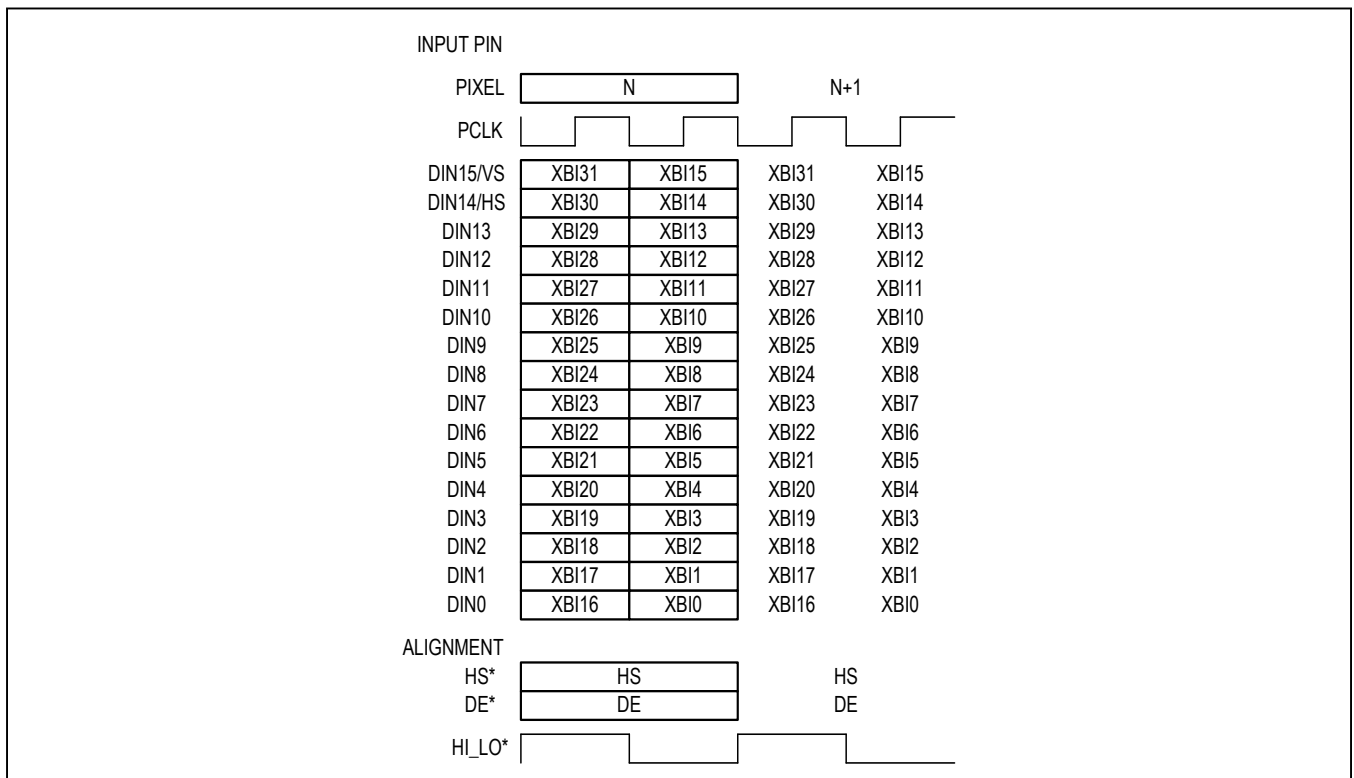

Figure 20. Crossbar-Switch Default Mapping



### Timing-Generator Programming

Timing-generator parameters are stored in the registers as unsigned integers as PCLK periods. To prevent output glitches, program all timing-generator parameters while the device is in configuration-link mode, or when PCLK is not applied. By default, the timing generator is set to single trigger, and is disabled. Figure 18 show the timing waveforms under the default conditions with rising-edge trigger, and noninverted signals. Do not program the HSYNC or DE signals such that the total length exceeds the length of a VSYNC period (Table 8). All delay parameters are positive. To implement a negative delay, set the delay value subtracted from the VSYNC period (e.g., a delay value of  $VS\_HIGH + VS\_LOW - N$  creates a delay of  $-N$  PCLK cycles). Do not set any delay lengths larger than the VSYNC period.

### Double-Mode Alignment

When  $DBL = 1$  in both the serializer and deserializer, GMSL automatically keeps the pixels in order. Use double-mode alignment when  $DBL = 1$  in the serializer and  $DBL = 0$  (or is not supported) in the deserializer. Two different methods are available for double-mode alignment.

### External High/Low Signal

To use an external alignment signal, set  $EN\_HI\_LO = 1$ ,  $DBL\_ALIGN\_TO = 000$ , and select which input  $DIN\_pin$  to use by setting the  $CROSSBAR\_HI\_LO$  bits. The external signal designates whether the clocked word is

the high or low word (e.g., for pixels [1H, 1L, 2H, 2L...] the high/low signal would be [1, 0, 1, 0...]).

### Align from HS or DE

To align from a sync signal, set the  $DBL\_ALIGN\_TO$  to select the input signal. When using this mode, ensure that the signal used for alignment uses the same value for both the high and low word (e.g., for pixels [1H, 1L, 2H, 2L...], aligning on DE requires values of [DE1, DE1, DE2, DE2...]).

### Control-Channel Interfaces

#### I<sup>2</sup>C

Set  $I2CSEL = 1$  to configure the control channel for I<sup>2</sup>C to I<sup>2</sup>C. In this mode, the control channel forwards I<sup>2</sup>C commands from the microcontroller side to the other side of the GMSL link. The remote device acts as an I<sup>2</sup>C master to the other peripherals connected to the remote-side device. I<sup>2</sup>C-to-I<sup>2</sup>C mode uses clock stretching to hold the microcontroller until the data and an acknowledge or not acknowledge have been sent across the link.

#### I<sup>2</sup>C Bit Rate

The I<sup>2</sup>C interface accepts bit rates from 9.6kbps to 1Mbps. The local I<sup>2</sup>C rate is set by the microcontroller. The remote I<sup>2</sup>C rate is set by the remote device. By default, the control channel is set up for a 400kbps I<sup>2</sup>C bit rate. Program the  $I2C\_MSTBT$  and  $SLV\_SH$  bits (register 0x0D) to match the desired microcontroller I<sup>2</sup>C rate.

**Table 8. Timing-Generator Parameter Restrictions**

SIGNAL	SIZE (BITS)	MIN VALUE (HEX)	MAXIMUM VALUE RESTRICTION (HEX)
VS_HIGH	24	1	$VS\_HIGH + VS\_LOW < 0xFFFFFFFF$
VS_LOW	24	1	$VS\_HIGH + VS\_LOW < 0xFFFFFFFF$
VS_DLY	24	0	$VS\_DLY < VS\_HIGH + VS\_LOW$
HS_HIGH	16	1	$(HS\_HIGH + HS\_LOW) \times HS\_CNT < VS\_HIGH + VS\_LOW$
HS_LOW	16	1	$(HS\_HIGH + HS\_LOW) \times HS\_CNT < VS\_HIGH + VS\_LOW$
HS_CNT	16	1	$(HS\_HIGH + HS\_LOW) \times HS\_CNT < VS\_HIGH + VS\_LOW$
HS_DLY	24	0	$HS\_DLY < VS\_HIGH + VS\_LOW$
DE_HIGH	16	1	$(DE\_HIGH + DE\_LOW) \times DE\_CNT < VS\_HIGH + VS\_LOW$
DE_LOW	16	1	$(DE\_HIGH + DE\_LOW) \times DE\_CNT < VS\_HIGH + VS\_LOW$
DE_CNT	16	1	$(DE\_HIGH + DE\_LOW) \times DE\_CNT < VS\_HIGH + VS\_LOW$
DE_DLY	24	0	$DE\_DLY < VS\_HIGH + VS\_LOW$

### Software Programming of Device Addresses

The serializer and deserializer have programmable device addresses. This allows multiple GMSL devices, along with I<sup>2</sup>C peripherals, to coexist on the same control channel. The serializer device address is in register 0x00 of each device, while the deserializer device address is in register 0x01 of each device. To change a device address, first write to the device whose address changes (register 0x00 of the serializer for serializer device address change, or register 0x01 of the deserializer for deserializer device address change). Then, write the same address into the corresponding register on the other device (register 0x00 of the deserializer for serializer device address change, or register 0x01 of the serializer for deserializer device address change).

### I<sup>2</sup>C Address Translation

The device supports I<sup>2</sup>C address translation for up to two device addresses. Use address translation to assign unique device addresses to peripherals with limited I<sup>2</sup>C addresses. Source addresses (address to translate from) are stored in registers 0x09 and 0x0B. Destination addresses (address to translate to) are stored in registers 0x0A and 0x0C.

### Configuration Blocking

The device can block changes to its registers. Set CFGBLOCK to make all registers read-only. Once set, the registers remain blocked until the supplies are removed or until PWDNB is low.

### Cascaded/Parallel Devices

GMSL supports both cascaded and parallel devices connected through I<sup>2</sup>C. When cascading or using parallel links, all I<sup>2</sup>C commands are forwarded to all links. Each link attempts to hold the control channel until it receives an acknowledge/not acknowledge from the remote-side device. It is important to keep the control channel active between links to prevent timeout. If a link is unused, keep the control channel clear by turning on the configuration link, disconnecting the I<sup>2</sup>C lines, or powering down the unused device.

### Dual $\mu$ C Control

Most systems use a single microcontroller; however  $\mu$ Cs can reside on each side simultaneously and trade off in running the control channel. Contention occurs if both  $\mu$ Cs attempt to use the control channel at the same time. It is up to the user to prevent this contention by implementing a higher level protocol. In addition, the control channel does not provide arbitration between I<sup>2</sup>C masters on both sides of the link. An acknowledge frame is not generated when communication fails due to contention. If communication across the serial link is not required, the  $\mu$ Cs can disable the forward and reverse control channel using the FWCCEN and REVCCEN bits (0x04, D[1:0]) in the serializer/deserializer. Communication across the serial link is stopped and contention between  $\mu$ Cs cannot occur.

### UART

Set I2CSEL = 0 to configure the control channel for UART or UART-to-I<sup>2</sup>C mode. In this mode, the control channel forwards UART commands from the microcontroller side to the other side of the GMSL link. When INTTYPE = 00, the remote device acts as an I<sup>2</sup>C master to the other peripherals connected to the remote-side device. UART-to-I<sup>2</sup>C mode does not support devices that use clock stretching.

### Base Mode

In base mode, UART packets control the serializer, deserializer, and attached peripherals.

### UART Timing

In base mode, the UART idles high (through a pullup resistor). Each GMSL UART byte consists of a START bit, 8 data bits, an even-parity bit, and a STOP bit (Figure 21). Keep the idle time between bytes of the same UART packet to less than 4 bit times. The GMSL-UART protocol is listed in Figure 22. A write packet consists of a SYNC byte (Figure 23), device address byte, starting register address byte, number of bytes to write, and the data bytes. The slave device responds with an ACK byte (Figure 24) if the write was successful. A read packet consists of a SYNC byte, device address byte, starting register address byte, and number of bytes to read. The slave device responds with an ACK byte, and the read data bytes.

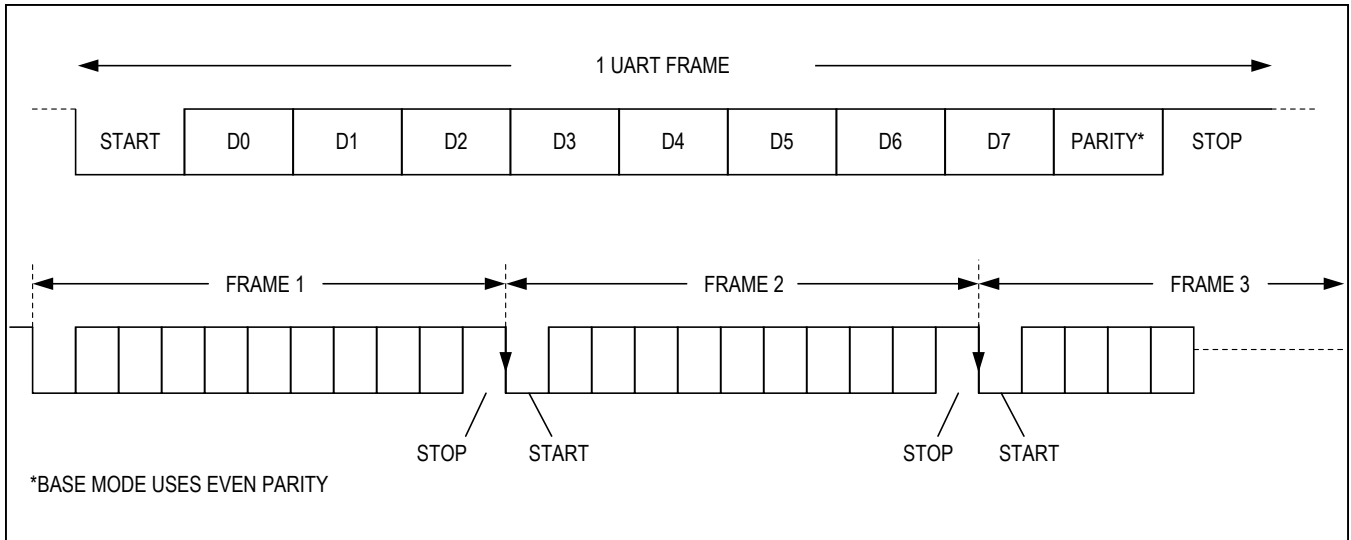

Figure 21. GMSL-UART Data Format for Base Mode

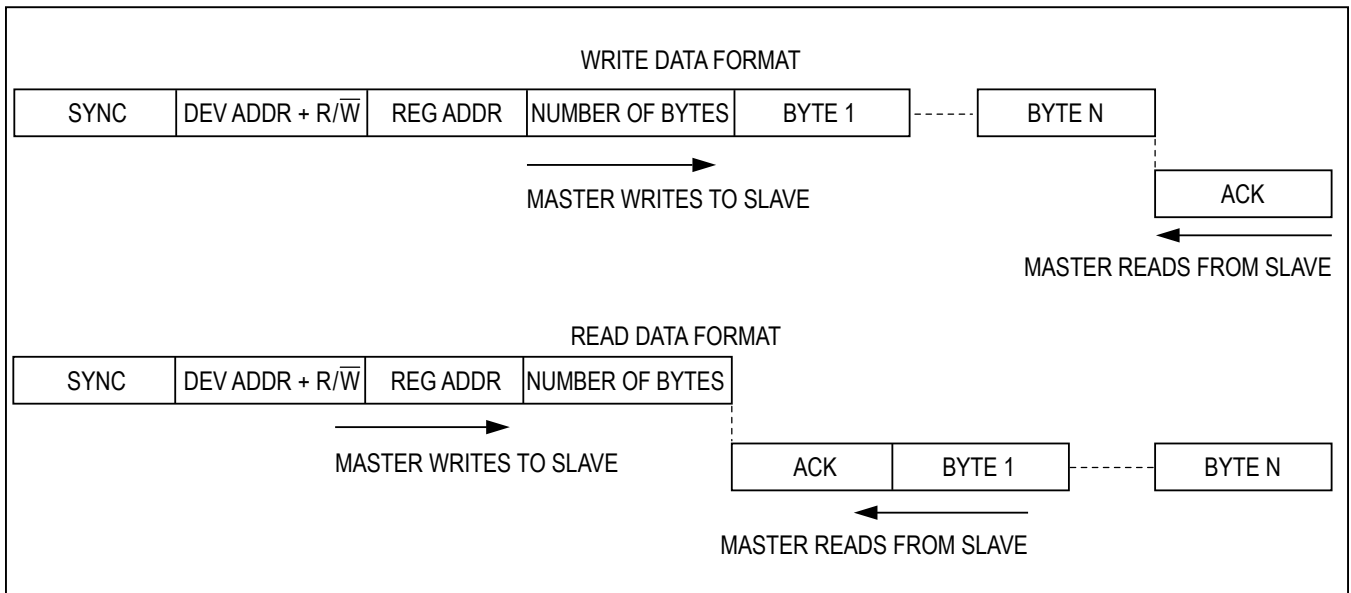

Figure 22. GMSL-UART Protocol for Base Mode

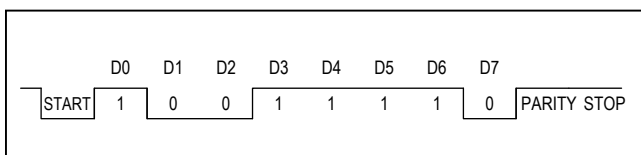

Figure 23. SYNC Byte (0x79)

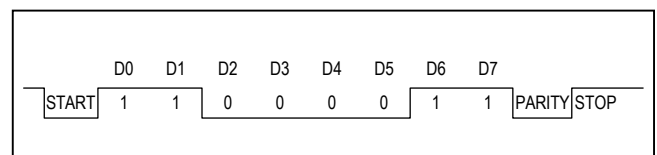

Figure 24. ACK Byte (0xC3)

**UART-to-I<sup>2</sup>C Conversion**

When using the UART control channel, the remote-side device can communicate to I<sup>2</sup>C peripherals through UART-to-I<sup>2</sup>C conversion. Set the INTTYPE bits in the remote-side device to 00 to activate UART-to-I<sup>2</sup>C conversion. The converted I<sup>2</sup>C bit rate is the same as the incoming UART bit rate. I<sup>2</sup>C peripherals must not use clock stretching in order to be compatible with UART-to-I<sup>2</sup>C conversion.

There are two possible methods the devices use to convert UART to I<sup>2</sup>C. In the first method (I2CMETHOD = 0), the register address is sent with the I<sup>2</sup>C communication (Figure 25). For devices that do not use a register address (such as the MAX7324), set I2CMETHOD = 1 and send a dummy byte in place of the register address (Figure 26). In this method, the remote device omits sending the register address.

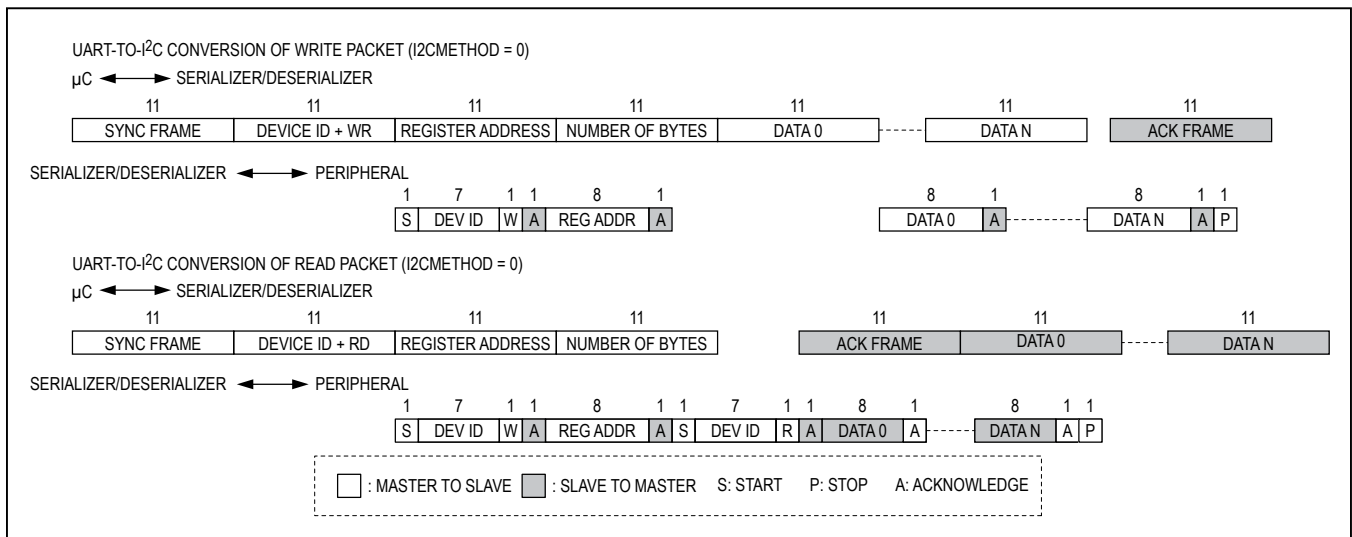

Figure 25. Format Conversion Between GMSL UART and I<sup>2</sup>C with Register Address (I2CMETHOD = 0)

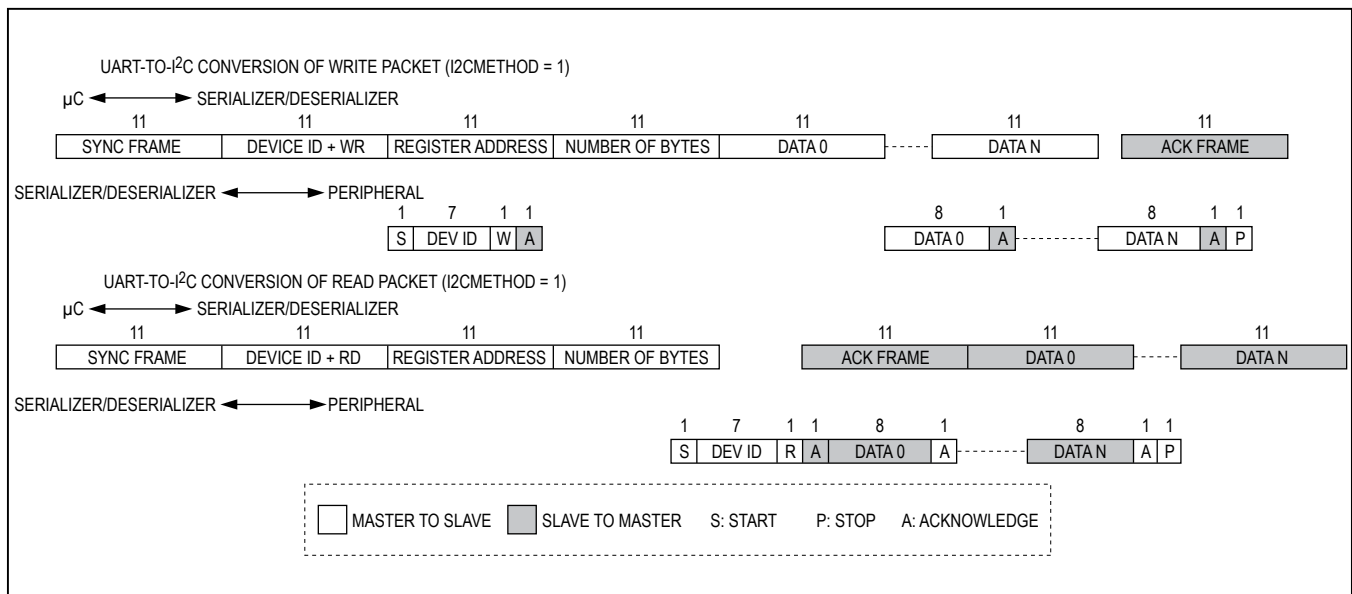

Figure 26. Format Conversion Between GMSL UART and I<sup>2</sup>C with Register Address (I2CMETHOD = 1)

**UART Bypass Mode**

In UART bypass mode, the control channel acts as a full-duplex 9.6kbps to 1Mbps link that forwards UART commands across the serial link without responding to the packets themselves. Set MS high to enter bypass mode (wait 1ms after setting bypass mode if the  $\mu$ C is connected on the deserializer side). Bypass uses bit rates from 9.6kbps to 1Mbps. Do not send a logic-low value longer than 100 $\mu$ s when using the GPI/GPO functionality.

**Device Address**

The serializer/deserializer both have a 7-bit-long slave address stored in registers 0x00 and 0x01. The bit following a 7-bit slave address is the R/W bit, which is low for a write command and high for a read command. The default slave address is 0x80. After startup, a microcontroller can reprogram the slave address as needed.

**Spread Spectrum**

Program the SS bits in the serializer to turn on spread spectrum in the serializer (Table 9). If the deserializer driven by the serializer has programmable spread spectrum, do not enable spread for both at the same time or their interaction cancels benefits. The deserializer tracks the serializer's spread and passes the spread to the deserializer output. Some spread-spectrum ampli-

udes can only be used at lower PCLKIN frequencies (Table 10). When the spread spectrum is turned on or off, the serial link stops for several microseconds and then restarts in order for the deserializer to lose and relock to the new serial-data stream. Changing the spread-spectrum amplitude does not cause a loss of lock.

**Manual Programming of the Spread-Spectrum Divider**

By default, autodetection of the PCLKIN operation range guarantees a spread-spectrum modulation frequency within 20kHz to 40kHz. Additionally, manual configuration of the sawtooth divider (SDIV: 0x03,D[5:0]) allows the user to set a modulation frequency (typically 20kHz) according to the PCLKIN frequency.

**Equation:**

Relation of modulation rate to the PCLKIN frequency:

$$f_M = f_{PCLKIN} / (\text{MOD} \times \text{SDIV})$$

where:

$f_M$  = Modulation frequency

$f_{PCLKIN}$  = PCLKIN frequency

MOD = Modulation coefficient given in Table 11

SDIV = 6-bit SDIV setting, manually programmed by the  $\mu$ C

**Table 9. Output Spread**

SS	SPREAD (%)
000	Power-up default (no spread spectrum)
001	$\pm 0.5\%$ spread spectrum
010	$\pm 1.5\%$ spread spectrum
011	$\pm 2\%$ spread spectrum
100	No spread spectrum
101	$\pm 1\%$ spread spectrum
110	$\pm 3\%$ spread spectrum
111	$\pm 4\%$ spread spectrum

**Table 10. Spread Limitations**

BWS = 0 MODE, PCLKIN FREQUENCY (MHz)	BWS = 1 MODE, PCLKIN FREQUENCY (MHz)	SERIAL LINK BIT RATE (Mbps)	AVAILABLE SPREAD RATES
< 33.3 (DBL = 0)	< 25 (DBL = 0)	< 1000	All rates available
< 66.6 (DBL = 1)	< 50 (DBL = 1)		
33.3 to 58 (DBL = 0)	25 to 43.5 (DBL = 0)	$\geq 1000$	1.5%, 1%, 0.5%
66.6 to 116 (DBL = 1)	50 to 87 (DBL = 1)		

**Table 11. Modulation Coefficients and Maximum SDIV Settings**

BWS	SPREAD-SPECTRUM SETTING (%)	MODULATION COEFFICIENT (DEC)	SDIV UPPER LIMIT (DEC)
1	1	104	40
	0.5	104	63
	3	152	27
	1.5	152	54
	4	204	15
0	2	204	30
	1	80	52
	0.5	80	63
	3	112	37
	1.5	112	63
	4	152	21
	2	152	42

To program the SDIV setting, first look up the modulation coefficient according to the desired bus-width and spread-spectrum settings. Solve the above equation for SDIV using the desired pixel clock and modulation frequencies. If the calculated SDIV value is larger than the maximum allowed SDIV value in [Table 11](#), set SDIV to the maximum value.

**Board Layout**

**Power-Supply Circuits and Bypassing**

The serializer uses an AVDD and DVDD of 1.7V to 1.9V. All inputs and outputs, except for the serial output, derive power from an IOVDD of 1.7V to 3.6V that scales with IOVDD. Proper voltage-supply bypassing is essential for high-frequency circuit stability.

**High-Frequency Signals**

Separate the LVCMOS logic signals and CML/coax high-speed signals to prevent crosstalk. Use a four-layer PCB with separate layers for power, ground, CML/coax, and LVCMOS logic signals. Layout STP-PCB traces close to each other for a 100Ω differential characteristic impedance. The trace dimensions depend on the type of trace used (microstrip or stripline).

**Note:** Two 50Ω PCB traces do not have 100Ω differential impedance when brought close together; the impedance goes down when the traces are brought closer. Use a 50Ω trace for the single-ended output when driving coax. Route the PCB traces for differential CML in parallel to maintain the differential characteristic impedance. Avoid via arrays. Keep PCB traces that make up a differential pair equal in length to avoid skew within the differential pair.

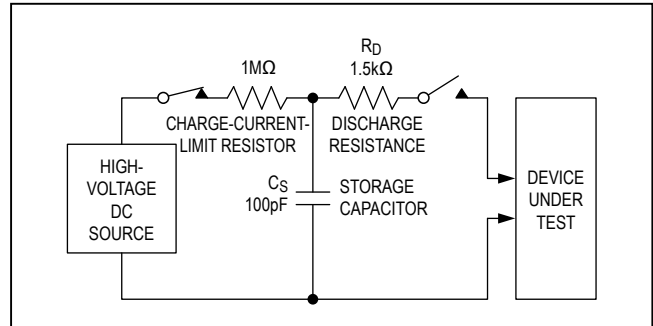

Figure 27. Human Body Model ESD Test Circuit

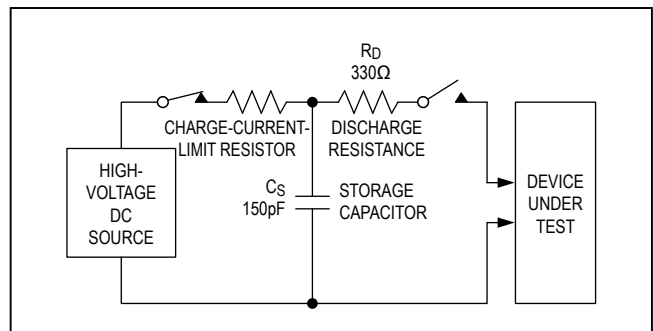

Figure 28. IEC 61000-4-2 Contact Discharge ESD Test Circuit

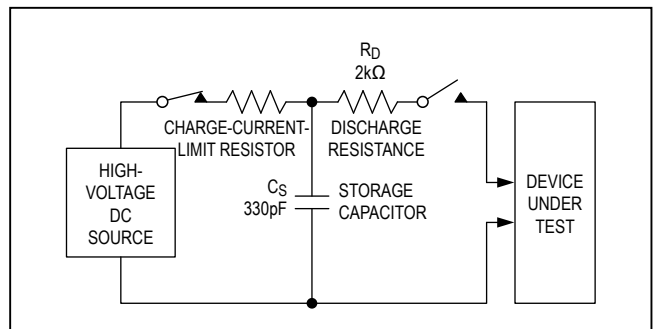

Figure 29. ISO 10605 Contact Discharge ESD Test Circuit

**ESD Protection**

ESD tolerance is rated for Human Body Model, IEC 61000-4-2, and ISO 10605. The ISO 10605 and IEC 61000-4-2 standards specify ESD tolerance for electronic systems. The serial outputs are rated for ISO 10605 ESD protection and IEC 61000-4-2 ESD protection. All pins are tested for the Human Body Model. The Human Body Model discharge components are CS = 100pF and RD = 1.5kΩ (Figure 27). The IEC 61000-4-2 discharge components are CS = 150pF and RD = 330Ω (Figure 28). The ISO 10605 discharge components are CS = 330pF and RD = 2kΩ (Figure 29).

**Compatibility with Other GMSL Devices**

The device is designed to pair with the MAX96705–MAX96711 family of devices, but interoperates with any GMSL device. See [Table 12](#) for operating limitations.

**Device Configuration and Component Selection**

**Internal Input Pulldowns**

The control and configuration inputs (except three-level inputs) include a pulldown resistor to GND; external pull-down resistors are not needed.

**Three-Level Configuration Inputs**

CONF1 and CONF0 are three-level inputs that control the serial interface configuration and power-up defaults ([Table 13](#)). Connect CONF1 or CONF0 to IOVDD to set a high level, to GND to set a low level, or open to set a mid level. For digital control, use three-state logic to drive the three-level logic inputs. CONF pin values are latched at power-up or resuming from power-down mode.

**Multifunction Inputs**

The device has several inputs/outputs that serve multiple functions. GPO/HIM functions as the GPO output, and as a configuration pin. On power-up, or when reverting from a power-down state, the pins act as the HIM input. After latching the input state, the pin becomes the GPO output. Connect a configuration input through a 30kΩ resistor to IOVDD to set a high level. Leave the configuration input open to set a low level.

In addition, several multifunction pins are controlled by the LCCEN input. When LCCEN = 1, the local control channel (RX/SDA, TX/SCL) is active, and the GPIO1/ BWS and MS/HVEN pins behave as GPIO1 and the MS input respectively. When LCCEN = 0, the local control channel is disabled, and these pins operate as their alternate function (DBL, BWS, HVEN inputs).

**Table 12. Feature Compatibility**

SERIALIZER FEATURE	GMSL DESERIALIZER
HSYNC/VSYNC Encoding	If feature not supported in the deserializer, turn off in the serializer.
I <sup>2</sup> C to I <sup>2</sup> C	If feature not supported in the deserializer, use UART to I <sup>2</sup> C or UART to UART.
Packet Control Channel	If feature not supported in the deserializer, use legacy control channel.
CRC Error Detection	If feature not supported in the deserializer, turn off in the serializer.
Double Input	If feature not supported in the deserializer, data is output as a single word at half the input frequency. Use crossbar switch to correct input mapping.
Coax	If feature not supported in the deserializer, connect unused serial input through 200nF and 50Ω in series to AVDD, and set the reverse control-channel amplitude to 100mV.
I <sup>2</sup> S Encoding	If supported in the deserializer, disable I <sup>2</sup> S in the deserializer.
High-Bandwidth Mode	If feature not supported in the deserializer, turn off in the serializer.
High-Immunity Mode	If feature not supported in the deserializer, turn off in the serializer.
Low-Speed Mode	If supported in the deserializer, set DRS to 0 in the deserializer.

**Table 13. Three-Level Configuration Input Map**

CONF1	CONF0	CXTP (OUT+/OUT- OUTPUT TYPE)	ES (PCLKIN LATCH EDGE)	I <sup>2</sup> CSEL (CONTROL-CHANNEL TYPE)
Low	Low	1 (coax)	1 (falling)	1 (I <sup>2</sup> C o I <sup>2</sup> C)
Low	Mid	1 (coax)	1 (falling)	0 (UART to I <sup>2</sup> C/UART)
Low	High	1 (coax)	0 (rising)	1 (I <sup>2</sup> C to I <sup>2</sup> C)
Mid	Low	1 (coax)	0 (rising)	0 (UART to I <sup>2</sup> C/UART)
Mid	Mid	0 (STP)	1 (falling)	1 (I <sup>2</sup> C to I <sup>2</sup> C)
Mid	High	0 (STP)	1 (falling)	0 (UART to I <sup>2</sup> C/UART)
High	Low	0 (STP)	0 (rising)	1 (I <sup>2</sup> C to I <sup>2</sup> C)
High	Mid	0 (STP)	0 (rising)	0 (UART to I <sup>2</sup> C/UART)
High	High	Do not use	Do not use	Do not use

**Table 14. Suggested Connectors and Cables for GMSL**

VENDOR	CONNECTOR	CABLE	TYPE
Rosenberger	59S2AX-400A5-Y	Dacar 302	Coax
Rosenberger	D4S10A-40ML5-Z	Dacar 538	STP
Nissei	GT11L-2S	F-2WME AWG28	STP
JAE	MX38-FF	A-BW-Lxxxxx	STP

### I<sup>2</sup>C/UART Pullup Resistors

The I<sup>2</sup>C and UART open-drain lines require a pullup resistor to provide a logic-high level. There are tradeoffs between power dissipation and speed, and a compromise may be required when choosing pullup resistor values. Every device connected to the bus introduces some capacitance even when the device is not in operation. I<sup>2</sup>C specifies 300ns rise times (30% to 70%) for fast mode, which is defined for data rates up to 400kbps (see the *I<sup>2</sup>C/UART Port Timing* section in the [AC Electrical Characteristics](#) table for details). To meet the fast-mode rise-time requirement, choose the pullup resistors so that rise time  $t_R = 0.85 \times R_{PULLUP} \times C_{BUS} < 300\text{ns}$ . The waveforms are not recognized if the transition time becomes too slow. GMSL supports I<sup>2</sup>C/UART rates up to 1Mbps (UART-to-I<sup>2</sup>C mode) and 400kbps (I<sup>2</sup>C-to-I<sup>2</sup>C mode).

### AC-Coupling Capacitors

Voltage droop and the digital-sum variation (DSV) of transmitted symbols cause signal transitions to start from different voltage levels. Because the transition time is fixed, starting the signal transition from different voltage levels causes timing jitter. The time constant for an AC-coupled link needs to be chosen to reduce droop and jitter to an acceptable level. The RC network for an AC-coupled link consists of the CML/coax receiver termination resistor ( $R_{TR}$ ), the CML/coax-driver termination resistor ( $R_{TD}$ ), and the series AC-coupling capacitors (C). The RC time constant for four equal-value series capacitors is  $(C \times (R_{TD} + R_{TR}))/4$ .  $R_{TD}$  and  $R_{TR}$  are required to match the transmission-line impedance (usually 100Ω differential, 50Ω single-ended). This leaves the capacitor selection to change the system time constant. Use 0.2μF or larger high-frequency, surface-mount ceramic capacitors with sufficient voltage rating to withstand a short to battery, to pass the lower speed reverse control-channel signal. Use capacitors with a case size less than 3.2mm x 1.6mm to have lower-parasitic effects to the high-speed signal.

### Cables and Connectors

Interconnect for CML typically has a differential impedance of 100Ω. Use cables and connectors that have matched differential impedance to minimize impedance discontinuities. Coax cables typically have a characteristic impedance of 50Ω; contact the factory for 75Ω operation). [Table 14](#) lists the suggested cables and connectors used in the GMSL link.

### PRBS

The serializer includes a PRBS pattern generator that works with bit-error verification in the deserializer. To run the PRBS test, set PRBSEN = 1 (0x04, D5) in the deserializer, then in the serializer. To exit the PRBS test, set PRBSEN = 0 (0x04, D5) in the serializer. The deserializer automatically ends PRBS checking and sets the PRBS\_OK bit high. During PRBS mode, the forward control channel is not available except to exit PRBS mode if autoacknowledge is enabled in the deserializer; otherwise, the remote control channel is not available at all.

To run the PRBS with a 3Gbps SerDes, or when HIBW = 1, first set the PRBS\_TYPE bit = 0 in the MAX967XX. Then set PRBSEN = 1 (0x04, D5) in the serializer and then in the deserializer. To exit the PRBS test, set PRBSEN = 0 (0x04, D5) in the deserializer, then in the serializer.

During PRBS test, ERRB function changes to reflect PRBS errors only. ERRB goes low when any PRBS errors occur. ERRB goes high when the PRBS error counter is reset when PRBS\_ERR is read. Normal ERRB function resumes when exiting the PRBS test.

### GPI/GPO

GPO on the serializer follows GPI transitions on the deserializer. By default, the GPI-to-GPO delay is 0.35ms (max). Keep the time between GPI transitions to a minimum 0.35ms. GPI\_IN the deserializer stores the GPI input state. GPO is low after power-up. The μC can set GPO by writing to the SET\_GPO register bit. Do not send a logic-low value on the deserializer RX/SDA input (UART mode) longer than 100μs in either base or bypass mode to ensure proper GPO/GPI functionality.



### Fast Detection of Loss-of-Lock

A measure of link quality is the recovery time from loss-of-synchronization. The host can be quickly notified of loss-of-lock by connecting the deserializer's LOCK output to the GPI input (when PKTCC\_EN = 0). If other sources use the GPI input, such as a touch-screen controller, the  $\mu$ C can implement a routine to distinguish between interrupts from loss-of-sync and normal interrupts. Reverse control-channel communication does not require an active forward link to operate and accurately tracks the LOCK status of the GMSL link. LOCK asserts for video link only and not for the configuration link.

### Providing a Frame Sync (Camera Applications)

The GPI and GPO provide a simple solution for camera applications that require a frame-sync signal from the ECU (e.g., surround-view systems). Connect the ECU frame-sync signal to the GPI input and connect the GPO output to the camera frame-sync input. GPI/GPO have a typical delay of 275 $\mu$ s in legacy mode and 21 $\mu$ s in packet mode (with 5-bit CRC). Skew between multiple GPI/GPO channels is 115 $\mu$ s (max) in legacy mode and 21 $\mu$ s (max) in packet mode. If a lower skew signal is required in legacy mode, connect the camera's frame-sync input to one of the serializer's GPIOs and use an I<sup>2</sup>C broadcast-write command to change the GPIO output state. This has a maximum skew of 1.5 $\mu$ s, independent from the used I<sup>2</sup>C bit rate. In packet-based control-channel mode, set GPI\_COMP\_EN = 1 in both the serializer and deserializer to turn on GPI/GPO compensation. This reduces the device-to-device skew to 0.35 $\mu$ s.

### Entering/Exiting Sleep Mode

The procedure for entering and exiting sleep mode depends on the location of the microcontroller, and the type of control-channel interface used. If wake up from a remote (deserializer) side microcontroller is not needed or desired, set the DIS\_RWAKE bit = 1 to shut down remote wake-up for further power savings.

### Legacy Control Channel:

To enter sleep mode, set SLEEP = 1. The device sleeps after 8ms. To wake up the device, send an arbitrary control-channel command to the serializer (the serializer does not send an acknowledge), wait for 5ms for the chip to power up and then set SLEEP = 0 to make the wake-up permanent.

### Packet-Based Control Channel:

- When  $\mu$ C is on the deserializer side, set SLEEP = 1 in serializer. Next set REVCCEN = 0 in the deserializer to stop reverse-control transmission to the serializer. The device sleeps after 8ms.

To wake up the serializer, first set REVCCEN = 1, wait 8ms for the device to wake up and then set SLEEP = 0 to exit sleep mode permanently.

- When  $\mu$ C is on the serializer side, first set SLEEP = 1 in the deserializer. If the deserializer must remain awake, switch to legacy control-channel mode. Next, set SLEEP = 1 in the serializer. The device sleeps after 8ms.

To wake up the device, send an arbitrary control-channel command to the serializer (the serializer does not send an acknowledge). Wait for 5ms for the chip to power up and then set SLEEP = 0 to make the wake-up permanent. The deserializer wakes up and clears its SLEEP bit when serialization is enabled and it locks to the serializer.

Typical Application Circuits

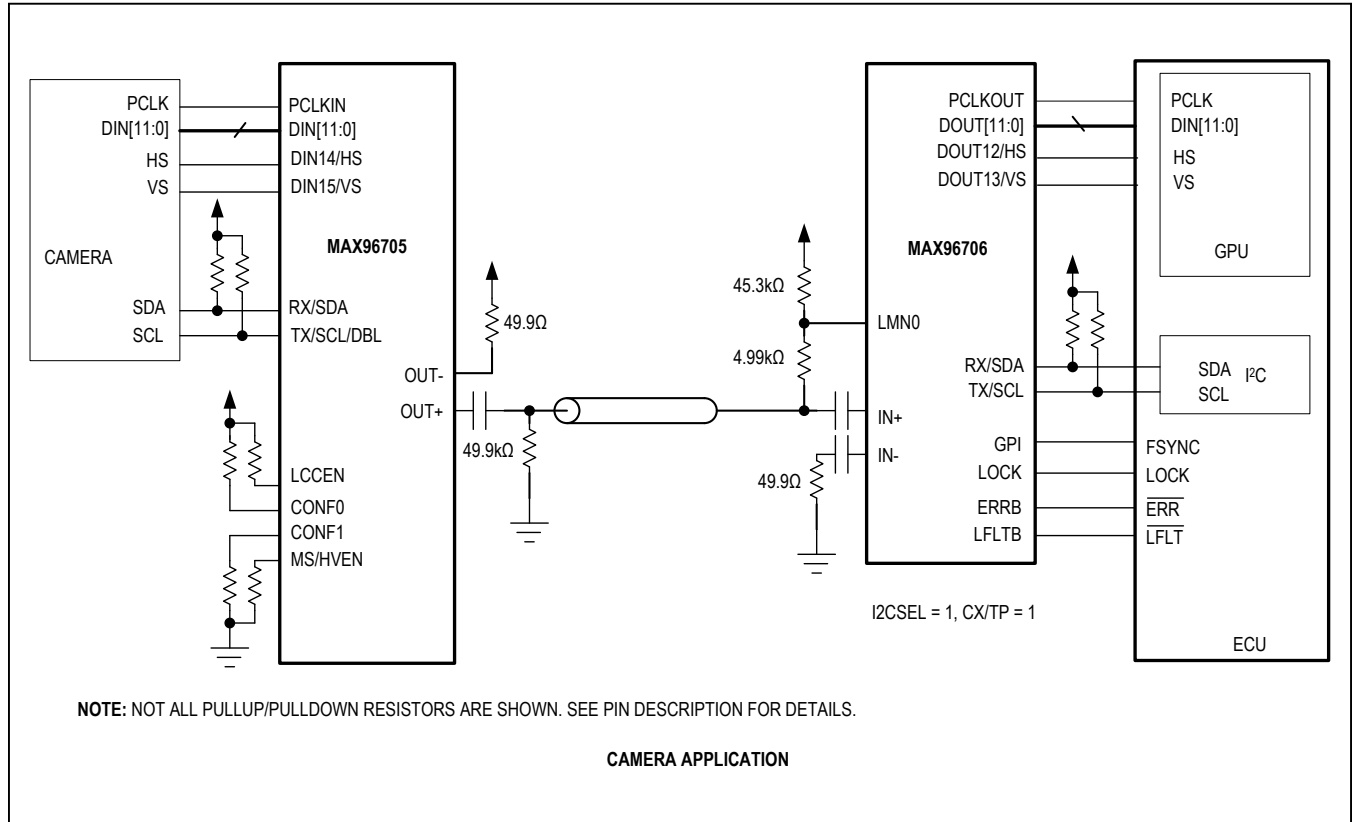

Ordering Information

PART NUMBER	TEMP RANGE	PIN-PACKAGE
MAX96705GTJ/V+	-40°C to +115°C	32 TQFN-EP*

V denotes an automotive qualified product.  
 +Denotes a lead(Pb)-free/RoHS-compliant package.  
 \*EP = Exposed pad.

## Revision History

REVISION NUMBER	REVISION DATE	DESCRIPTION	PAGES CHANGED
0	12/15	Initial release	—

For pricing, delivery, and ordering information, please contact Maxim Direct at 1-888-629-4642, or visit Maxim Integrated's website at [www.maximintegrated.com](http://www.maximintegrated.com).

*Maxim Integrated cannot assume responsibility for use of any circuitry other than circuitry entirely embodied in a Maxim Integrated product. No circuit patent licenses are implied. Maxim Integrated reserves the right to change the circuitry and specifications without notice at any time. The parametric values (min and max limits) shown in the Electrical Characteristics table are guaranteed. Other parametric values quoted in this data sheet are provided for guidance.*

Компания «Life Electronics» занимается поставками электронных компонентов импортного и отечественного производства от производителей и со складов крупных дистрибьюторов Европы, Америки и Азии.

С конца 2013 года компания активно расширяет линейку поставок компонентов по направлению коаксиальный кабель, кварцевые генераторы и конденсаторы (керамические, пленочные, электролитические), за счёт заключения дистрибьюторских договоров

Мы предлагаем:

- Конкурентоспособные цены и скидки постоянным клиентам.
- Специальные условия для постоянных клиентов.
- Подбор аналогов.
- Поставку компонентов в любых объемах, удовлетворяющих вашим потребностям.
- Приемлемые сроки поставки, возможна ускоренная поставка.
- Доставку товара в любую точку России и стран СНГ.
- Комплексную поставку.
- Работу по проектам и поставку образцов.
- Формирование склада под заказчика.
- Сертификаты соответствия на поставляемую продукцию (по желанию клиента).
- Тестирование поставляемой продукции.
- Поставку компонентов, требующих военную и космическую приемку.
- Входной контроль качества.
- Наличие сертификата ISO.

В составе нашей компании организован Конструкторский отдел, призванный помогать разработчикам, и инженерам.

Конструкторский отдел помогает осуществить:

- Регистрацию проекта у производителя компонентов.
- Техническую поддержку проекта.
- Защиту от снятия компонента с производства.
- Оценку стоимости проекта по компонентам.
- Изготовление тестовой платы монтаж и пусконаладочные работы.



Тел: +7 (812) 336 43 04 (многоканальный)  
Email: [org@lifeelectronics.ru](mailto:org@lifeelectronics.ru)