

## Product Brief

# SMT-Ready E-Band Radio Frontend – Reference Design

## 3 Gbit/s FDD Radio with Infineon E-band transceiver chipsets BGT70 and BGT80

Broadband wireless backhaul technologies have become a key element of cost-effective high speed wireless networks. With the explosive growth in wireless data traffic, telecom companies need to deploy multi-gigabit backhaul links. With 10 GHz bandwidth available in the lightly licensed E-Band spectrum and advances in semiconductor technology, E-Band links have gained momentum. Infineon's mmWave Transceivers BGT70/BGT80 enable such high-performance Gbps links. With its advanced SiGe:C technology, these transceivers are highly integrated and housed in eWLB packages thus offering customers performance, price and time to market advantages.

The RF frontend reference design (Figure 1) features two E-band MMIC transceivers mounted on a compact motherboard. Separate hardware versions for low-band (71–76 GHz) and high-band (81–86 GHz) modes of operation are available. The RF module is designed on RO3003 PCB and the transitions (Differential to Single Ended, Differential to Waveguide) have been optimized to achieve minimum losses on board. In order to cover longer distances with complex modulation schemes (128-QAM), two packaged GaAs power amplifiers (PA) are used at the output of BGT70/BGT80. A packaged low noise amplifier (LNA) has been used at the receiver input terminals of the BGT70/80 to improve the overall sensitivity of the system.

The motherboard has analog differential I-Q interfaces, baseband filters, variable gain amplifiers (VGA) at the transmit and receive sections, an Infineon XMC4200 32-bit ARM® Cortex™-M4 microcontroller, control circuitry for de-biasing the power amplifier and voltage regulators for the power supply.

A diplexer is mounted directly on transceiver mechanics to achieve a small form factor of the final assembly.

**Figure 1 RF Frontend Reference Design**

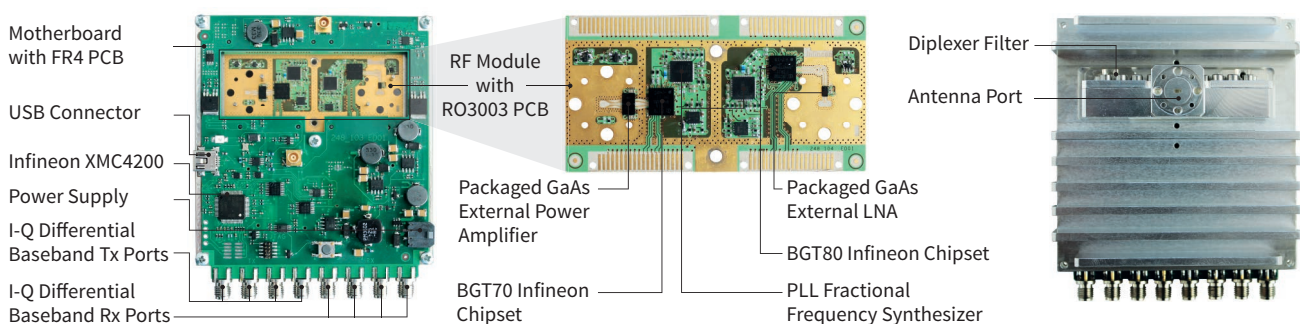

### Reference Design Features

- +12 dBm of output power with 64-QAM
- 3 Gbit/s full-duplex data rate
- Support 1 GHz channel spacing with configurable modulation from QPSK to 128-QAM
- FDD mode of operation
- BGT70/BGT80 based design with Rx AGC loop, Tx-Rx baseband filters and additional power amplifier to achieve +21 dBm  $P_{sat}$  at antenna port
- Separate hardware versions for low-band and high-band modes of operation
- +12 V DC power supply

# SMT-Ready E-Band Radio Frontend – Reference Design

Figure 2 Block Diagram of 70–80 GHz FDD Radio Frontend

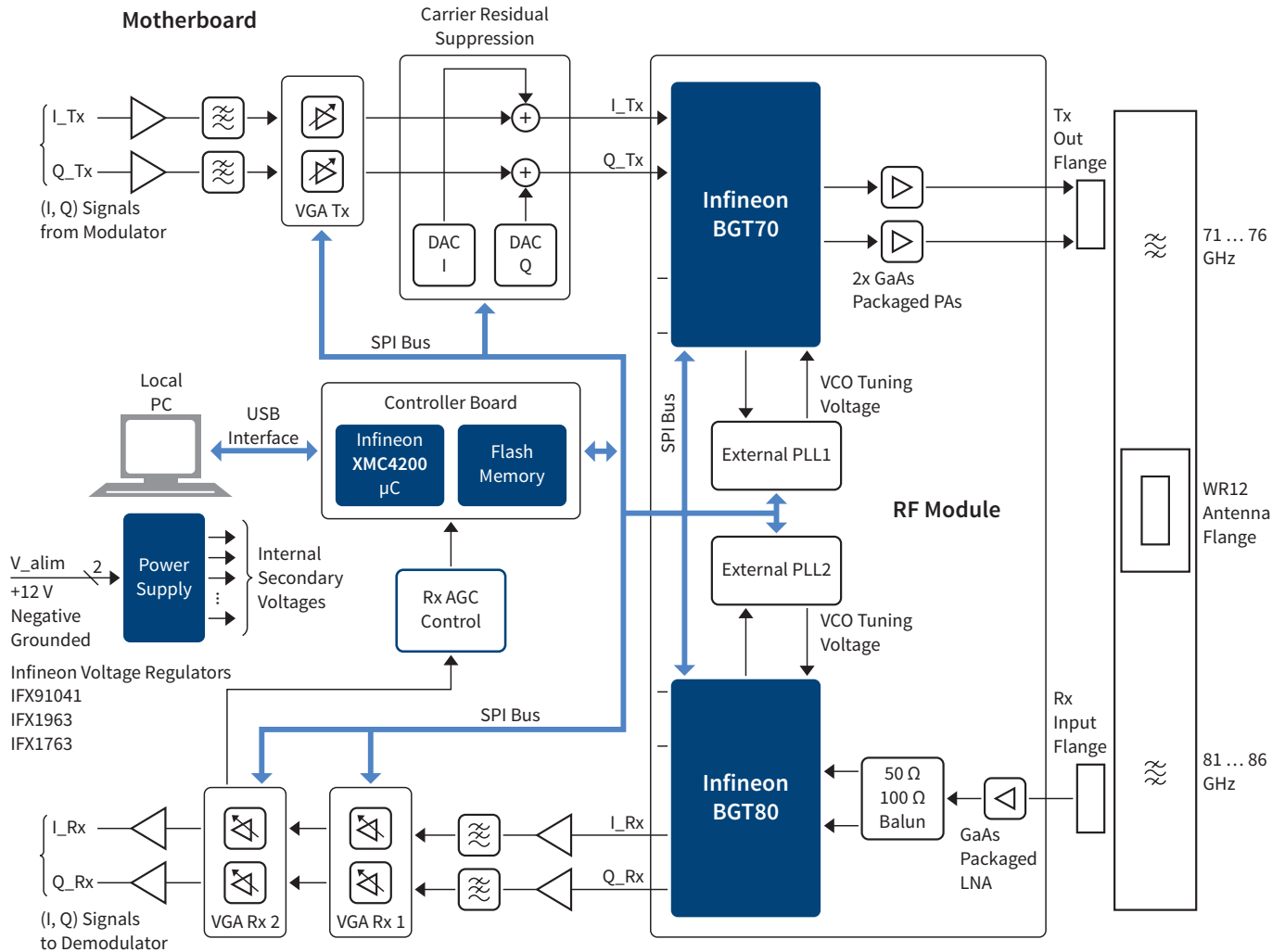

**Main Technical Parameters**

- Operating frequency ranges: 71 ... 76 GHz/81 ... 86 GHz
- Supported channel bandwidth: 50 MHz ... 1 GHz
- Output saturation power at antenna port:  $P_{sat} = +21$  dBm typical
- Transmitter output power at antenna port:  $P_{Tx} = +12$  dBm typical @ 64-QAM modulation
- Tx dynamic range of power setting: 19 dB
- Tx OIP3 at antenna port: +26 dBm typical
- Tx phase noise: -80 dBc/Hz typical @ 100 kHz offset
- Rx noise figure 70 GHz band: 7 dB typical at antenna port
- Rx noise figure 80 GHz band: 8 dB typical at antenna port
- Rx phase noise: -80 dBc/Hz typical @ 100 kHz offset
- Diplexer insertion loss: < 0.7 dB
- Diplexer return loss at antenna port: > 15 dB
- Power consumption (BGT Tx/BGT Rx/GaAs PA): 1.5/1.2/4.8 W
- Rx sensitivity: -60dBm typical @ 64-QAM modulation

# SMT-Ready E-Band Radio Frontend – Reference Design

Figure 3 System Reference Design

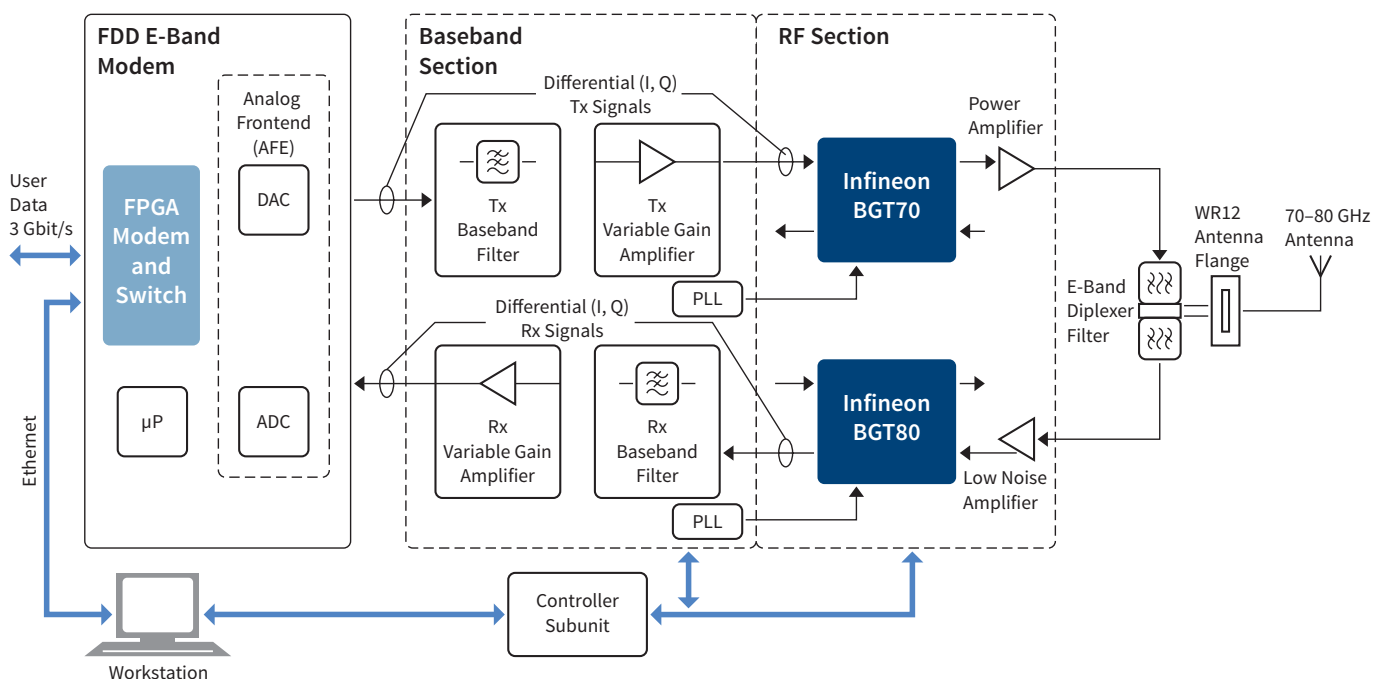

The current System Reference Design (Figure 3) uses the mmWave Modem module (ESM-5008) from Escape Communications to achieve over 3 Gbps links. ESM-5008 is high data rate modem that meets the ETSI channel spacing of 500 MHz with configurable modulation from QPSK to 256QAM. An external power amplifier and low noise amplifier on the design helps to achieve very good link margin. The modem board has a powerful micro-processor, Power-over-Ethernet (PoE) and analog I/Q baseband interfaces which drive BGT70 and BGT80 in the current design.

In addition to the state-of-the-art performances of BGT70/80 and ESM-5008, the system reference design provide customers with a reliable solution which has small form factor, high degree of flexibility, low cost and accelerates product time to market. A BGT70/80-based system architecture can be applied to either FDD or TDD modes of operation, in licensed and unlicensed bands according to different customer requirements.

## Applications

- LTE, WiMAX and HSDPA+ wireless backhaul in E-Band
- Private networks and campus connectivity
- Fiber extensions and replacements
- High definition video surveillance and monitoring
- Public safety applications
- Triple-play (voice, data and video) transmission
- Critical infrastructure protection

# SMT-Ready E-Band Radio Frontend – Reference Design

The following block diagram (Figure 4) refers to ESM-5008 high-speed E-band modem provided by Escape Communications which has been successfully interfaced with Infineon 70–80 GHz Radio Frontend to achieve over 3 Gbps links.

Figure 4 Escape Communications Modem

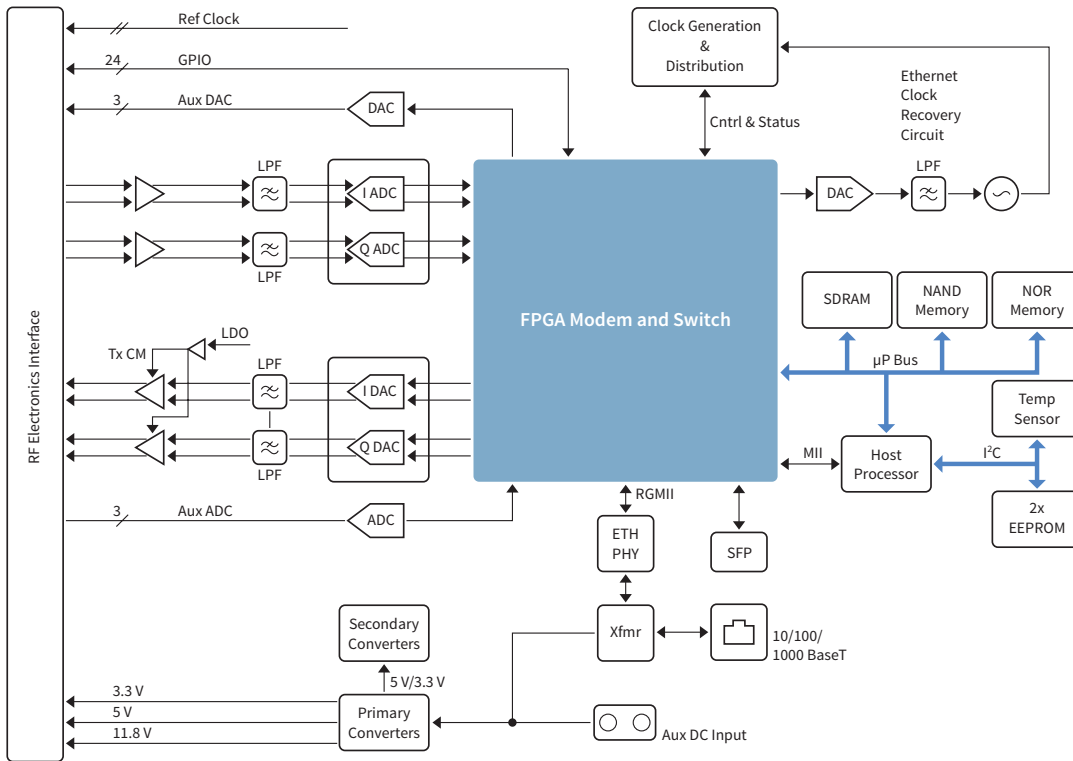

## ESM-5008 E-Band Modem – Main Technical Characteristics

- All-digital Gigabit Ethernet (GigE) modem
- FDD mode of operation
- Meets ETSI channel spacing
- Configurable modulation from QPSK to 256-QAM with Adaptive Coding Modulation (ACM)
- > 3 Gbit/s full-duplex data rate
- Configurable forward error correction
- Supports IEEE 1588V2 and Sync-E
- Layer 2 GigE switch supporting In-band management, flow control, support of Jumbo frames, and QoS
- Http web Graphical User Interface
- 802.11at Power over Ethernet (PoE+)
- 6.26 inch x 6.26 inch board designed for outdoor environment use



Published by  
Infineon Technologies AG  
85579 Neuburg, Germany

© 2015 Infineon Technologies AG.  
All Rights Reserved.

Visit us:  
[www.infineon.com](http://www.infineon.com)

### Please note!

THIS DOCUMENT IS FOR INFORMATION PURPOSES ONLY AND ANY INFORMATION GIVEN HEREIN SHALL IN NO EVENT BE REGARDED AS A WARRANTY, GUARANTEE OR DESCRIPTION OF ANY FUNCTIONALITY, CONDITIONS AND/OR QUALITY OF OUR PRODUCTS OR ANY SUITABILITY FOR A PARTICULAR PURPOSE. WITH REGARD TO THE TECHNICAL SPECIFICATIONS OF OUR PRODUCTS, WE KINDLY ASK YOU TO REFER TO THE RELEVANT PRODUCT DATA SHEETS PROVIDED BY US. OUR CUSTOMERS AND THEIR TECHNICAL DEPARTMENTS ARE REQUIRED TO EVALUATE THE SUITABILITY OF OUR PRODUCTS FOR THE INTENDED APPLICATION.

WE RESERVE THE RIGHT TO CHANGE THIS DOCUMENT AND/OR THE INFORMATION GIVEN HEREIN AT ANY TIME.

### Additional information

For further information on technologies, our products, the application of our products, delivery terms and conditions and/or prices please contact your nearest Infineon Technologies office ([www.infineon.com](http://www.infineon.com)).

### Warnings

Due to technical requirements, our products may contain dangerous substances. For information on the types in question please contact your nearest Infineon Technologies office.

Except as otherwise explicitly approved by us in a written document signed by authorized representatives of Infineon Technologies, our products may not be used in any life endangering applications, including but not limited to medical, nuclear, military, life critical or any other applications where a failure of the product or any consequences of the use thereof can result in personal injury.

Order Number: B132-I0128-V1-7600-EU-EC-P  
Date: 04 / 2015

Компания «Life Electronics» занимается поставками электронных компонентов импортного и отечественного производства от производителей и со складов крупных дистрибьюторов Европы, Америки и Азии.

С конца 2013 года компания активно расширяет линейку поставок компонентов по направлению коаксиальный кабель, кварцевые генераторы и конденсаторы (керамические, пленочные, электролитические), за счёт заключения дистрибьюторских договоров

Мы предлагаем:

- Конкурентоспособные цены и скидки постоянным клиентам.
- Специальные условия для постоянных клиентов.
- Подбор аналогов.
- Поставку компонентов в любых объемах, удовлетворяющих вашим потребностям.
- Приемлемые сроки поставки, возможна ускоренная поставка.
- Доставку товара в любую точку России и стран СНГ.
- Комплексную поставку.
- Работу по проектам и поставку образцов.
- Формирование склада под заказчика.
- Сертификаты соответствия на поставляемую продукцию (по желанию клиента).
- Тестирование поставляемой продукции.
- Поставку компонентов, требующих военную и космическую приемку.
- Входной контроль качества.
- Наличие сертификата ISO.

В составе нашей компании организован Конструкторский отдел, призванный помогать разработчикам, и инженерам.

Конструкторский отдел помогает осуществить:

- Регистрацию проекта у производителя компонентов.
- Техническую поддержку проекта.
- Защиту от снятия компонента с производства.
- Оценку стоимости проекта по компонентам.
- Изготовление тестовой платы монтаж и пусконаладочные работы.



Тел: +7 (812) 336 43 04 (многоканальный)  
Email: [org@lifeelectronics.ru](mailto:org@lifeelectronics.ru)