

## Features

Package	Bi-color emitting LED (Red / Yellow Green) Outer dimension: 3.0 x 2.5 x 1.5mm ( L x W x H )
Product features	<ul style="list-style-type: none"> <li>•Lead-free soldering compatible</li> <li>•RoHS compliant</li> </ul>

## Recommended Applications

- Light source for various indicator, switch etc.

# Outline Dimensions

# DRD1204W-TR

Unit : mm  
Weight : 0.013g  
Tolerance : ±0.2

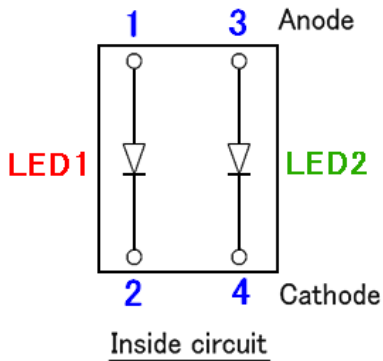
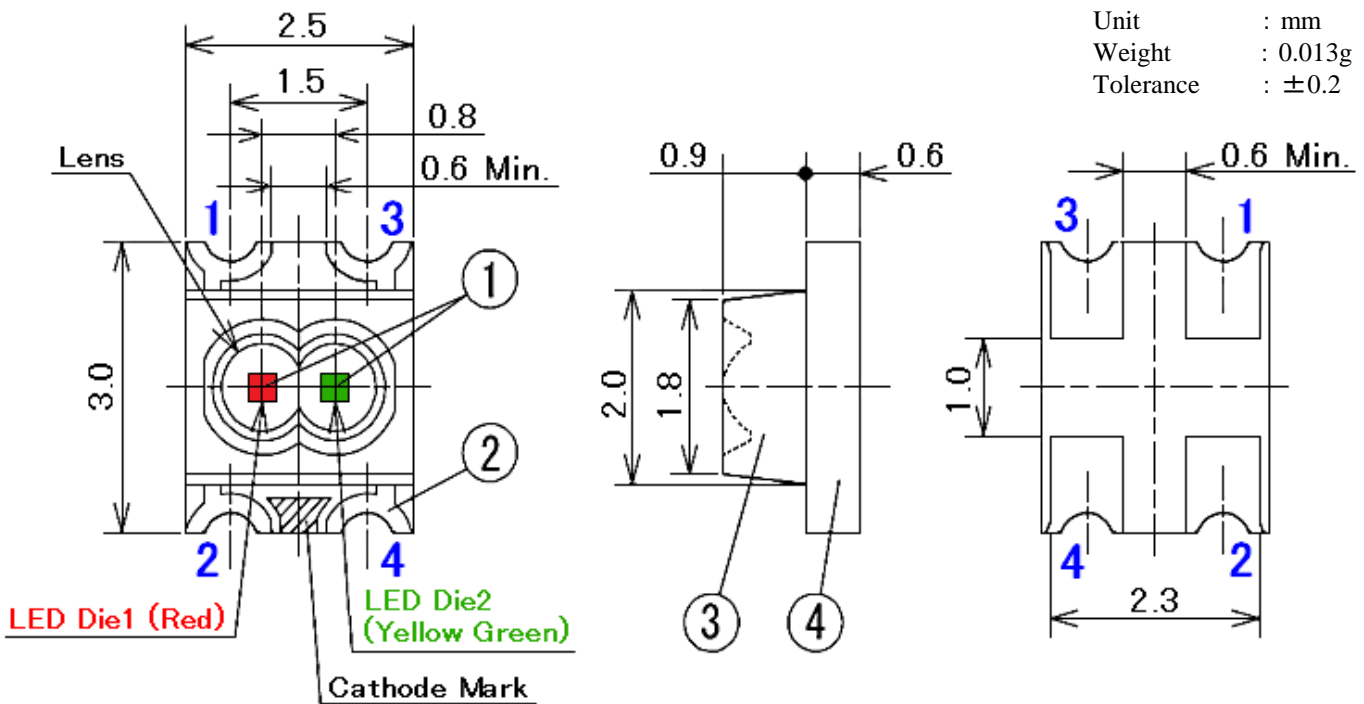

No.	Item	Material	Qty.
①	LED Die	AlGaInP	2
②	Electrode	Copper (Au Plating)	4
③	Mold Resin	Epoxy Resin	1
④	PCB	Glass fabrics	1

## Recommended soldering Pattern

Unit : mm

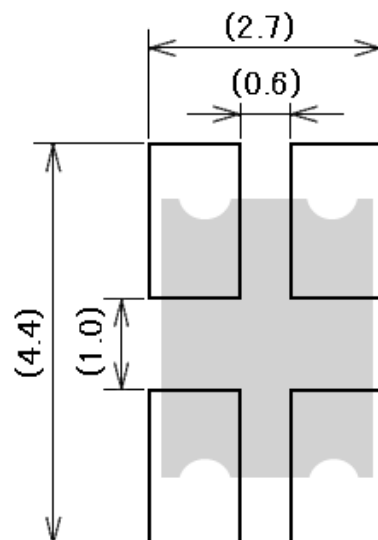

## 【 Product Overview 】

ITEM	LED Die 1	LED Die 2
DIE MATERIAL	AlGaInP	
EMITTING COLOR	RED	YELLOW-GREEN
RESIN COLOR 【EMITTING AREA】	WATER CLEAR	

## 【 Absolute Maximum Ratings 】

ITEM	SYMBOL	MAXIMUM RATINGS		UNITS
		LED Die(1)	LED Die(2)	
Power Dissipation	$P_d$	78		mW
Forward Current	$I_F$	30		mA
Repetitive Peak Forward Current "1ms, 1/20duty"	$I_{FRM}$	100		mA
$I_F$ Derate Linearly from "25°C"	$\Delta I_F$	0.43		mA/°C
$I_{FRM}$ Derate Linearly from "25°C"	$\Delta I_{FRM}$	1.33		mA/°C
Reverse Voltage	$V_R$	5		V
Operating Temperature	$T_{opr}$	-40 ~ +85		°C
Storage Temperature	$T_{stg}$	-40 ~ +100		°C
Soldering Temperature "Reflow Soldering"	$T_{sld}$	260°C MAX		

(Ta=25°C)

Notes 1

Notes 1

Notes 2

### Notes

1. Each value described on a list is rating at the time of the single color lighting.

The absolutely maximum rating in the simultaneous lighting, the values should be applied 50% Max. of each values.

2. Please refer to page 9, Soldering Conditions.

## 【 Electro and Optical Characteristics 】

### LED Die(1)

(Ta=25°C)

ITEM	SYMBOL	CONDITIONS	MIN.	TYP.	MAX.	UNITS
Forward Voltage	$V_F$	$I_F = 20\text{mA}$	-	2.0	2.4	V
Reverse Current	$I_R$	$V_R = 5\text{V}$	-	-	100	$\mu\text{A}$
Luminous Intensity	$I_V$	$I_F = 20\text{mA}$	100	-	340	mcd
Peak Wavelength	$\lambda_p$	$I_F = 20\text{mA}$	-	635	-	nm
Dominant Wavelength	$\lambda_d$	$I_F = 20\text{mA}$	621	626	634	nm
Spectral Line Half Width	$\Delta\lambda$	$I_F = 20\text{mA}$	-	15	-	nm

### LED Die(2)

(Ta=25°C)

ITEM	SYMBOL	CONDITIONS	MIN.	TYP.	MAX.	UNITS
Forward Voltage	$V_F$	$I_F = 20\text{mA}$	-	2.0	2.4	V
Reverse Current	$I_R$	$V_R = 5\text{V}$	-	-	100	$\mu\text{A}$
Luminous Intensity	$I_V$	$I_F = 20\text{mA}$	70	-	240	mcd
Peak Wavelength	$\lambda_p$	$I_F = 20\text{mA}$	-	575	-	nm
Dominant Wavelength	$\lambda_d$	$I_F = 20\text{mA}$	566	572	578	nm
Spectral Line Half Width	$\Delta\lambda$	$I_F = 20\text{mA}$	-	15	-	nm

#### Notes

Above the table of Luminous Intensity ( $I_V$ ) values and Dominant wavelength ( $\lambda_d$ ) values are the setup value of the selection machine. 【Tolerance :  $I_V \dots \pm 10\%$ ,  $\lambda_d \dots \pm 2\text{nm}$ 】

## 【 Sorting For Luminous Intensity and Dominant Wavelength 】

LED's shall be sorted out into the following ranks of Luminous Intensity and Dominant Wavelength.

Luminous Intensity (I <sub>v</sub> ) Rank
---

Rank	I <sub>v</sub> (mcd)				CONDITIONS
	LED Chip 1 (Red)		LED Chip 2 (Yellow-Green)		
	MIN.	MAX.	MIN.	MAX.	
AA	100	150	70	105	I <sub>F</sub> =20mA T <sub>a</sub> =25°C
AB			105	160	
AC			160	240	
BA	150	225	70	105	
BB			105	160	
BC			160	240	
CA	225	340	70	105	
CB			105	160	
CC			160	240	

Dominant wavelength (λ <sub>d</sub> ) Rank    LED 2 (Yellow-Green)
--

Rank	λ <sub>d</sub> (nm)		CONDITIONS
	MIN.	MAX.	
A	566	570	I <sub>F</sub> =20mA T <sub>a</sub> =25°C
B	570	574	
C	574	578	

**Notes**

Above the table of Luminous Intensity (I<sub>v</sub>) values and Dominant wavelength (λ<sub>d</sub>) values are the setup value of the selection machine. 【Tolerance : I<sub>v</sub>...±10%、λ<sub>d</sub>...±2nm】

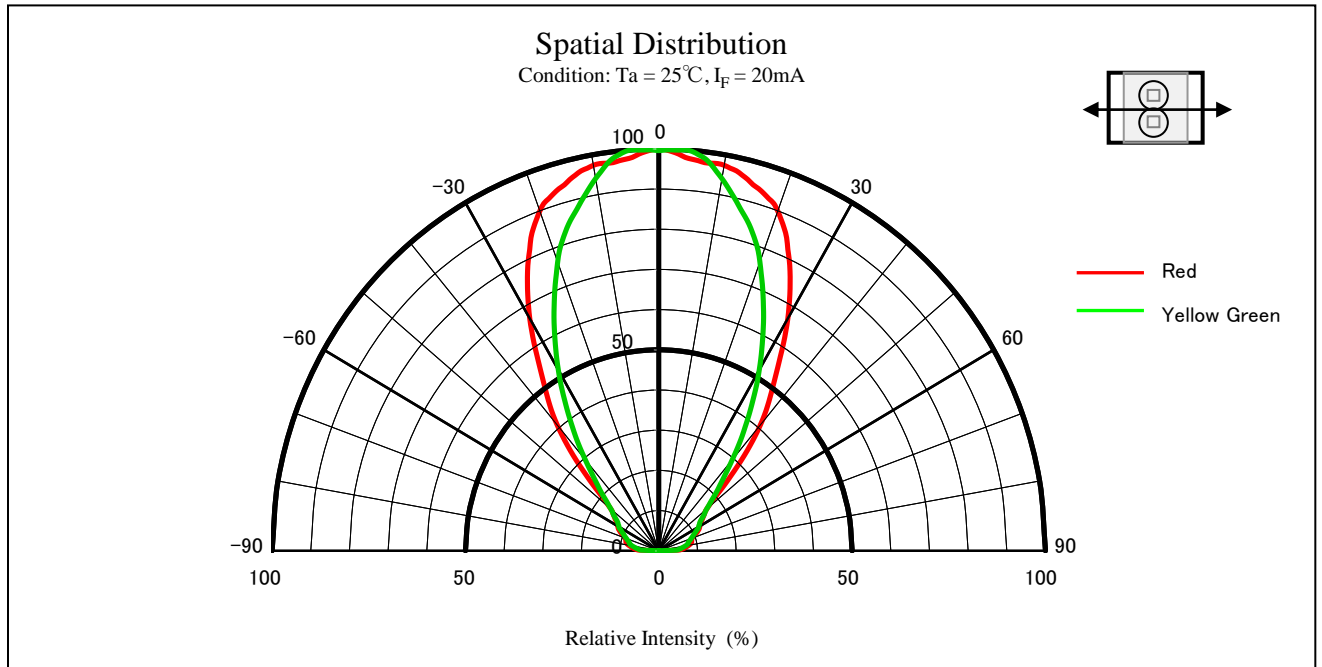
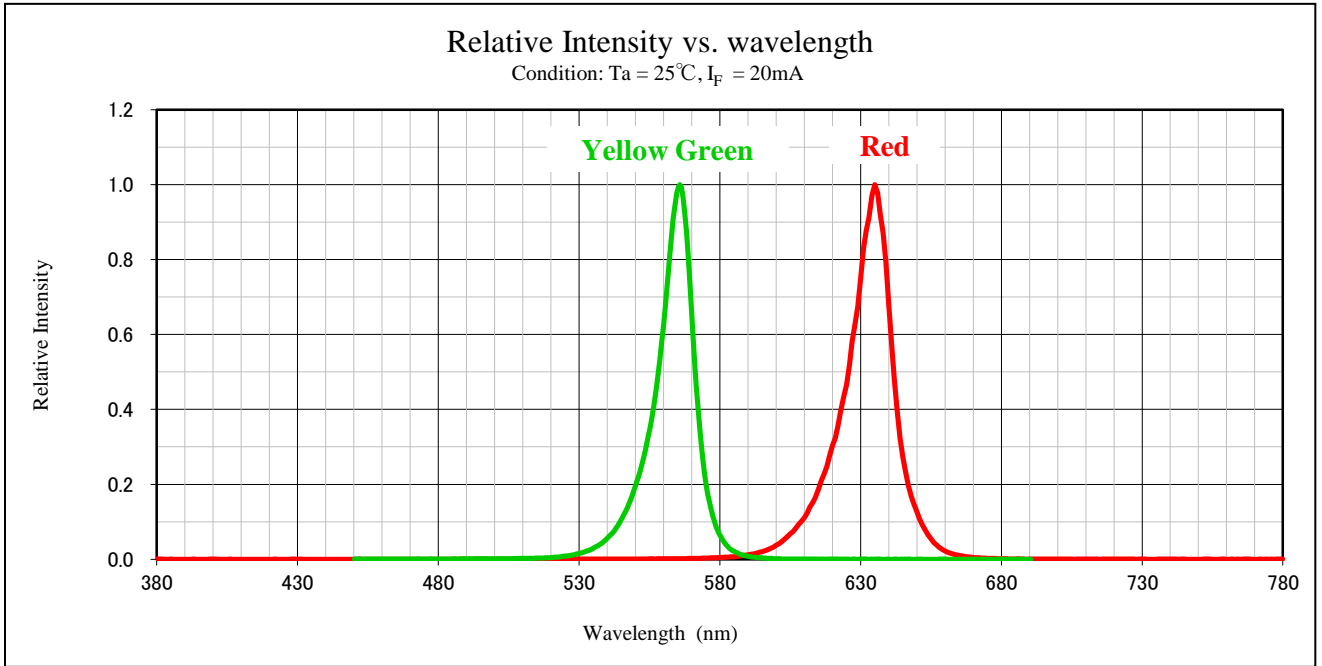

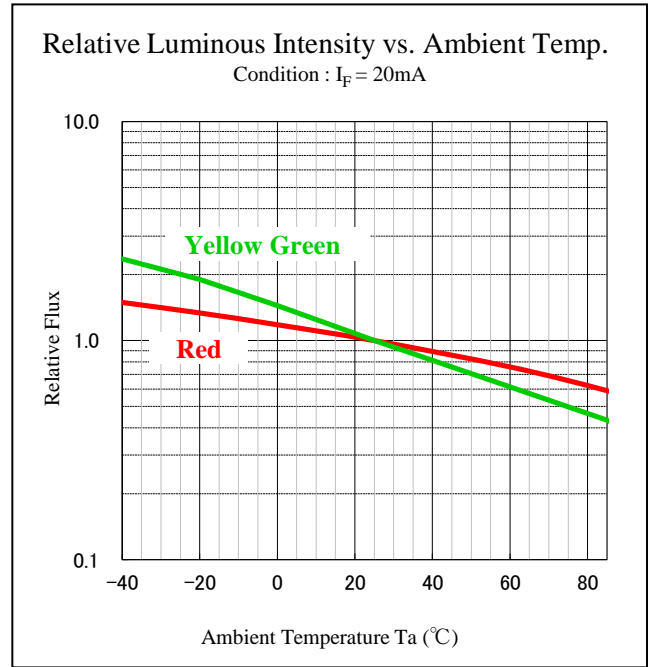
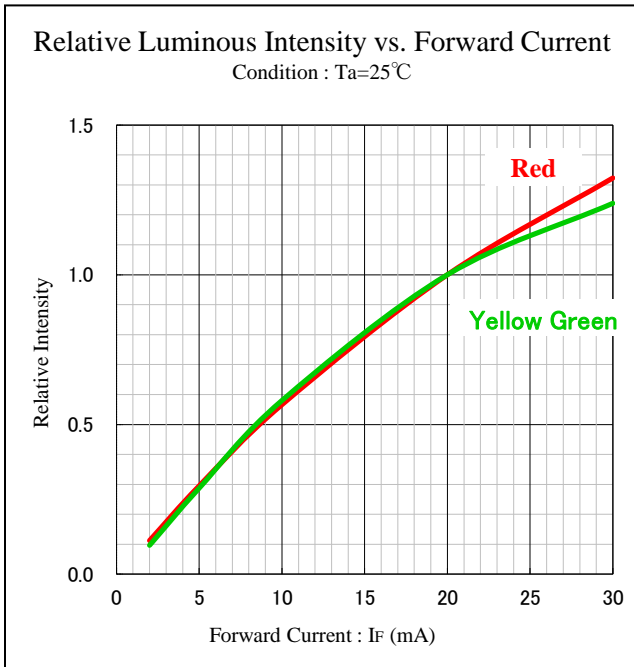
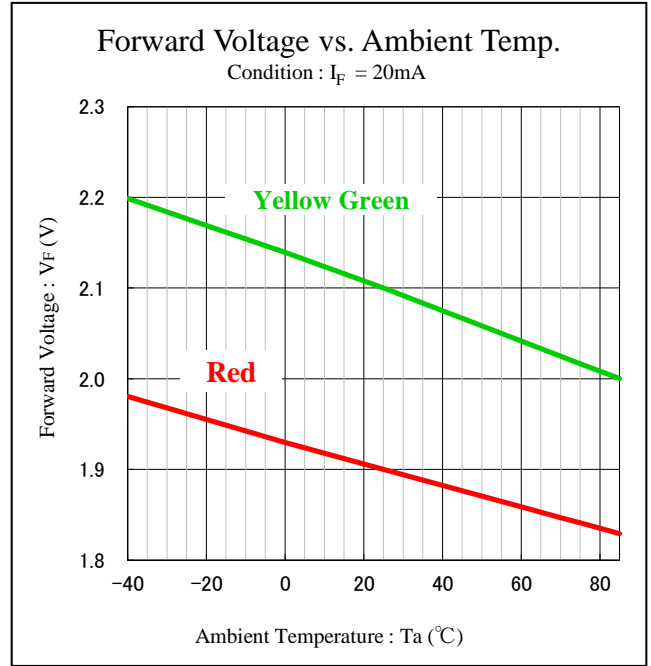
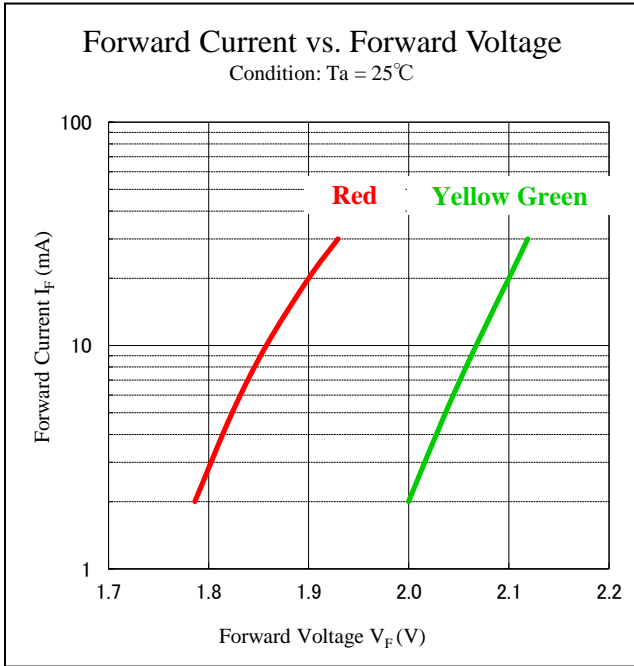

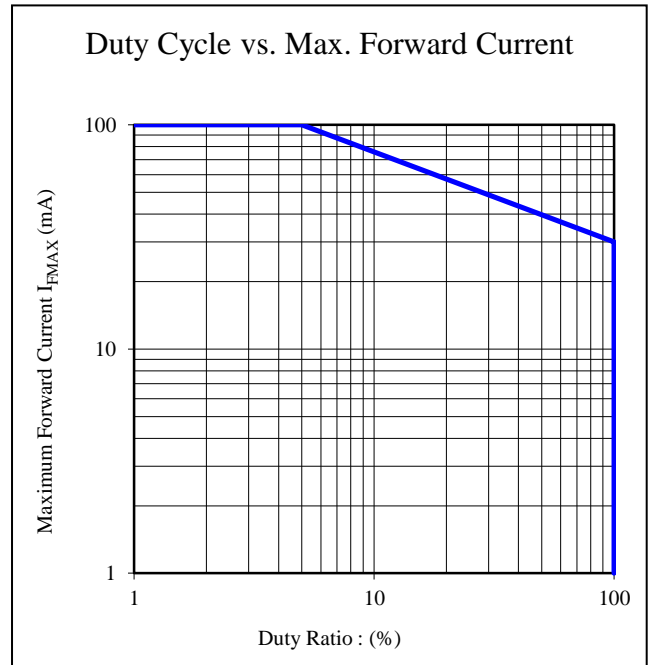
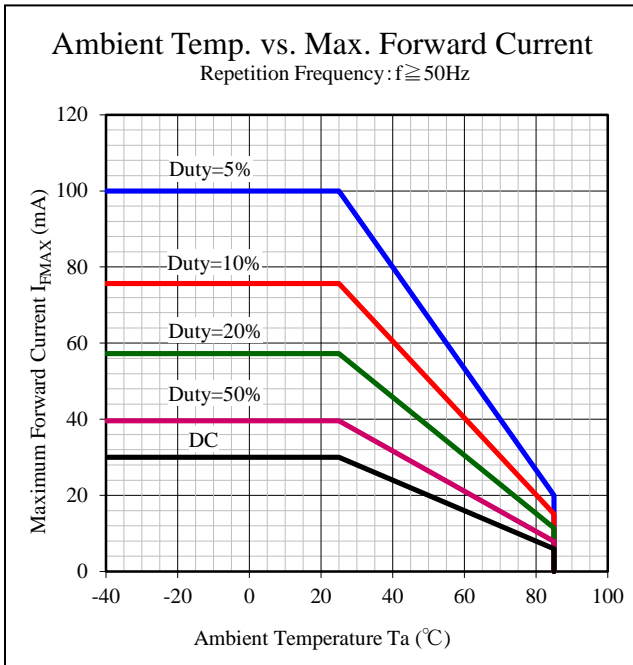
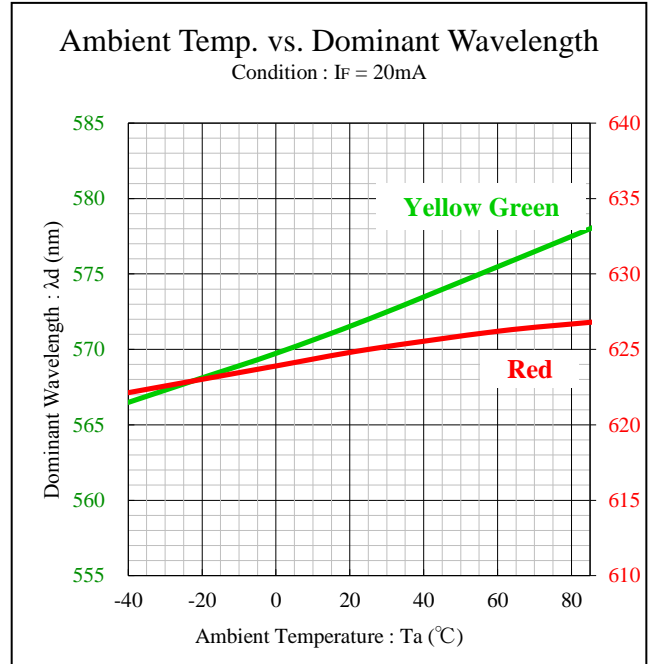
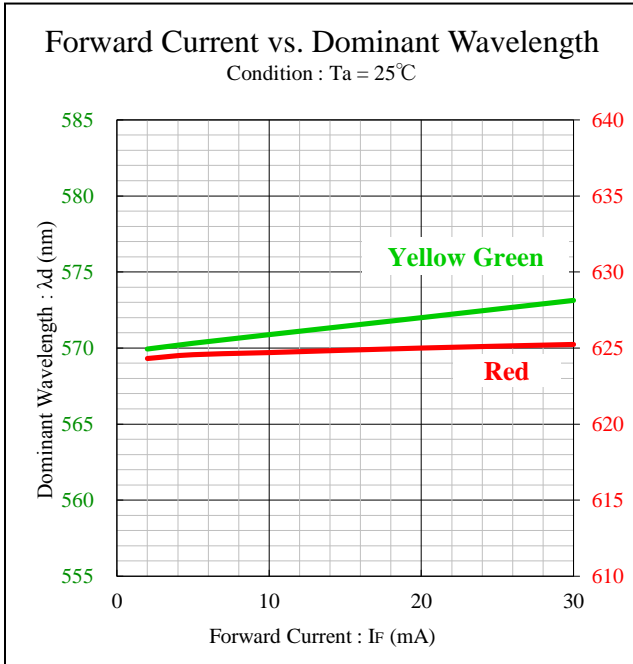



## 【Soldering Precaution】

(acc.to EIAJ-4701/300)

1. Heat stress during soldering will influence the reliability of LEDs, however that effect will vary on heating method. Also, if components of varying shape are soldered together, it is recommended to set the soldering pad temperature according to the component most vulnerable to heat (e.g., surface mount LED).
2. LED parts including the resin are not stable immediately after soldering ( when they are not at room temperature), any mechanical stress may cause damage to the product. Please avoid such stress after soldering, especially stacking of the boards which may cause the boards to warp and any other types of friction with hard materials.
3. High hardness silicone resin is used for this product's lens, but the silicone resin has the characteristic that softens at the high temperature. There is a possibility of causing the transformation, the breakage, and peeling off of the lens when it touches the resin lens at the high temperature such as immediately after soldering. Please avoid touching the lens at the high temperature.
4. Recommended temperature profile for the Reflow soldering is listed as the temperature of the resin surface. Temperature distribution varies on heating method, PCB material, other components in the assembly, and mounting density . Please do not repeat the heating process in Reflow process more than twice.

## 【Recommended Reflow Soldering Conditio】

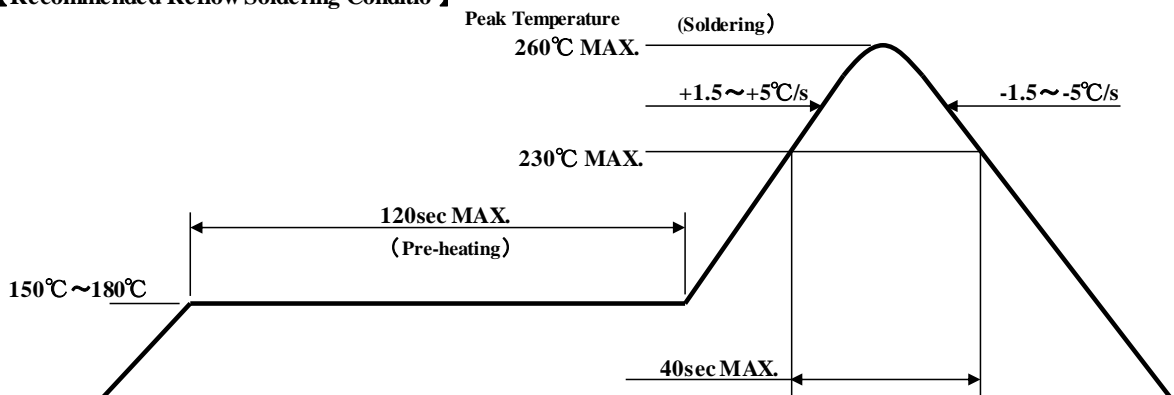

Notes 1 Temperature Profile for the reflow should be set to the surface temperature of resin which is on the top of LED. This should be the maximum temperature for soldering. Lowering the heating temperature and decreasing heating time is very effective in achieving higher reliability.

Notes 2 The reflow soldering process should be done up to twice(2 times Max). When second process is performed, interval between first and second process should be as short as possible to prevent absorption of moisture to resin of LED. The second soldering process should not be done until LEDs have returned to room temperature (by nature-cooling) after first soldering process.

5. If soldering manually, Stanley recommends using a soldering iron equipped with temperature control. During the actual soldering process, make sure that the soldering iron never touches the LED itself, and avoid the LED's electrode heating temperature reaching above the heating temperature of the solder pad. All repairs must be performed only once in the same spot, and please avoid reusing components.
6. In soldering process, immediately after iron tip is cleaned, please make sure that the soldering iron reaches the appropriate temperature, before using. Also, please avoid applying any types of pressure to the soldered components before the solder has been cooled and hardened, as it may deteriorate solder performance and solder quality.

## 【Recommended Manual Soldering Condition】

Temperature of Iron Tip	350°C MAX.
Soldering Duration, Time	3sec. Max., 1 time

7. When using adhesive material for tentative fixatives, thermosetting resin or Ultraviolet radiation (UV) setting resin with heat shall be recommended.
8. When cleaning, Ethyl alcohol, isopropyl alcohol and pure water shall be recommended. Some chemicals, including Freon substitute detergent could corrode or affect the optical characteristics of the lens or the casing surface.  
Please review the reference chart below for cleaning.  
Cleaning with ultrasonic is strongly recommended after confirming that there is no problem.
9. Flow soldering (dip soldering) is not recommended for this product.

Chemical	Adaptability
	○ / ×
Ethyl Alcohol	○
Isopropyl Alcohol	○
Pure water	○
Trichloroethylene	×
Chloroethene	×
Acetone	×
Thinner	×

10. When using freon equivalent solvent, discoloration on the LED surface may be caused by one of the first confirming that there is no problem.

Freon substitute detergent

- Clean through-750H
- Pine alpha ST-100S

11. In the case of water-washing, ensure to use pure water (not city water) and immediately after washing is over, apply forced drying to removed all moisture from the LED.

### 【Other Precautions】

1. The products are designed to achieve higher performance reliability, however, they can be influenced by usage conditions.
2. Absolute maximum ratings are set to prevent LED products from failing due to excess stress (temperature, current, voltage, etc.). These ratings must never be overrun even for a moment.
3. To achieve the highest performance reliability, it is necessary to take into account, factors such as forward voltage adjusted to the usage temperature condition, derating of the power consumption, and other variable factors.
4. Please insert Straight Protective Resistors into the circuit in order to stabilize LED operation and to prevent the device from igniting due to excess current.
5. Please check the actual performance in the assembly because the Specification Sheets are described for LED device only.
6. Please refrain from looking directly at the light source of LED at high output, as it may harm your vision.
7. The products are designed to operate without failure in recommended usage conditions. However, please take the necessary precautions to prevent fire, injury, and other damages should any malfunction or failure arise.
8. The products are manufactured to be used for ordinary electronic equipment. Please contact our sales staff beforehand when exceptional quality and reliability are required, and the failure or malfunction of the products might directly jeopardize life or health (such as for airplanes, aerospace, transport equipment, medical applications, nuclear reactor control systems and so on).
9. When there is a process of supersonic wave welding etc. after mounting the product, there is a possibility of affecting on the reliability of junction part in package (junction part of die bonding and wire bonding). Please use after affirming beforehand there is no problem.
10. The formal specification sheets shall be valid only by exchange of documents by both parties.

This products are baked (moisture removal) before packaging, and are shipped in moisture-proof packaging (as shown below) to minimize moisture absorption during transportation.  
 However, in regards to storing the products, the use of dry-box under the following conditions is recommended.  
 Moisture-proof bag as the packaging is made of anti-static material but packaging box is not.

## 【Recommended Storage Condition / Products Warranty Period】

Temperature	+5~30°C
Humidity	Under 70%

In the case of the package unopened , 6 months under 【 Recommended Storage Condition 】.  
 Please avoid rapid transition from low temp. condition to high temp. condition  
 and storage in corroding and dusty environment.

## 【Time elapsed after Package Opening】

The package should not be opened until immediately prior to its use,  
 and please keep the time frame between package opening and soldering which is **【maximum 72 h】**  
 If the device needs to be soldered twice, both soldering must be completed within 72h.

If any components should remain after their use, please seal the package and store them under the conditions  
 Described in the 【 Recommended Storage Condition 】.

The product must be required to perform baking process (moisture removal)  
 for **at least 10h and not exceed for 12h , at 60+/-5 degrees C** if following conditions apply.

1. In the case of color of indicators (those are in the package of desiccant) change or lose its blue color.
2. In the case of time is passed for 72h after the package is opened once.

Please backing process must be performed after putting out from package.

Baking may be performed in the tape-reel form, however if it is performed with the reel stacked over one another,  
 it may case deformation of the reels and taping materials, which may cause problems during production.  
 Please make sure that the product has cooled to normal temperature after performing the baking process.  
 Provided that, baking process shall be 2 times MAX.

**【Moisture-proof Packaging Specification】**

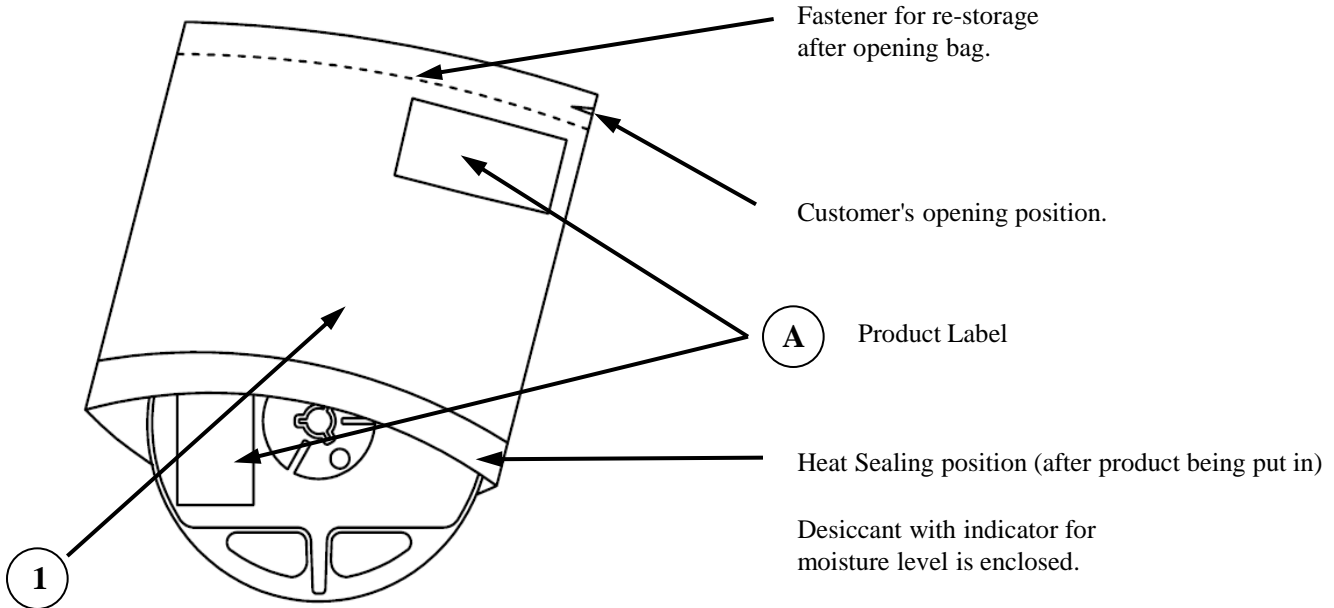

NO.	PART NAME	MATERIALS	REMARKS
①	Moisture-proof bag with Aluminum layer	PET+Al+PE	with ESD protection

**【Flow Chart-package Opening to Mounting】**

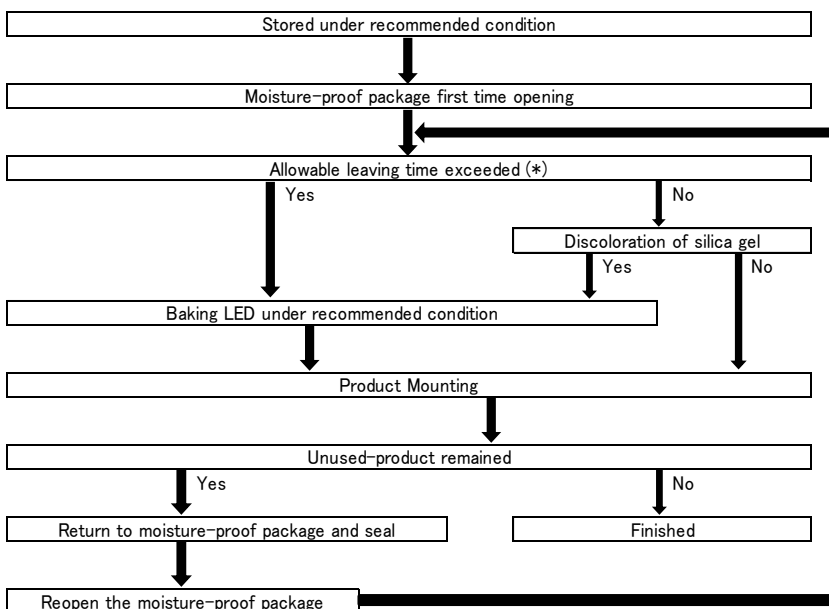

Allowable leaving time means the maximum allowable leaving time after opening package, which depends on each LED type. The allowable leaving time should be calculated from the first opening of package to the time when soldering process is finished. When judging if the allowable leaving time has exceeded or not, please subtract the soldering time. The allowable leaving time after reopening should be calculated from the first opening of package, or from the time when baking process is finished.

## 【Packing box】

( RoHS・ELV Compliant )

Box TYPE	Outline dimension L × W × H (mm)	Capacity of the box
Type A	280 × 265 × 45	3 reel
Type B	310 × 235 × 265	15 reel
Type C	440 × 310 × 265	30 reel

The above measure is all the reference value.

The box is selected out of the above table by shipping quantity.

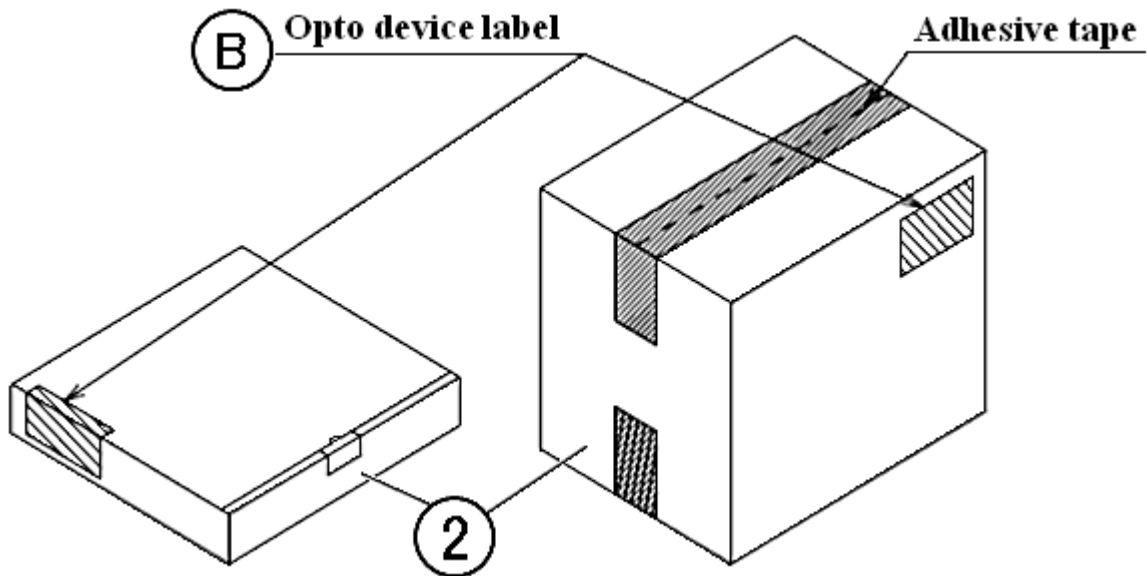

Type A

Material / box : Cardboard C5BF

Type B,C

Material / box : Cardboard K5AF

Partition : Cardboard K5BF

NO.	PART NAME	MATERIAL	REMARKS
②	Packing Box	Corrugated Cardbord	without ESD protection

(acc.to JIS-X0503(Code-39))

## 【Label Specification】

### A Product label

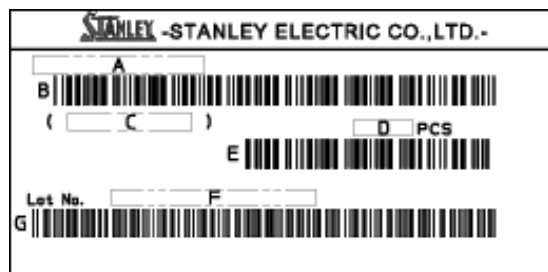

- A. Parts number
  - B. Bar-code for parts number
  - C. Parts code (In-house identification code for each parts number)
  - D. Packed parts quantity
  - E. Bar-Code for packed parts quantity
  - F. Lot number & Rank
- (Please refer to Lot Number Notational System for details )
- G. Bar-Code for Lot number & Rank

### B Opto device label

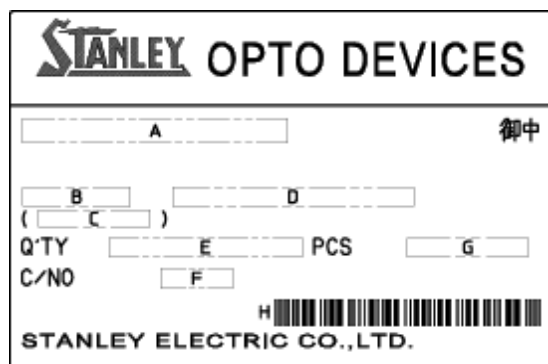

- A. Customer Name
- B. Parts Type
- C. Parts Code
- D. Parts Number
- E. Packed Parts Quantity
- F. Carton Number
- G. Shipping Date
- H. Bar-Code for In-house identification Number

<Remark> Bar-code font : acc.to Code-39(JIX0503)

# Taping and Reel Specifications

# DRD1204W-TR

(acc.to JIS-C0806-03)

## 【Appearance】

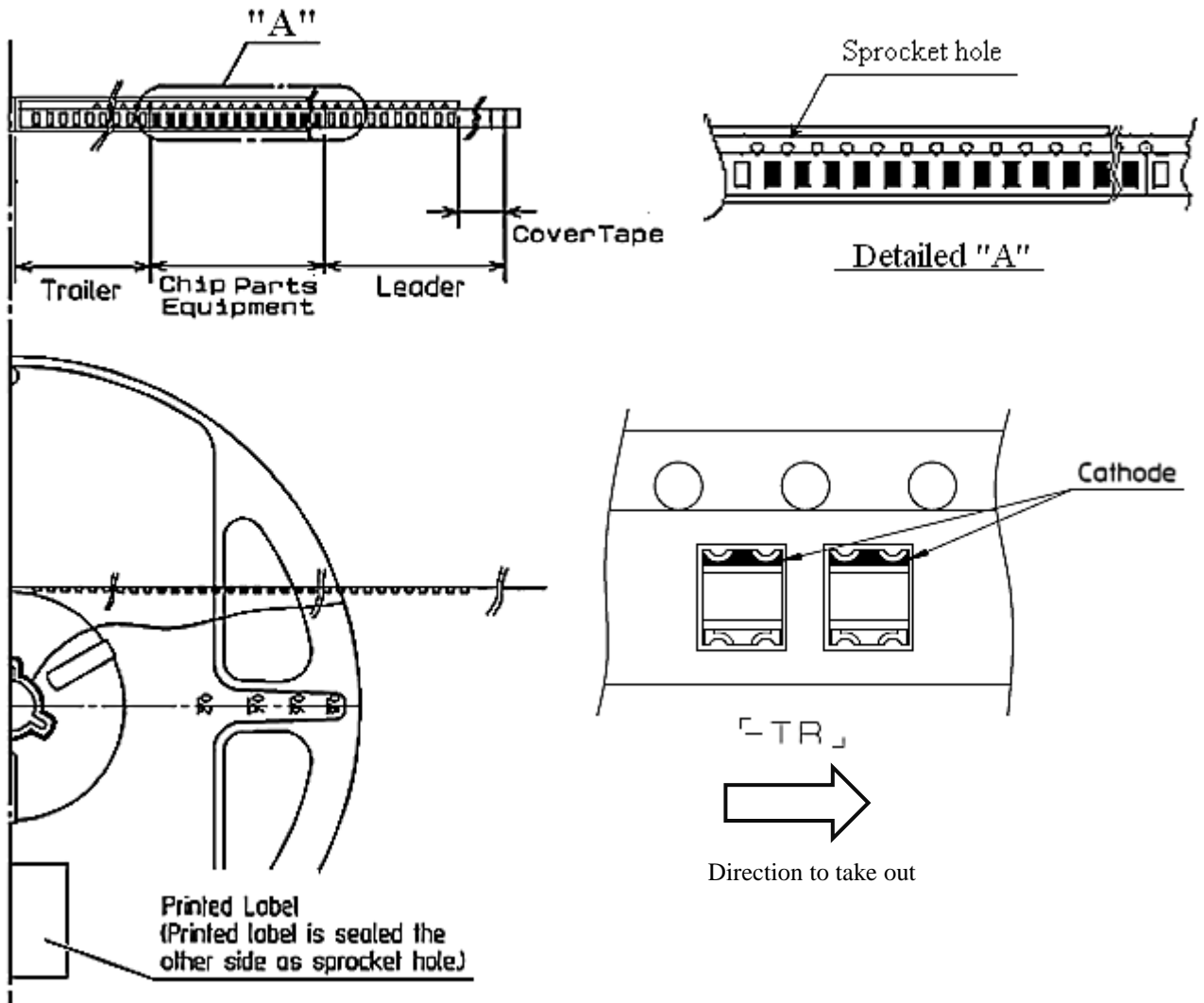

### Note

"-TR" means Cathode Side of LEDs should be placed on the sprocket-hole side.

Items		Specifications	Remarks
Leader area	Cover-tape	Cover-tape shall be longer than <b>200mm</b> without carrier-tape	The end of cover-tape shall be held with adhesive tape.
	Carrier-tape	Empty pocket shall be more than <b>10 pieces.</b>	Please refer to the above figure for Taping & reel orientation .
Trailer area		Empty pocket shall be more than <b>15 pieces.</b>	The end of taping shall be inserted into a slit of the hub.



# Taping and Reel Specifications

# DRD1204W-TR

(acc.to JIS-C0806-03)

Unit :mm

## 【Taping Dimensions】

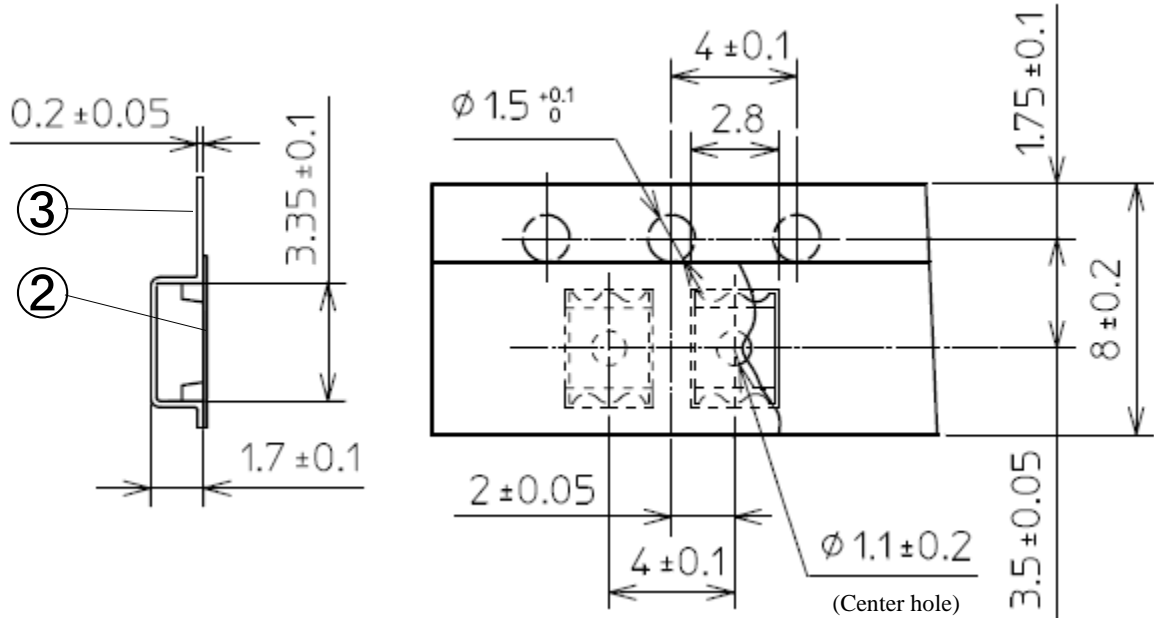

## 【Reel Dimensions】

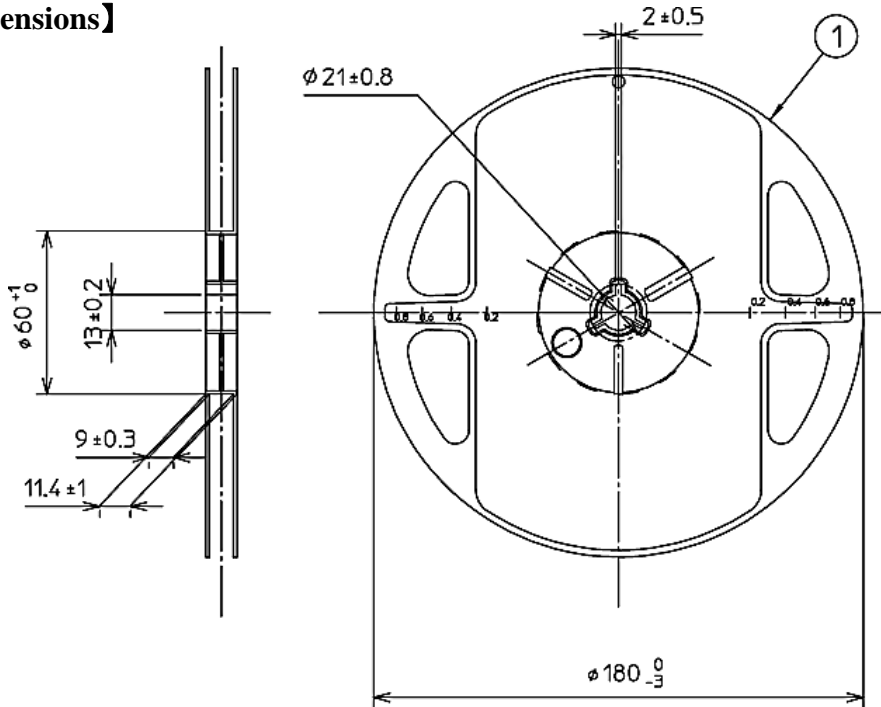

NO.	PART NAME	REMARKS
①	Carrier reel	with ESD protection
②	Cover tape	with ESD protection
③	Carrier tape	with ESD protection

## Taping and Reel Specifications

# DRD1204W-TR

(acc.to JIS-C0806-03)

### 【 Qty. per Reel】

2,500 pcs./ reel

### 【Mechanical strength】

Cover-tape adhesive strength shall be 0.1~1.0N ( An angle between carrier-tape and cover-tape shall be 170 deg. ).  
Both tapes shall be so sealed that the contained parts will not come out from the tape when it is bent at a radius of 15mm.

### 【 Others】

- Reversed-orientation, Up-side down placing, side placing and out of spec. parts mix shall not be held.
- The number of empty pockets within a reel is made into 5pcs. or less and no more than 1 connecting empty pockets of taping.

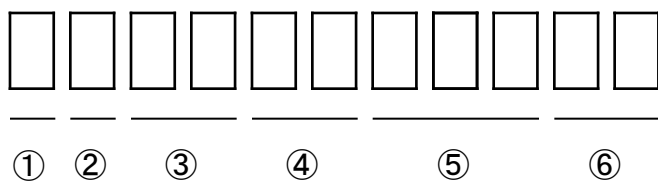

① - 1digit : Production Location (Mark identify alphabet)

② - 1digit : Production Year (Last digit of Production Year 2009→9,2010→0,2011→1,···)

③ - 2digits : Production Month (Jan. to Sep. , should be 01,02,03,·····)

④ - 2digits : Production Date

⑤ - 3digits : Serial Number

⑥ - 2digits : Tape and Reel following Number

This product is in compliance with RoHS・ELV.

Prohibition substance and it's criteria value of RoHS・ELV are as follows.

- RoHS instruction ..... Refer to following (1)~(6).
- ELV instruction ..... Refer to following (1)~(4).

	Substance Group Name	Criteria Value
(1)	Lead and its compounds	1,000ppm Max
(2)	Cadmium and its compounds	100ppm Max
(3)	Mercury and its compounds	1,000ppm Max
(4)	Hexavalent chromium	1,000ppm Max
(5)	PBB	1,000ppm Max
(6)	PBDE	1,000ppm Max

## 1. Reliability Testing Result

Test Item	Standard	Test Condition	Duration	Failure
Operating Life	EIAJ ED-4701 /100(101)	Ta = 25°C, I <sub>F</sub> = 30mA	1,000h	0 / 25
High Temperature Storage Life	EIAJ ED-4701 /200(201)	Ta = 100°C	1,000h	0 / 25
Low Temperature Storage Life	EIAJ ED-4701 /200(202)	Ta = -40°C	1,000h	0 / 25
Wet High Temperature Storage Life	EIAJ ED-4701 /100(101)	Ta=60°C±2°C, Rh=90%±5%	1,000h	0 / 25
Thermal Shock	EIAJ ED-4701 /100(105)	Ta= 100°C ~ -40°C (each 15min)	5 cycles	0 / 25
Resistance to Reflow Soldering	EIAJ ED-4701 /300(301)	Preheating : 150~180°C 120s Max. Soldering : 230°C 40s Max. Peak Temperature : 260°C	2times	0 / 25
Vibration, Variable Frequency	EIAJ ED-4701 /400(403)	98.1m/s <sup>2</sup> (10G) 100~2,000Hz 20min Sweep XYZ direction	2h of each direction	0 / 10

## 2. Failure Criteria

Item	Symbol	Condition	Failure Criteria
Luminous Intensity	I <sub>V</sub>	20mA	Testing Min. Value < Standard Min. Value × 0.5
Forward Voltage	V <sub>F</sub>	20mA	Testing Max. Value ≥ Standard Max. Value × 1.2
Reverse Current	I <sub>R</sub>	V <sub>R</sub> =5V	Testing Max. Value ≥ Standard Max. Value × 2.5
Cosmetic appearance	-	-	Notable, decollation, deformation and cracking

## Special Notice to Customers Using the Products and Technical Information Shown in This Data Sheet

- 1) The technical information shown in the data sheets are limited to the typical characteristics and circuit examples of the referenced products. It does not constitute the warranting of industrial property nor the granting of any license.
- 2) For the purpose of product improvement, the specifications, characteristics and technical data described in the data sheets are subject to change without prior notice. Therefore it is recommended that the most updated specifications be used in your design.
- 3) When using the products described in the data sheets, please adhere to the maximum ratings for operating voltage, heat dissipation characteristics, and other precautions for use. We are not responsible for any damage which may occur if these specifications are exceeded.
- 4) The products that have been described to this catalog are manufactured so that they will be used for the electrical instrument of the benchmark (OA equipment, telecommunications equipment, AV machine, home appliance and measuring instrument).  
The application of aircrafts, space borne application, transportation equipment, medical equipment and nuclear power control equipment, etc. needs a high reliability and safety, and the breakdown and the wrong operation might influence the life or the human body. Please consult us beforehand if you plan to use our product for the usages of aircrafts, space borne application, transportation equipment, medical equipment and nuclear power control equipment, etc. except OA equipment, telecommunications equipment, AV machine, home appliance and measuring instrument.
- 5) In order to export the products or technologies described in this data sheet which are under the “Foreign Exchange and Foreign Trade Control Law,” it is necessary to first obtain an export permit from the Japanese government.
- 6) No part of this data sheet may be reprinted or reproduced without prior written permission from Stanley Electric Co., Ltd.
- 7) The most updated edition of this data sheet can be obtained from the address below:  
<http://www.stanley-components.com/en/>

Компания «Life Electronics» занимается поставками электронных компонентов импортного и отечественного производства от производителей и со складов крупных дистрибьюторов Европы, Америки и Азии.

С конца 2013 года компания активно расширяет линейку поставок компонентов по направлению коаксиальный кабель, кварцевые генераторы и конденсаторы (керамические, пленочные, электролитические), за счёт заключения дистрибьюторских договоров

Мы предлагаем:

- Конкурентоспособные цены и скидки постоянным клиентам.
- Специальные условия для постоянных клиентов.
- Подбор аналогов.
- Поставку компонентов в любых объемах, удовлетворяющих вашим потребностям.
- Приемлемые сроки поставки, возможна ускоренная поставка.
- Доставку товара в любую точку России и стран СНГ.
- Комплексную поставку.
- Работу по проектам и поставку образцов.
- Формирование склада под заказчика.
- Сертификаты соответствия на поставляемую продукцию (по желанию клиента).
- Тестирование поставляемой продукции.
- Поставку компонентов, требующих военную и космическую приемку.
- Входной контроль качества.
- Наличие сертификата ISO.

В составе нашей компании организован Конструкторский отдел, призванный помогать разработчикам, и инженерам.

Конструкторский отдел помогает осуществить:

- Регистрацию проекта у производителя компонентов.
- Техническую поддержку проекта.
- Защиту от снятия компонента с производства.
- Оценку стоимости проекта по компонентам.
- Изготовление тестовой платы монтаж и пусконаладочные работы.



Тел: +7 (812) 336 43 04 (многоканальный)

Email: [org@lifeelectronics.ru](mailto:org@lifeelectronics.ru)