

PART NUMBER	PART REV	USB TYPE	COUPLING TYPE
DCC-US3AB-180	0A	USB 3.0 A	QUICK CONNECT
DCC-US3AT-180	0A	USB 3.0 A	THREADED

NOTES:

- DCC-US3AB-180 SHOWN IN EXPLODED VIEW. (USB 3.0 TYPE A WITH QUICK CONNECT COUPLING.)

MATERIALS:

PLUG HOUSING: THERMOPLASTIC
 SEALING NUT, COUPLING RING: THERMOPLASTIC
 SEALING RING: ELASTOMER
 O-RING: ELASTOMER
 INSERT: THERMOPLASTIC
 USB 3.0 PLUG:
 INSULATOR: THERMOPLASTIC, BLUE
 CONTACTS: COPPER ALLOY, GOLD PLATED
 SHIELD: STEEL, NICKEL PLATED

ELECTRICAL:

CONTACT RESISTANCE: 50 MILLIOHMS MAX
 CONTACT CURRENT RATING: 1.0A DC MAX
 INSULATION RESISTANCE: 100 MEGAOHMS MIN
 WITHSTANDING VOLTAGE: 750V AC FOR 1 MINUTE

PRODUCT RATING:

IP67 & IP68, NEMA 250 (6P) WHEN MATED
 USB A PLUG: USB 3.0

OTHER:

OPERATING TEMPERATURE: -25°C TO +80°C (-13°F TO +176°F)
 RECOMMENDED CABLE TYPE: SOLID OR STRANDED CONDUCTORS
 OUTER CABLE O.D. RANGE:
 PRODUCT 180 SERIES: 0.171-0.208 [4.34mm-5.28mm]

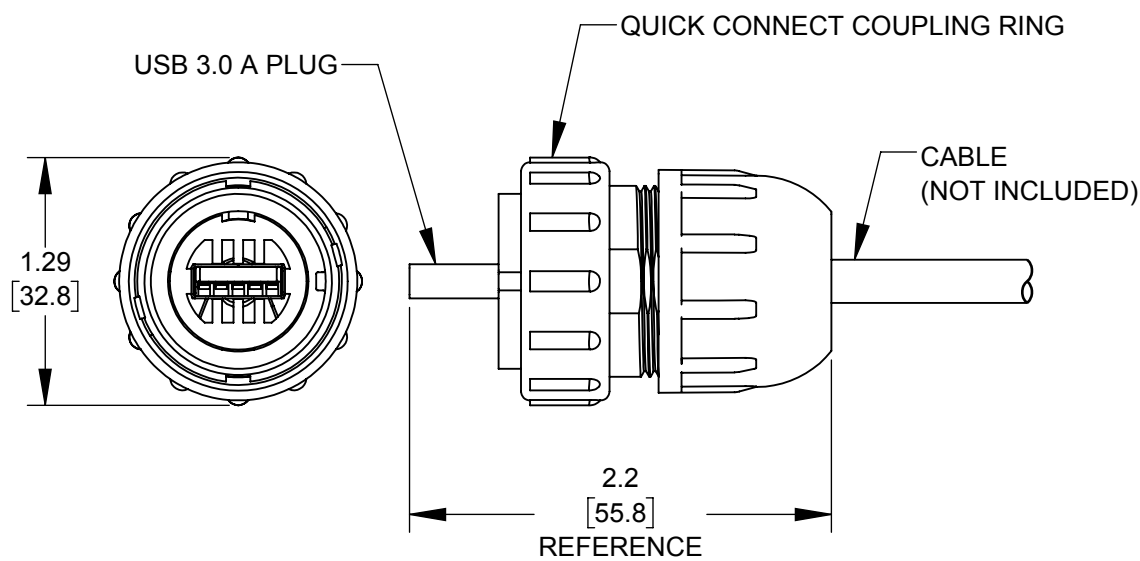
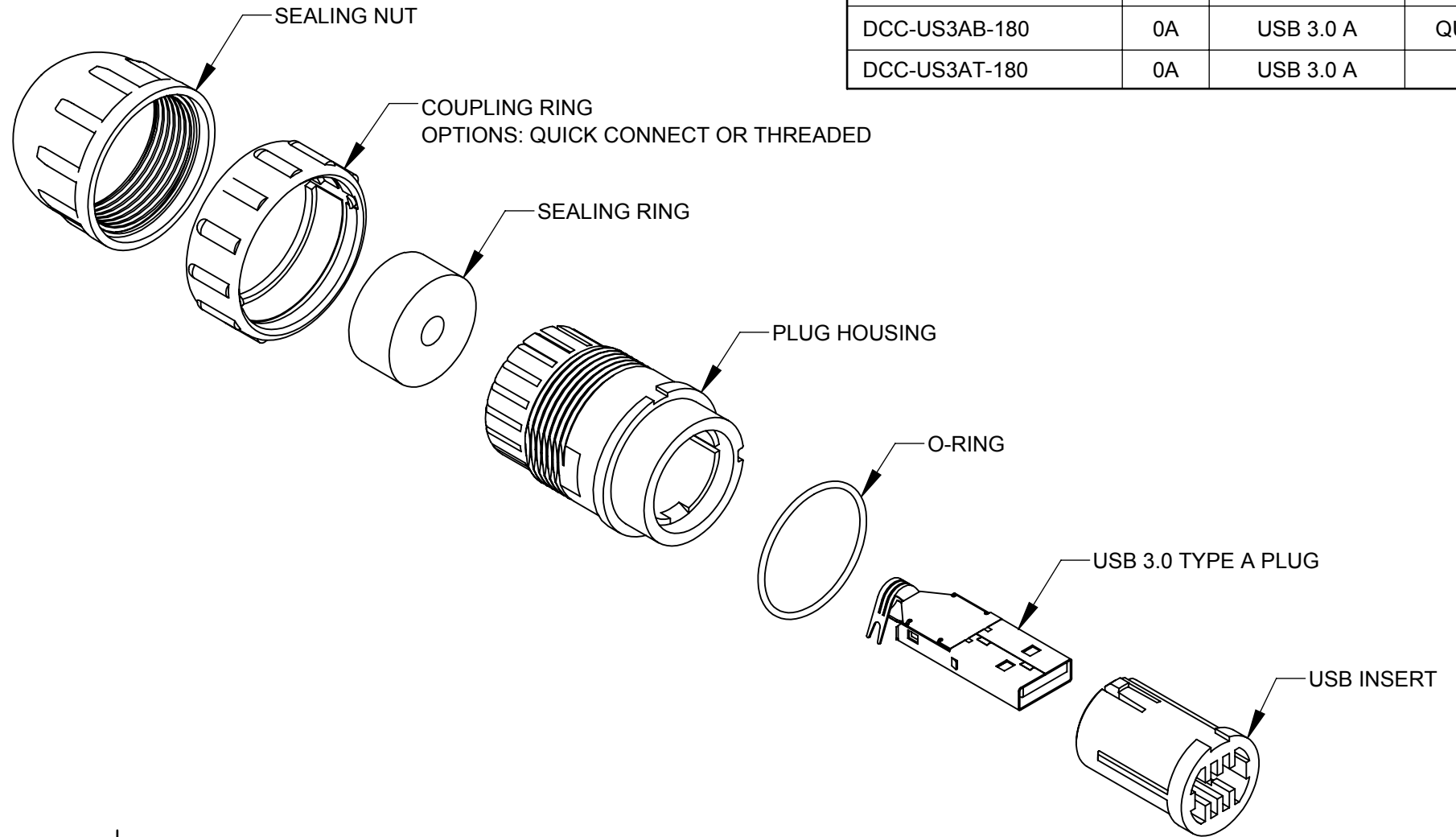

DCC-US3AB-180
 USB 3.0 TYPE A WITH QUICK CONNECT COUPLING

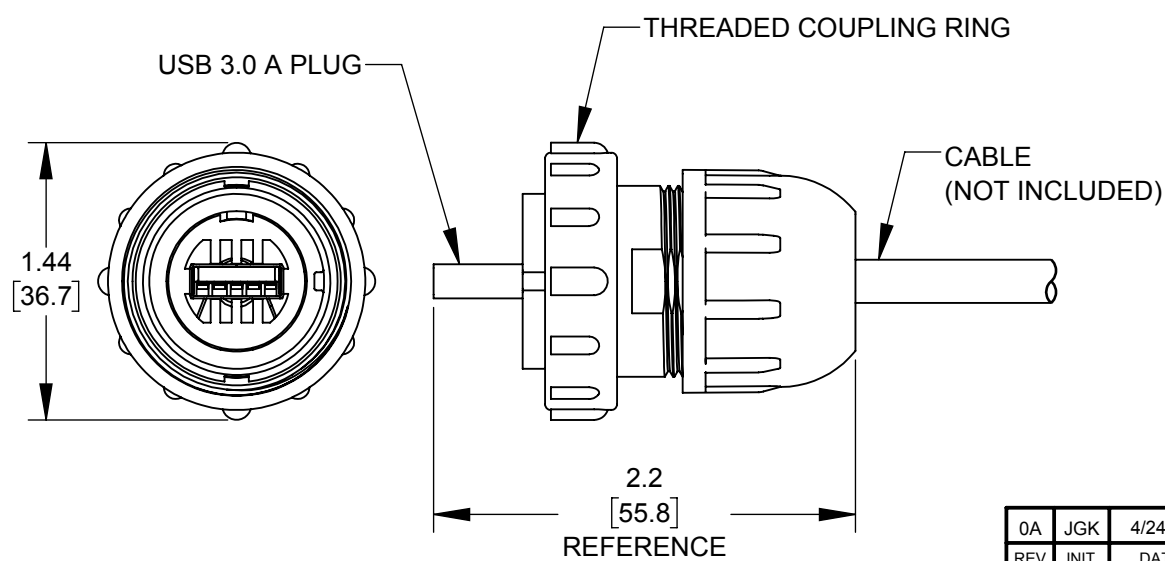

DCC-US3AT-180
 USB 3.0 TYPE A WITH THREADED COUPLING

DIMENSIONS IN BRACKET [] ARE METRIC.

RoHS COMPLIANT

CUSTOMER DRAWING

0A	JGK	4/24/17	DRAWING CREATED FOR PROJECT #12012.	
REV.	INIT.	DATE	DESCRIPTION	
			ORIG. DRAWN BY: JGK	DATE: 4/24/17
ALL INFORMATION ILLUSTRATED IS THE PROPERTY OF CONXALL CORPORATION. UNAUTHORIZED DUPLICATION OR DISTRIBUTION OF THIS DOCUMENT IS PROHIBITED.			CHECKED BY:	
ALL UNITS ARE IN FEET, INCHES, FRACTION OF INCHES AND DECIMALS. UNLESS OTHERWISE SPECIFIED TOLERANCES: 3 PLACE DECIMALS ±.005 ANGLES ±1° FRACTIONS ±1/16			APPROVED BY:	
SCALE: NTS	SIZE: B	SHEET: 1 OF 3	TITLE: INDUSTRIAL USB 3.0 A PLUG FIELD INSTALLABLE DATA-CON-X	
FILE: DCC-US3AX SERIES_CD	DIRECTORY: SLW	PART NUMBER: DCC-US3AX-180 SERIES	CUSTOMER: STANDARD PRODUCT	
- CRITICAL CHARACTERISTIC FLAG PER SPEC. XXXX			REV: 0A	



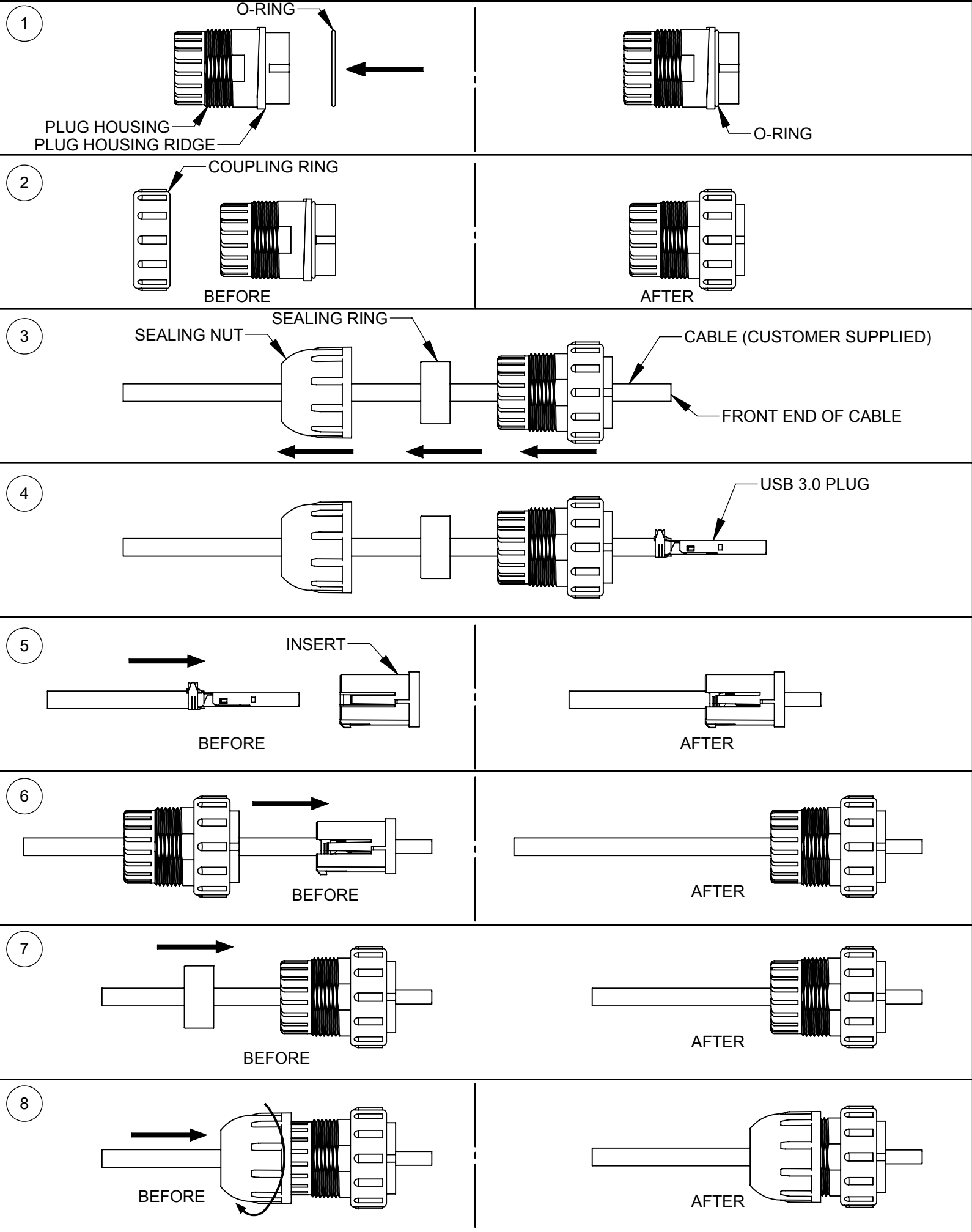

ASSEMBLY INSTRUCTIONS:

1. SLIDE THE O-RING ONTO THE FRONT END OF THE PLUG HOUSING UNTIL IT SEATS UP AGAINST THE RIDGE OF THE PLUG HOUSING.
2. SLIDE THE COUPLING RING OVER THE PLUG HOUSING.
NOTE: MAKE SURE THE FRONT OF THE COUPLING RING CAN SLIDE PAST THE RIDGE ON THE PLUG HOUSING. IF NOT, IT IS INSERTED THE WRONG WAY.
3. SLIDE THE SEALING NUT, SEALING RING, AND PLUG HOUSING/COUPLING RING OVER THE FRONT END OF THE CABLE IN THE FOLLOWING ORDER:
1ST. SEALING NUT.
2ND. SEALING RING.
3RD. PLUG HOUSING/COUPLING RING.
4. TERMINATE THE USB PLUG TO THE CABLE.
NOTE: SEE FIGURE 1 FOR TERMINATION GUIDE.
SEE FIGURE 2 FOR RECOMMENDED STRIPPING DETAIL.
SEE FIGURE 4 FOR TYPICAL USB 3.0 WIRING ASSIGNMENT.
5. SLIDE THE USB PLUG INTO THE BACK END OF THE INSERT UNTIL IT SNAPS INTO PLACE.
NOTE: SEE FIGURE 5 FOR INSERT AND PLUG ALIGNMENT.
6. SLIDE THE INSERT/USB PLUG INTO THE FRONT END OF THE PLUG HOUSING UNTIL IT SNAPS INTO PLACE.
7. PUSH THE SEALING RING INTO THE REAR OF THE PLUG HOUSING.
NOTE: NO PART OF THE SEALING RING SHOULD EXTEND PAST THE REAR OF THE PLUG HOUSING.
8. SCREW THE SEALING NUT ONTO THE PLUG HOUSING.

CUSTOMER DRAWING

RoHS COMPLIANT

0A	JGK	4/24/17	SEE PAGE 1.
REV.	INIT.	DATE	DESCRIPTION
	JGK	4/24/17	INDUSTRIAL USB 3.0 A PLUG
<small>ALL INFORMATION ILLUSTRATED IS THE PROPERTY OF CONXALL CORPORATION. UNAUTHORIZED DUPLICATION OR DISTRIBUTION OF THIS DOCUMENT IS PROHIBITED.</small>			<p>601 E. WILDWOOD VILLA PARK, IL 60181</p>
<small>ALL UNITS ARE IN FEET, INCHES, FRACTION OF INCHES AND DECIMALS. UNLESS OTHERWISE SPECIFIED TOLERANCES: 3 PLACE DECIMALS ±.005 ANGLES ±1° FRACTIONS ±1/16</small>			
<small>△ - CRITICAL CHARACTERISTIC FLAG PER SPEC. XXXX</small>			TITLE: INDUSTRIAL USB 3.0 A PLUG FIELD INSTALLABLE DATA-CON-X CUSTOMER: STANDARD PRODUCT
SCALE	SIZE	SHEET	PART NUMBER: DCC-US3AX-180 SERIES
NTS	B	2 OF 3	REV 0A
FILE: DCC-US3AX SERIES_CD	DIRECTORY: SLW		

FIGURE 1

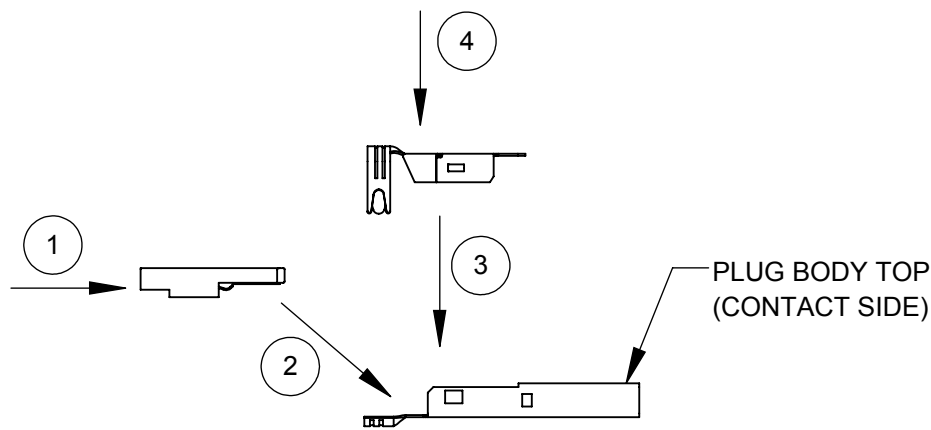

USB ASSEMBLY INSTRUCTIONS

1. SOLDER THE CABLE WIRES TO THE INSULATOR BODY. SEE FIGURE 2 FOR RECOMMENDED CABLE STRIPPING DETAIL AND FIGURE 3 FOR PINOUT. FIGURE 4 SHOWS THE USB 3.0 TYPICAL WIRING ASSIGNMENT.
2. PLACE THE INSULATOR BODY ASSEMBLY INTO THE FRONT SHELL AND PUSH FORWARD UNTIL IT SITS FIRMLY INTO THE FRONT SHELL.
3. SNAP THE BACK SHELL ONTO THE FRONT SHELL.
4. CRIMP THE BACK SHELL CLAMP AROUND THE CABLE JACKET.

FIGURE 2

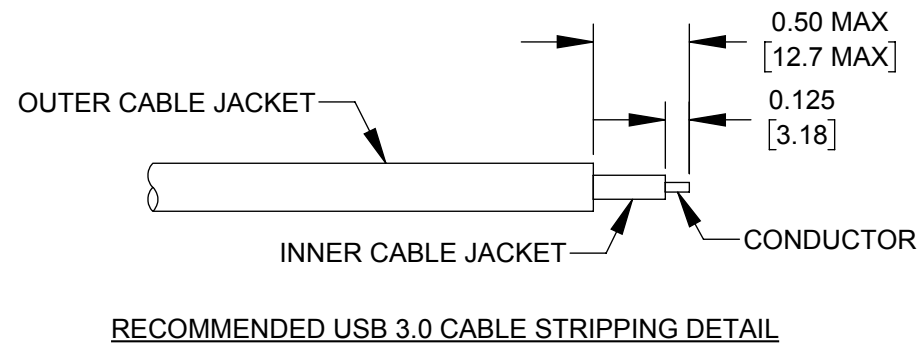

FIGURE 3

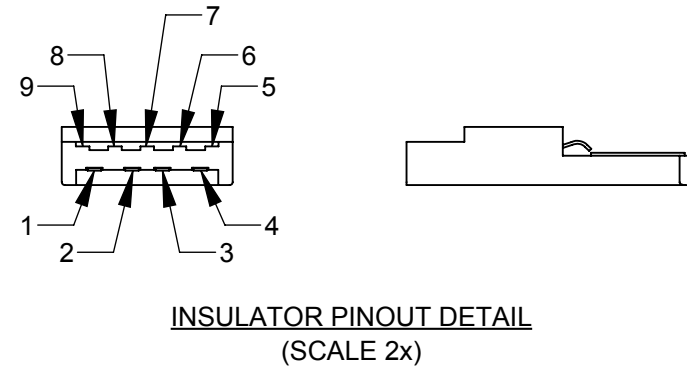
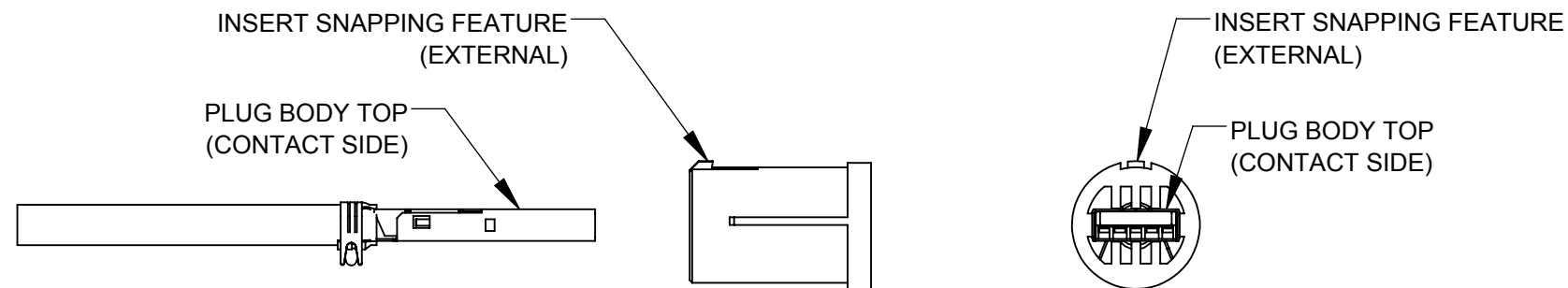

FIGURE 4

TYPICAL USB 3.0 A WIRING	
PIN	CABLE COLOR
1	RED
2	WHITE
3	GREEN
4	BLACK
5	BLUE
6	YELLOW
7	DRAIN WIRE
8	PURPLE
9	ORANGE
SHIELD	BRAID

FIGURE 5



THE PLUG BODY TOP AND THE INSERT EXTERNAL FEATURE MUST BE ALIGNED.

RoHS COMPLIANT

CUSTOMER DRAWING

0A	JGK	4/24/17	SEE PAGE 1.
REV.	INIT.	DATE	DESCRIPTION
	JGK	4/24/17	ORIG. DRAWN BY: DATE: 4/24/17
ALL INFORMATION ILLUSTRATED IS THE PROPERTY OF CONXALL CORPORATION. UNAUTHORIZED DUPLICATION OR DISTRIBUTION OF THIS DOCUMENT IS PROHIBITED.			<p>601 E. WILDWOOD VILLA PARK, IL 60181</p>
<small>ALL UNITS ARE IN FEET, INCHES, FRACTION OF INCHES AND DECIMALS. UNLESS OTHERWISE SPECIFIED TOLERANCES: 3 PLACE DECIMALS ±.005 ANGLES ±1° FRACTIONS ±1/16</small>			
<small>UNLESS OTHERWISE SPECIFIED TOLERANCES: 3 PLACE DECIMALS ±.005 ANGLES ±1° FRACTIONS ±1/16</small>			TITLE: INDUSTRIAL USB 3.0 A PLUG FIELD INSTALLABLE DATA-CON-X CUSTOMER: STANDARD PRODUCT
SCALE	SIZE	SHEET	
NTS	B	3 OF 3	
FILE:	DIRECTORY:	PART NUMBER:	REV
DCC-US3AX SERIES_CD	SLW	DCC-US3AX-180 SERIES	0A

Компания «Life Electronics» занимается поставками электронных компонентов импортного и отечественного производства от производителей и со складов крупных дистрибьюторов Европы, Америки и Азии.

С конца 2013 года компания активно расширяет линейку поставок компонентов по направлению коаксиальный кабель, кварцевые генераторы и конденсаторы (керамические, пленочные, электролитические), за счёт заключения дистрибьюторских договоров

Мы предлагаем:

- Конкурентоспособные цены и скидки постоянным клиентам.
- Специальные условия для постоянных клиентов.
- Подбор аналогов.
- Поставку компонентов в любых объемах, удовлетворяющих вашим потребностям.
- Приемлемые сроки поставки, возможна ускоренная поставка.
- Доставку товара в любую точку России и стран СНГ.
- Комплексную поставку.
- Работу по проектам и поставку образцов.
- Формирование склада под заказчика.
- Сертификаты соответствия на поставляемую продукцию (по желанию клиента).
- Тестирование поставляемой продукции.
- Поставку компонентов, требующих военную и космическую приемку.
- Входной контроль качества.
- Наличие сертификата ISO.

В составе нашей компании организован Конструкторский отдел, призванный помогать разработчикам, и инженерам.

Конструкторский отдел помогает осуществить:

- Регистрацию проекта у производителя компонентов.
- Техническую поддержку проекта.
- Защиту от снятия компонента с производства.
- Оценку стоимости проекта по компонентам.
- Изготовление тестовой платы монтаж и пусконаладочные работы.



Тел: +7 (812) 336 43 04 (многоканальный)

Email: org@lifeelectronics.ru