



CTH Series

Capacitive Touch Sensor Display

15.0 x 15.0 x 11.0 mm



CTHS15CIC06 - Blue Capacitive Touch Sensor Through Hole with a Display Size of 0.59 x 0.59 inches (15 x 15 mm) square



Applications

- Mobile communication devices
- Electronic devices
- Point of sale Terminals
- Gaming
- Industrial control displays
- Touch Screen Monitors
- Portable Instruments
- Media Players
- Medical devices
- Appliances and consumer equipments

Key Features

- Integrated touch sensing and display technology
- Enables the device interface to be more user friendly and intuitive
- Mounting type: through hole (industry standard pitch 0.100")
- Available in one standard size: 15.0mm x 15.00mm x 11.00mm
- Available in 5 colors: super red, white, pure green, blue or yellow
- Touch sensor: integrated circuit (IC)
- Uniform illumination and high optical clarity due to LED technology
- Robust design due to no mechanical moving parts
- Simplifies devices design and manufacturability
- Optional overlay (icons): on/off, arrow, alarm
- Custom overlay icon can be manufactured upon request - contact VCC
- Compliant with RoHS and REACH requirements

Ordering Data

The CTH Series (Cap Touch) is available in a range of standard features and options. To specify your Cap Touch Display, simply choose one option from each column.

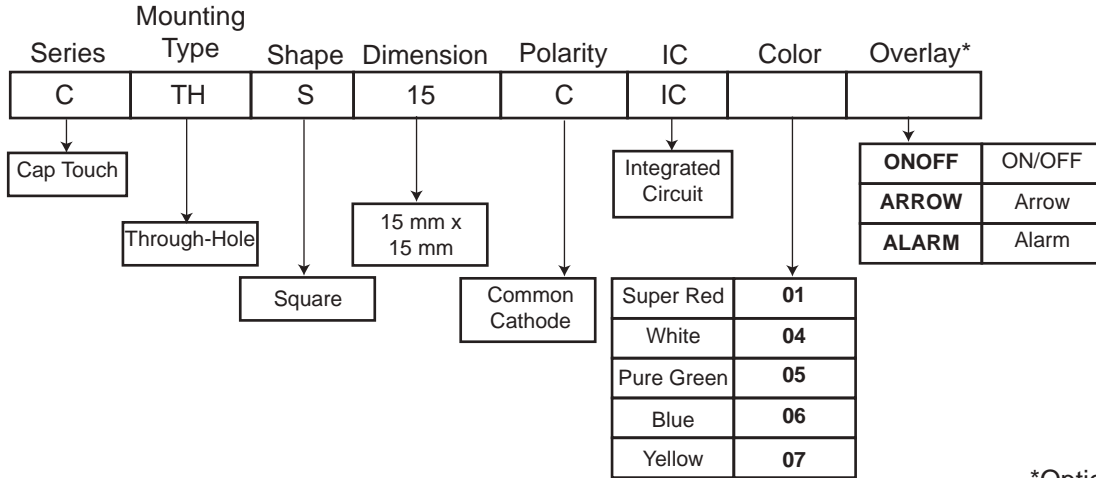



*Optional

Overlay

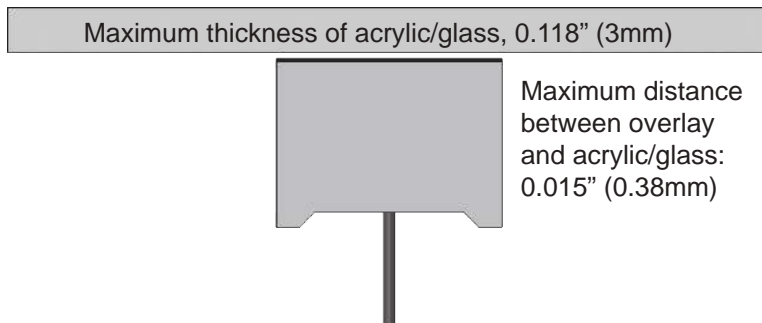
- Different LED colors can indicate the mode in which an electronic device is operating, depending on the icon associated with it.
- Optional graphic overlay made with polished LEXAN™ Polycarbonate 8010 Film 0.007" (0.175 mm) thick has reverse printed translucent white icon, in order to still see it even when the back lighting is off.
- Lexan 8010 is a transparent polycarbonate film and offers hardness, chemical and abrasion resistance, stiffness, and high temperature capability.
- Three standard icons are available: alarm, arrow and on-off. Custom icons are also available upon request.
- Capacitive Touch Display can also be mounted behind clear glass or plastic layer such as polycarbonate or acrylic, as shown in the picture below.



	Overlay On Off
	Overlay Arrow
	Overlay Alarm

Package Dimensions

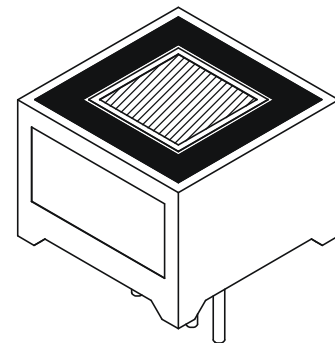
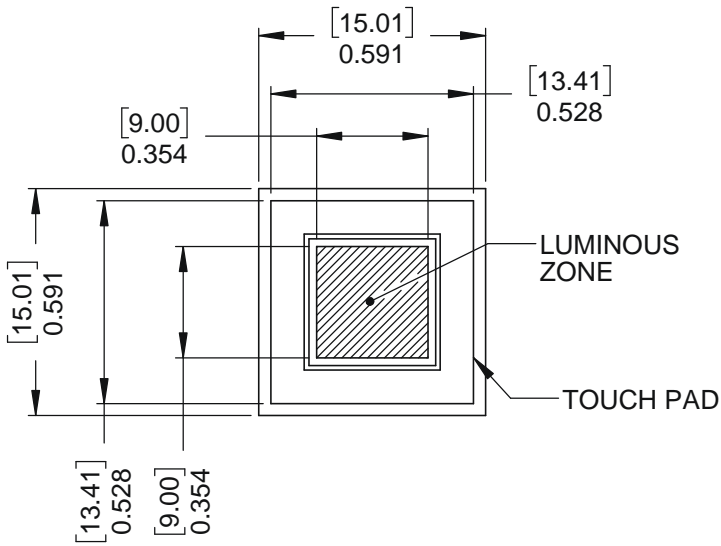
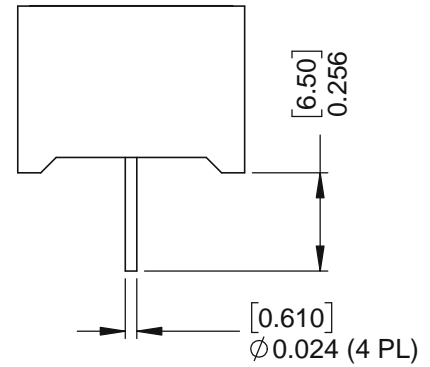
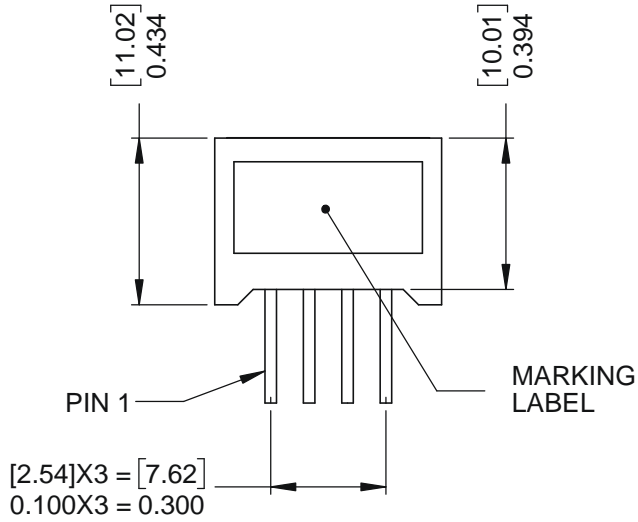

MARKING LABEL INFO

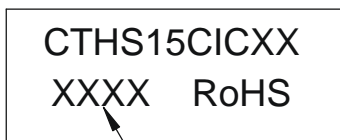

DATE CODE

Dimensions in [mm] inches
General tolerances unless otherwise specified:

	inches	mm
.X	$\pm .020$	$\pm .508$
.XX	$\pm .010$	$\pm .254$
.XXX	$\pm .005$	$\pm .127$

Internal Circuit Diagram

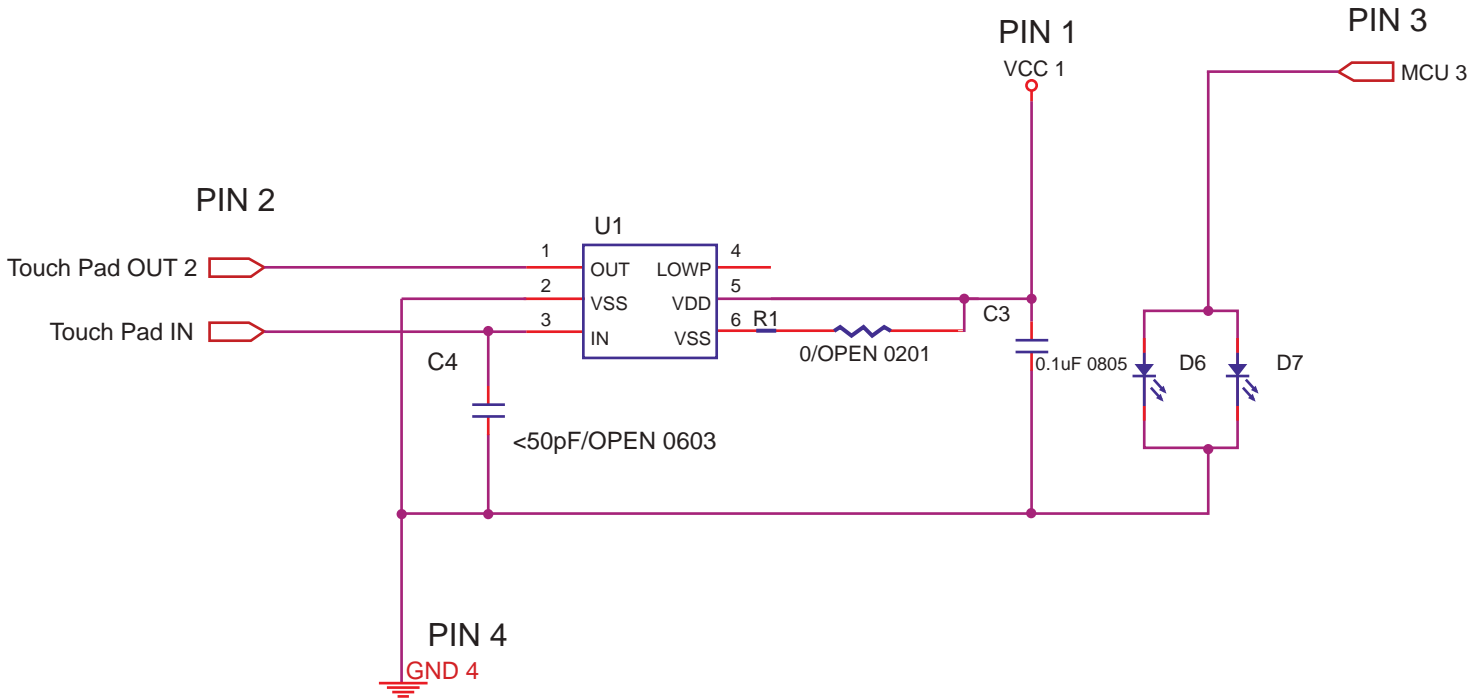

Internal IC Electrical Characteristics

(TA = 25°C, unless otherwise specified)

Symbol	Parameter	Condition	Min.	Typ.	Max.	Units.
VDD	Supply Voltage		2.0		5.5	V
VIH	High Level Input Voltage	@ VDD = 5V	0.7VDD		VDD	V
VIL	Low Level Input Voltage	@ VDD = 5V			0.3VDD	V
IDD1	Operating Current	@ VDD = 5V , no load		16		μA
		@ VDD = 3V , no load		3.5		
IDD2	Operating Current (SLRT=VDD)	@ VDD = 5V , no load		10.5		μA
		@ VDD = 3V , no load		2.5		
IOL	Low Level Output Current	@ VDD = 3V, VOL = 1V		30		mA
IOH	High Level Output Current	@ VDD = 3V, VOL = 2V		8		mA

Product Specifications

ABSOLUTE MAXIMUM RATING FOR LED

(Ta=25°C)

Parameter	Symbol	Rating	Unit
		Blue	
Power Dissipation Per Dice	PAD	114	mW
Derating Liner from 25°C per Dice	-	0.4	mA/°C
Continuous Forward Current Per Dice	IAF	30	mA
Peak Current Per Dice (duty cycle 1/10,1KHz)	IPF	100	mA
Reverse Voltage Per Dice	VR	5	V
Operating Temp.	Topr	-35 ~ +85	°C
Storage Temp.	Tstg	-35 ~ +85	°C

ELECTRO-OPTICAL CHARACTERISTICS

(Ta=25°C)

Parameter	Symbol	Min.	Typ.	Max.	Unit	Condition
Luminous Intensity	Iv	44	92	--	mcd	IF = 20 mA
Forward Voltage	VF	--	3.2	3.8	V	IF = 20 mA
Peak Emission Wavelength	λP	--	--	--	nm	IF = 20 mA
Dominant Wavelength	λD	--	470	--	nm	IF = 20 mA
Spectrum Radiation Bandwidth	Δλ	--	30	--	nm	IF = 20 mA
Luminous Intensity Matching Ratio	Iv-M	--	-	2 : 1	--	IF = 10 mA
Reverse Current	IR		-	50	μA	VR = 5V

Product Specifications

ELECTRICAL/OPTICAL CHARACTERISTICS CURVES

(Ta=25°C)

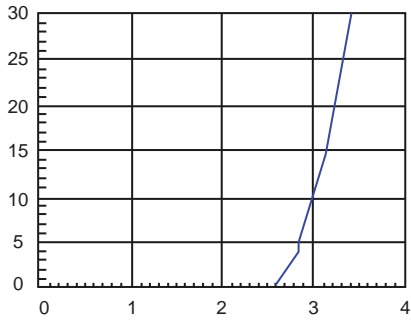

Forward Voltage (V)
Forward Current vs. Forward Voltage

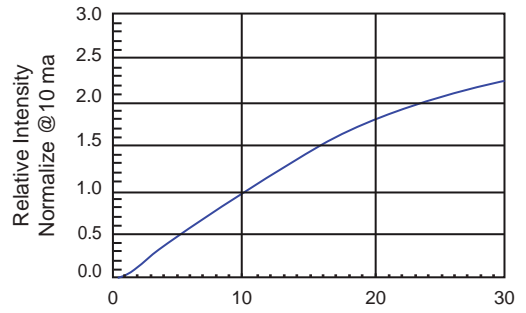

Forward Voltage (mA)
Relative Intensity vs. Forward Current

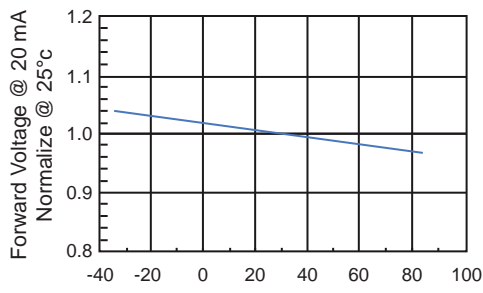

Ambient Temperature (°C)
Forward Voltage vs. Temperature

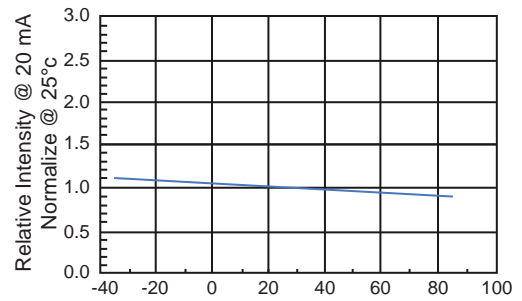

Ambient Temperature (°C)
Relative Intensity vs. Temperature

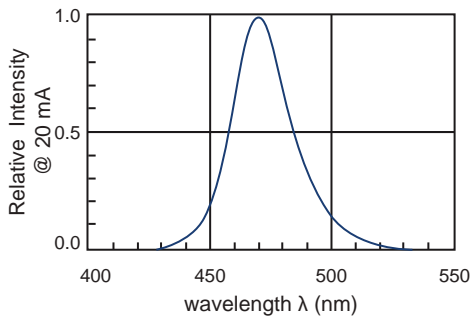

wavelength λ (nm)
Relative Intensity vs. Wavelength

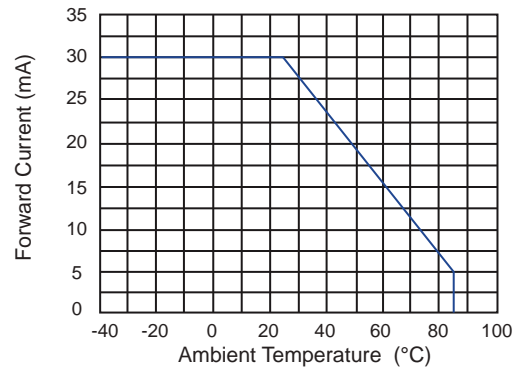

Ambient Temperature (°C)
Forward Current vs. Temperature

Product Specifications

SOLDERING CONDITIONS

1. Wave Soldering Profile

Distance: 1.6mm min (From Seating Plane)

Item	Condition		Note
Preheat	Temperature T1	80 – 120 °C	PWB Temperature (Soldering Side Surface)
	Time t1	60 – 180sec	
Solder Dip	Temperature T2	230 – 260°C	Bath Temperature
	Time t2	2 – 4 sec	Solder Tank Passage Time

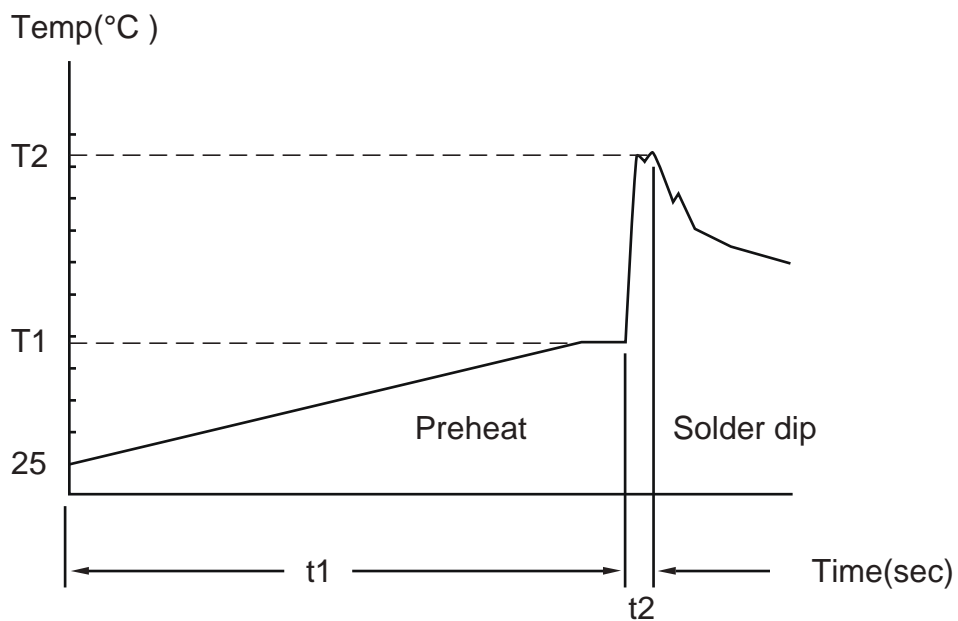

2. Hand Soldering (Iron Condition)

Soldering Iron: 30W Max

Temperature 350°C Max

Soldering Time: 3 Seconds Max (One Time)

Distance: 1.6mm min (From Seating Plane)

Application Circuit

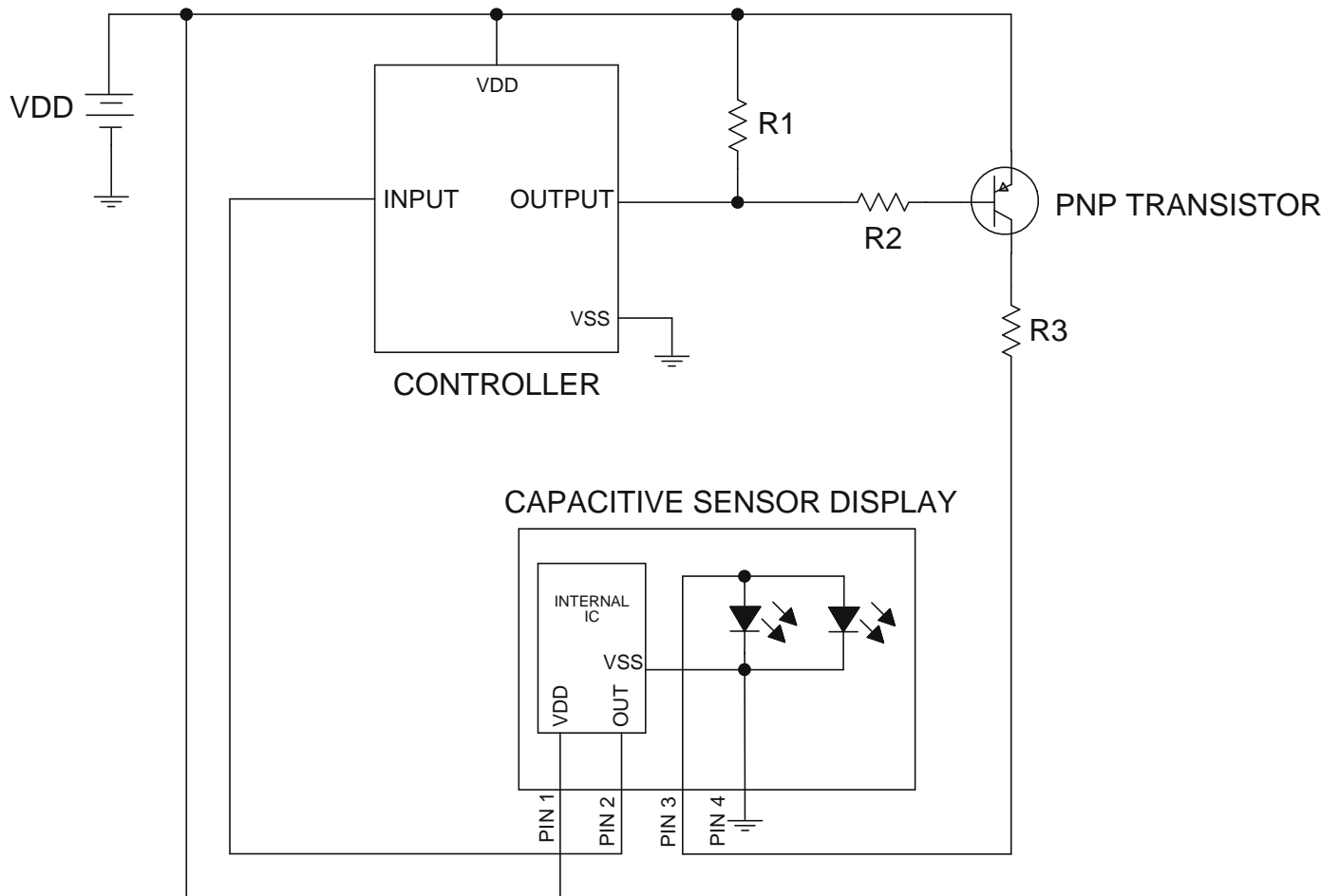

Compliances and Approvals



Компания «Life Electronics» занимается поставками электронных компонентов импортного и отечественного производства от производителей и со складов крупных дистрибьюторов Европы, Америки и Азии.

С конца 2013 года компания активно расширяет линейку поставок компонентов по направлению коаксиальный кабель, кварцевые генераторы и конденсаторы (керамические, пленочные, электролитические), за счёт заключения дистрибьюторских договоров

Мы предлагаем:

- Конкуренеспособные цены и скидки постоянным клиентам.
- Специальные условия для постоянных клиентов.
- Подбор аналогов.
- Поставку компонентов в любых объемах, удовлетворяющих вашим потребностям.
- Приемлемые сроки поставки, возможна ускоренная поставка.
- Доставку товара в любую точку России и стран СНГ.
- Комплексную поставку.
- Работу по проектам и поставку образцов.
- Формирование склада под заказчика.
- Сертификаты соответствия на поставляемую продукцию (по желанию клиента).
- Тестирование поставляемой продукции.
- Поставку компонентов, требующих военную и космическую приемку.
- Входной контроль качества.
- Наличие сертификата ISO.

В составе нашей компании организован Конструкторский отдел, призванный помогать разработчикам, и инженерам.

Конструкторский отдел помогает осуществить:

- Регистрацию проекта у производителя компонентов.
- Техническую поддержку проекта.
- Защиту от снятия компонента с производства.
- Оценку стоимости проекта по компонентам.
- Изготовление тестовой платы монтаж и пусконаладочные работы.



Тел: +7 (812) 336 43 04 (многоканальный)

Email: org@lifeelectronics.ru