

MPC8314E

PowerQUICC II Pro Processor

Hardware Specifications

This document provides an overview of the MPC8314E PowerQUICC™ II Pro processor features, including a block diagram showing the major functional components. The MPC8314E contains a core built on Power Architecture™ technology. It is a cost-effective, low-power, highly integrated host processor that addresses the requirements of several storage, consumer, and industrial applications, including main CPUs and I/O processors in network attached storage (NAS), voice over IP (VoIP) router/gateway, intelligent wireless LAN (WLAN), set top boxes, industrial controllers, and wireless access points. The MPC8314E extends the PowerQUICC II Pro family, adding higher CPU performance, new functionality, and faster interfaces while addressing the requirements related to time-to-market, price, power consumption, and package size. Note that while the MPC8314E supports a security engine, the MPC8314 does not.

Contents

1. Overview	2
2. MPC8314E Features	2
3. Electrical Characteristics	7
4. Power Characteristics	12
5. Clock Input Timing	13
6. RESET Initialization	15
7. DDR and DDR2 SDRAM	16
8. DUART	22
9. Ethernet: Three-Speed Ethernet, MII Management ..	22
10. USB	37
11. Local Bus	39
12. JTAG	42
13. I ² C	45
14. PCI	47
15. High-Speed Serial Interfaces (HSSI)	49
16. PCI Express	59
17. Timers	66
18. GPIO	67
19. IPIC	68
20. SPI	68
21. TDM	70
22. Package and Pin Listings	72
23. Clocking	85
24. Thermal	90
25. System Design Information	95
26. Ordering Information	98
27. Revision History	100

1 Overview

The MPC8314E incorporates the e300c3 (MPC603e-based) core, which includes 16 Kbytes of L1 instruction and data caches, on-chip memory management units (MMUs), and floating-point support. In addition to the e300 core, the SoC platform includes features such as dual enhanced three-speed 10, 100, 1000 Mbps Ethernet controllers (eTSECs) with SGMII support, a 32- or 16-bit DDR1/DDR2 SDRAM memory controller, a security engine to accelerate control and data plane security protocols, and a high degree of software compatibility with previous-generation PowerQUICC processor-based designs for backward compatibility and easier software migration. The MPC8314E also offers peripheral interfaces such as a 32-bit PCI interface with up to 66 MHz operation, 16-bit enhanced local bus interface with up to 66 MHz operation, TDM interface, and USB 2.0 with an on-chip USB 2.0 PHY.

8314E offers additional high-speed interconnect support with dual single-lane PCI Express interfaces. When not used for PCI Express, the SerDes interface may be configured to support SGMII. The MPC8314E security engine (SEC 3.3) allows CPU-intensive cryptographic operations to be offloaded from the main CPU core. This figure shows a block diagram of the MPC8314E.

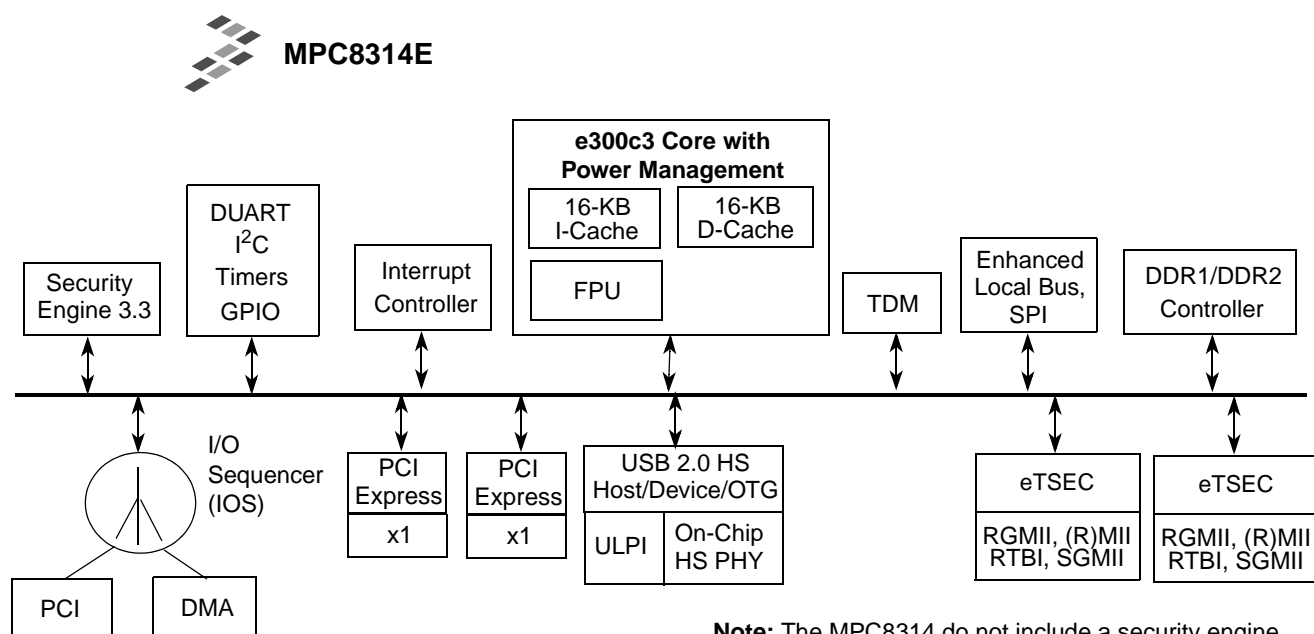

Figure 1. MPC8314E Block Diagram

2 MPC8314E Features

The following features are supported in the MPC8314E.

2.1 e300 Core

The e300 core has the following features:

- Operates at up to 400 MHz
- 16-Kbyte instruction cache, 16-Kbyte data cache

- One floating point unit and two integer units
- Software-compatible with the Freescale processor families implementing the PowerPC Architecture
- Performance monitor

2.2 Serial Interfaces

The following interfaces are supported in the MPC8314E.

- Two enhanced TSECs (eTSECs)
- Two Ethernet interfaces using one RGMII/MII/RMII/RTBI or SGMII (no GMII)
- Dual UART, one I²C, and one SPI interface

2.3 Security Engine

The security engine is optimized to handle all the algorithms associated with IPSec, 802.11i, and iSCSI. The security engine contains one crypto-channel, a controller, and a set of crypto execution units (EUs). The execution units are:

- Public key execution unit (PKEU)
 - RSA and Diffie-Hellman (to 4096 bits)
 - Programmable field size up to 2048 bits
 - Elliptic curve cryptography (1023 bits)
 - F2m and F(p) modes
 - Programmable field size up to 511 bits
- Data encryption standard execution unit (DEU)
 - DES, 3DES
 - Two key (K1, K2) or three key (K1, K2, K3)
 - ECB, CBC, CFB-64 and OFB-64 modes for both DES and 3DES
- Advanced encryption standard unit (AESU)
 - Implements the Rijndael symmetric key cipher
 - Key lengths of 128, 192, and 256 bits
 - ECB, CBC, CCM, CTR, GCM, CMAC, OFB, CFB, XCBC-MAC and LRW modes
 - XOR acceleration
- Message digest execution unit (MDEU)
 - SHA with 160-bit, 256-bit, 384-bit and 512-bit message digest
 - SHA-384/512
 - MD5 with 128-bit message digest
 - HMAC with either algorithm
- Random number generator (RNG)

- Combines a True Random Number Generator (TRNG) and a NIST-approved Pseudo-Random Number Generator (PRNG) (as described in Annex C of FIPS140-2 and ANSI X9.62).
- Cyclical Redundancy Check Hardware Accelerator (CRCA)
 - Implements CRC32C as required for iSCSI header and payload checksums, CRC32 as required for IEEE 802 packets, as well as for programmable 32 bit CRC polynomials

2.4 DDR Memory Controller

The DDR1/DDR2 memory controller includes the following features:

- Single 16- or 32-bit interface supporting both DDR1 and DDR2 SDRAM
- Support for up to 266 MHz data rate
- Support for two physical banks (chip selects), each bank independently addressable
- 64-Mbit to 2-Gbit (for DDR1) and to 4-Gbit (for DDR2) devices with x8/x16 data ports (no direct x4 support)
- Support for one 16-bit device or two 8-bit devices on a 16-bit bus or two 16-bit devices on a 32-bit bus
- Support for up to 16 simultaneous open pages
- Supports auto refresh
- On-the-fly power management using CKE
- 1.8-/2.5-V SSTL2 compatible I/O

2.5 PCI Controller

The PCI controller includes the following features:

- Designed to comply with *PCI Local Bus Specification Revision 2.3*
- Single 32-bit data PCI interface operates at up to 66 MHz
- PCI 3.3-V compatible (not 5-V compatible)
- Support for host and agent modes
- On-chip arbitration, supporting three external masters on PCI
- Selectable hardware-enforced coherency

2.6 TDM Interface

The TDM interface includes the following features:

- Independent receive and transmit with dedicated data, clock and frame sync line
- Separate or shared RCK and TCK whose source can be either internal or external
- Glueless interface to E1/T1 frames and MVIP, SCAS, and H.110 buses
- Up to 128 time slots, where each slot can be programmed to be active or inactive
- 8- or 16-bit word widths
- The TDM Transmitter Sync Signal (TFS), Transmitter Clock Signal (TCK) and Receiver Clock

- Signal (RCK) can be configured as either input or output
- Frame sync and data signals can be programmed to be sampled either on the rising edge or on the falling edge of the clock
- Frame sync can be programmed as active low or active high
- Selectable delay (0–3 bits) between the Frame Sync signal and the beginning of the frame
- MSB or LSB first support

2.7 USB Dual-Role Controller

The USB controller includes the following features:

- Designed to comply with *USB Specification, Rev. 2.0*
- Supports operation as a stand-alone USB device
 - Supports one upstream facing port
 - Supports three programmable USB endpoints
- Supports operation as a stand-alone USB host controller
 - Supports USB root hub with one downstream-facing port
 - Enhanced host controller interface (EHCI) compatible
- Supports high-speed (480 Mbps), full-speed (12 Mbps), and low-speed (1.5 Mbps) operation. Low-speed operation is supported only in host mode.
- Supports UTMI+ low pin interface (ULPI) or on-chip USB-2.0 full-speed/high-speed PHY
- Supports USB on-the-go mode, which includes both device and host functionality, when using an external ULPI PHY

2.8 Dual PCI Express Interfaces

The PCI Express interfaces have the following features:

- PCI Express 1.0a compatible
- x1 link width
- Selectable operation as root complex or endpoint
- Both 32- and 64-bit addressing
- 128-byte maximum payload size
- Support for MSI and INTx interrupt messages
- Virtual channel 0 only
- Selectable Traffic Class
- Full 64-bit decode with 32-bit wide windows
- Dedicated descriptor based DMA engine per interface with separate read and write channels

2.9 Dual Enhanced Three-Speed Ethernet Controllers (eTSECs)

The eTSECs include the following features:

- Two SGMII/RGMII/MII/RMII/RTBI interfaces
- Two controllers designed to comply with IEEE Std 802.3™, IEEE 802.3u™, IEEE 802.3x™, IEEE 802.3z™, IEEE 802.3au™, IEEE 802.3ab™, and IEEE Std 1588™
- Support for Wake-on-Magic Packet™, a method to bring the device from standby to full operating mode
- MII management interface for external PHY control and status.

2.10 Integrated Programmable Interrupt Controller (IPIC)

The integrated programmable interrupt controller (IPIC) provides a flexible solution for general-purpose interrupt control. The IPIC programming model is compatible with the MPC8260 interrupt controller and supports external and internal discrete interrupt sources. Interrupts can also be redirected to an external interrupt controller.

2.11 Power Management Controller (PMC)

The MPC8314E supports a range of power management states that significantly lower power consumption under the control of the power management controller. The PMC includes the following features:

- Provides power management when the device is used in both PCI host and agent modes
- PCI Power Management 1.2 D0, D1, D2, D3hot, and D3cold states
- PME generation in PCI agent mode, PME detection in PCI host mode
- Wake-up from Ethernet (magic packet), USB, GPIO, and PCI (PME input as host) while in the D1, D2 and D3hot states
- A new low-power standby power management state called D3warm
 - The PMC, one Ethernet port, and the GTM block remain powered via a split power supply controlled through an external power switch
 - Wake-up events include Ethernet (magic packet), GTM, GPIO, or IRQ inputs and cause the device to transition back to normal operation
 - PCI agent mode is not supported in D3warm state
- PCI Express-based PME events are not supported

2.12 Serial Peripheral Interface (SPI)

The serial peripheral interface (SPI) allows the MPC8314E to exchange data between other PowerQUICC family chips, Ethernet PHYs for configuration, and peripheral devices such as EEPROMs, real-time clocks, A/D converters, and ISDN devices.

The SPI is a full-duplex, synchronous, character-oriented channel that supports a four-wire interface (receive, transmit, clock, and slave select). The SPI block consists of transmitter and receiver sections, an independent baud-rate generator, and a control unit.

2.13 DMA Controller, I²C, DUART, Enhanced Local Bus Controller (eLBC), and Timers

The integrated four-channel DMA controller includes the following features:

- Allows chaining (both extended and direct) through local memory-mapped chain descriptors (accessible by local masters)
- Misaligned transfer capability for source/destination address
- Supports external DREQ, DACK and DONE signals

There is one I²C controller. This synchronous, multi-master buses can be connected to additional devices for expansion and system development.

The DUART supports full-duplex operation and is compatible with the PC16450 and PC16550 programming models. 16-byte FIFOs are supported for both the transmitter and the receiver.

The eLBC port allows connections with a wide variety of external DSPs and ASICs. Three separate state machines share the same external pins and can be programmed separately to access different types of devices. The general-purpose chip select machine (GPCM) controls accesses to asynchronous devices using a simple handshake protocol. The three user programmable machines (UPMs) can be programmed to interface to synchronous devices or custom ASIC interfaces. Each chip select can be configured so that the associated chip interface can be controlled by the GPCM or UPM controller. Both may exist in the same system. The local bus can operate at up to 66 MHz.

The system timers include the following features: periodic interrupt timer, real time clock, software watchdog timer, and two general-purpose timer blocks.

3 Electrical Characteristics

This section provides the AC and DC electrical specifications and thermal characteristics for the MPC8314E, which is currently targeted to these specifications. Some of these specifications are independent of the I/O cell, but they are included for complete reference. These are not purely I/O buffer design specifications.

3.1 Overall DC Electrical Characteristics

This section covers the ratings, conditions, and other characteristics.

3.1.1 Absolute Maximum Ratings

This table provides the absolute maximum ratings.

Table 1. Absolute Maximum Ratings¹

Characteristic	Symbol	Max Value	Unit	Note
Core supply voltage	VDD	-0.3 to 1.26	V	—
PLL supply voltage	AVDD	-0.3 to 1.26	V	—
DDR1 DRAM I/O supply voltage	GVDD	-0.3 to 2.7	V	—

Table 1. Absolute Maximum Ratings ¹ (continued)

Characteristic		Symbol	Max Value	Unit	Note
DDR2 DRAM I/O supply voltage		GVDD	-0.3 to 1.9	V	—
PCI, local bus, DUART, system control and power management, I ² C, Ethernet management, 1588 timer and JTAG I/O voltage		NVDD	-0.3 to 3.6	V	7
USB, and eTSEC I/O voltage		LVDD	-0.3 to 2.75 or -0.3 to 3.6	V	6, 8
PHY voltage	USB PHY	USB_PLL_PWR1	-0.3 to 1.26	V	—
		USB_PLL_PWR3, USB_VDDA_BIAS, VDDA	-0.3 to 3.6	V	—
	SERDES PHY	XCOREVDD, XPADVDD, SDAVDD	-0.3 to 1.26	V	—
Input voltage	DDR DRAM signals	MV _{IN}	-0.3 to (GVDD + 0.3)	V	2, 4
	DDR DRAM reference	MVREF	-0.3 to (GVDD + 0.3)	V	2, 4
	eTSEC signals	LV _{IN}	-0.3 to (LVDD + 0.3)	V	3, 4
	Local bus, DUART, SYS_CLK_IN, system control and power management, I ² C, and JTAG signals	NV _{IN}	-0.3 to (NVDD + 0.3)	V	3, 4
	PCI	NV _{IN}	-0.3 to (NVDD + 0.3)	V	5
Storage temperature range		T _{STG}	-55 to 150	°C	—

Note:

1. Functional and tested operating conditions are given in [Table 2](#). Absolute maximum ratings are stress ratings only, and functional operation at the maximums is not guaranteed. Stresses beyond those listed may affect device reliability or cause permanent damage to the device.
2. **Caution:** MV_{IN} must not exceed GVDD by more than 0.3 V. This limit may be exceeded for a maximum of 20 ms during power-on reset and power-down sequences.
3. **Caution:** (N,L)V_{IN} must not exceed (N,L)VDD by more than 0.3 V. This limit may be exceeded for a maximum of 20 ms during power-on reset and power-down sequences.
4. (M,N,L)V_{IN} and MVREF may overshoot/undershoot to a voltage and for a maximum duration as shown in [Figure 2](#).
5. NV_{IN} on the PCI interface may overshoot/undershoot according to the PCI Electrical Specification for 3.3-V operation, as shown in [Figure 2](#).
6. The max value of supply voltage should be selected based on the RGMII mode.
7. NVDD means NVDD1_OFF, NVDD1_ON, NVDD2_OFF, NVDD2_ON, NVDD3_OFF, NVDD4_OFF
8. LVDD means LVDD1_OFF and LVDD2_ON

3.1.2 Power Supply Voltage Specification

This table provides the recommended operating conditions for the MPC8314E. Note that the values in this table are the recommended and tested operating conditions. Proper device operation outside of these conditions is not guaranteed.

Table 2. Recommended Operating Conditions

Characteristic	Symbol	Recommended Value ¹	Unit	Status in D3 Warm mode	Note
SerDes internal digital power	XCOREVDD	1.0 ± 50 mv	V	Switched Off	—
SerDes internal digital power	XCOREVSS	0.0	V	—	—
SerDes I/O digital power	XPADVDD	1.0 ± 50 mv	V	Switched Off	—
SerDes I/O digital power	XPADVSS	0.0	V	—	—
SerDes analog power for PLL	SDAVDD	1.0 ± 50 mv	V	Switched Off	—
SerDes analog power for PLL	SDAVSS	0.0	V	—	—
Dedicated 3.3 V analog power for USB PLL	USB_PLL_PWR3	3.3 ± 165mv	V	Switched Off	—
Dedicated 1.0 V analog power for USB PLL	USB_PLL_PWR1	1.0 ± 50 mv	V	Switched Off	—
Dedicated analog ground for USB PLL	USB_PLL_GND	0.0	V	—	—
Dedicated USB power for USB bias circuit	USB_VDDA_BIAS	3.3 ± 300 mv	V	Switched Off	—
Dedicated USB ground for USB bias circuit	USB_VSSA_BIAS	0.0	V	—	—
Dedicated power for USB transceiver	USB_VDDA	3.3 ± 300 mv	V	Switched Off	—
Dedicated ground for USB transceiver	USB_VSSA	0.0	V	—	—
Core supply voltage	VDD	1.0 ± 50 mv	V	Switched Off	—
Core supply voltage	VDDC	1.0 ± 50 mv	V	Switched On	—
Analog power for e300 core APLL	AVDD1	1.0 ± 50 mv	V	Switched Off	6
Analog power for system APLL	AVDD2	1.0 ± 50 mv	V	Switched On	6
DDR and DDR2 DRAM I/O voltage	GVDD	2.5 ± 200 mv 1.8 ± 100 mv	V	Switched Off	—
Differential reference voltage for DDR and DDR2 controller	MVREF	GVDD /2	V	Switched Off	—
Standard I/O voltage	NVDD1_ON	3.3 ± 300 mv	V	Switched On	1
Standard I/O voltage	NVDD2_ON	3.3 ± 300 mv	V	Switched On	1
Standard I/O voltage	NVDD1_OFF	3.3 ± 300 mv	V	Switched Off	2
Standard I/O voltage	NVDD2_OFF	3.3 ± 300 mv	V	Switched Off	2
Standard I/O voltage	NVDD3_OFF	3.3 ± 300 mv	V	Switched Off	2
Standard I/O voltage	NVDD4_OFF	3.3 ± 300 mv	V	Switched Off	2
eTSEC/USBdr I/O supply	LVDD1_OFF	2.5 ± 125 mv 3.3 ± 300 mv	V	Switched Off	—
eTSEC I/O supply	LVDD2_ON	2.5 ± 125 mv 3.3 ± 300 mv	V	Switched On	—
Analog and digital ground	VSS	0.0	V	—	—
Junction temperature range	T _A /T _J	0 to 105	°C	—	3

Table 2. Recommended Operating Conditions (continued)

Characteristic	Symbol	Recommended Value ¹	Unit	Status in D3 Warm mode	Note
----------------	--------	--------------------------------	------	------------------------	------

Note:

1. The NVDDx_ON are static power supplies and can be connected together.
2. The NVDDx_OFF are switchable power supplies and can be connected together.
3. Minimum Temperature is specified with T_A ; maximum temperature is specified with T_J .
4. All Power rails must be connected and power applied to the MPC8314 even if the IP interfaces are not used.
5. All I/O pins should be interfaced with peripherals operating at same voltage level.
6. This voltage is the input to the filter discussed in [Section 25.2, "PLL Power Supply Filtering"](#) and not necessarily the voltage at the AVDD pin.
7. All 1V power supplies should be derived from the same source.

This figure shows the overshoot and undershoot voltages at the interfaces of the MPC8314E.

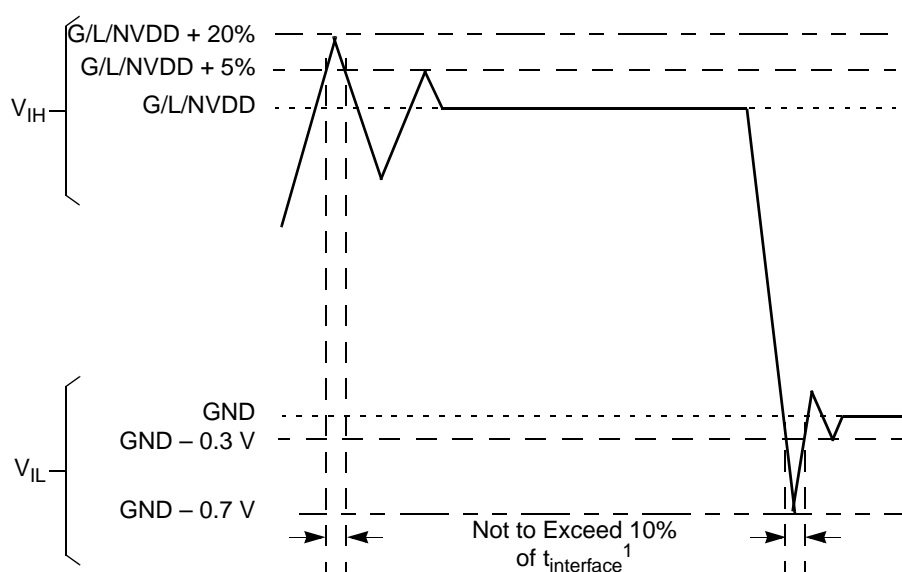
Note:

1. $t_{\text{interface}}$ refers to the clock period associated with the bus clock interface.

Figure 2. Overshoot/Undershoot Voltage for GVDD/NVDD/LVDD

3.1.3 Output Driver Characteristics

This table provides information on the characteristics of the output driver strengths. The values are preliminary estimates.

Table 3. Output Drive Capability

Driver Type	Output Impedance (Ω)	Supply Voltage
Local bus interface utilities signals	42	NVDD = 3.3 V
PCI signals	25	
DDR signal ¹	18	GVDD = 2.5 V
DDR2 signal 1	18	GVDD = 1.8 V

Table 3. Output Drive Capability (continued)

Driver Type	Output Impedance (Ω)	Supply Voltage
DUART, system control, I ² C, JTAG, SPI	42	NVDD = 3.3 V
GPIO signals	42	NVDD = 3.3 V
eTSEC	42	LVDD = 3.3 V / 2.5 V

¹ Output Impedance can also be adjusted through configurable options in DDR Control Driver Register (DDRCDR). See the *MPC8315E PowerQUICC II Pro Integrated Host Processor Family Reference Manual*.

3.2 Power Sequencing

The MPC8314E does not require the core supply voltage (VDD and VDDC) and I/O supply voltages (GVDD, LVDDx_ON, LVDDx_OFF, NVDDx_ON and NVDDx_OFF) to be applied in any particular order. During the power ramp up, before the power supplies are stable, if the I/O voltages are supplied before the core voltage, there may be a period of time when all input and output pins be actively driven and cause contention and/or excessive current. In order to avoid actively driving the I/O pins and to eliminate excessive current draw, apply the continuous core voltage (VDDC) before the continuous I/O voltages (LVDDx_ON and NVDDx_ON) and switchable core voltage (VDD) before the switchable I/O voltages (GVDD, LVDDx_OFF, and NVDDx_OFF). PORESET should be asserted before the continuous power supplies fully ramp up. In the case where the core voltage is applied first, the core voltage supply must rise to 90% of its nominal value before the I/O supplies reach 0.7 V, see Figure 3. Once all the power supplies are stable, wait for a minimum of 32 clock cycles before negating PORESET.

The I/O power supply ramp-up slew rate should be slower than 4V/100 μ s, this requirement is for ESD circuit.

This figure shows the power-up sequencing for switchable and continuous supplies.

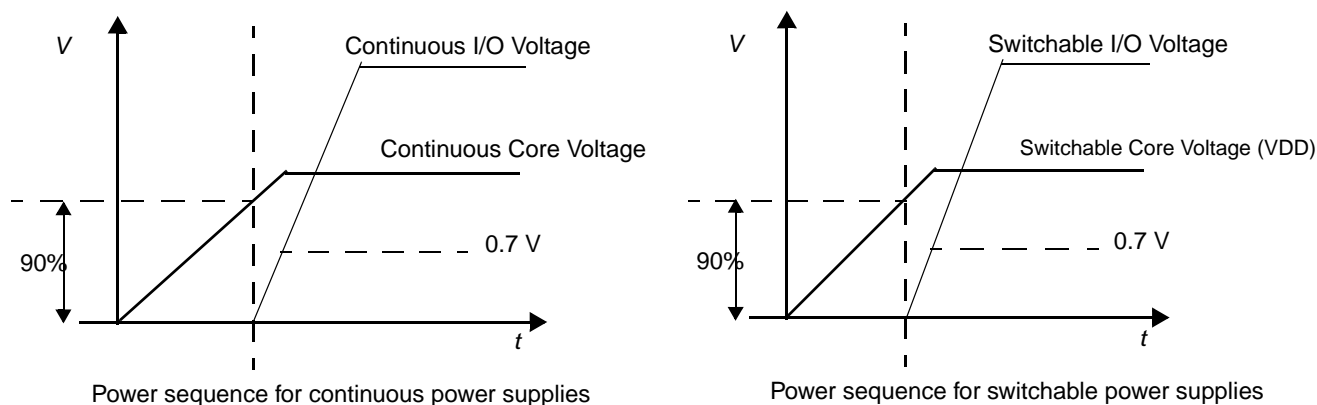
Figure 3. Power-Up Sequencing

When switching from normal mode to D3 warm (standby) mode, first turn off the switchable I/O voltage supply and then turn off the switchable core voltage supply. Similarly, when switching from D3 warm (standby) mode to normal mode, first turn on the switchable core voltage supply and then turn on the switchable I/O voltage supply.

CAUTION

When the device is in D3 warm (standby) mode, all external voltage supplies applied to any I/O pins, with the exception of wake-up pins, must be turned off. Applying supplied external voltage to any I/O pins, except the wake up pins, while the device is in D3 warm standby mode may cause permanent damage to the device.

An example of the power-up sequencing is shown in Figure 4 when implemented along with low power D3 warm mode.

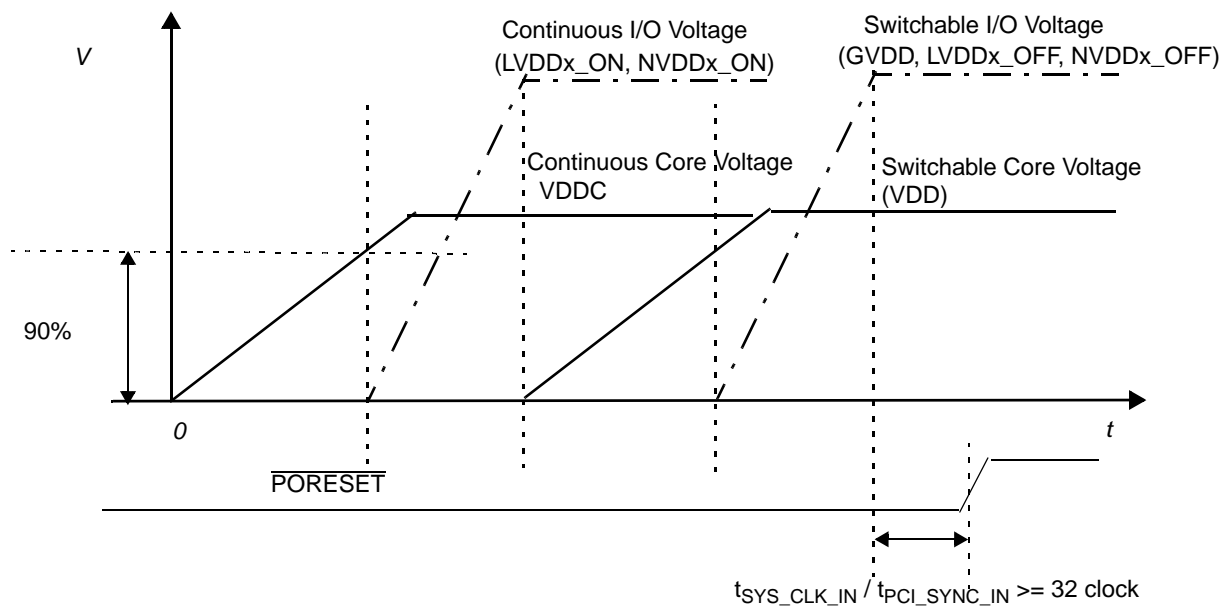

Figure 4. Power Up Sequencing Example with Low power D3 Warm Mode

4 Power Characteristics

This table shows the estimated typical power dissipation for this family of devices.

Table 4. MPC8314E Power Dissipation

(Does not include I/O power dissipation)

Core Frequency (MHz)	CSB Frequency (MHz)	Typical ^{1,3}	Maximum ^{1,2}	Unit
266	133	1.116	1.646	W
333	133	1.142	1.665	W
400	133	1.167	1.690	W

Note:

1. The values do not include I/O supply power, but do include core, AVDD, USB PLL, and digital SerDes power.
2. Maximum power is based on a voltage of $V_{dd} = 1.05V$, a junction temperature of $T_j = 105^{\circ}C$, and an artificial smoker test.
3. Typical power is based on a voltage of $V_{dd} = 1.05V$, and an artificial smoker test running at room temperature.

This table shows the estimated typical I/O power dissipation for this family of devices.

Table 5. MPC8314E Power Dissipation

Interface	Frequency	$G_{V_{DD}}$ (1.8 V)	$G_{V_{DD}}$ (2.5 V)	$N_{V_{DD}}$ (3.3 V)	LVDD1_OFF/ LVDD2_ON (3.3V)	LVDD2 _ON (3.3V)	VDD33PLL, VDD33ANA (3.3V)	SATA_VDD, VDD1IO, VDD1ANA (1.0V)	XCOREVDD, XPADVDD, SDAVDD (1.0V)	Unit
DDR 1 Rs = 22Ω Rt = 50Ω	266MHz, 32 bits	—	0.323	—	—	—	—	—	—	W
	200MHz, 32 bits	—	0.291	—	—	—	—	—	—	W
DDR 2 Rs = 22Ω Rt = 75Ω	266MHz, 32 bits	0.246	—	—	—	—	—	—	—	W
	200MHz, 32bits	0.225	—	—	—	—	—	—	—	W
PCI I/O load = 50pF	33 MHz	—	—	0.120	—	—	—	—	—	W
	66 MHz	—	—	0.249	—	—	—	—	—	W
Local bus I/O load = 20pF	66 MHz	—	—	—	—	0.056	—	—	—	W
	50 MHz	—	—	—	—	0.040	—	—	—	W
eTSEC I/O load = 20pF Multiple by number of interface used	MII, 25MHz	—	—	—	0.008	—	—	—	—	W
	RGMII, 125MHz (3.3V)	—	—	—	0.078	—	—	—	—	W
	RGMII, 125MHz (2.5V)	—	—	—	0.044	—	—	—	—	W
USBDR Controller (ULPI mode) load =20pF	60 MHz	—	—	—	0.078	—	—	—	—	W
USBDR+ Internal PHY (UTMI mode)	480 MHz	—	—	—	0.274	—	—	—	—	W
PCI Express two x1lane	2.5 GHz	—	—	—	—	—	—	—	0.190	W
Other I/O	—	—	—	0.015	—	—	—	—	—	W

5 Clock Input Timing

This section provides the clock input DC and AC electrical characteristics for the MPC8314E.

5.1 DC Electrical Characteristics

This table provides the clock input (SYS_CLK_IN/PCI_SYNC_IN) DC timing specifications for the MPC8314E.

Table 6. SYS_CLK_IN DC Electrical Characteristics

Parameter	Condition	Symbol	Min	Max	Unit
Input high voltage	—	V_{IH}	2.4	$NVDD + 0.3$	V
Input low voltage	—	V_{IL}	-0.3	0.4	V
SYS_CLK_IN input current	$0\text{ V} \leq V_{IN} \leq NVDD$	I_{IN}	—	± 10	μA
SYS_XTAL_IN input current	$0\text{ V} \leq V_{IN} \leq NVDD$	I_{IN}	—	± 40	μA
PCI_SYNC_IN input current	$0\text{ V} \leq V_{IN} \leq NVDD$	I_{IN}	—	± 10	μA
RTC_CLK input current	$0\text{ V} \leq V_{IN} \leq NVDD$	I_{IN}	—	± 10	μA
USB_CLK_IN input current	$0\text{ V} \leq V_{IN} \leq NVDD$	I_{IN}	—	± 10	μA
USB_XTAL_IN input current	$0\text{ V} \leq V_{IN} \leq NVDD$	I_{IN}	—	± 40	μA

5.2 AC Electrical Characteristics

The primary clock source for the MPC8314E can be one of two inputs, SYS_CLK_IN or PCI_CLK, depending on whether the device is configured in PCI host or PCI agent mode. This table provides the clock input (SYS_CLK_IN/PCI_CLK) AC timing specifications for the MPC8314E.

Table 7. SYS_CLK_IN AC Timing Specifications

Parameter/Condition	Symbol	Min	Typical	Max	Unit	Note
SYS_CLK_IN/PCI_CLK frequency	$f_{\text{SYS_CLK_IN}}$	24	—	66.67	MHz	1, 6, 7
SYS_CLK_IN/PCI_CLK cycle time	$t_{\text{SYS_CLK_IN}}$	15	—	41.6	ns	6
SYS_CLK_IN rise and fall time	t_{KH}, t_{KL}	0.6	—	4	ns	2, 6
PCI_CLK rise and fall time	t_{PCH}, t_{PCL}	0.6	0.8	1.2	ns	2
SYS_CLK_IN/PCI_CLK duty cycle	$t_{KHK}/t_{\text{SYS_CLK_IN}}$	40	—	60	%	3, 6
SYS_CLK_IN/PCI_CLK jitter	—	—	—	± 150	ps	4, 5, 6

Note:

- Caution:** The system, core, and security block must not exceed their respective maximum or minimum operating frequencies.
- Rise and fall times for SYS_CLK_IN/PCI_CLK are specified at 20% to 80% of signal swing.
- Timing is guaranteed by design and characterization.
- This represents the total input jitter—short term and long term—and is guaranteed by design.
- The SYS_CLK_IN/PCI_CLK driver's closed loop jitter bandwidth should be <500 kHz at -20 dB. The bandwidth must be set low to allow cascade-connected PLL-based devices to track SYS_CLK_IN drivers with the specified jitter.
- The parameter names PCI_CLK and PCI_SYNC_IN are used interchangeably in this document.
- Spread spectrum is allowed up to 1% down-spread at 33kHz.(max. rate).

6 RESET Initialization

This section describes the DC and AC electrical specifications for the reset initialization timing and electrical requirements of the MPC8314E.

6.1 RESET DC Electrical Characteristics

This table provides the DC electrical characteristics for the RESET pins of the MPC8314E.

Table 8. RESET Pins DC Electrical Characteristics

Characteristic	Symbol	Condition	Min	Max	Unit
Input high voltage	V_{IH}	—	2.0	NVDD + 0.3	V
Input low voltage	V_{IL}	—	-0.3	0.8	V
Input current	I_{IN}	$0 V \leq V_{IN} \leq NVDD$	—	± 5	μA
Output high voltage	V_{OH}	$I_{OH} = -8.0 \text{ mA}$	2.4	—	V
Output low voltage	V_{OL}	$I_{OL} = 8.0 \text{ mA}$	—	0.5	V
Output low voltage	V_{OL}	$I_{OL} = 3.2 \text{ mA}$	—	0.4	V

6.2 RESET AC Electrical Characteristics

This table provides the reset initialization AC timing specifications of the MPC8314E.

Table 9. RESET Initialization Timing Specifications

Parameter/Condition	Min	Max	Unit	Note
Required assertion time of \overline{HRESET} to activate reset flow	32	—	$t_{PCI_SYNC_IN}$	1
Required assertion time of $\overline{PORESET}$ with stable clock applied to SYS_CLK_IN when the device is in PCI host mode	32	—	$t_{SYS_CLK_IN}$	2
Required assertion time of $\overline{PORESET}$ with stable clock applied to PCI_SYNC_IN when the device is in PCI agent mode	32	—	$t_{PCI_SYNC_IN}$	1
\overline{HRESET} assertion (output)	512	—	$t_{PCI_SYNC_IN}$	1
Input setup time for POR configuration signals (CFG_RESET_SOURCE[0:3] and CFG_SYS_CLKIN_DIV) with respect to negation of $\overline{PORESET}$ when the device is in PCI host mode	4	—	$t_{SYS_CLK_IN}$	2, 4
Input setup time for POR configuration signals (CFG_RESET_SOURCE[0:3] and CFG_SYS_CLKIN_DIV) with respect to negation of $\overline{PORESET}$ when the device is in PCI agent mode	4	—	$t_{PCI_SYNC_IN}$	1
Input hold time for POR configuration signals with respect to negation of \overline{HRESET}	0	—	ns	—
Time for the device to turn off POR configuration signals with respect to the assertion of \overline{HRESET}	—	4	ns	3
Time for the device to turn on POR config signals with respect to the negation of \overline{HRESET}	1	—	$t_{PCI_SYNC_IN}$	1, 3

Table 9. RESET Initialization Timing Specifications (continued)

Note:

1. $t_{\text{PCI_SYNC_IN}}$ is the clock period of the input clock applied to PCI_SYNC_IN. When the device is in PCI host mode the primary clock is applied to the SYS_CLK_IN input, and PCI_SYNC_IN period depends on the value of CFG_SYS_CLKIN_DIV.
2. $t_{\text{SYS_CLK_IN}}$ is the clock period of the input clock applied to SYS_CLK_IN. It is only valid when the device is in PCI host mode.
3. POR configuration signals consists of CFG_RESET_SOURCE[0:3] and CFG_SYS_CLKIN_DIV.
4. The parameter names CFG_SYS_CLKIN_DIV and CFG_CLKIN_DIV are used interchangeably in this document.

This table provides the PLL lock times.

Table 10. PLL Lock Times

Parameter/Condition	Min	Max	Unit	Note
System PLL lock times	—	100	μs	—
e300 core PLL lock times	—	100	μs	—
SerDes (SGMII/PCI Exp Phy) PLL lock times	—	100	μs	—
USB phy PLL lock times	—	100	μs	—

7 DDR and DDR2 SDRAM

This section describes the DC and AC electrical specifications for the DDR SDRAM interface of the MPC8314E. Note that DDR SDRAM is $GVDD(\text{typ}) = 2.5 \text{ V}$ and DDR2 SDRAM is $GVDD(\text{typ}) = 1.8 \text{ V}$.

7.1 DDR and DDR2 SDRAM DC Electrical Characteristics

This table provides the recommended operating conditions for the DDR2 SDRAM component(s) of the MPC8314E when $GVDD(\text{typ}) = 1.8 \text{ V}$.

Table 11. DDR2 SDRAM DC Electrical Characteristics for $GVDD(\text{typ}) = 1.8 \text{ V}$

Parameter/Condition	Symbol	Min	Max	Unit	Note
I/O supply voltage	GVDD	1.7	1.9	V	1
I/O reference voltage	MVREF	$0.49 \times GVDD$	$0.51 \times GVDD$	V	2
I/O termination voltage	V_{TT}	$MVREF - 0.04$	$MVREF + 0.04$	V	3
Input high voltage	V_{IH}	$MVREF + 0.125$	$GVDD + 0.3$	V	—
Input low voltage	V_{IL}	-0.3	$MVREF - 0.125$	V	—
Output leakage current	I_{OZ}	-9.9	9.9	μA	4
Output high current ($V_{\text{OUT}} = 1.420 \text{ V}$, $GVDD = 1.7\text{V}$)	I_{OH}	-13.4	—	mA	—
Output low current ($V_{\text{OUT}} = 0.280 \text{ V}$)	I_{OL}	13.4	—	mA	—

Note:

1. GVDD is expected to be within 50 mV of the DRAM GVDD at all times.
2. MVREF is expected to be equal to $0.5 \times GVDD$, and to track GVDD DC variations as measured at the receiver. Peak-to-peak noise on MVREF may not exceed $\pm 2\%$ of the DC value.
3. V_{TT} is not applied directly to the device. It is the supply to which far end signal termination is made and is expected to be equal to MVREF. This rail should track variations in the DC level of MVREF.
4. Output leakage is measured with all outputs disabled, $0 \text{ V} \leq V_{\text{OUT}} \leq GVDD$.

This table provides the DDR2 capacitance when $GVDD(\text{typ}) = 1.8 \text{ V}$.

Table 12. DDR2 SDRAM Capacitance for $GVDD(\text{typ}) = 1.8 \text{ V}$

Parameter/Condition	Symbol	Min	Max	Unit	Note
Input/output capacitance: DQ, DQS	C_{IO}	6	8	pF	1
Delta input/output capacitance: DQ, DQS	C_{DIO}	—	0.5	pF	1

Note:

1. This parameter is sampled. $GVDD = 1.8 \text{ V} \pm 0.090 \text{ V}$, $f = 1 \text{ MHz}$, $T_A = 25^\circ\text{C}$, $V_{OUT} = GVDD/2$, V_{OUT} (peak-to-peak) = 0.2 V.

This table provides the recommended operating conditions for the DDR SDRAM component(s) of the MPC8314E when $GVDD(\text{typ}) = 2.5 \text{ V}$.

Table 13. DDR SDRAM DC Electrical Characteristics for $GVDD(\text{typ}) = 2.5 \text{ V}$

Parameter/Condition	Symbol	Min	Max	Unit	Note
I/O supply voltage	GVDD	2.3	2.7	V	1
I/O reference voltage	MVREF	$0.49 \times GVDD$	$0.51 \times GVDD$	V	2
I/O termination voltage	V_{TT}	$MVREF - 0.04$	$MVREF + 0.04$	V	3
Input high voltage	V_{IH}	$MVREF + 0.15$	$GVDD + 0.3$	V	—
Input low voltage	V_{IL}	-0.3	$MVREF - 0.15$	V	—
Output leakage current	I_{OZ}	-9.9	-9.9	μA	4
Output high current ($V_{OUT} = 1.95 \text{ V}$, $GVDD = 2.3 \text{ V}$)	I_{OH}	-16.2	—	mA	—
Output low current ($V_{OUT} = 0.35 \text{ V}$)	I_{OL}	16.2	—	mA	—

Note:

1. GVDD is expected to be within 50 mV of the DRAM GVDD at all times.
2. MVREF is expected to be equal to $0.5 \times GVDD$, and to track GVDD DC variations as measured at the receiver. Peak-to-peak noise on MVREF may not exceed $\pm 2\%$ of the DC value.
3. V_{TT} is not applied directly to the device. It is the supply to which far end signal termination is made and is expected to be equal to MVREF. This rail should track variations in the DC level of MVREF.
4. Output leakage is measured with all outputs disabled, $0 \text{ V} \leq V_{OUT} \leq GVDD$.

This table provides the DDR capacitance when $GVDD(\text{typ}) = 2.5 \text{ V}$.

Table 14. DDR SDRAM Capacitance for $GVDD(\text{typ}) = 2.5 \text{ V}$ Interface

Parameter/Condition	Symbol	Min	Max	Unit	Note
Input/output capacitance: DQ, DQS	C_{IO}	6	8	pF	1
Delta input/output capacitance: DQ, DQS	C_{DIO}	—	0.5	pF	1

Note:

1. This parameter is sampled. $GVDD = 2.5 \text{ V} \pm 0.125 \text{ V}$, $f = 1 \text{ MHz}$, $T_A = 25^\circ\text{C}$, $V_{OUT} = GVDD/2$, V_{OUT} (peak-to-peak) = 0.2 V.

This table provides the current draw characteristics for MV_{REF} .

Table 15. Current Draw Characteristics for MV_{REF}

Parameter / Condition	Symbol	Min	Max	Unit	Note
Current draw for MV_{REF}	I_{MVREF}	—	500	μA	1

Table 15. Current Draw Characteristics for MV_{REF}

Parameter / Condition	Symbol	Min	Max	Unit	Note
-----------------------	--------	-----	-----	------	------

Note:

1. The voltage regulator for MV_{REF} must be able to supply up to 500 μ A current.

7.2 DDR and DDR2 SDRAM AC Electrical Characteristics

This section provides the AC electrical characteristics for the DDR and DDR2 SDRAM interface.

7.2.1 DDR and DDR2 SDRAM Input AC Timing Specifications

This table lists the input AC timing specifications for the DDR2 SDRAM ($GVDD(\text{typ}) = 1.8 \text{ V}$).

Table 16. DDR2 SDRAM Input AC Timing Specifications for 1.8-V Interface

At recommended operating conditions with $GVDD$ of $1.8\text{V} \pm 100 \text{ mV}$

Parameter	Symbol	Min	Max	Unit	Note
AC input low voltage	V_{IL}	—	$MV_{REF} - 0.45$	V	—
AC input high voltage	V_{IH}	$MV_{REF} + 0.45$	—	V	—

This table lists the input AC timing specifications for the DDR SDRAM when $GVDD(\text{typ})=2.5 \text{ V}$.

Table 17. DDR SDRAM Input AC Timing Specifications for 2.5 V Interface

At recommended operating conditions with $GVDD$ of $2.5\text{V} \pm 200 \text{ mV}$

Parameter	Symbol	Min	Max	Unit	Note
AC input low voltage	V_{IL}	—	$MV_{REF} - 0.51$	V	
AC input high voltage	V_{IH}	$MV_{REF} + 0.51$	—	V	

The following two tables list the input AC timing specifications for the DDR SDRAM interface.

Table 18. DDR2 SDRAM Input AC Timing Specifications

At recommended operating conditions with $GVDD$ of $(1.8 \text{ V} \pm 100 \text{ mV})$

Parameter	Symbol	Min	Max	Unit	Note
Controller Skew for MDQS—MDQ	t_{CISKEW}	—875 —1250	875 1250	ps	1, 2, 3

Note:

1. t_{CISKEW} represents the total amount of skew consumed by the controller between MDQS[n] and any corresponding bit to be captured with MDQS[n]. This should be subtracted from the total timing budget.
2. The amount of skew that can be tolerated from MDQS to a corresponding MDQ signal is called t_{DISKEW} . This can be determined by the following equation: $t_{DISKEW} = \pm(T/4 - \text{abs}(t_{CISKEW}))$ where T is the clock period and $\text{abs}(t_{CISKEW})$ is the absolute value of t_{CISKEW} .
3. Memory controller ODT value of 150 Ω is recommended.

Table 19. DDR SDRAM Input AC Timing Specifications

At recommended operating conditions with $GVDD$ of $(2.5\text{V} \pm 200 \text{ mV})$

Parameter	Symbol	Min	Max	Unit	Note
-----------	--------	-----	-----	------	------

Table 19. DDR SDRAM Input AC Timing Specifications

At recommended operating conditions with GVDD of (2.5V ± 200 mV)

Controller Skew for MDQS—MDQ	266 MHz 200 MHz	t_{CISKEW}	-750 -1250	750 1250	ps	1, 2
------------------------------	--------------------	--------------	---------------	-------------	----	------

Note:

1. t_{CISKEW} represents the total amount of skew consumed by the controller between MDQS[n] and any corresponding bit to be captured with MDQS[n]. This should be subtracted from the total timing budget.
2. The amount of skew that can be tolerated from MDQS to a corresponding MDQ signal is called t_{DISKEW} . This can be determined by the following equation: $t_{DISKEW} = \pm(T/4 - \text{abs}(t_{CISKEW}))$ where T is the clock period and $\text{abs}(t_{CISKEW})$ is the absolute value of t_{CISKEW} .

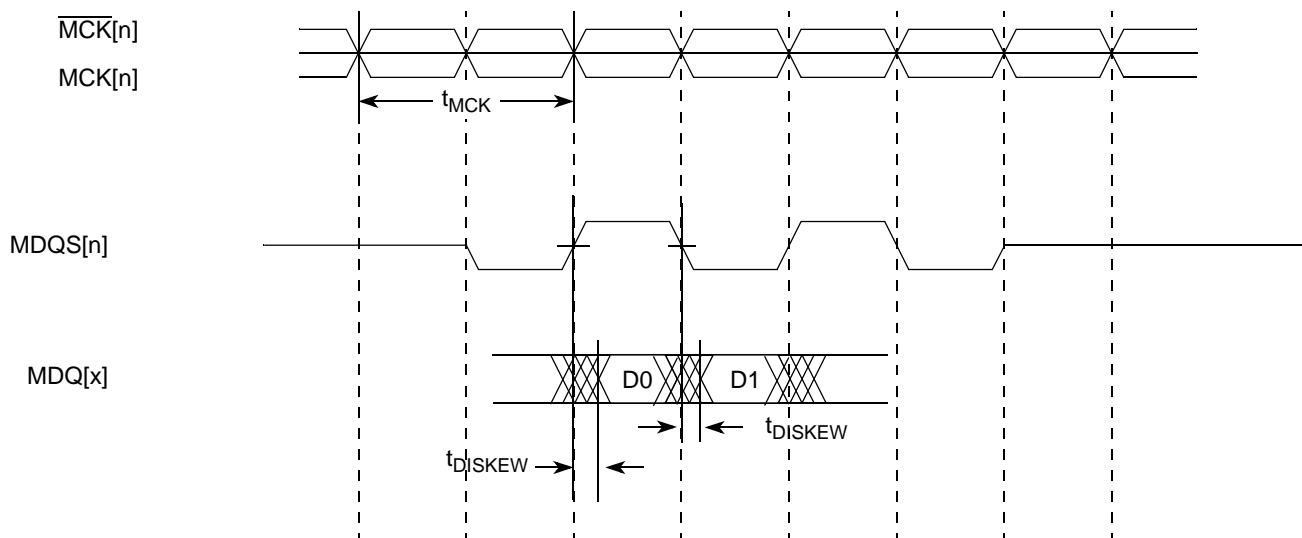
 This figure shows the DDR SDRAM input AC timing for the tolerated MDQS to MDQ skew (t_{DISKEW})

Figure 5. Timing Diagram for t_{DISKEW}

7.2.2 DDR and DDR2 SDRAM Output AC Timing Specifications

Table 20. DDR and DDR2 SDRAM Output AC Timing Specifications

At recommended operating conditions

Parameter	Symbol ¹	Min	Max	Unit	Note
MCK[n] cycle time at MCK[n]/ $\overline{\text{MCK}}[n]$ crossing	t_{MCK}	7.5	10	ns	2
ADDR/CMD output setup with respect to MCK 266 MHz 200 MHz	t_{DDKHAS}	2.9 3.5	— —	ns	3
ADDR/CMD output hold with respect to MCK 266 MHz 200 MHz	t_{DDKHAX}	3.15 4.20	— —	ns	3
$\overline{\text{MCS}}[n]$ output setup with respect to MCK 266 MHz 200 MHz	t_{DDKHCS}	3.15 4.20	— —	ns	3

Table 20. DDR and DDR2 SDRAM Output AC Timing Specifications (continued)

At recommended operating conditions

Parameter	Symbol ¹	Min	Max	Unit	Note
MCS[n] output hold with respect to MCK 266 MHz 200 MHz	t_{DDKHGX}	3.15 4.20	— —	ns	3
MCK to MDQS Skew	t_{DDKHMH}	-0.6	0.6	ns	4
MDQ//MDM output setup with respect to MDQS 266 MHz 200 MHz	t_{DDKHDS} , t_{DDKLDS}	900 1000	— —	ps	5
MDQ//MDM output hold with respect to MDQS 266 MHz 200 MHz	t_{DDKHDX} , t_{DDKLDX}	1100 1200	— —	ps	5
MDQS preamble start	t_{DDKHMP}	$-0.5 \times t_{MCK} - 0.6$	$-0.5 \times t_{MCK} + 0.6$	ns	6
MDQS epilogue end	t_{DDKHME}	-0.6	0.6	ns	6

Note:

1. The symbols used for timing specifications follow the pattern of $t_{(first\ two\ letters\ of\ functional\ block)(signal)(state)\ (reference)(state)}$ for inputs and $t_{(first\ two\ letters\ of\ functional\ block)(reference)(state)(signal)(state)}$ for outputs. Output hold time can be read as DDR timing (DD) from the rising or falling edge of the reference clock (KH or KL) until the output went invalid (AX or DX). For example, t_{DDKHAS} symbolizes DDR timing (DD) for the time t_{MCK} memory clock reference (K) goes from the high (H) state until outputs (A) are setup (S) or output valid time. Also, t_{DDKLDX} symbolizes DDR timing (DD) for the time t_{MCK} memory clock reference (K) goes low (L) until data outputs (D) are invalid (X) or data output hold time.
2. All MCK/MCK referenced measurements are made from the crossing of the two signals $\pm 0.1\ V$.
3. ADDR/CMD includes all DDR SDRAM output signals except MCK/MCK, MCS, and MDQ//MDM/MDQS.
4. Note that t_{DDKHMH} follows the symbol conventions described in note 1. For example, t_{DDKHMH} describes the DDR timing (DD) from the rising edge of the MCK[n] clock (KH) until the MDQS signal is valid (MH). t_{DDKHMH} can be modified through control of the DQSS override bits in the TIMING_CFG_2 register. This is typically set to the same delay as the clock adjust in the CLK_CNTL register. The timing parameters listed in the table assume that these 2 parameters have been set to the same adjustment value. See the *MPC8315E PowerQUICC II Pro Integrated Host Processor Family Reference Manual* for a description and understanding of the timing modifications enabled by use of these bits.
5. Determined by maximum possible skew between a data strobe (MDQS) and any corresponding bit of data (MDQ), ECC (), or data mask (MDM). The data strobe should be centered inside of the data eye at the pins of the microprocessor.
6. All outputs are referenced to the rising edge of MCK[n] at the pins of the microprocessor. Note that t_{DDKHMP} follows the symbol conventions described in note 1.

This figure shows the DDR SDRAM output timing for the MCK to MDQS skew measurement (t_{DDKHMH}).

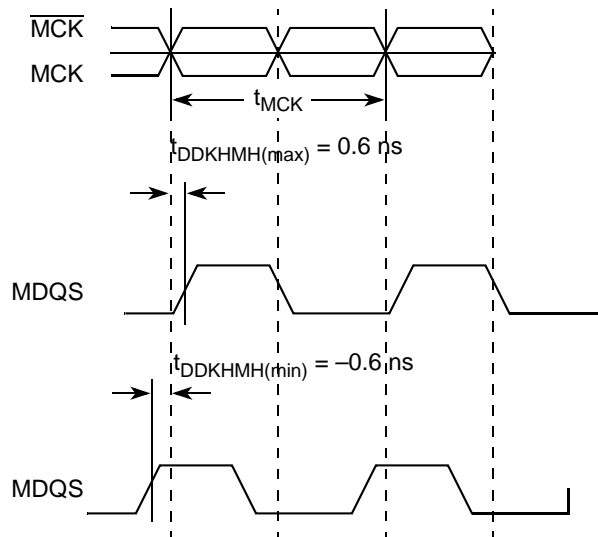

Figure 6. Timing Diagram for t_{DDKHMH}

This figure shows the DDR and DDR2 SDRAM output timing diagram.

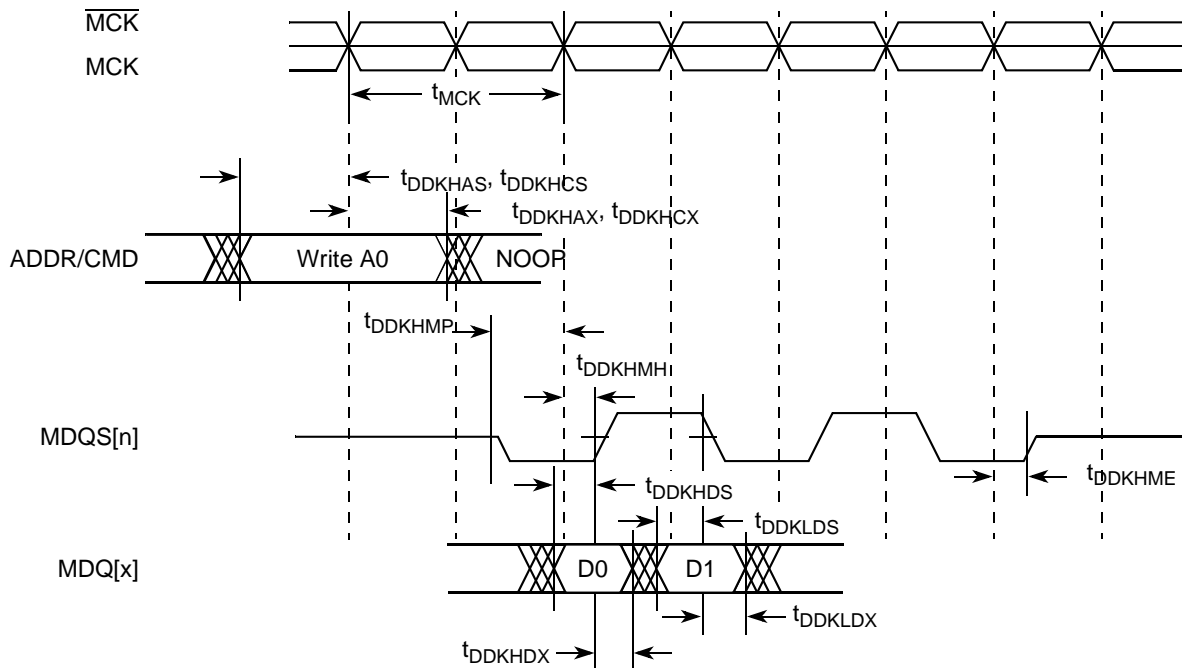

Figure 7. DDR and DDR2 SDRAM Output Timing Diagram

This figure provides the AC test load for the DDR bus.

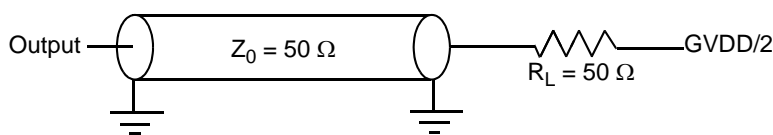

Figure 8. DDR AC Test Load

8 DUART

This section describes the DC and AC electrical specifications for the DUART interface.

8.1 DUART DC Electrical Characteristics

This table lists the DC electrical characteristics for the DUART interface.

Table 21. DUART DC Electrical Characteristics

Parameter	Symbol	Min	Max	Unit
High-level input voltage	V_{IH}	2.1	$NVDD + 0.3$	V
Low-level input voltage NVDD	V_{IL}	-0.3	0.8	V
High-level output voltage, $I_{OH} = -100 \mu A$	V_{OH}	$NVDD - 0.2$	—	V
Low-level output voltage, $I_{OL} = 100 \mu A$	V_{OL}	—	0.2	V
Input current ($0 V \leq V_{IN} \leq NVDD$)	I_{IN}	—	± 5	μA

8.2 DUART AC Electrical Specifications

This table lists the AC timing parameters for the DUART interface.

Table 22. DUART AC Timing Specifications

Parameter	Value	Unit	Note
Minimum baud rate	256	baud	—
Maximum baud rate	> 1,000,000	baud	1
Oversample rate	16	—	2

Note:

1. Actual attainable baud rate is limited by the latency of interrupt processing.
2. The middle of a start bit is detected as the eighth sampled 0 after the 1-to-0 transition of the start bit. Subsequent bit values are sampled each sixteenth sample.

9 Ethernet: Three-Speed Ethernet, MII Management

This section provides the AC and DC electrical characteristics for three-speed, 10/100/1000, and MII management.

9.1 eTSEC (10/100/1000 Mbps)—MII/RMII/RGMII/RTBI Electrical Characteristics

The electrical characteristics specified here apply to all the media-independent interface (MII), reduced gigabit MII (RGMII), and reduced ten-bit interface (RTBI) signals except management data input/output (MDIO) and management data clock (MDC). The MII and RMII is defined for 3.3 V, while the RGMII, and RTBI can operate at 2.5 V. The RGMII and RTBI follow the Hewlett-Packard reduced pin-count interface for Gigabit Ethernet Physical Layer Device Specification Version 1.2a (9/22/2000). The electrical characteristics for MDIO and MDC are specified in [Section 9.3, “Ethernet Management Interface Electrical Characteristics.”](#)

9.1.1 MII, RMII, RGMII, and RTBI DC Electrical Characteristics

All MII, RMII drivers and receivers comply with the DC parametric attributes specified in [Table 23](#) for 3.3-V operation and RGMII, RTBI drivers and receivers comply with the DC parametric attributes specified in [Table 24](#). The RGMII and RTBI signals are based on a 2.5 V CMOS interface voltage as defined by JEDEC EIA/JESD8–5.

NOTE

eTSEC should be interfaced with peripheral operating at same voltage level.

Table 23. MII/RMII (When Operating at 3.3 V) DC Electrical Characteristics

Parameter	Symbol	Conditions		Min	Max	Unit
Supply voltage 3.3 V	LVDD	—	—	3.0	3.6	V
Output high voltage	V_{OH}	$I_{OH} = -4.0 \text{ mA}$	LVDD = Min	2.40	LVDD + 0.3	V
Output low voltage	V_{OL}	$I_{OL} = 4.0 \text{ mA}$	LVDD = Min	V_{SS}	0.50	V
Input high voltage	V_{IH}	—	—	2.1	LVDD + 0.3	V
Input low voltage	V_{IL}	—	—	-0.3	0.90	V
Input high current	I_{IH}	$V_{IN}^1 = \text{LVDD}$		—	40	μA
Input low current	I_{IL}	$V_{IN}^1 = \text{VSS}$		-600	—	μA

Note:

1. The symbol V_{IN} , in this case, represents the LV_{IN} symbol referenced in [Table 1](#) and [Table 2](#).

Table 24. RGMII/RTBI (When Operating at 2.5 V) DC Electrical Characteristics

Parameters	Symbol	Conditions		Min	Max	Unit
Supply voltage 2.5 V	LVDD	—	—	2.37	2.63	V
Output high voltage	V_{OH}	$I_{OH} = -1.0 \text{ mA}$	LVDD = Min	2.00	LVDD + 0.3	V
Output low voltage	V_{OL}	$I_{OL} = 1.0 \text{ mA}$	LVDD = Min	$V_{SS} - 0.3$	0.40	V
Input high voltage	V_{IH}	—	LVDD = Min	1.7	LVDD + 0.3	V
Input low voltage	V_{IL}	—	LVDD = Min	-0.3	0.70	V
Input high current	I_{IH}	$V_{IN}^1 = \text{LVDD}$		—	15	μA
Input low current	I_{IL}	$V_{IN}^1 = \text{VSS}$		-15	—	μA

Table 24. RGMII/RTBI (When Operating at 2.5 V) DC Electrical Characteristics (continued)

Parameters	Symbol	Conditions	Min	Max	Unit
------------	--------	------------	-----	-----	------

Note:

1. The symbol V_{IN} , in this case, represents the LV_{IN} symbol referenced in Table 1 and Table 2.

9.2 MII, RMII, RGMII, and RTBI AC Timing Specifications

The AC timing specifications for MII, RMII, RGMII, and RTBI are presented in this section.

9.2.1 MII AC Timing Specifications

This section describes the MII transmit and receive AC timing specifications.

9.2.1.1 MII Transmit AC Timing Specifications

This table provides the MII transmit AC timing specifications.

Table 25. MII Transmit AC Timing Specifications

At recommended operating conditions with LVDD of 3.3 V ± 300 mv.

Parameter/Condition	Symbol ¹	Min	Typ	Max	Unit
TX_CLK clock period 10 Mbps	t_{MTX}	—	400	—	ns
TX_CLK clock period 100 Mbps	t_{MTX}	—	40	—	ns
TX_CLK duty cycle	t_{MTXH}/t_{MTX}	35	—	65	%
TX_CLK to MII data TXD[3:0], TX_ER, TX_EN delay	t_{MTKHDX}	1	5	15	ns
TX_CLK data clock rise $V_{IL}(\text{min})$ to $V_{IH}(\text{max})$	t_{MTXR}	1.0	—	4.0	ns
TX_CLK data clock fall $V_{IH}(\text{max})$ to $V_{IL}(\text{min})$	t_{MTXF}	1.0	—	4.0	ns

Note:

1. The symbols used for timing specifications follow the pattern of $t_{(\text{first two letters of functional block})(\text{signal})(\text{state})(\text{reference})(\text{state})}$ for inputs and $t_{(\text{first two letters of functional block})(\text{reference})(\text{state})(\text{signal})(\text{state})}$ for outputs. For example, t_{MTKHDX} symbolizes MII transmit timing (MT) for the time t_{MTX} clock reference (K) going high (H) until data outputs (D) are invalid (X). Note that, in general, the clock reference symbol representation is based on two to three letters representing the clock of a particular functional. For example, the subscript of t_{MTX} represents the MII(M) transmit (TX) clock. For rise and fall times, the latter convention is used with the appropriate letter: R (rise) or F (fall).

This figure shows the MII transmit AC timing diagram.

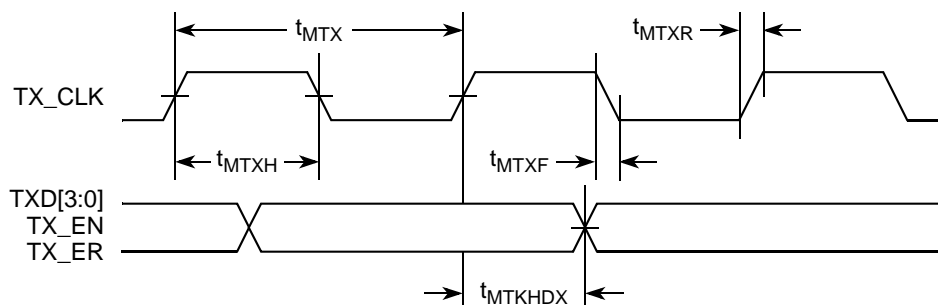

Figure 9. MII Transmit AC Timing Diagram

9.2.1.2 MII Receive AC Timing Specifications

This table provides the MII receive AC timing specifications.

Table 26. MII Receive AC Timing Specifications

At recommended operating conditions with LVDD of 3.3 V \pm 300 mv

Parameter/Condition	Symbol ¹	Min	Typ	Max	Unit
RX_CLK clock period 10 Mbps	t_{MRX}	—	400	—	ns
RX_CLK clock period 100 Mbps	t_{MRX}	—	40	—	ns
RX_CLK duty cycle	t_{MRXH}/t_{MRX}	35	—	65	%
RXD[3:0], RX_DV, RX_ER setup time to RX_CLK	t_{MRDVKH}	10.0	—	—	ns
RXD[3:0], RX_DV, RX_ER hold time to RX_CLK	t_{MRDXKH}	10.0	—	—	ns
RX_CLK clock rise $V_{IL}(\text{min})$ to $V_{IH}(\text{max})$	t_{MRXR}	1.0	—	4.0	ns
RX_CLK clock fall time $V_{IH}(\text{max})$ to $V_{IL}(\text{min})$	t_{MRXF}	1.0	—	4.0	ns

Note:

- The symbols used for timing specifications herein follow the pattern of $t_{(\text{first two letters of functional block})(\text{signal})(\text{state})(\text{reference})(\text{state})}$ for inputs and $t_{(\text{first two letters of functional block})(\text{reference})(\text{state})(\text{signal})(\text{state})}$ for outputs. For example, t_{MRDVKH} symbolizes MII receive timing (MR) with respect to the time data input signals (D) reach the valid state (V) relative to the t_{MRX} clock reference (K) going to the high (H) state or setup time. Also, t_{MRDXKL} symbolizes MII receive timing (GR) with respect to the time data input signals (D) went invalid (X) relative to the t_{MRX} clock reference (K) going to the low (L) state or hold time. Note that, in general, the clock reference symbol representation is based on three letters representing the clock of a particular functional. For example, the subscript of t_{MRX} represents the MII (M) receive (RX) clock. For rise and fall times, the latter convention is used with the appropriate letter: R (rise) or F (fall).
- The frequency of RX_CLK should not exceed the TX_CLK by more than 300 ppm

This figure provides the AC test load for eTSEC.

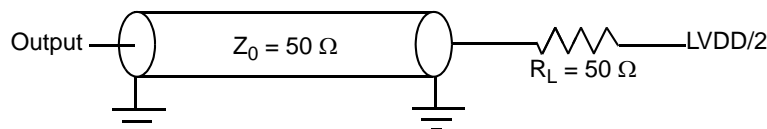

Figure 10. eTSEC AC Test Load

This figure shows the MII receive AC timing diagram.

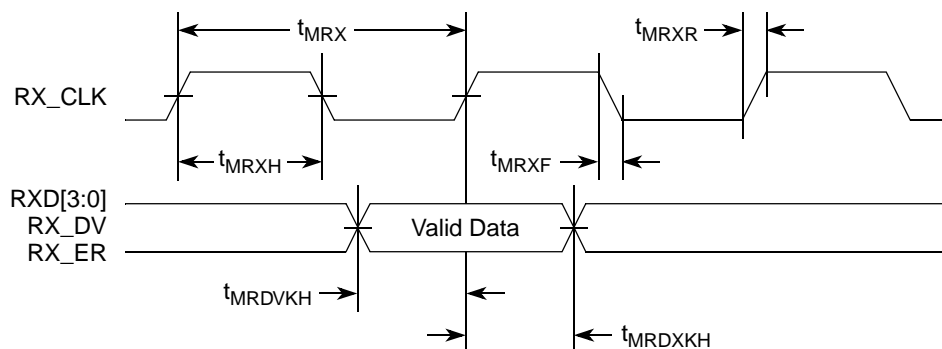

Figure 11. MII Receive AC Timing Diagram RMII AC Timing Specifications

9.2.2 RMII AC Timing Specifications

This section describes the RMII transmit and receive AC timing specifications.

9.2.2.1 RMII Transmit AC Timing Specifications

This section describes the RMII transmit and receive AC timing specifications. This table provides the RMII transmit AC timing specifications.

Table 27. RMII Transmit AC Timing Specifications

At recommended operating conditions with LVDD of 3.3 V ± 300 mv

Parameter/Condition	Symbol ¹	Min	Typ	Max	Unit
REF_CLK clock	t_{RMX}	—	20	—	ns
REF_CLK duty cycle	t_{RMXH}/t_{RMX}	35	—	65	%
REF_CLK to RMII data TXD[1:0], TX_EN delay	$t_{RMTKHDX}$	2	—	10	ns
REF_CLK data clock rise $V_{IL}(\text{min})$ to $V_{IH}(\text{max})$	t_{RMXR}	1.0	—	4.0	ns
REF_CLK data clock fall $V_{IH}(\text{max})$ to $V_{IL}(\text{min})$	t_{RMXF}	1.0	—	4.0	ns

Note:

- The symbols used for timing specifications herein follow the pattern of $t_{(\text{first three letters of functional block})(\text{signal})(\text{state})(\text{reference})(\text{state})}$ for inputs and $t_{(\text{first two letters of functional block})(\text{reference})(\text{state})(\text{signal})(\text{state})}$ for outputs. For example, $t_{RMTKHDX}$ symbolizes RMII transmit timing (RMT) for the time t_{RMX} clock reference (K) going high (H) until data outputs (D) are invalid (X). Note that, in general, the clock reference symbol representation is based on two to three letters representing the clock of a particular functional. For example, the subscript of t_{RMX} represents the RMII(RM) reference (X) clock. For rise and fall times, the latter convention is used with the appropriate letter: R (rise) or F (fall).

This figure shows the RMII transmit AC timing diagram.

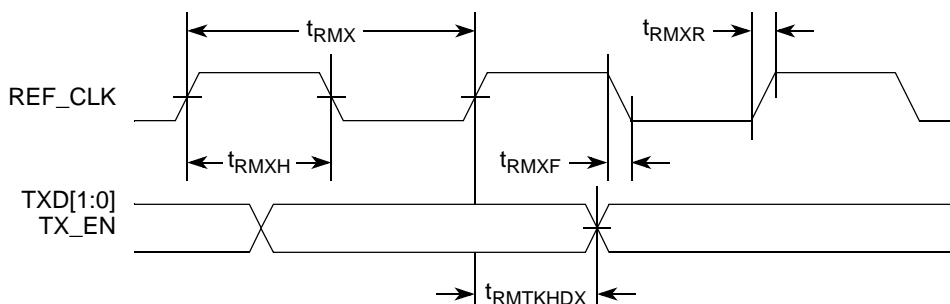

Figure 12. RMII Transmit AC Timing Diagram

9.2.2.2 RMII Receive AC Timing Specifications

This table provides the RMII receive AC timing specifications.

Table 28. RMII Receive AC Timing Specifications

At recommended operating conditions with LVDD of 3.3 V ± 300 mv

Parameter/Condition	Symbol ¹	Min	Typ	Max	Unit
REF_CLK clock period	t_{RMX}	—	20	—	ns
REF_CLK duty cycle	t_{RMXH}/t_{RMX}	35	—	65	%

Table 28. RMI Receive AC Timing Specifications (continued)

At recommended operating conditions with LVDD of 3.3 V ± 300 mv

Parameter/Condition	Symbol ¹	Min	Typ	Max	Unit
RXD[1:0], CRS_DV, RX_ER setup time to REF_CLK	t_{RMRDVKH}	4.0	—	—	ns
RXD[1:0], CRS_DV, RX_ER hold time to REF_CLK	t_{RMRDXKH}	2.0	—	—	ns
REF_CLK clock rise $V_{\text{IL}}(\text{min})$ to $V_{\text{IH}}(\text{max})$	t_{RMXR}	1.0	—	4.0	ns
REF_CLK clock fall time $V_{\text{IH}}(\text{max})$ to $V_{\text{IL}}(\text{min})$	t_{RMXF}	1.0	—	4.0	ns

Note:

- The symbols used for timing specifications herein follow the pattern of $t_{\text{(first three letters of functional block)(signal)(state)(reference)(state)}}$ for inputs and $t_{\text{(first two letters of functional block)(reference)(state)(signal)(state)}}$ for outputs. For example, t_{RMRDVKH} symbolizes RMI receive timing (RMR) with respect to the time data input signals (D) reach the valid state (V) relative to the t_{RMX} clock reference (K) going to the high (H) state or setup time. Also, t_{RMRDXKL} symbolizes RMI receive timing (RMR) with respect to the time data input signals (D) went invalid (X) relative to the t_{RMX} clock reference (K) going to the low (L) state or hold time. Note that, in general, the clock reference symbol representation is based on three letters representing the clock of a particular functional. For example, the subscript of t_{RMX} represents the RMI (RM) reference (X) clock. For rise and fall times, the latter convention is used with the appropriate letter: R (rise) or F (fall).

This figure provides the AC test load.

Figure 13. AC Test Load

This figure shows the RMI receive AC timing diagram.

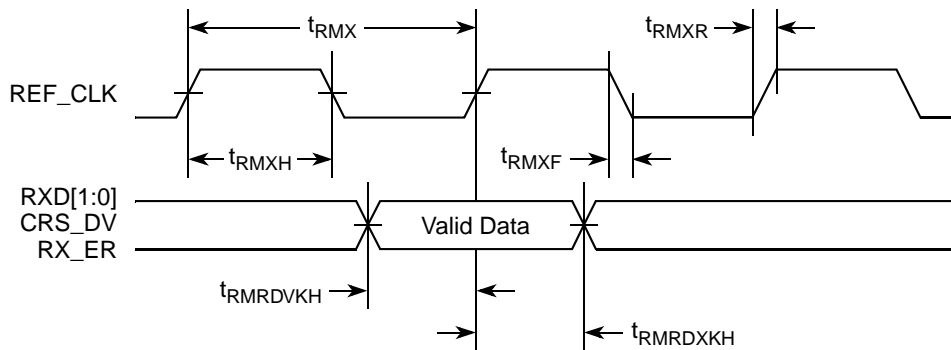
Figure 14. RMI Receive AC Timing Diagram

9.2.3 RGMII and RTBI AC Timing Specifications

This table presents the RGMII and RTBI AC timing specifications.

Table 29. RGMII and RTBI AC Timing Specifications

At recommended operating conditions (see Table 2)

Parameter/Condition	Symbol ¹	Min	Typ	Max	Unit
Data to clock output skew (at transmitter)	t_{SKRGT}	-0.6	—	0.6	ns
Data to clock input skew (at receiver) ²	t_{SKRGT}	1.0	—	2.6	ns

Table 29. RGMII and RTBI AC Timing Specifications (continued)

At recommended operating conditions (see Table 2)

Parameter/Condition	Symbol ¹	Min	Typ	Max	Unit
Clock cycle duration ³	t_{RGT}	7.2	8.0	8.8	ns
Duty cycle for 1000Base-T ^{4, 5}	t_{RGTH}/t_{RGT}	45	50	55	%
Duty cycle for 10BASE-T and 100BASE-TX ^{3, 5}	t_{RGTH}/t_{RGT}	40	50	60	%
Rise time (20%–80%)	t_{RGTR}	—	—	0.75	ns
Fall time (20%–80%)	t_{RGTF}	—	—	0.75	ns
GTX_CLK125 reference clock period	t_{G12}^6	—	8.0	—	ns
GTX_CLK125 reference clock duty cycle	t_{G125H}/t_{G125}	47	—	53	%

Note:

- Note that, in general, the clock reference symbol representation for this section is based on the symbols RGT to represent RGMII and RTBI timing. For example, the subscript of t_{RGT} represents the RTBI (T) receive (RX) clock. Note also that the notation for rise (R) and fall (F) times follows the clock symbol that is being represented. For symbols representing skews, the subscript is skew (SK) followed by the clock that is being skewed (RGT).
- This implies that PC board design requires clocks to be routed so that an additional trace delay of greater than 1.5 ns is added to the associated clock signal.
- For 10 and 100 Mbps, t_{RGT} scales to 400 ns \pm 40 ns and 40 ns \pm 4 ns, respectively.
- Duty cycle may be stretched/shrunk during speed changes or while transitioning to a received packet's clock domains as long as the minimum duty cycle is not violated and stretching occurs for no more than three t_{RGT} of the lowest speed transitioned between.
- Duty cycle reference is LVDD/2.
- This symbol is used to represent the external GTX_CLK125 and does not follow the original symbol naming convention. GTX_CLK supply voltage is fixed at 3.3V inside the chip. If PHY supplies a 2.5 V Clock signal on this input, set TSCOMOB1 bit of System I/O configuration register (SICRH) as 1. See the *MPC8315E PowerQUICC II Pro Integrated Host Processor Family Reference Manual*.
- The frequency of RX_CLK should not exceed the TX_CLK by more than 300 ppm

This figure shows the RGMII and RTBI AC timing and multiplexing diagrams.

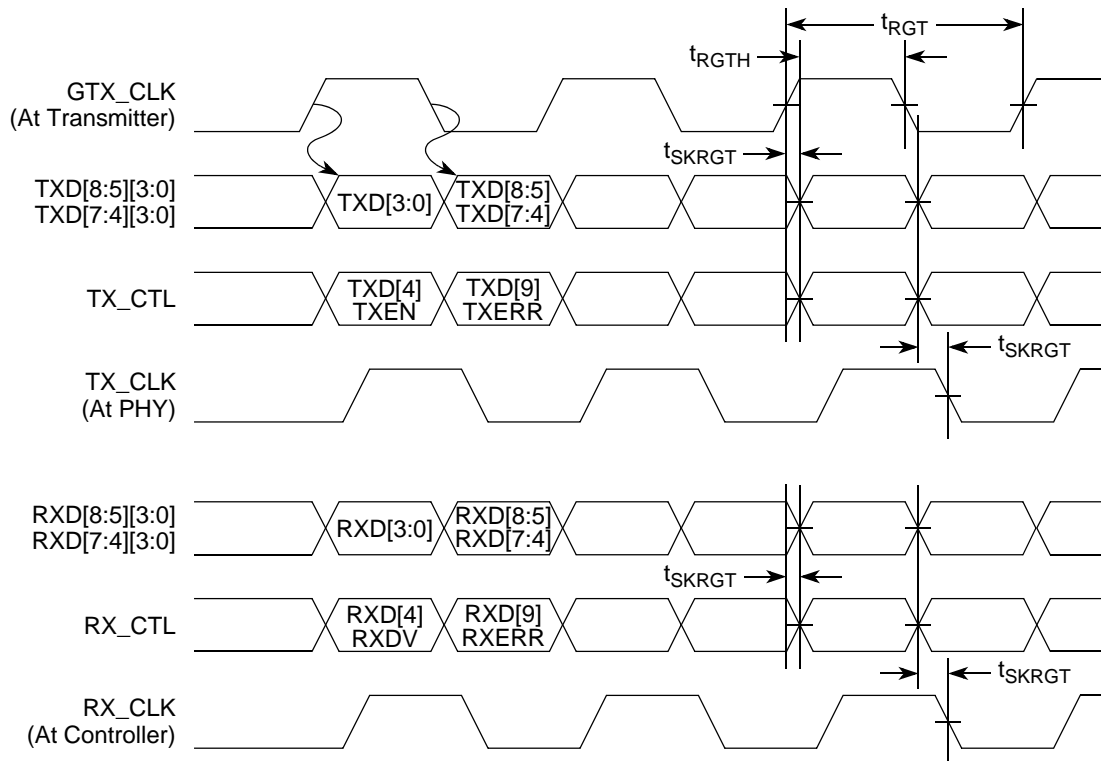

Figure 15. RGMII and RTBI AC Timing and Multiplexing Diagrams

9.3 Ethernet Management Interface Electrical Characteristics

The electrical characteristics specified here apply to MII management interface signals management data input/output (MDIO) and management data clock (MDC). The electrical characteristics for MII, RMII, RGMII, and RTBI are specified in [Section 9.1, “eTSEC \(10/100/1000 Mbps\)—MII/RMII/RGMII/RTBI Electrical Characteristics.”](#)

9.3.1 MII Management DC Electrical Characteristics

The MDC and MDIO are defined to operate at a supply voltage of 3.3 V. The DC electrical characteristics for MDIO and MDC are provided in this table.

Table 30. MII Management DC Electrical Characteristics Powered at 3.3 V

Parameter	Symbol	Conditions		Min	Max	Unit
Supply voltage (3.3 V)	NVDD	—	—	3.0	3.6	V
Output high voltage	V_{OH}	$I_{OH} = -1.0 \text{ mA}$	NVDD = Min	2.10	NVDD + 0.3	V
Output low voltage	V_{OL}	$I_{OL} = 1.0 \text{ mA}$	NVDD = Min	V_{SS}	0.50	V
Input high voltage	V_{IH}	—	—	2.00	—	V
Input low voltage	V_{IL}	—	—	—	0.80	V
Input high current	I_{IH}	NVDD = Max	$V_{IN}^1 = 2.1 \text{ V}$	—	40	μA

Table 30. MII Management DC Electrical Characteristics Powered at 3.3 V (continued)

Parameter	Symbol	Conditions		Min	Max	Unit
Input low current	I_{IL}	NVDD = Max	$V_{IN} = 0.5\text{ V}$	-600	—	μA

Note:

- The symbol V_{IN} , in this case, represents the NV_{IN} symbol referenced in [Table 1](#) and [Table 2](#).

9.3.2 MII Management AC Electrical Specifications

This table provides the MII management AC timing specifications.

Table 31. MII Management AC Timing Specifications

At recommended operating conditions with NVDD is 3.3 V \pm 300 mv

Parameter/Condition	Symbol ¹	Min	Typ	Max	Unit	Note
MDC frequency	f_{MDC}	—	2.5	—	MHz	2
MDC period	t_{MDC}	—	400	—	ns	—
MDC clock pulse width high	t_{MDCH}	32	—	—	ns	—
MDC to MDIO delay	t_{MDKHDX}	10	—	170	ns	3
MDIO to MDC setup time	t_{MDDVKH}	5	—	—	ns	—
MDIO to MDC hold time	t_{MDDXKH}	0	—	—	ns	—
MDC rise time	t_{MDCR}	—	—	10	ns	—
MDC fall time	t_{MDHF}	—	—	10	ns	—

Note:

- The symbols used for timing specifications herein follow the pattern of $t_{(\text{first two letters of functional block})(\text{signal})(\text{state})(\text{reference})(\text{state})}$ for inputs and $t_{(\text{first two letters of functional block})(\text{reference})(\text{state})(\text{signal})(\text{state})}$ for outputs. For example, t_{MDKHDX} symbolizes management data timing (MD) for the time t_{MDC} from clock reference (K) high (H) until data outputs (D) are invalid (X) or data hold time. Also, t_{MDDVKH} symbolizes management data timing (MD) with respect to the time data input signals (D) reach the valid state (V) relative to the t_{MDC} clock reference (K) going to the high (H) state or setup time. For rise and fall times, the latter convention is used with the appropriate letter: R (rise) or F (fall).
- This parameter is dependent on the `csb_clk` speed (that is, for a `csb_clk` of 133 MHz, the maximum frequency is 4.16 MHz and the minimum frequency is 0.593 MHz).
- This parameter is dependent on the `csb_clk` speed (that is, for a `csb_clk` of 133 MHz, the delay is 60 ns).

This figure shows the MII management AC timing diagram.

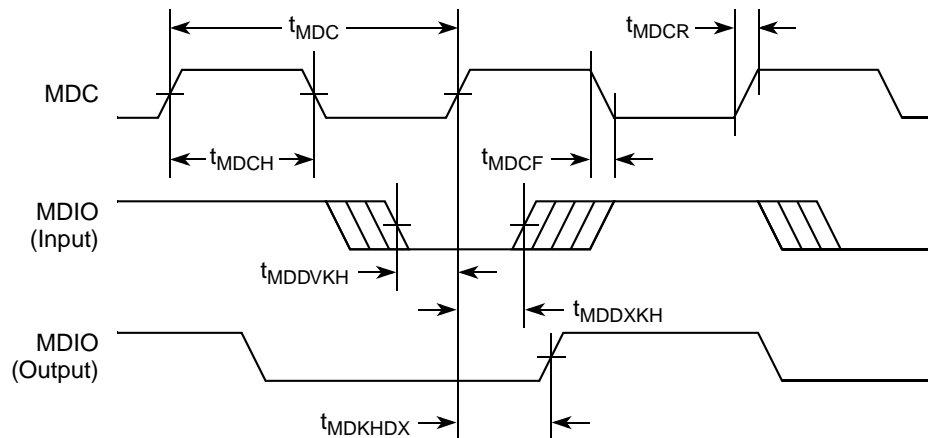

Figure 16. MII Management Interface Timing Diagram

9.4 1588 Timer Specifications

This section describes the DC and AC electrical specifications for the 1588 timer.

9.4.1 1588 Timer DC Specifications

This table provides the 1588 timer DC specifications.

Table 32. GPIO DC Electrical Characteristics

Characteristic	Symbol	Condition	Min	Max	Unit
Output high voltage	V_{OH}	$I_{OH} = -8.0 \text{ mA}$	2.4	—	V
Output low voltage	V_{OL}	$I_{OL} = 8.0 \text{ mA}$	—	0.5	V
Output low voltage	V_{OL}	$I_{OL} = 3.2 \text{ mA}$	—	0.4	V
Input high voltage	V_{IH}	—	2.0	$NVDD + 0.3$	V
Input low voltage	V_{IL}	—	-0.3	0.8	V
Input current	I_{IN}	$0 \text{ V} \leq V_{IN} \leq NVDD$	—	± 5	μA

9.4.2 1588 Timer AC Specifications

This table provides the 1588 timer AC specifications.

Table 33. 1588 Timer AC Specifications

Parameter	Symbol	Min	Max	Unit	Note
Timer clock cycle time	t_{TMRCK}	0	70	MHz	1
Input setup to timer clock	t_{TMRCKS}	—	—	—	2, 3
Input hold from timer clock	t_{TMRCKH}	—	—	—	2, 3
Output clock to output valid	t_{GCLKNV}	0	6	ns	
Timer alarm to output valid	t_{TMRAL}	—	—	—	2

Table 33. 1588 Timer AC Specifications (continued)

Parameter	Symbol	Min	Max	Unit	Note
-----------	--------	-----	-----	------	------

Note:

1. The timer can operate on rtc_clock or tmr_clock. These clocks get muxed and any one of them can be selected.
2. Asynchronous signals.
3. Inputs need to be stable at least one TMR clock.

9.5 SGMII Interface Electrical Characteristics

Each SGMII port features a 4-wire AC-Coupled serial link from the dedicated SerDes interface of MPC8315E as shown in [Figure 17](#), where C_{TX} is the external (on board) AC-Coupled capacitor. Each output pin of the SerDes transmitter differential pair features 50- Ω output impedance. Each input of the SerDes receiver differential pair features 50- Ω on-die termination to XCOREVSS. The reference circuit of the SerDes transmitter and receiver is shown in [Figure 48](#).

When an eTSEC port is configured to operate in SGMII mode, the parallel interface's output signals of this eTSEC port can be left floating. The input signals should be terminated based on the guidelines described in [Section 25.4, "Connection Recommendations,"](#) as long as such termination does not violate the desired POR configuration requirement on these pins, if applicable.

When operating in SGMII mode, the TSEC_GTX_CLK125 clock is not required for this port. Instead, SerDes reference clock is required on SD_REF_CLK and $\overline{SD_REF_CLK}$ pins.

9.5.1 DC Requirements for SGMII SD_REF_CLK and $\overline{SD_REF_CLK}$

The characteristics and DC requirements of the separate SerDes reference clock are described in [Section 15, "High-Speed Serial Interfaces \(HSSI\)."](#)

9.5.2 AC Requirements for SGMII SD_REF_CLK and $\overline{SD_REF_CLK}$

This table lists the SGMII SerDes reference clock AC requirements. Please note that SD_REF_CLK and $\overline{SD_REF_CLK}$ are not intended to be used with, and should not be clocked by, a spread spectrum clock source.

Table 34. SD_REF_CLK and $\overline{SD_REF_CLK}$ AC Requirements

Symbol	Parameter Description	Min	Typical	Max	Unit	Note
t_{REF}	REFCLK cycle time	—	8	—	ns	—
t_{REFCJ}	REFCLK cycle-to-cycle jitter. Difference in the period of any two adjacent REFCLK cycles	—	—	100	ps	—
t_{REFPJ}	Phase jitter. Deviation in edge location with respect to mean edge location	-50	—	50	ps	—

9.5.3 SGMII Transmitter and Receiver DC Electrical Characteristics

[Table 35](#) and [Table 36](#) describe the SGMII SerDes transmitter and receiver AC-coupled DC electrical characteristics. Transmitter DC characteristics are measured at the transmitter outputs (SD_TX[n] and $\overline{SD_TX[n]}$) as depicted in [Figure 16](#).

Table 35. SGMII DC Transmitter Electrical Characteristics

Parameter	Symbol	Min	Typ	Max	Unit	Note
Supply Voltage	XCOREVDD	0.95	1.0	1.05	V	—
Output high voltage	VOH	—	—	$XCOREVDD_{Typ}/2 + V_{OD} _{max}/2$	mV	1
Output low voltage	VOL	$XCOREVDD_{Typ}/2 - V_{OD} _{max}/2$	—	—	mV	1
Output ringing	V _{RING}	—	—	10	%	—
Output differential voltage ^{2, 3, 5}	V _{OD}	323	500	725	mV	Equalization setting: 1.0x
		296	459	665		Equalization setting: 1.09x
		269	417	604		Equalization setting: 1.2x
		243	376	545		Equalization setting: 1.33x
		215	333	483		Equalization setting: 1.5x
		189	292	424		Equalization setting: 1.71x
		162	250	362		Equalization setting: 2.0x
Output offset voltage	V _{OS}	425	500	575	mV	1, 4
Output impedance (single-ended)	R _O	40	—	60	Ω	—
Mismatch in a pair	ΔR _O	—	—	10	%	—
Change in V _{OD} between “0” and “1”	Δ V _{OD}	—	—	25	mV	—
Change in V _{OS} between “0” and “1”	ΔV _{OS}	—	—	25	mV	—
Output current on short to GND	I _{SA} , I _{SB}	—	—	40	mA	—

Note:

- This will not align to DC-coupled SGMII. XCOREVDD_{Typ}=1.0V.
- $|V_{OD}| = |V_{TXn} - V_{\overline{TXn}}|$. |V_{OD}| is also referred as output differential peak voltage. $V_{TX-DIFFp-p} = 2*|V_{OD}|$.
- The |V_{OD}| value shown in the table assumes the following transmit equalization setting in the TXEQA (for SerDes lane A) or TXEQE (for SerDes lane E) bit field of MPC8315E's SerDes Control Register 0:
 - The LSBs (bit [1:3]) of the above bit field is set based on the equalization setting shown in table.
- V_{OS} is also referred to as output common mode voltage.
- The |V_{OD}| value shown in the Typ column is based on the condition of XCOREVDD_{Typ}=1.0V, no common mode offset variation (V_{OS} = 500 mV), SerDes transmitter is terminated with 100-Ω differential load between TX[n] and $\overline{TX}[n]$.

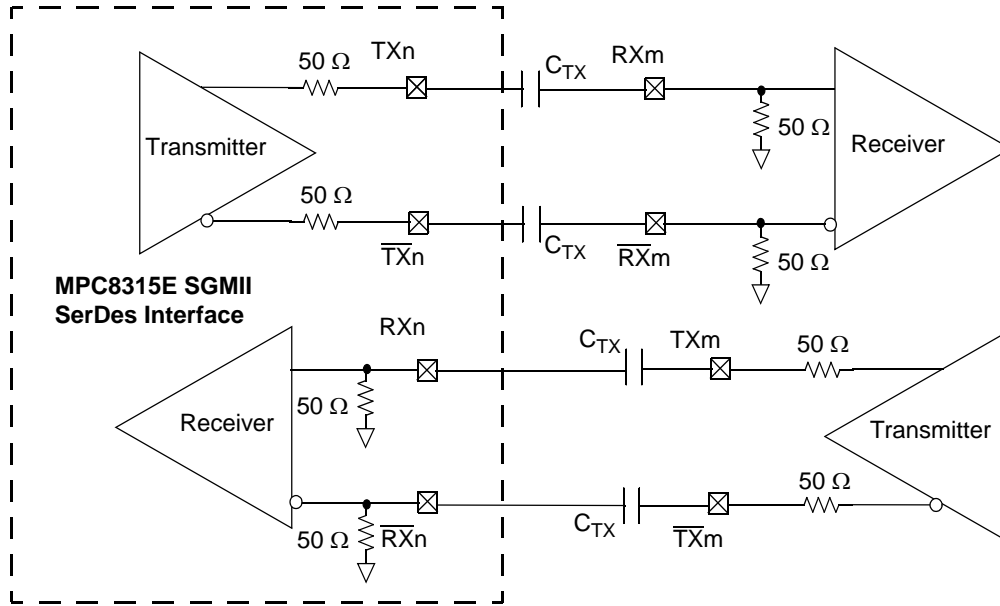

Figure 17. 4-Wire AC-Coupled SGMII Serial Link Connection Example

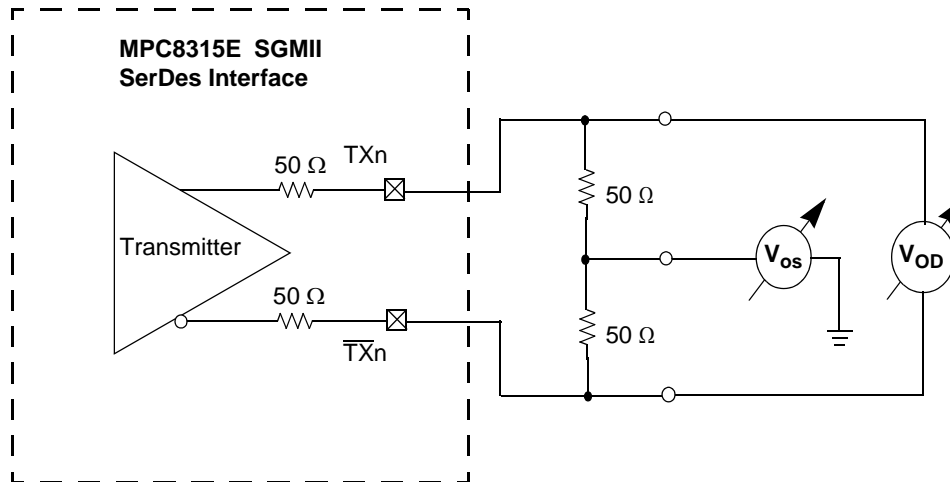

Figure 18. SGMII Transmitter DC Measurement Circuit

Table 36. SGMII DC Receiver Electrical Characteristics

Parameter	Symbol	Min	Typ	Max	Unit	Note	
Supply Voltage	XCOREVDD	0.95	1.0	1.05	V	—	
DC Input voltage range	—	N/A			—	1	
Input differential voltage	EQ = 0	$V_{RX_DIFFp-p}$	100	—	1200	mV	2, 4
	EQ = 1		175	—			
Loss of signal threshold	EQ = 0	VLOS	30	—	100	mV	3, 4
	EQ = 1		65	—	175		

Table 36. SGMII DC Receiver Electrical Characteristics (continued)

Parameter	Symbol	Min	Typ	Max	Unit	Note
Input AC common mode voltage	V_{CM_ACp-p}	—	—	100	mV	5
Receiver differential input impedance	Z_{RX_DIFF}	80	100	120	Ω	—
Receiver common mode input impedance	Z_{RX_CM}	20	—	35	Ω	—
Common mode input voltage	V_{CM}	—	$V_{xcorevss}$	—	V	6

Note:

1. Input must be externally AC-coupled.
2. $V_{RX_DIFFp-p}$ is also referred to as peak to peak input differential voltage
3. The concept of this parameter is equivalent to the Electrical Idle Detect Threshold parameter in PCI Express. Refer to PCI Express Differential Receiver (RX) Input Specifications section for further explanation.
4. The EQ shown in the table refers to the RXEQA or RXEQE bit field of MPC8315E's SerDes Control Register 0.
5. V_{CM_ACp-p} is also referred to as peak to peak AC common mode voltage.
6. On-chip termination to XCOREVSS.

9.5.4 SGMII AC Timing Specifications

This section describes the SGMII transmit and receive AC timing specifications. Transmitter and receiver characteristics are measured at the transmitter outputs (TX[n] and $\overline{TX}[n]$) or at the receiver inputs (RX[n] and $\overline{RX}[n]$) as depicted in [Figure 20](#) respectively.

9.5.4.1 SGMII Transmit AC Timing Specifications

This table provides the SGMII transmit AC timing targets. A source synchronous clock is not provided.

Table 37. SGMII Transmit AC Timing Specifications

At recommended operating conditions with XCOREVDD = 1.0V \pm 5%.

Parameter	Symbol	Min	Typ	Max	Unit	Note
Deterministic Jitter	JD	—	—	0.17	UI p-p	—
Total Jitter	JT	—	—	0.35	UI p-p	—
Unit Interval	UI	799.92	800	800.08	ps	—
V_{OD} fall time (80%-20%)	t_{fall}	50	—	120	ps	—
V_{OD} rise time (20%-80%)	t_{rise}	50	—	120	ps	—

Note:

1. Each UI is 800 ps \pm 100 ppm.

9.5.4.2 SGMII Receive AC Timing Specifications

This table provides the SGMII receive AC timing specifications. Source synchronous clocking is not supported. Clock is recovered from the data. [Figure 19](#) shows the SGMII Receiver Input Compliance Mask eye diagram.

Table 38. SGMII Receive AC Timing Specifications

At recommended operating conditions with XCOREVDD = 1.0V ± 5%.

Parameter	Symbol	Min	Typ	Max	Unit	Note
Deterministic Jitter Tolerance	JD	0.37	—	—	UI p-p	1
Combined Deterministic and Random Jitter Tolerance	JDR	0.55	—	—	UI p-p	1
Sinusoidal Jitter Tolerance	JSIN	0.1	—	—	UI p-p	1
Total Jitter Tolerance	JT	0.65	—	—	UI p-p	1
Bit Error Ratio	BER	—	—	10^{-12}		—
Unit Interval	UI	799.92	800	800.08	ps	2
AC Coupling Capacitor	C _{TX}	5	—	200	nF	3

Note:

1. Measured at receiver.
2. Each UI is 800 ps ± 100 ppm.
3. The external AC coupling capacitor is required. It's recommended to be placed near the device transmitter outputs.
4. Refer to RapidIO™ 1x/4x LP Serial Physical Layer Specification for interpretation of jitter specifications.

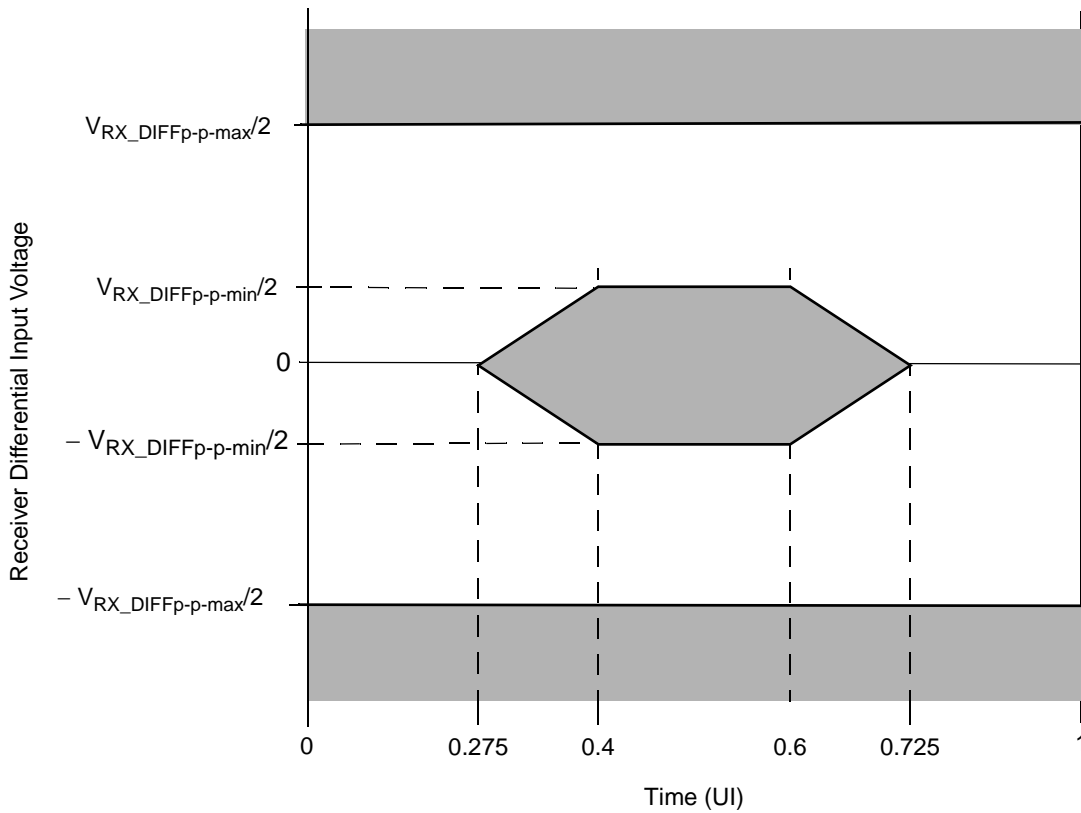

Figure 19. SGMII Receiver Input Compliance Mask

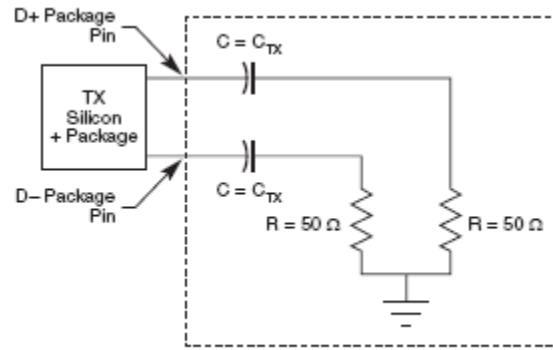

Figure 20. SGMII AC Test/Measurement Load

10 USB

10.1 USB Dual-Role Controllers

This section provides the AC and DC electrical specifications for the USB-ULPI interface.

10.1.1 USB DC Electrical Characteristics

This table lists the DC electrical characteristics for the USB interface.

Table 39. USB DC Electrical Characteristics

Parameter	Symbol	Min	Max	Unit
High-level input voltage	V_{IH}	2	LVDD + 0.3	V
Low-level input voltage	V_{IL}	-0.3	0.8	V
Input current	I_{IN}	—	±5	μA
High-level output voltage, $I_{OH} = -100 \mu A$	V_{OH}	LVDD - 0.2	—	V
Low-level output voltage, $I_{OL} = 100 \mu A$	V_{OL}	—	0.2	V

Note:

1. The symbol V_{IN} , in this case, represents the NV_{IN} symbol referenced in [Table 1](#) and [Table 2](#).

10.1.2 USB AC Electrical Specifications

This table lists the general timing parameters of the USB-ULPI interface.

Table 40. USB General Timing Parameters

Parameter	Symbol ¹	Min	Max	Unit	Note
USB clock cycle time	t_{USCK}	15	—	ns	1, 2
Input setup to USB clock—all inputs	t_{USIVKH}	4	—	ns	1, 4
Input hold to USB clock—all inputs	t_{USIXKH}	1	—	ns	1, 4

Table 40. USB General Timing Parameters (continued)

Parameter	Symbol ¹	Min	Max	Unit	Note
USB clock to output valid—all outputs	t_{USKHOV}	—	9	ns	1
Output hold from USB clock—all outputs	t_{USKHOX}	1	—	ns	1

Note:

1. The symbols used for timing specifications follow the pattern of $t_{(First\ two\ letters\ of\ functional\ block)(signal)(state)(reference)(state)}$ for inputs and $t_{(First\ two\ letters\ of\ functional\ block)(reference)(state)(signal)(state)}$ for outputs. For example, t_{USIXKH} symbolizes USB timing (US) for the input (I) to go invalid (X) with respect to the time the USB clock reference (K) goes high (H). Also, t_{USKHOX} symbolizes USB timing (US) for the us clock reference (K) to go high (H), with respect to the output (O) going invalid (X) or output hold time.
2. All timings are in reference to USB clock.
3. All signals are measured from NVDD/2 of the rising edge of USB clock to $0.4 \times NVDD$ of the signal in question for 3.3-V signaling levels.
4. Input timings are measured at the pin.
5. For purposes of active/float timing measurements, the Hi-Z or off-state is defined to be when the total current delivered through the component pin is less than or equal to the leakage current specification.

Figure 21 and Figure 22 provide the AC test load and signals for the USB, respectively.

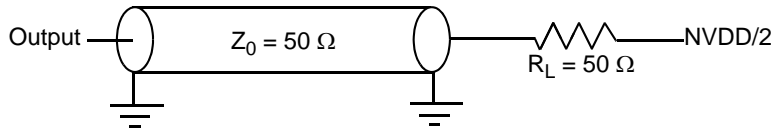

Figure 21. USB AC Test Load

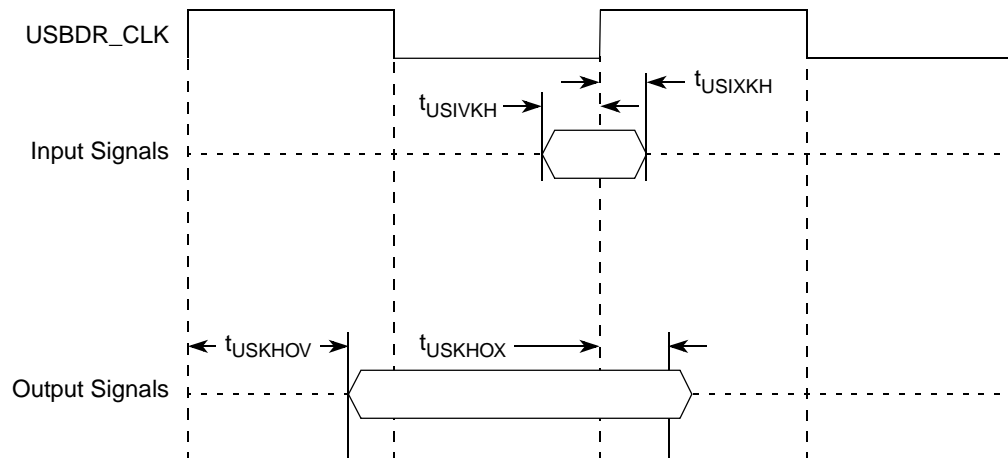

Figure 22. USB Signals

10.2 On-Chip USB PHY

This section provides the AC and DC electrical specifications for the USB PHY interface of the MPC8314E.

For details refer to Tables 7-7 through 7-10, and Table 7-14 in the *USB 2.0 Specifications document*, and the pull-up/down resistors ECN updates, all available at www.usb.org.

This table provides the USB clock input (USB_CLK_IN) DC timing specifications.

Table 41. USB_CLK_IN DC Electrical Characteristics

Parameter	Symbol	Min	Max	Unit
Input high voltage	V_{IH}	2.7	$NV_{DD} + 0.3$	V
Input low voltage	V_{IL}	-0.3	0.4	V

This table provides the USB clock input (USB_CLK_IN) AC timing specifications.

Table 42. USB_CLK_IN AC Timing Specifications

Parameter/Condition	Conditions	Symbol	Min	Typical	Max	Unit
Frequency range	—	$f_{USB_CLK_IN}$	—	24	—	MHz
Clock frequency tolerance	—	t_{CLK_TOL}	-0.005	0	0.005	%
Reference clock duty cycle	Measured at 1.6 V	t_{CLK_DUTY}	40	50	60	%
Total input jitter/Time interval error	Peak to peak value measured with a second order high-pass filter of 500 KHz bandwidth	t_{CLK_PJ}	—	—	200	ps

11 Local Bus

This section describes the DC and AC electrical specifications for the local bus interface of the MPC8314E.

11.1 Local Bus DC Electrical Characteristics

This table provides the DC electrical characteristics for the local bus interface.

Table 43. DC Electrical Characteristics (when Operating at 3.3 V)

Parameter	Symbol	Min	Max	Unit
Output high voltage ($NV_{DD} = \text{min}$, $I_{OH} = -2 \text{ mA}$)	V_{OH}	$NV_{DD} - 0.2$	—	V
Output low voltage ($NV_{DD} = \text{min}$, $I_{OL} = 2 \text{ mA}$)	V_{OL}	—	0.2	V
Input high voltage	V_{IH}	2	$NV_{DD} + 0.3$	V
Input low voltage	V_{IL}	-0.3	0.8	V
Input high current ($V_{IN} = 0 \text{ V}$ or $V_{IN} = NV_{DD}$)	I_{IN}	—	± 5	μA

11.2 Local Bus AC Electrical Specifications

This table describes the general timing parameters of the local bus interface of the MPC8314E.

Table 44. Local Bus General Timing Parameters

Parameter	Symbol ¹	Min	Max	Unit	Note
Local bus cycle time	t_{LBK}	15	—	ns	2
Input setup to local bus clock	t_{LBIVKH}	7	—	ns	3, 4

Table 44. Local Bus General Timing Parameters (continued)

Parameter	Symbol ¹	Min	Max	Unit	Note
Input hold from local bus clock	t_{LBIXKH}	1.0	—	ns	3, 4
LALE output fall to LAD output transition (LATCH hold time)	$t_{LBOTOT1}$	1.5	—	ns	5
LALE output fall to LAD output transition (LATCH hold time)	$t_{LBOTOT2}$	3	—	ns	6
LALE output fall to LAD output transition (LATCH hold time)	$t_{LBOTOT3}$	2.5	—	ns	7
Local bus clock to output valid	t_{LBKHOV}	—	3	ns	3
Local bus clock to output high impedance for LAD	t_{LBKHOZ}	—	4	ns	8
LALE output rise to LCLK negative edge	$t_{LALEHOV}$	—	3.0	ns	

Note:

1. The symbols used for timing specifications herein follow the pattern of $t_{(\text{First two letters of functional block})(\text{signal})(\text{state})(\text{reference})(\text{state})}$ for inputs and $t_{(\text{First two letters of functional block})(\text{reference})(\text{state})(\text{signal})(\text{state})}$ for outputs. For example, $t_{LBIXKH1}$ symbolizes local bus timing (LB) for the input (I) to go invalid (X) with respect to the time the t_{LBK} clock reference (K) goes high (H), in this case for clock one(1). Also, t_{LBKHOX} symbolizes local bus timing (LB) for the t_{LBK} clock reference (K) to go high (H), with respect to the output (O) going invalid (X) or output hold time.
2. All timings are in reference to falling edge of LCLK0 (for all outputs and for \overline{LGTA} and LUPWAIT inputs) or rising edge of LCLK0 (for all other inputs).
3. All signals are measured from $NVDD/2$ of the rising/falling edge of LCLK0 to $0.4 \times NVDD$ of the signal in question for 3.3-V signaling levels.
4. Input timings are measured at the pin.
5. $t_{LBOTOT1}$ should be used when RCWH[LALE] is not set and the load on LALE output pin is at least 10pF less than the load on LAD output pins.
6. $t_{LBOTOT2}$ should be used when RCWH[LALE] is set and the load on LALE output pin is at least 10pF less than the load on LAD output pins.
7. $t_{LBOTOT3}$ should be used when RCWH[LALE] is set and the load on LALE output pin equals to the load on LAD output pins.
8. For active/float timing measurements, the Hi-Z or off state is defined to be when the total current delivered through the component pin is less than or equal to the leakage current specification.

This figure provides the AC test load for the local bus.

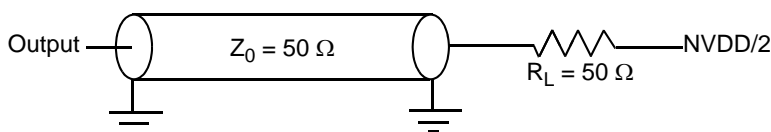

Figure 23. Local Bus AC Test Load

Figure 24 through Figure 26 show the local bus signals.

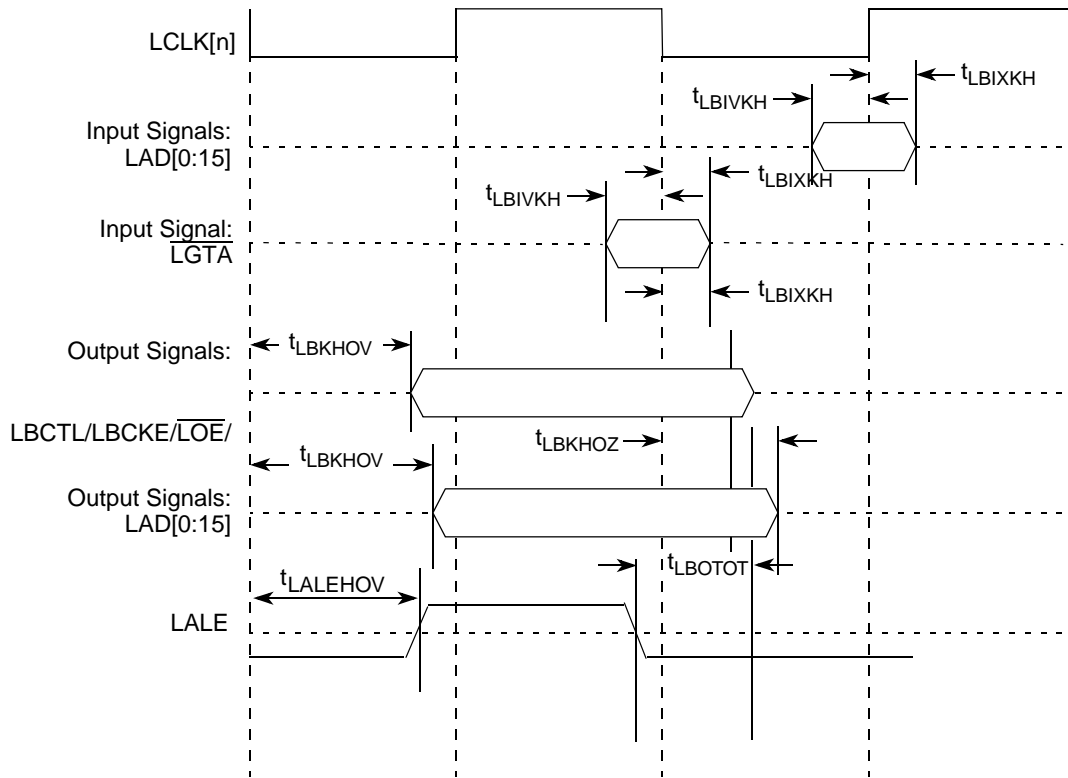

Figure 24. Local Bus Signals, Nonspecial Signals Only

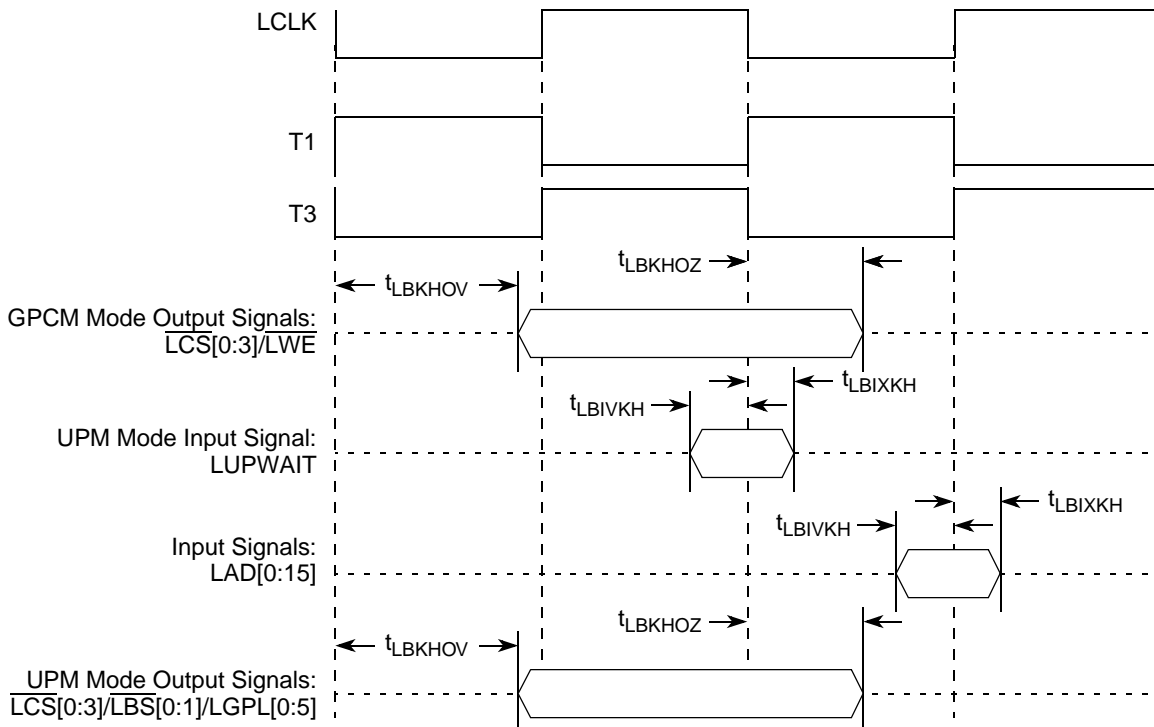

Figure 25. Local Bus Signals, GPCM/UPM Signals for LCRR[CLKDIV] = 2

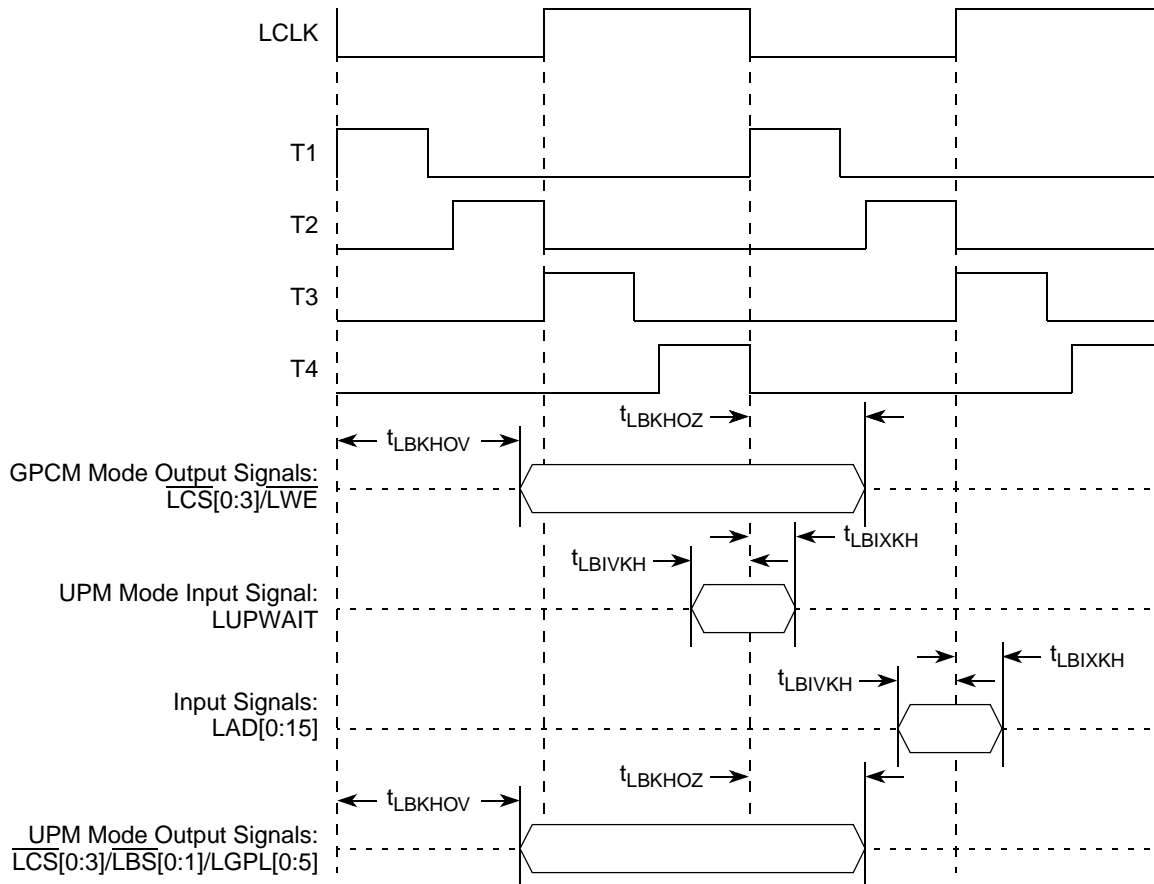

Figure 26. Local Bus Signals, GPCM/UPM Signals for LCRR[CLKDIV] = 4

12 JTAG

This section describes the DC and AC electrical specifications for the IEEE Std 1149.1™ (JTAG) interface.

12.1 JTAG DC Electrical Characteristics

This table provides the DC electrical characteristics for the IEEE 1149.1 (JTAG) interface.

Table 45. JTAG Interface DC Electrical Characteristics

Characteristic	Symbol	Condition	Min	Max	Unit
Input high voltage	V_{IH}	—	2.1	$NVDD + 0.3$	V
Input low voltage	V_{IL}	—	-0.3	0.8	V
Input current	I_{IN}	—	—	±5	μA
Output high voltage	V_{OH}	$I_{OH} = -8.0$ mA	2.4	—	V
Output low voltage	V_{OL}	$I_{OL} = 8.0$ mA	—	0.5	V
Output low voltage	V_{OL}	$I_{OL} = 3.2$ mA	—	0.4	V

12.2 JTAG AC Timing Specifications

This section describes the AC electrical specifications for the IEEE 1149.1 (JTAG) interface. This table provides the JTAG AC timing specifications as defined in [Figure 28](#) through [Figure 31](#).

Table 46. JTAG AC Timing Specifications (Independent of SYS_CLK_IN) ¹

At recommended operating conditions (see [Table 2](#))

Parameter	Symbol ²	Min	Max	Unit	Note
JTAG external clock frequency of operation	f_{JTG}	0	33.3	MHz	—
JTAG external clock cycle time	t_{JTG}	30	—	ns	—
JTAG external clock pulse width measured at 1.4 V	t_{JTKHKL}	15	—	ns	—
JTAG external clock rise and fall times	t_{JTGR}, t_{JTGF}	0	2	ns	—
\overline{TRST} assert time	t_{TRST}	25	—	ns	3
Input setup times:				ns	4
Boundary-scan data TMS, TDI	t_{JTDVKH} t_{JTIVKH}	4 4	— —		
Input hold times:				ns	4
Boundary-scan data TMS, TDI	t_{JTDXKH} t_{JTIXKH}	10 10	— —		
Valid times:				ns	5
Boundary-scan data TDO	t_{JTKLDV} t_{JTKLOV}	2 2	11 11		
Output hold times:				ns	5
Boundary-scan data TDO	t_{JTKLDX} t_{JTKLOX}	2 2	— —		
JTAG external clock to output high impedance:				ns	5, 6
Boundary-scan data TDO	t_{JTKLDZ} t_{JTKLOZ}	2 2	19 9		

Note:

- All outputs are measured from the midpoint voltage of the falling/rising edge of t_{TCLK} to the midpoint of the signal in question. The output timings are measured at the pins. All output timings assume a purely resistive 50-Ω load (see [Table 27](#)). Time-of-flight delays must be added for trace lengths, vias, and connectors in the system.
- The symbols used for timing specifications herein follow the pattern of $t_{(first\ two\ letters\ of\ functional\ block)(reference)(state)(signal)(state)}$ for inputs and $t_{(first\ two\ letters\ of\ functional\ block)(reference)(state)(signal)(state)}$ for outputs. For example, t_{JTDVKH} symbolizes JTAG device timing (JT) with respect to the time data input signals (D) reaching the valid state (V) relative to the t_{JTG} clock reference (K) going to the high (H) state or setup time. Also, t_{JTDXKH} symbolizes JTAG timing (JT) with respect to the time data input signals (D) went invalid (X) relative to the t_{JTG} clock reference (K) going to the high (H) state. Note that, in general, the clock reference symbol representation is based on three letters representing the clock of a particular functional. For rise and fall times, the latter convention is used with the appropriate letter: R (rise) or F (fall).
- \overline{TRST} is an asynchronous level sensitive signal. The setup time is for test purposes only.
- Non-JTAG signal input timing with respect to t_{TCLK} .
- Non-JTAG signal output timing with respect to t_{TCLK} .
- Guaranteed by design and characterization.

This figure provides the AC test load for TDO and the boundary-scan outputs of the MPC8314E.

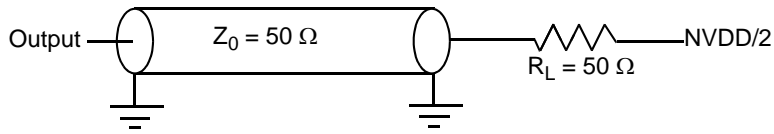

Figure 27. AC Test Load for the JTAG Interface

This figure provides the JTAG clock input timing diagram.

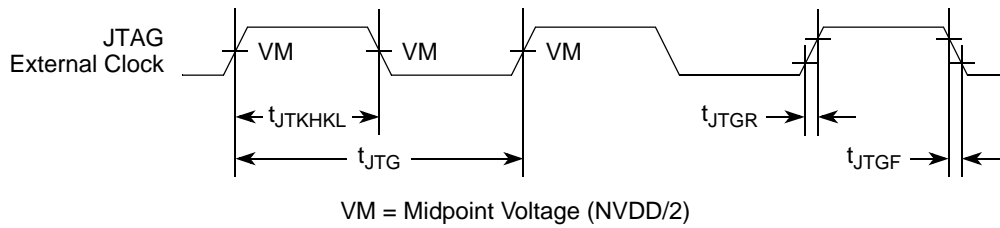

Figure 28. JTAG Clock Input Timing Diagram

This figure provides the $\overline{\text{TRST}}$ timing diagram.

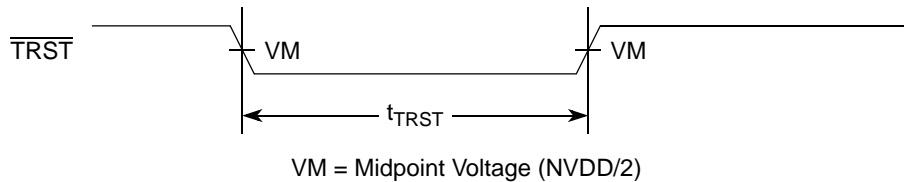

Figure 29. $\overline{\text{TRST}}$ Timing Diagram

This figure provides the boundary-scan timing diagram.

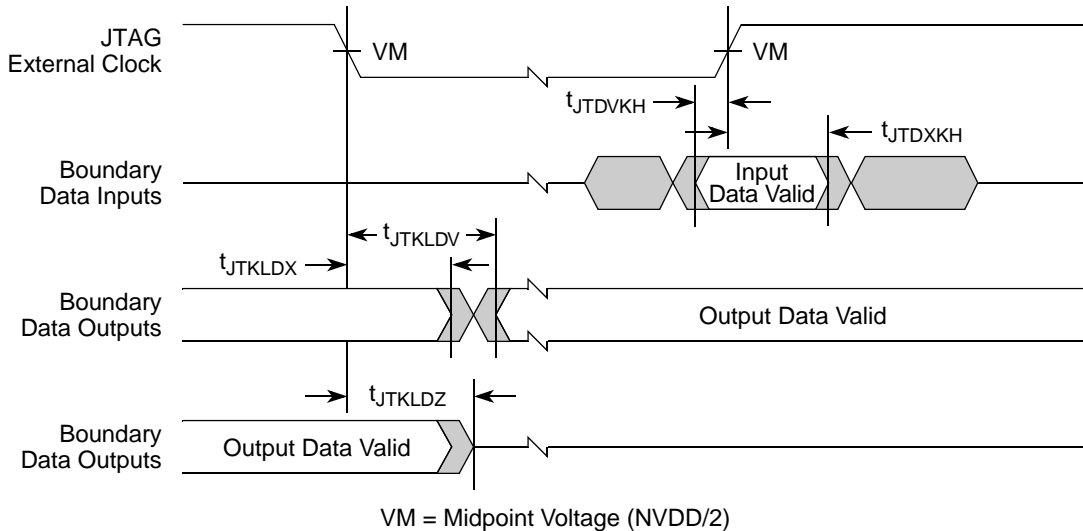

Figure 30. Boundary-Scan Timing Diagram

This figure provides the test access port timing diagram.

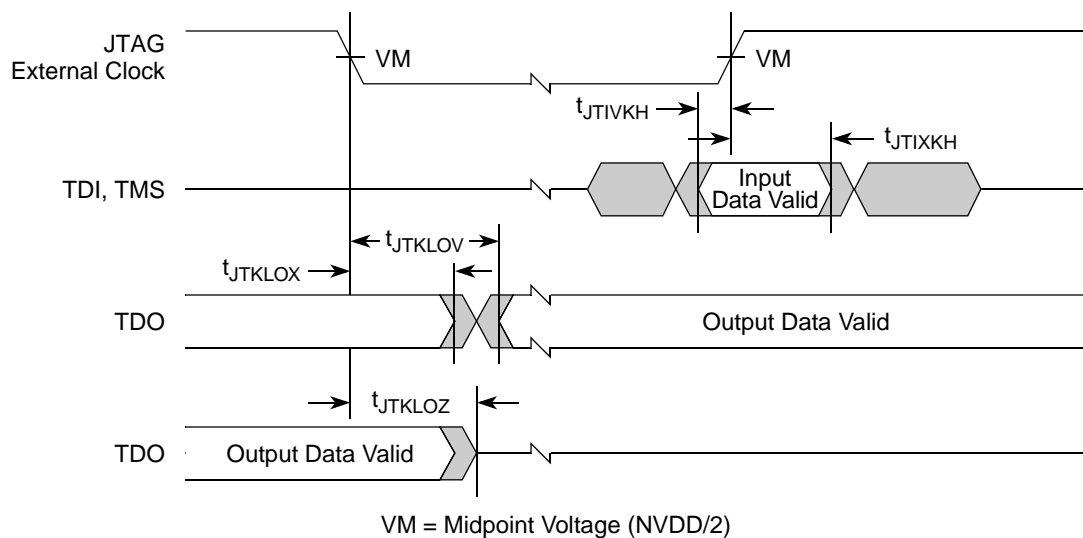

Figure 31. Test Access Port Timing Diagram

13 I²C

This section describes the DC and AC electrical characteristics for the I²C interface of the MPC8314E.

13.1 I²C DC Electrical Characteristics

This table provides the DC electrical characteristics for the I²C interface.

Table 47. I²C DC Electrical Characteristics

At recommended operating conditions with NVDD of 3.3 V ± 300 mV

Parameter	Symbol	Min	Max	Unit	Note
Input high voltage level	V _{IH}	0.7 × NVDD	NVDD + 0.3	V	—
Input low voltage level	V _{IL}	-0.3	0.3 × NVDD	V	—
Low level output voltage	V _{OL}	0	0.2 × NVDD	V	1
High level output voltage	V _{OH}	0.8 × NVDD	NVDD + 0.3	V	—
Output fall time from V _{IH} (min) to V _{IL} (max) with a bus capacitance from 10 to 400 pF	t _{I2KLV}	20 + 0.1 × C _B	250	ns	2
Pulse width of spikes which must be suppressed by the input filter	t _{I2KHL}	0	50	ns	3
Capacitance for each I/O pin	C _I	—	10	pF	—
Input current (0 V ≤ V _{IN} ≤ NVDD)	I _{IN}	—	± 5	μA	4

Note:

- Output voltage (open drain or open collector) condition = 3 mA sink current.
- C_B = capacitance of one bus line in pF.
- See the *MPC8315E PowerQUICC II Pro Integrated Host Processor Family Reference Manual* for information on the digital filter used.
- I/O pins obstruct the SDA and SCL lines if NVDD is switched off.

13.2 I²C AC Electrical Specifications

This table provides the AC timing parameters for the I²C interface.

Table 48. I²C AC Electrical Specifications

All values refer to V_{IH} (min) and V_{IL} (max) levels (see Table 47)

Parameter	Symbol ¹	Min	Max	Unit
SCL clock frequency	f _{I2C}	0	400	kHz
Low period of the SCL clock	t _{I2CL}	1.3	—	μs
High period of the SCL clock	t _{I2CH}	0.6	—	μs
Setup time for a repeated START condition	t _{I2SVKH}	0.6	—	μs
Hold time (repeated) START condition (after this period, the first clock pulse is generated)	t _{I2SXKL}	0.6	—	μs
Data setup time	t _{I2DVKH}	100	—	ns
Data hold time: CBUS compatible masters I ² C bus devices	t _{I2DXKL}	— 0 ²	— 0.9 ³	μs
Fall time of both SDA and SCL signals	t _{I2CF} ⁴	—	300	ns
Setup time for STOP condition	t _{I2PVKH}	0.6	—	μs
Bus free time between a STOP and START condition	t _{I2KHDX}	1.3	—	μs
Noise margin at the LOW level for each connected device (including hysteresis)	V _{NL}	0.1 × NVDD	—	V
Noise margin at the HIGH level for each connected device (including hysteresis)	V _{NH}	0.2 × NVDD	—	V

Note:

1. The symbols used for timing specifications follow the pattern of t_{(first two letters of functional block)(signal)(state)(reference)(state)} for inputs and t_{(first two letters of functional block)(reference)(state)(signal)(state)} for outputs. For example, t_{I2DVKH} symbolizes I²C timing (I2) with respect to the time data input signals (D) reach the valid state (V) relative to the t_{I2C} clock reference (K) going to the high (H) state or setup time. Also, t_{I2SXKL} symbolizes I²C timing (I2) for the time that the data with respect to the start condition (S) went invalid (X) relative to the t_{I2C} clock reference (K) going to the low (L) state or hold time. Also, t_{I2PVKH} symbolizes I²C timing (I2) for the time that the data with respect to the stop condition (P) reaching the valid state (V) relative to the t_{I2C} clock reference (K) going to the high (H) state or setup time. For rise and fall times, the latter convention is used with the appropriate letter: R (rise) or F (fall).
2. MPC8314E provides a hold time of at least 300 ns for the SDA signal (referred to the V_{IHmin} of the SCL signal) to bridge the undefined region of the falling edge of SCL.
3. The maximum t_{I2DVKH} has to be met only if the device does not stretch the LOW period (t_{I2CL}) of the SCL signal.
4. MPC8314E does not follow the *I2C-BUS Specifications* version 2.1 regarding the tI2CF AC parameter.

This figure provides the AC test load for the I²C.

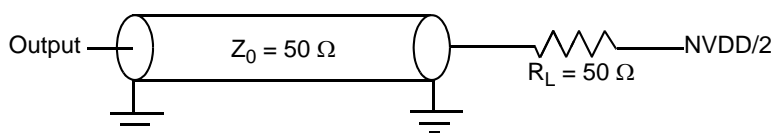

Figure 32. I²C AC Test Load

This figure shows the AC timing diagram for the I²C bus.

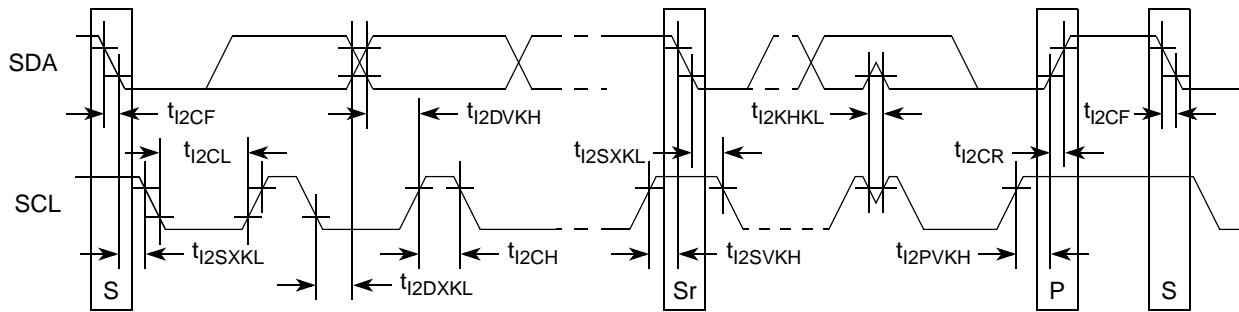

Figure 33. I²C Bus AC Timing Diagram

14 PCI

This section describes the DC and AC electrical specifications for the PCI bus of the MPC8314E.

14.1 PCI DC Electrical Characteristics

This table provides the DC electrical characteristics for the PCI interface.

Table 49. PCI DC Electrical Characteristics ¹

Parameter	Symbol	Test Condition	Min	Max	Unit
High-level input voltage	V_{IH}	$V_{OUT} \geq V_{OH} (\text{min})$ or	$0.5 \times NVDD$	$NVDD + 0.3$	V
Low-level input voltage	V_{IL}	$V_{OUT} \leq V_{OL} (\text{max})$	-0.5	$0.3 \times NVDD$	V
High-level output voltage	V_{OH}	$NVDD = \text{min}$, $I_{OH} = -500 \mu\text{A}$	$0.9 \times NVDD$	—	V
Low-level output voltage	V_{OL}	$NVDD = \text{min}$, $I_{OL} = 1500 \mu\text{A}$	—	$0.1 \times NVDD$	V
Input current	I_{IN}	$0 \text{ V} \leq V_{IN} \leq NVDD$	—	± 10	μA

Note:

1. The symbol V_{IN} , in this case, represents the NV_{IN} symbol referenced in Table 1 and Table 2.

14.2 PCI AC Electrical Specifications

This section describes the general AC timing parameters of the PCI bus. Note that the PCI_CLK or PCI_SYNC_IN signal is used as the PCI input clock depending on whether the MPC8314E is configured as a host or agent device. This table shows the PCI AC timing specifications at 66 MHz.

Table 50. PCI AC Timing Specifications at 66 MHz

Parameter	Symbol ¹	Min	Max	Unit	Note
Clock to output valid	t_{PCKHOV}	—	6.0	ns	2
Output hold from clock	t_{PCKHOX}	1	—	ns	2
Clock to output high impedance	t_{PCKHOZ}	—	14	ns	2, 3
Input setup to clock	t_{PCIVKH}	3.3	—	ns	2, 4

Table 50. PCI AC Timing Specifications at 66 MHz (continued)

Parameter	Symbol ¹	Min	Max	Unit	Note
Input hold from clock	t_{PCIXKH}	0	—	ns	2, 4

Note:

- Note that the symbols used for timing specifications herein follow the pattern of $t_{(first\ two\ letters\ of\ functional\ block)(signal)(state)\ (reference)(state)}$ for inputs and $t_{(first\ two\ letters\ of\ functional\ block)(reference)(state)(signal)(state)}$ for outputs. For example, t_{PCIVKH} symbolizes PCI timing (PC) with respect to the time the input signals (I) reach the valid state (V) relative to the PCI_SYNC_IN clock, t_{SYS} , reference (K) going to the high (H) state or setup time. Also, t_{PCRHFV} symbolizes PCI timing (PC) with respect to the time hard reset (R) went high (H) relative to the frame signal (F) going to the valid (V) state.
- See the timing measurement conditions in the *PCI 2.3 Local Bus Specifications*.
- For purposes of active/float timing measurements, the Hi-Z or off state is defined to be when the total current delivered through the component pin is less than or equal to the leakage current specification.
- Input timings are measured at the pin.

This table shows the PCI AC Timing Specifications at 33 MHz.

Table 51. PCI AC Timing Specifications at 33 MHz

Parameter	Symbol ¹	Min	Max	Unit	Note
Clock to output valid	t_{PCKHOV}	—	11	ns	2
Output hold from clock	t_{PCKHOX}	2	—	ns	2
Clock to output high impedance	t_{PCKHOZ}	—	14	ns	2, 3
Input setup to clock	t_{PCIVKH}	4.0	—	ns	2, 4
Input hold from clock	t_{PCIXKH}	0	—	ns	2, 4

Note:

- Note that the symbols used for timing specifications follow the pattern of $t_{(first\ two\ letters\ of\ functional\ block)(signal)(state)\ (reference)(state)}$ for inputs and $t_{(first\ two\ letters\ of\ functional\ block)(reference)(state)(signal)(state)}$ for outputs. For example, t_{PCIVKH} symbolizes PCI timing (PC) with respect to the time the input signals (I) reach the valid state (V) relative to the PCI_SYNC_IN clock, t_{SYS} , reference (K) going to the high (H) state or setup time. Also, t_{PCRHFV} symbolizes PCI timing (PC) with respect to the time hard reset (R) went high (H) relative to the frame signal (F) going to the valid (V) state.
- See the timing measurement conditions in the *PCI 2.3 Local Bus Specifications*.
- For purposes of active/float timing measurements, the Hi-Z or off state is defined to be when the total current delivered through the component pin is less than or equal to the leakage current specification.
- Input timings are measured at the pin.

This figure provides the AC test load for PCI.

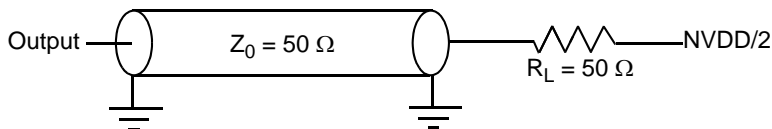

Figure 34. PCI AC Test Load

This figure shows the PCI input AC timing conditions.

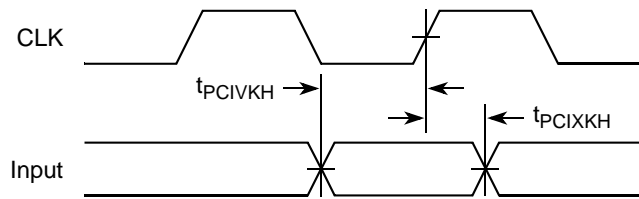

Figure 35. PCI Input AC Timing Measurement Conditions

This figure shows the PCI output AC timing conditions.

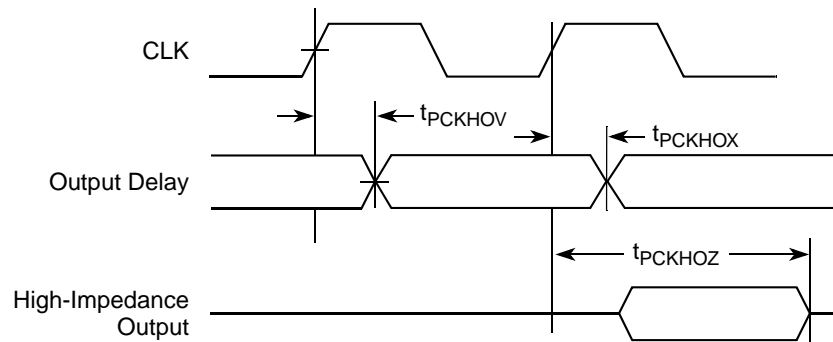

Figure 36. PCI Output AC Timing Measurement Condition

15 High-Speed Serial Interfaces (HSSI)

This section describes the common portion of SerDes DC electrical specifications, which is the DC requirement for SerDes Reference Clocks. The SerDes data lane's transmitter and receiver reference circuits are also shown.

15.1 Signal Terms Definition

The SerDes utilizes differential signaling to transfer data across the serial link. This section defines terms used in the description and specification of differential signals.

Figure 37 shows how the signals are defined. For illustration purpose, only one SerDes lane is used for description. The figure shows waveform for either a transmitter output (TX_n and \overline{TX}_n) or a receiver input (RX_n and \overline{RX}_n). Each signal swings between A Volts and B Volts where $A > B$.

Using this waveform, the definitions are as follows. To simplify illustration, the following definitions assume that the SerDes transmitter and receiver operate in a fully symmetrical differential signaling environment.

1. Single-Ended Swing

The transmitter output signals and the receiver input signals TX_n , \overline{TX}_n , RX_n and \overline{RX}_n each have a peak-to-peak swing of $A - B$ Volts. This is also referred as each signal wire's Single-Ended Swing.

2. Differential Output Voltage, V_{OD} (or Differential Output Swing):

The Differential Output Voltage (or Swing) of the transmitter, V_{OD} , is defined as the difference of the two complimentary output voltages: $V_{TXn} - V_{\overline{TXn}}$. The V_{OD} value can be either positive or negative.

3. **Differential Input Voltage, V_{ID} (or Differential Input Swing):**

The Differential Input Voltage (or Swing) of the receiver, V_{ID} , is defined as the difference of the two complimentary input voltages: $V_{RXn} - V_{\overline{RXn}}$. The V_{ID} value can be either positive or negative.

4. **Differential Peak Voltage, V_{DIFFp}**

The peak value of the differential transmitter output signal or the differential receiver input signal is defined as Differential Peak Voltage, $V_{DIFFp} = |A - B|$ Volts.

5. **Differential Peak-to-Peak, $V_{DIFFp-p}$**

Because the differential output signal of the transmitter and the differential input signal of the receiver each range from $A - B$ to $-(A - B)$ Volts, the peak-to-peak value of the differential transmitter output signal or the differential receiver input signal is defined as Differential Peak-to-Peak Voltage, $V_{DIFFp-p} = 2 * V_{DIFFp} = 2 * |A - B|$ Volts, which is twice of differential swing in amplitude, or twice of the differential peak. For example, the output differential peak-peak voltage can also be calculated as $V_{TX-DIFFp-p} = 2 * |V_{OD}|$.

6. **Differential Waveform**

The differential waveform is constructed by subtracting the inverting signal (\overline{TXn} , for example) from the non-inverting signal (TXn , for example) within a differential pair. There is only one signal trace curve in a differential waveform. The voltage represented in the differential waveform is not referenced to ground. Refer to [Figure 46](#) as an example for differential waveform.

7. **Common Mode Voltage, V_{cm}**

The Common Mode Voltage is equal to one half of the sum of the voltages between each conductor of a balanced interchange circuit and ground. In this example, for SerDes output, $V_{cm_out} = (V_{TXn} + V_{\overline{TXn}}) / 2 = (A + B) / 2$, which is the arithmetic mean of the two complimentary output voltages within a differential pair. In a system, the common mode voltage may often differ from one component's output to the other's input. Sometimes, it may be even different between the receiver input and driver output circuits within the same component. It's also referred as the DC offset in some occasion.

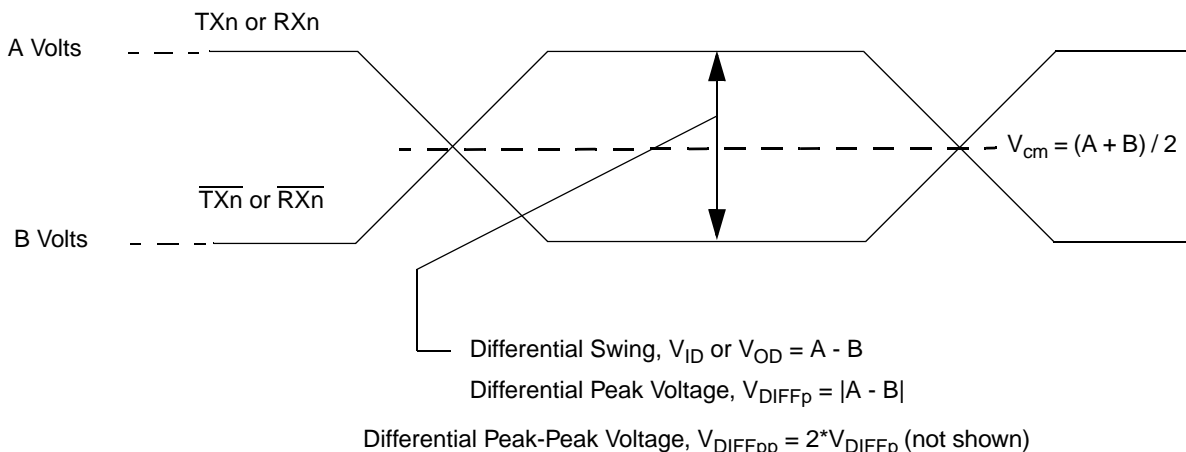

Figure 37. Differential Voltage Definitions for Transmitter or Receiver

To illustrate these definitions using real values, consider the case of a CML (Current Mode Logic) transmitter that has a common mode voltage of 2.25 V and each of its outputs, TD and $\overline{\text{TD}}$, has a swing that goes between 2.5V and 2.0V. Using these values, the peak-to-peak voltage swing of each signal (TD or $\overline{\text{TD}}$) is 500 mV p-p, which is referred as the single-ended swing for each signal. In this example, since the differential signaling environment is fully symmetrical, the transmitter output's differential swing (V_{OD}) has the same amplitude as each signal's single-ended swing. The differential output signal ranges between 500 mV and -500 mV, in other words, V_{OD} is 500 mV in one phase and -500 mV in the other phase. The peak differential voltage (V_{DIFFp}) is 500 mV. The peak-to-peak differential voltage ($V_{\text{DIFFp-p}}$) is 1000 mV p-p.

15.2 SerDes Reference Clocks

The SerDes reference clock inputs are applied to an internal PLL whose output creates the clock used by the corresponding SerDes lanes. The SerDes reference clocks input is SD_REF_CLK and $\overline{\text{SD_REF_CLK}}$ for PCI Express and SGMII interface.

The following sections describe the SerDes reference clock requirements and some application information.

15.2.1 SerDes Reference Clock Receiver Characteristics

Figure 38 shows a receiver reference diagram of the SerDes reference clocks.

- The supply voltage requirements for XCOREVDD are specified in Table 1 and Table 2.
- SerDes Reference Clock Receiver Reference Circuit Structure
 - The SD_REF_CLK and $\overline{\text{SD_REF_CLK}}$ are internally AC-coupled differential inputs as shown in Figure 38. Each differential clock input (SD_REF_CLK or $\overline{\text{SD_REF_CLK}}$) has a 50- Ω termination to XCOREVSS followed by on-chip AC-coupling.
 - The external reference clock driver must be able to drive this termination.
 - The SerDes reference clock input can be either differential or single-ended. Refer to the Differential Mode and Single-ended Mode description below for further detailed requirements.

- The maximum average current requirement that also determines the common mode voltage range
 - When the SerDes reference clock differential inputs are DC coupled externally with the clock driver chip, the maximum average current allowed for each input pin is 8mA. In this case, the exact common mode input voltage is not critical as long as it is within the range allowed by the maximum average current of 8 mA (refer to the following bullet for more detail), since the input is AC-coupled on-chip.
 - This current limitation sets the maximum common mode input voltage to be less than 0.4V ($0.4V/50 = 8mA$) while the minimum common mode input level is 0.1V above XCOREVSS. For example, a clock with a 50/50 duty cycle can be produced by a clock driver with output driven by its current source from 0mA to 16mA (0-0.8V), such that each phase of the differential input has a single-ended swing from 0V to 800mV with the common mode voltage at 400mV.
 - If the device driving the $\overline{SD_REF_CLK}$ and SD_REF_CLK inputs cannot drive 50 ohms to XCOREVSS DC, or it exceeds the maximum input current limitations, then it must be AC-coupled off-chip.
- The input amplitude requirement
 - This requirement is described in detail in the following sections.

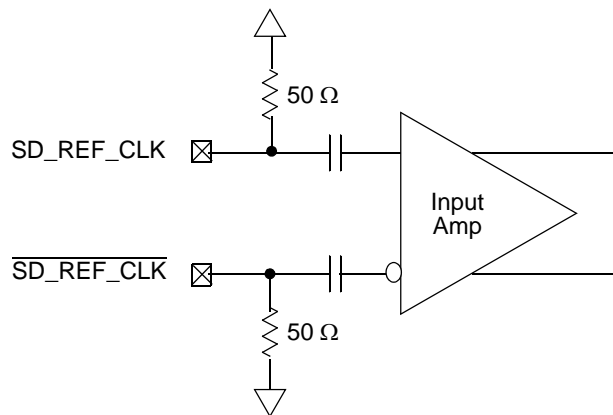

Figure 38. Receiver of SerDes Reference Clocks

15.2.2 DC Level Requirement for SerDes Reference Clocks

The DC level requirement for the MPC8315E SerDes reference clock inputs is different depending on the signaling mode used to connect the clock driver chip and SerDes reference clock inputs as described below.

- **Differential Mode**
 - The input amplitude of the differential clock must be between 400mV and 1600mV differential peak-peak (or between 200mV and 800mV differential peak). In other words, each signal wire of the differential pair must have a single-ended swing less than 800mV and greater than 200mV. This requirement is the same for both external DC-coupled or AC-coupled connection.
 - For **external DC-coupled** connection, as described in section 15.2.1, the maximum average current requirements sets the requirement for average voltage (common mode voltage) to be

between 100 mV and 400 mV. Figure 39 shows the SerDes reference clock input requirement for DC-coupled connection scheme.

- For **external AC-coupled** connection, there is no common mode voltage requirement for the clock driver. Since the external AC-coupling capacitor blocks the DC level, the clock driver and the SerDes reference clock receiver operate in different common mode voltages. The SerDes reference clock receiver in this connection scheme has its common mode voltage set to XCOREVSS. Each signal wire of the differential inputs is allowed to swing below and above the common mode voltage (XCOREVSS). Figure 40 shows the SerDes reference clock input requirement for AC-coupled connection scheme.

• **Single-ended Mode**

- The reference clock can also be single-ended. The SD_REF_CLK input amplitude (single-ended swing) must be between 400mV and 800mV peak-peak (from Vmin to Vmax) with SD_REF_CLK either left unconnected or tied to ground.
- The SD_REF_CLK input average voltage must be between 200 and 400 mV. Figure 41 shows the SerDes reference clock input requirement for single-ended signaling mode.
- To meet the input amplitude requirement, the reference clock inputs might need to be DC or AC-coupled externally. For the best noise performance, the reference of the clock could be DC or AC-coupled into the unused phase (SD_REF_CLK) through the same source impedance as the clock input (SD_REF_CLK) in use.

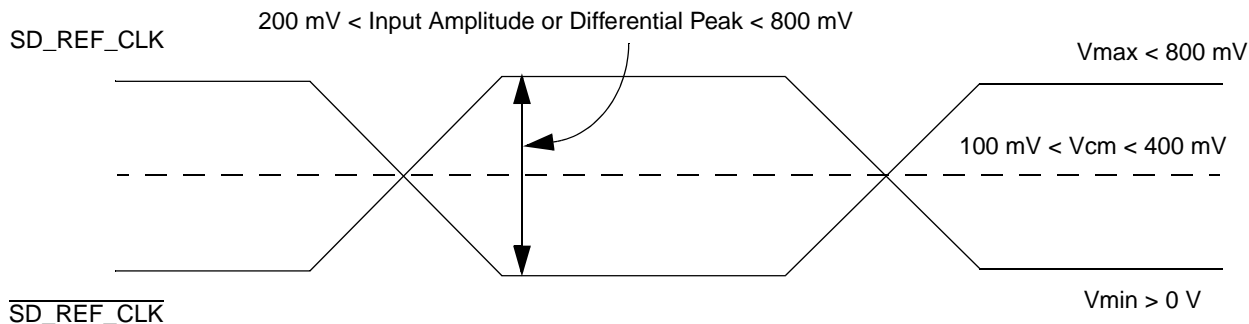

Figure 39. Differential Reference Clock Input DC Requirements (External DC-Coupled)

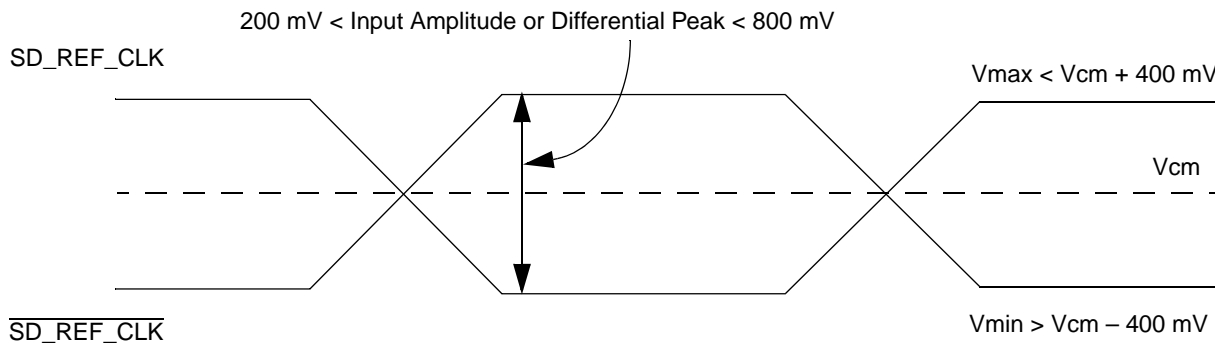

Figure 40. Differential Reference Clock Input DC Requirements (External AC-Coupled)

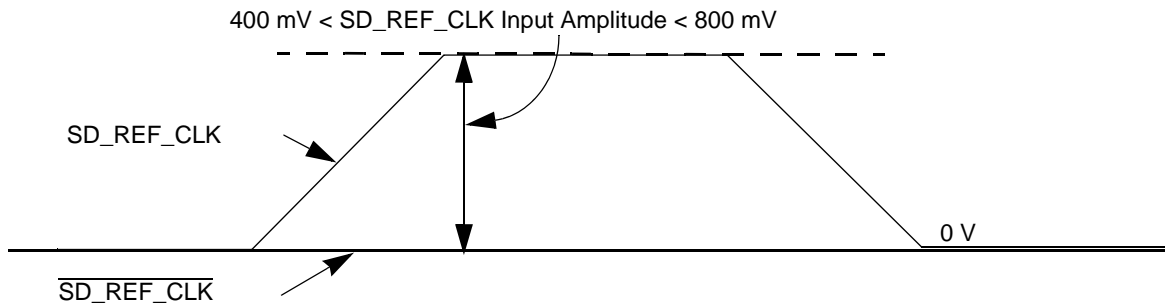

Figure 41. Single-Ended Reference Clock Input DC Requirements

15.2.3 Interfacing With Other Differential Signaling Levels

With on-chip termination to XCOREVSS, the differential reference clocks inputs are HCSL (High-Speed Current Steering Logic) compatible DC-coupled.

Many other low voltage differential type outputs like LVDS (Low Voltage Differential Signaling) can be used but may need to be AC-coupled due to the limited common mode input range allowed (100 to 400 mV) for DC-coupled connection.

LVPECL outputs can produce signal with too large amplitude and may need to be DC-biased at clock driver output first, then followed with series attenuation resistor to reduce the amplitude, in addition to AC-coupling.

NOTE

Figure 42–Figure 45 are for conceptual reference only. Due to the fact that clock driver chip's internal structure, output impedance and termination requirements are different between various clock driver chip manufacturers, it's very possible that the clock circuit reference designs provided by clock driver chip vendor are different from what is shown below. They might also vary from one vendor to the other. Therefore, Freescale Semiconductor can neither provide the optimal clock driver reference circuits, nor guarantee the correctness of the following clock driver connection reference circuits. The system designer is recommended to contact the selected clock driver chip vendor for the optimal reference circuits with the MPC8315E SerDes reference clock receiver requirement provided in this document.

This figure shows the SerDes reference clock connection reference circuits for HCSL type clock driver. It assumes that the DC levels of the clock driver chip is compatible with MPC8315E SerDes reference clock input's DC requirement.

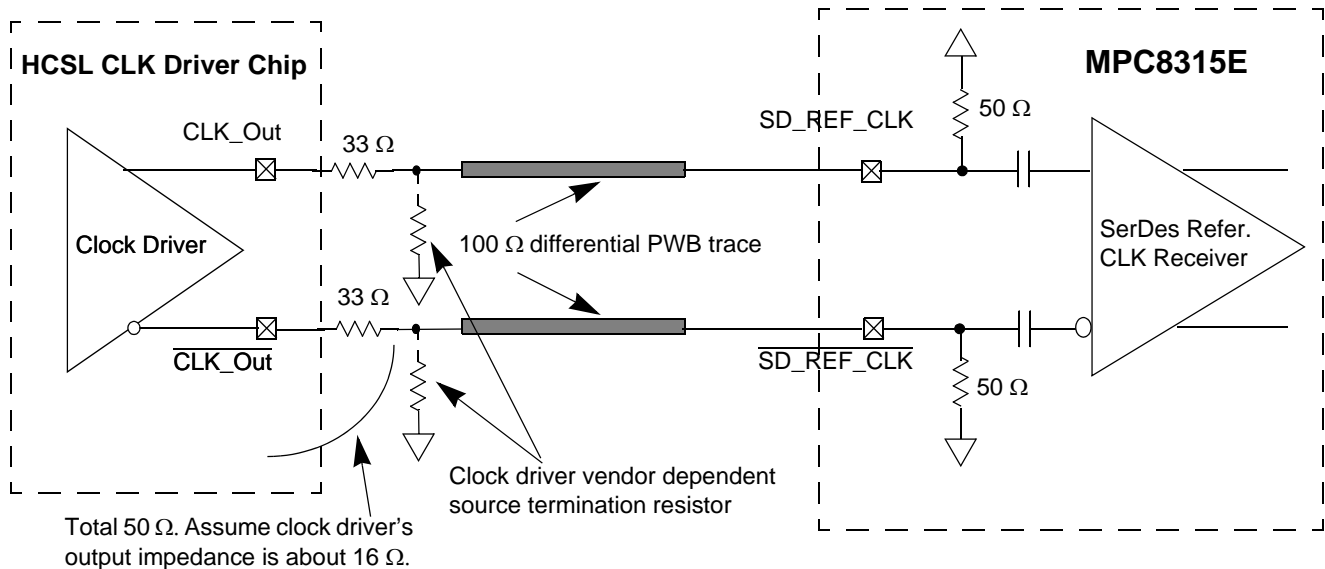

Figure 42. DC-Coupled Differential Connection with HCSL Clock Driver (Reference Only)

This figure shows the SerDes reference clock connection reference circuits for LVDS type clock driver. Since LVDS clock driver's common mode voltage is higher than the MPC8315E SerDes reference clock input's allowed range (100 to 400mV), AC-coupled connection scheme must be used. It assumes the LVDS output driver features 50-ohm termination resistor. It also assumes that the LVDS transmitter establishes its own common mode level without relying on the receiver or other external component.

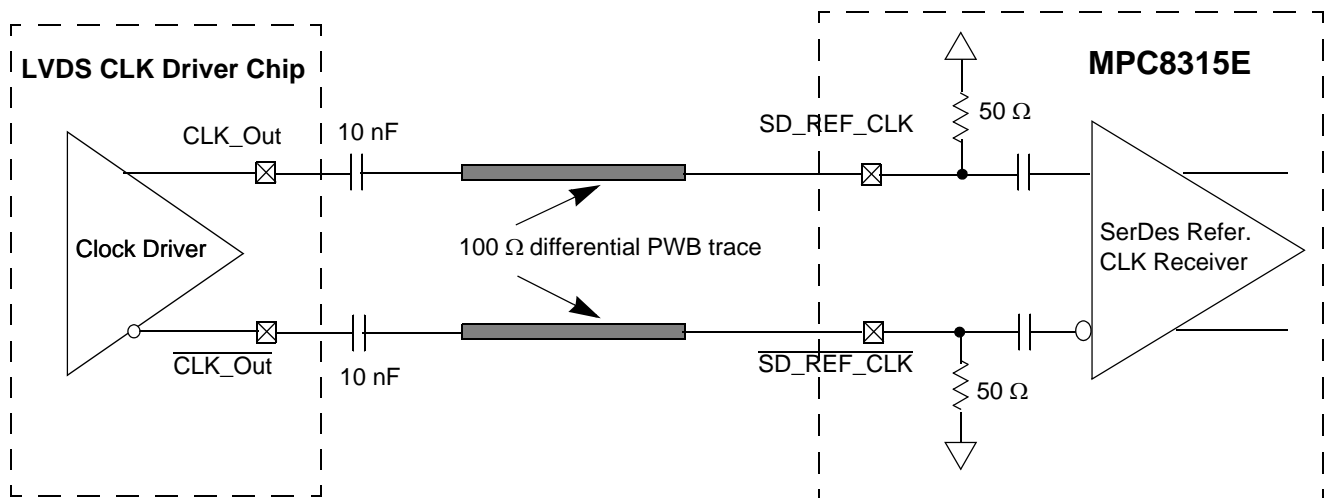

Figure 43. AC-Coupled Differential Connection with LVDS Clock Driver (Reference Only)

Figure 44 shows the SerDes reference clock connection reference circuits for LVPECL type clock driver. Since LVPECL driver's DC levels (both common mode voltages and output swing) are incompatible with MPC8315E SerDes reference clock input's DC requirement, AC-coupling has to be used. Figure 44

assumes that the LVPECL clock driver's output impedance is 50Ω . R1 is used to DC-bias the LVPECL outputs prior to AC-coupling. Its value could be ranged from 140Ω to 240Ω depending on clock driver vendor's requirement. R2 is used together with the SerDes reference clock receiver's 50Ω termination resistor to attenuate the LVPECL output's differential peak level such that it meets the MPC8315E SerDes reference clock's differential input amplitude requirement (between 200mV and 800mV differential peak). For example, if the LVPECL output's differential peak is 900mV and the desired SerDes reference clock input amplitude is selected as 600mV , the attenuation factor is 0.67 , which requires $R2 = 25\Omega$. Please consult clock driver chip manufacturer to verify whether this connection scheme is compatible with a particular clock driver chip.

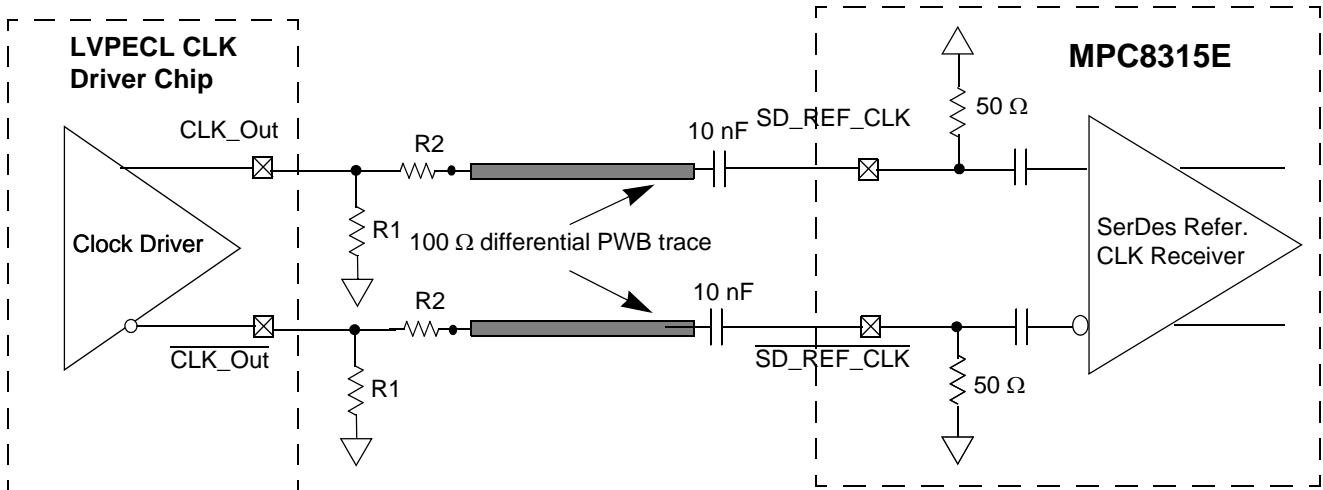

Figure 44. AC-Coupled Differential Connection with LVPECL Clock Driver (Reference Only)

This figure shows the SerDes reference clock connection reference circuits for a single-ended clock driver. It assumes the DC levels of the clock driver are compatible with MPC8315E SerDes reference clock input's DC requirement.

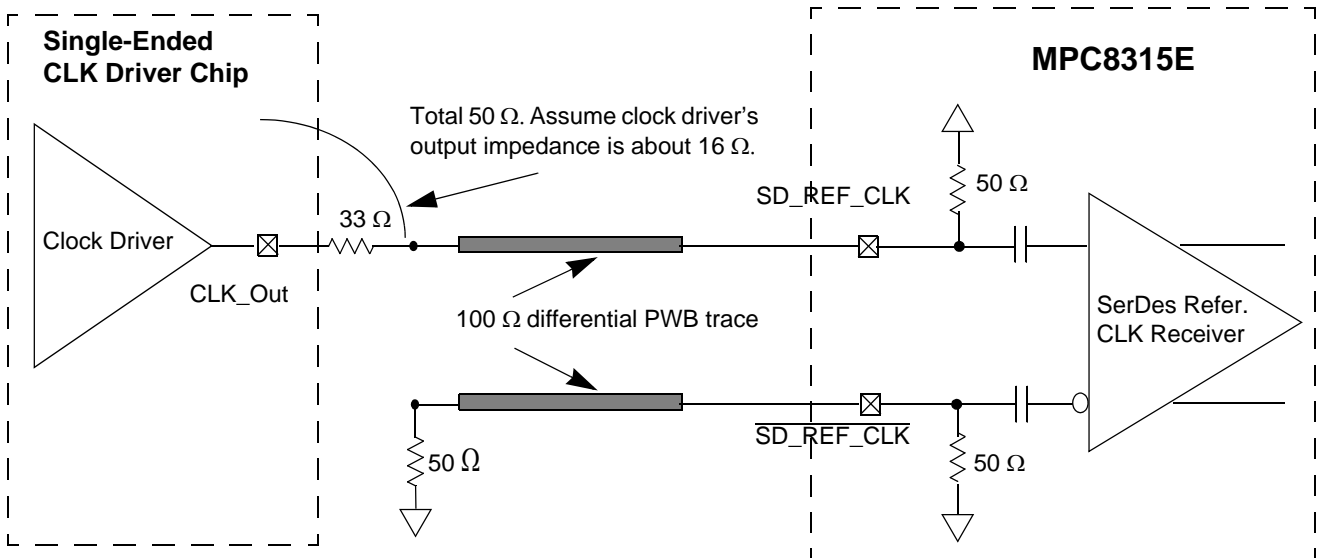

Figure 45. Single-Ended Connection (Reference Only)

15.2.4 AC Requirements for SerDes Reference Clocks

The clock driver selected should provide a high quality reference clock with low phase noise and cycle-to-cycle jitter. Phase noise less than 100KHz can be tracked by the PLL and data recovery loops and is less of a problem. Phase noise above 15MHz is filtered by the PLL. The most problematic phase noise occurs in the 1-15MHz range. The source impedance of the clock driver should be $50\ \Omega$ to match the transmission line and reduce reflections which are a source of noise to the system.

This table describes some AC parameters common to SGMII and PCI Express protocols.

Table 52. SerDes Reference Clock Common AC Parameters

At recommended operating conditions with XCOREVDD= 1.0V \pm 5%

Parameter	Symbol	Min	Max	Unit	Note
Rising Edge Rate	Rise Edge Rate	1.0	4.0	V/ns	2, 3
Falling Edge Rate	Fall Edge Rate	1.0	4.0	V/ns	2, 3
Differential Input High Voltage	V_{IH}	+200	—	mV	2
Differential Input Low Voltage	V_{IL}	—	-200	mV	2
Rising edge rate (SDn_REF_CLK) to falling edge rate (SDn_REF_CLK) matching	Rise-Fall Matching	—	20	%	1, 4

Note:

1. Measurement taken from single ended waveform.
2. Measurement taken from differential waveform.
3. Measured from -200 mV to +200 mV on the differential waveform (derived from $\overline{SDn_REF_CLK}$ minus SDn_REF_CLK). The signal must be monotonic through the measurement region for rise and fall time. The 400 mV measurement window is centered on the differential zero crossing. See [Figure 46](#).
4. Matching applies to rising edge rate for SDn_REF_CLK and falling edge rate for $\overline{SDn_REF_CLK}$. It is measured using a 200 mV window centered on the median cross point where SDn_REF_CLK rising meets $\overline{SDn_REF_CLK}$ falling. The median cross point is used to calculate the voltage thresholds the oscilloscope is to use for the edge rate calculations. The Rise Edge Rate of SDn_REF_CLK should be compared to the Fall Edge Rate of $\overline{SDn_REF_CLK}$, the maximum allowed difference should not exceed 20% of the slowest edge rate. See [Figure 47](#).

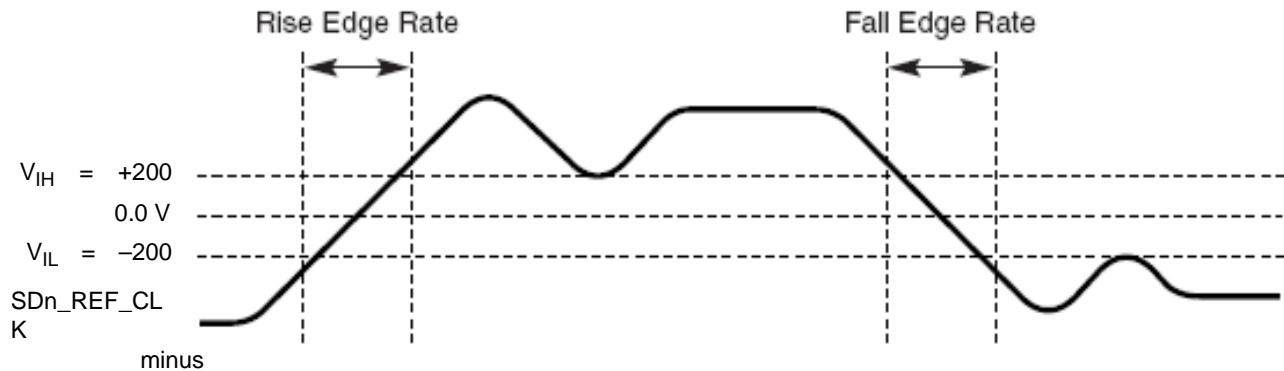

Figure 46. Differential Measurement Points for Rise and Fall Time

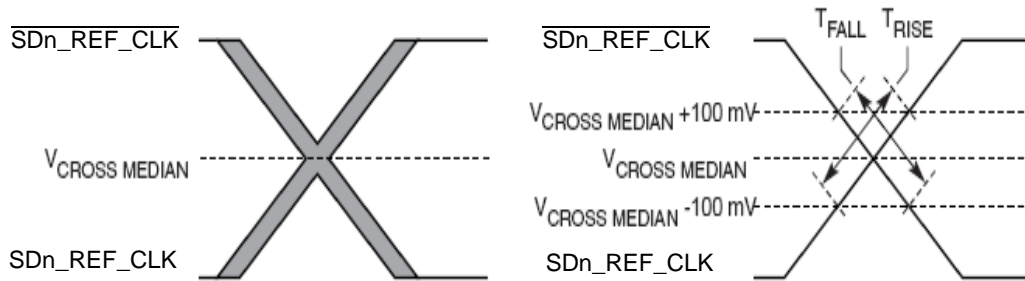

Figure 47. Single-Ended Measurement Points for Rise and Fall Time Matching

The other detailed AC requirements of the SerDes Reference Clocks is defined by each interface protocol based on application usage. Refer to the following sections for detailed information:

- [Section 9.5.2, “AC Requirements for SGMII SD_REF_CLK and SD_REF_CLK”](#)
- [Section 16.2, “AC Requirements for PCI Express SerDes Clocks”](#)

15.2.4.1 Spread Spectrum Clock

SD_REF_CLK/SD_REF_CLK are not intended to be used with, and should not be clocked by, a spread spectrum clock source.

15.3 SerDes Transmitter and Receiver Reference Circuits

This figure shows the reference circuits for SerDes data lane’s transmitter and receiver.

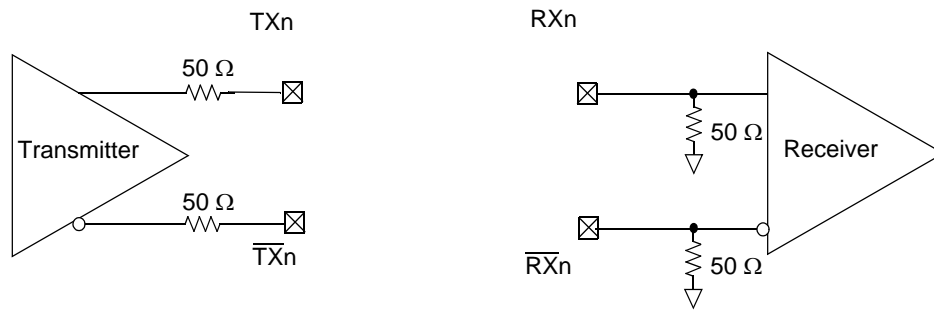

Figure 48. SerDes Transmitter and Receiver Reference Circuits

The DC and AC specification of SerDes data lanes are defined in each interface protocol section below (PCI Express or SGMII) in this document based on the application usage:

- [Section 9.5, “SGMII Interface Electrical Characteristics”](#)
- [Section 16, “PCI Express”](#)

Note that external AC Coupling capacitor is required for the above two serial transmission protocols with the capacitor value defined in specification of each protocol section.

16 PCI Express

This section describes the DC and AC electrical specifications for the PCI Express bus of the MPC8315E.

16.1 DC Requirements for PCI Express SD_REF_CLK and SD_REF_CLK

For more information, see [Section 15.2, “SerDes Reference Clocks.”](#)

16.2 AC Requirements for PCI Express SerDes Clocks

This table lists the PCI Express SerDes clock AC requirements.

Table 53. SD_REF_CLK and SD_REF_CLK AC Requirements

Symbol	Parameter Description	Min	Typ	Max	Unit	Note
t_{REF}	REFCLK cycle time	—	10	—	ns	—
t_{REFCJ}	REFCLK cycle-to-cycle jitter. Difference in the period of any two adjacent REFCLK cycles.	—	—	100	ps	—
t_{REFPJ}	Phase jitter. Deviation in edge location with respect to mean edge location.	-50	—	50	ps	—

16.3 Clocking Dependencies

The ports on the two ends of a link must transmit data at a rate that is within 600 parts per million (ppm) of each other at all times. This is specified to allow bit rate clock sources with a ± 300 ppm tolerance.

16.4 Physical Layer Specifications

Following is a summary of the specifications for the physical layer of PCI Express on this device. For further details as well as the specifications of the transport and data link layer please use the *PCI Express Base Specification*, Rev. 1.0a.

16.4.1 Differential Transmitter (TX) Output

This table defines the specifications for the differential output at all transmitters (TXs). The parameters are specified at the component pins.

Table 54. Differential Transmitter (TX) Output Specifications

Parameter	Symbol	Comments	Min	Typical	Max	Unit	Note
Unit interval	UI	Each UI is 400 ps \pm 300 ppm. UI does not account for Spread Spectrum Clock dictated variations.	399.88	400	400.12	ps	1
Differential peak-to-peak output voltage	$V_{TX-DIFFp-p}$	$V_{TX-DIFFp-p} = 2 * V_{TX-D+} - V_{TX-D-} $	0.8	—	1.2	V	2

Table 54. Differential Transmitter (TX) Output Specifications (continued)

Parameter	Symbol	Comments	Min	Typical	Max	Unit	Note
De-Emphasized differential output voltage (ratio)	$V_{TX-DE-RATIO}$	Ratio of the $V_{TX-DIFFp-p}$ of the second and following bits after a transition divided by the $V_{TX-DIFFp-p}$ of the first bit after a transition.	-3.0	-3.5	-4.0	dB	2
Minimum TX eye width	T_{TX-EYE}	The maximum Transmitter jitter can be derived as $T_{TX-MAX-JITTER} = 1 - U_{TX-EYE} = 0.3 UI$.	0.70	—	—	UI	2, 3
Maximum time between the jitter median and maximum deviation from the median	$T_{TX-EYE-MEDIAN-to-MAX-JITTER}$	Jitter is defined as the measurement variation of the crossing points ($V_{TX-DIFFp-p} = 0 V$) in relation to a recovered TX UI. A recovered TX UI is calculated over 3500 consecutive unit intervals of sample data. Jitter is measured using all edges of the 250 consecutive UI in the center of the 3500 UI used for calculating the TX UI.	—	—	0.15	UI	2, 3
D+/D- TX output rise/fall time	$T_{TX-RISE}, T_{TX-FALL}$	—	0.125	—	—	UI	2, 5
RMS AC peak common mode output voltage	$V_{TX-CM-ACp}$	$V_{TX-CM-ACp} = \text{RMS}(V_{TXD+} + V_{TXD-} /2 - V_{TX-CM-DC})$ $V_{TX-CM-DC} = DC_{(avg)}$ of $ V_{TX-D+} + V_{TX-D-} /2$	—	—	20	mV	2
Absolute delta of DC common mode voltage during L0 and electrical idle	$V_{TX-CM-DC- ACTIVE-IDLE-DELTA}$	$ V_{TX-CM-DC} \text{ (during L0)} - V_{TX-CM-Idle-DC} \text{ (During Electrical Idle)} \leq 100 \text{ mV}$ $V_{TX-CM-DC} = DC_{(avg)}$ of $ V_{TX-D+} + V_{TX-D-} /2$ [L0] $V_{TX-CM-Idle-DC} = DC_{(avg)}$ of $ V_{TX-D+} + V_{TX-D-} /2$ [Electrical Idle]	0	—	100	mV	2
Absolute delta of DC common mode between D+ and D-	$V_{TX-CM-DC-LINE-DELTA}$	$ V_{TX-CM-DC-D+} - V_{TX-CM-DC-D-} \leq 25 \text{ mV}$ $V_{TX-CM-DC-D+} = DC_{(avg)}$ of $ V_{TX-D+} $ $V_{TX-CM-DC-D-} = DC_{(avg)}$ of $ V_{TX-D-} $	0	—	25	mV	2
Electrical idle differential peak output voltage	$V_{TX-IDLE-DIFFp}$	$V_{TX-IDLE-DIFFp} = V_{TX-IDLE-D+} - V_{TX-IDLE-D-} \leq 20 \text{ mV}$	0	—	20	mV	2
Amount of voltage change allowed during receiver detection	$V_{TX-RCV-DETECT}$	The total amount of voltage change that a transmitter can apply to sense whether a low impedance Receiver is present.	—	—	600	mV	6
TX DC common mode voltage	$V_{TX-DC-CM}$	The allowed DC Common Mode voltage under any conditions.	—	—	3.6	V	6
TX short circuit current limit	$I_{TX-SHORT}$	The total current the Transmitter can provide when shorted to its ground	—	—	90	mA	—
Minimum time spent in electrical idle	$T_{TX-IDLE-MIN}$	Minimum time a Transmitter must be in Electrical Idle Utilized by the Receiver to start looking for an Electrical Idle Exit after successfully receiving an Electrical Idle ordered set	50	—	—	UI	—

Table 54. Differential Transmitter (TX) Output Specifications (continued)

Parameter	Symbol	Comments	Min	Typical	Max	Unit	Note
Maximum time to transition to a valid electrical idle after sending an electrical idle ordered set	$T_{TX-IDLE-SET-TO-IDLE}$	After sending an Electrical Idle ordered set, the Transmitter must meet all Electrical Idle Specifications within this time. This is considered a debounce time for the Transmitter to meet Electrical Idle after transitioning from L0.	—	—	20	UI	—
Maximum time to transition to valid TX specifications after leaving an electrical idle condition	$T_{TX-IDLE-TO-DIFF-DATA}$	Maximum time to meet all TX specifications when transitioning from Electrical Idle to sending differential data. This is considered a debounce time for the TX to meet all TX specifications after leaving Electrical Idle	—	—	20	UI	—
Differential return loss	$RL_{TX-DIFF}$	Measured over 50 MHz to 1.25 GHz.	12	—	—	dB	4
Common mode return loss	RL_{TX-CM}	Measured over 50 MHz to 1.25 GHz.	6	—	—	dB	4
DC differential TX impedance	$Z_{TX-DIFF-DC}$	TX DC Differential mode Low Impedance	80	100	120	Ω	—
Transmitter DC impedance	Z_{TX-DC}	Required TX D+ as well as D- DC Impedance during all states	40	—	—	Ω	—
Lane-to-Lane output skew	$L_{TX-SKEW}$	Static skew between any two Transmitter Lanes within a single Link	—	—	500 + 2 UI	ps	—
AC coupling capacitor	C_{TX}	All Transmitters shall be AC coupled. The AC coupling is required either within the media or within the transmitting component itself.	75	—	200	nF	8
Crosslink random timeout	$T_{crosslink}$	This random timeout helps resolve conflicts in crosslink configuration by eventually resulting in only one Downstream and one Upstream Port.	0	—	1	ms	7

Note:

1. No test load is necessarily associated with this value.
2. Specified at the measurement point into a timing and voltage compliance test load as shown in [Figure 51](#) and measured over any 250 consecutive TX UIs. (Also refer to the transmitter compliance eye diagram shown in [Figure 49](#).)
3. A $T_{TX-EYE} = 0.70$ UI provides for a total sum of deterministic and random jitter budget of $T_{TX-JITTER-MAX} = 0.30$ UI for the transmitter collected over any 250 consecutive TX UIs. The $T_{TX-EYE-MEDIAN-to-MAX-JITTER}$ median is less than half of the total TX jitter budget collected over any 250 consecutive TX UIs. It should be noted that the median is not the same as the mean. The jitter median describes the point in time where the number of jitter points on either side is approximately equal as opposed to the averaged time value.
4. The transmitter input impedance shall result in a differential return loss greater than or equal to 12 dB and a common mode return loss greater than or equal to 6 dB over a frequency range of 50 MHz to 1.25 GHz. This input impedance requirement applies to all valid input levels. The reference impedance for return loss measurements is 50 Ω to ground for both the D+ and D- line (that is, as measured by a vector network analyzer with 50- Ω probes, see [Figure 51](#)). Note that the series capacitors, C_{TX} , is optional for the return loss measurement.
5. Measured between 20%–80% at transmitter package pins into a test load as shown in [Figure 51](#) for both V_{TX-D+} and V_{TX-D-} .
6. See Section 4.3.1.8 of the *PCI Express Base Specifications, Rev 1.0a*.
7. See Section 4.2.6.3 of the *PCI Express Base Specifications, Rev 1.0a*.
8. MPC8315E SerDes transmitter does not have C_{TX} built-in. An external AC Coupling capacitor is required

16.4.2 Transmitter Compliance Eye Diagrams

The TX eye diagram in [Figure 49](#) is specified using the passive compliance/test measurement load (see [Figure 51](#)) in place of any real PCI Express interconnect + RX component. There are two eye diagrams that must be met for the transmitter. Both diagrams must be aligned in time using the jitter median to locate the center of the eye diagram. The different eye diagrams differ in voltage depending on whether it is a transition bit or a de-emphasized bit. The exact reduced voltage level of the de-emphasized bit is always relative to the transition bit.

The eye diagram must be valid for any 250 consecutive UIs.

A recovered TX UI is calculated over 3500 consecutive unit intervals of sample data. The eye diagram is created using all edges of the 250 consecutive UI in the center of the 3500 UI used for calculating the TX UI.

NOTE

It is recommended that the recovered TX UI be calculated using all edges in the 3500 consecutive UI interval with a fit algorithm using a minimization merit function (that is, least squares and median deviation fits).

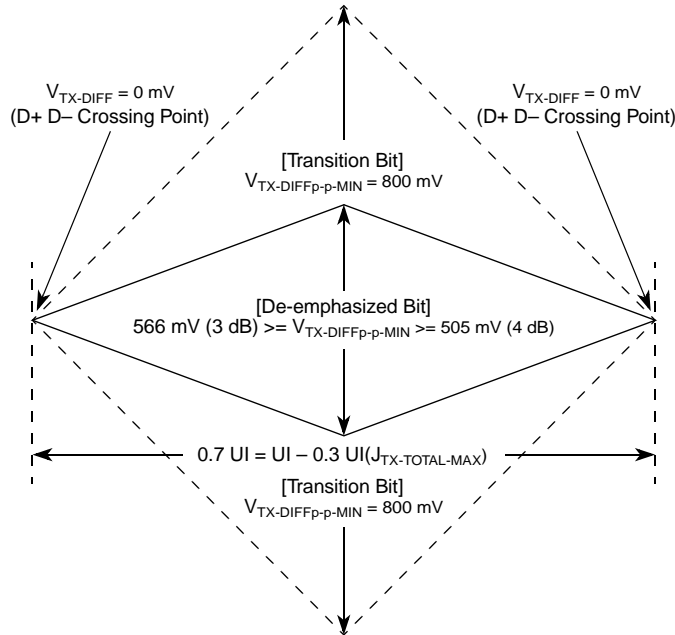

Figure 49. Minimum Transmitter Timing and Voltage Output Compliance Specifications

16.4.3 Differential Receiver (RX) Input Specifications

This table defines the specifications for the differential input at all receivers (RXs). The parameters are specified at the component pins.

Table 55. Differential Receiver (RX) Input Specifications

Parameter	Symbol	Comments	Min	Typical	Max	Unit	Note
Unit interval	UI	Each UI is 400 ps \pm 300 ppm. UI does not account for Spread Spectrum Clock dictated variations.	399.88	400	400.12	ps	1
Differential peak-to-peak output voltage	$V_{RX-DIFFp-p}$	$V_{RX-DIFFp-p} = 2 * V_{RX-D+} - V_{RX-D-} $	0.175	—	1.200	V	2
Minimum receiver eye width	T_{RX-EYE}	The maximum interconnect media and Transmitter jitter that can be tolerated by the Receiver can be derived as $T_{RX-MAX-JITTER} = 1 - U_{RX-EYE} = 0.6$ UI.	0.4	—	—	UI	2, 3
Maximum time between the jitter median and maximum deviation from the median.	$T_{RX-EYE-MEDIAN-to-MAX-JITTER}$	Jitter is defined as the measurement variation of the crossing points ($V_{RX-DIFFp-p} = 0$ V) in relation to a recovered TX UI. A recovered TX UI is calculated over 3500 consecutive unit intervals of sample data. Jitter is measured using all edges of the 250 consecutive UI in the center of the 3500 UI used for calculating the TX UI.	—	—	0.3	UI	2, 3, 7
AC peak common mode input voltage	$V_{RX-CM-ACp}$	$V_{RX-CM-ACp} = V_{RXD+} + V_{RXD-} /2 - V_{RX-CM-DC}$ $V_{RX-CM-DC} = DC_{(avg)}$ of $ V_{RX-D+} + V_{RX-D-} /2$	—	—	150	mV	2
Differential return loss	$RL_{RX-DIFF}$	Measured over 50 MHz to 1.25 GHz with the D+ and D- lines biased at +300 mV and -300 mV, respectively.	15	—	—	dB	4
Common mode return loss	RL_{RX-CM}	Measured over 50 MHz to 1.25 GHz with the D+ and D- lines biased at 0 V.	6	—	—	dB	4
DC differential input impedance	$Z_{RX-DIFF-DC}$	RX DC differential mode impedance.	80	100	120	Ω	5
DC Input Impedance	Z_{RX-DC}	Required RX D+ as well as D- DC Impedance (50 \pm 20% tolerance).	40	50	60	Ω	2, 5

Table 55. Differential Receiver (RX) Input Specifications (continued)

Parameter	Symbol	Comments	Min	Typical	Max	Unit	Note
Powered down DC input impedance	$Z_{RX-HIGH-IMP-DC}$	Required RX D+ as well as D- DC Impedance when the Receiver terminations do not have power.	200 k	—	—	Ω	6
Electrical idle detect threshold	$V_{RX-IDLE-DET-DIFFp-p}$	$V_{PEEIDT} = 2 * V_{RX-D+} - V_{RX-D-} $ Measured at the package pins of the Receiver	65	—	175	mV	—
Unexpected Electrical Idle Enter Detect Threshold Integration Time	$T_{RX-IDLE-DET-DIFF-ENTERTIME}$	An unexpected Electrical Idle ($V_{rx-diff-p} < V_{rx-idle-det-diff-p}$) must be recognized no longer than $T_{rx-idle-det-diff-entertime}$ to signal an unexpected idle condition.	—	—	10	ms	—
Total Skew	$L_{RX-SKEW}$	Skew across all lanes on a Link. This includes variation in the length of SKP ordered set (e.g. COM and one to five SKP Symbols) at the RX as well as any delay differences arising from the interconnect itself.	—	—	20	ns	—

Note:

1. No test load is necessarily associated with this value.
2. Specified at the measurement point and measured over any 250 consecutive UIs. The test load in [Figure 51](#) should be used as the RX device when taking measurements (also refer to the receiver compliance eye diagram shown in [Figure 50](#)). If the clocks to the RX and TX are not derived from the same reference clock, the TX UI recovered from 3500 consecutive UI must be used as a reference for the eye diagram.
3. A $T_{RX-EYE} = 0.40$ UI provides for a total sum of 0.60 UI deterministic and random jitter budget for the transmitter and interconnect collected any 250 consecutive UIs. The $T_{RX-EYE-MEDIAN-to-MAX-JITTER}$ specification ensures a jitter distribution in which the median and the maximum deviation from the median is less than half of the total. UI jitter budget collected over any 250 consecutive TX UIs. It should be noted that the median is not the same as the mean. The jitter median describes the point in time where the number of jitter points on either side is approximately equal as opposed to the averaged time value. If the clocks to the RX and TX are not derived from the same reference clock, the TX UI recovered from 3500 consecutive UI must be used as the reference for the eye diagram.
4. The receiver input impedance shall result in a differential return loss greater than or equal to 15 dB with the D+ line biased to 300 mV and the D- line biased to -300 mV and a common mode return loss greater than or equal to 6 dB (no bias required) over a frequency range of 50 MHz to 1.25 GHz. This input impedance requirement applies to all valid input levels. The reference impedance for return loss measurements for is 50 Ω to ground for both the D+ and D- line (that is, as measured by a vector network analyzer with 50- Ω probes, see [Figure 51](#)). Note that the series capacitors, C_{TX} , is optional for the return loss measurement.
5. Impedance during all LTSSM states. When transitioning from a fundamental reset to detect (the initial state of the LTSSM) there is a 5 ms transition time before receiver termination values must be met on all unconfigured lanes of a port.
6. The RX DC common mode impedance that exists when no power is present or fundamental reset is asserted. This helps ensure that the receiver detect circuit does not falsely assume a receiver is powered on when it is not. This term must be measured at 300 mV above the RX ground.
7. It is recommended that the recovered TX UI is calculated using all edges in the 3500 consecutive UI interval with a fit algorithm using a minimization merit function. Least squares and median deviation fits have worked well with experimental and simulated data.

16.5 Receiver Compliance Eye Diagrams

The RX eye diagram in [Figure 50](#) is specified using the passive compliance/test measurement load (see [Figure 51](#)) in place of any real PCI Express RX component. In general, the minimum receiver eye diagram measured with the compliance/test measurement load (see [Figure 51](#)) is larger than the minimum receiver eye diagram measured over a range of systems at the input receiver of any real PCI Express component. The degraded eye diagram at the input Receiver is due to traces internal to the package as well as silicon parasitic characteristics which cause the real PCI Express component to vary in impedance from the compliance/test measurement load. The input receiver eye diagram is implementation specific and is not specified. RX component designer should provide additional margin to adequately compensate for the degraded minimum Receiver eye diagram (shown in [Figure 50](#)) expected at the input receiver based on an adequate combination of system simulations and the return loss measured looking into the RX package and silicon. The RX eye diagram must be aligned in time using the jitter median to locate the center of the eye diagram.

The eye diagram must be valid for any 250 consecutive UIs.

A recovered TX UI is calculated over 3500 consecutive unit intervals of sample data. The eye diagram is created using all edges of the 250 consecutive UI in the center of the 3500 UI used for calculating the TX UI.

NOTE

The reference impedance for return loss measurements is 50 Ω to ground for both the D+ and D- line (that is, as measured by a Vector Network Analyzer with 50 Ω probes—see [Figure 51](#)). Note that the series capacitors, $C_{PEACCTX}$, are optional for the return loss measurement.

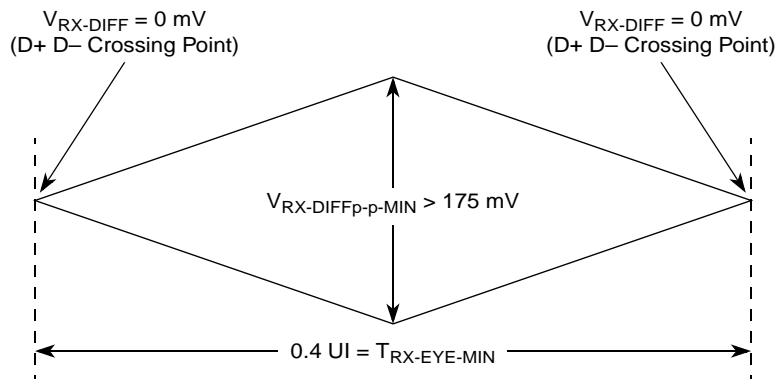

Figure 50. Minimum Receiver Eye Timing and Voltage Compliance Specification

16.5.1 Compliance Test and Measurement Load

The AC timing and voltage parameters must be verified at the measurement point, as specified within 0.2 inches of the package pins, into a test/measurement load shown in [Figure 51](#).

NOTE

The allowance of the measurement point to be within 0.2 inches of the package pins is meant to acknowledge that package/board routing may benefit from D+ and D– not being exactly matched in length at the package pin boundary.

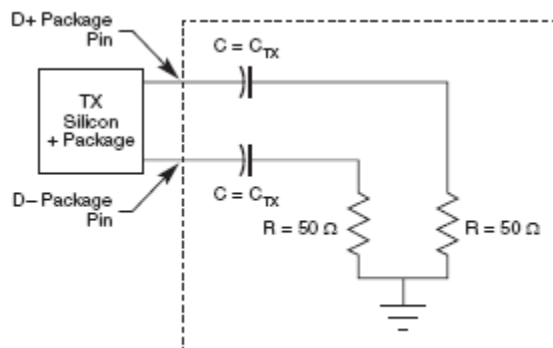

Figure 51. Compliance Test/Measurement Load

17 Timers

This section describes the DC and AC electrical specifications for the timers of the MPC8314E.

17.1 Timers DC Electrical Characteristics

This table provides the DC electrical characteristics for the timers pins, including T_{IN} , $\overline{T_{OUT}}$, $\overline{T_{GATE}}$, and RTC_CLK .

Table 56. Timers DC Electrical Characteristics

Characteristic	Symbol	Condition	Min	Max	Unit
Output high voltage	V_{OH}	$I_{OH} = -8.0 \text{ mA}$	2.4	—	V
Output low voltage	V_{OL}	$I_{OL} = 8.0 \text{ mA}$	—	0.5	V
Output low voltage	V_{OL}	$I_{OL} = 3.2 \text{ mA}$	—	0.4	V
Input high voltage	V_{IH}	—	2.1	$NVDD + 0.3$	V
Input low voltage	V_{IL}	—	-0.3	0.8	V
Input current	I_{IN}	$0 \text{ V} \leq V_{IN} \leq NVDD$	—	± 5	μA

17.2 Timers AC Timing Specifications

This table provides the timers input and output AC timing specifications.

Table 57. Timers Input AC Timing Specifications

Characteristic	Symbol ¹	Min	Unit
Timers inputs—minimum pulse width	t_{TIWID}	20	ns

Table 57. Timers Input AC Timing Specifications

Characteristic	Symbol ¹	Min	Unit
----------------	---------------------	-----	------

Note:

- Timers inputs and outputs are asynchronous to any visible clock. Timers outputs should be synchronized before use by any external synchronous logic. Timers input are required to be valid for at least t_{PIWID} ns to ensure proper operation.

This figure provides the AC test load for the Timers.

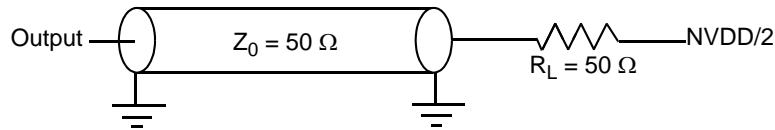

Figure 52. Timers AC Test Load

18 GPIO

This section describes the DC and AC electrical specifications for the GPIO of the MPC8314E.

18.1 GPIO DC Electrical Characteristics

This table provides the DC electrical characteristics for the GPIO.

Table 58. GPIO DC Electrical Characteristics

Characteristic	Symbol	Condition	Min	Max	Unit
Output high voltage	V_{OH}	$I_{OH} = -8.0$ mA	2.4	—	V
Output low voltage	V_{OL}	$I_{OL} = 8.0$ mA	—	0.5	V
Output low voltage	V_{OL}	$I_{OL} = 3.2$ mA	—	0.4	V
Input high voltage	V_{IH}	—	2.1	$NVDD + 0.3$	V
Input low voltage	V_{IL}	—	-0.3	0.8	V
Input current	I_{IN}	$0\text{ V} \leq V_{IN} \leq NVDD$	—	± 5	μA

18.2 GPIO AC Timing Specifications

This table provides the GPIO input and output AC timing specifications.

Table 59. GPIO Input AC Timing Specifications

Characteristic	Symbol ¹	Min	Unit
GPIO inputs—minimum pulse width	t_{PIWID}	20	ns

Note:

- GPIO inputs and outputs are asynchronous to any visible clock. GPIO outputs should be synchronized before use by any external synchronous logic. GPIO inputs are required to be valid for at least t_{PIWID} ns to ensure proper operation.

This figure provides the AC test load for the GPIO.

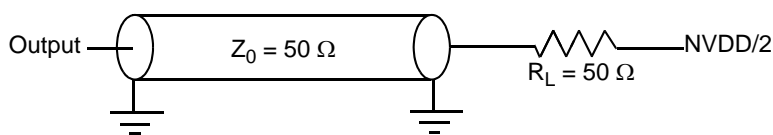

Figure 53. GPIO AC Test Load

19 IPIC

This section describes the DC and AC electrical specifications for the external interrupt pins of the MPC8314E.

19.1 IPIC DC Electrical Characteristics

This table provides the DC electrical characteristics for the external interrupt pins.

Table 60. IPIC DC Electrical Characteristics

Characteristic	Symbol	Condition	Min	Max	Unit
Input high voltage	V_{IH}	—	2.1	NVDD + 0.3	V
Input low voltage	V_{IL}	—	-0.3	0.8	V
Input current	I_{IN}	—	—	±5	μA
Output high voltage	V_{OH}	$I_{OH} = -8.0$ mA	2.4	—	V
Output low voltage	V_{OL}	$I_{OL} = 8.0$ mA	—	0.5	V
Output low voltage	V_{OL}	$I_{OL} = 3.2$ mA	—	0.4	V

19.2 IPIC AC Timing Specifications

This table provides the IPIC input and output AC timing specifications.

Table 61. IPIC Input AC Timing Specifications

Characteristic	Symbol ¹	Min	Unit
IPIC inputs—minimum pulse width	t_{PIWID}	20	ns

Note:

1. IPIC inputs and outputs are asynchronous to any visible clock. IPIC outputs should be synchronized before use by any external synchronous logic. IPIC inputs are required to be valid for at least t_{PIWID} ns to ensure proper operation when working in edge triggered mode.

20 SPI

This section describes the DC and AC electrical specifications for the SPI of the MPC8314E.

20.1 SPI DC Electrical Characteristics

This table provides the DC electrical characteristics for the SPI.

Table 62. SPI DC Electrical Characteristics

Characteristic	Symbol	Condition	Min	Max	Unit
Input high voltage	V_{IH}	—	2.1	NVDD + 0.3	V
Input low voltage	V_{IL}	—	-0.3	0.8	V
Input current	I_{IN}	—	—	±5	μA
Output high voltage	V_{OH}	$I_{OH} = -8.0$ mA	2.4	—	V
Output low voltage	V_{OL}	$I_{OL} = 8.0$ mA	—	0.5	V
Output low voltage	V_{OL}	$I_{OL} = 3.2$ mA	—	0.4	V

20.2 SPI AC Timing Specifications

This table and provide the SPI input and output AC timing specifications.

Table 63. SPI AC Timing Specifications ¹

Characteristic	Symbol ²	Min	Max	Unit
SPI outputs valid—master mode (internal clock) delay	t_{NIKHOV}	—	6	ns
SPI outputs hold—master mode (internal clock) delay	t_{NIKHOX}	0.5	—	ns
SPI outputs valid—slave mode (external clock) delay	t_{NEKHOV}	—	8.5	ns
SPI outputs hold—slave mode (external clock) delay	t_{NEKHOX}	2	—	ns
SPI inputs—master mode (internal clock) input setup time	t_{NIIVKH}	6	—	ns
SPI inputs—master mode (internal clock)input hold time	t_{NIIXKH}	0	—	ns
SPI inputs—slave mode (external clock) input setup time	t_{NEIVKH}	4	—	ns
SPI inputs—slave mode (external clock) input hold time	t_{NEIXKH}	2	—	ns

Note:

1. Output specifications are measured from the 50% level of the rising edge of SPICLK to the 50% level of the signal. Timings are measured at the pin.
2. The symbols used for timing specifications follow the pattern of $t_{(\text{first two letters of functional block})(\text{signal})(\text{state})(\text{reference})(\text{state})}$ for inputs and $t_{(\text{first two letters of functional block})(\text{reference})(\text{state})(\text{signal})(\text{state})}$ for outputs. For example, t_{NIKHOX} symbolizes the internal timing (NI) for the time SPICLK clock reference (K) goes to the high state (H) until outputs (O) are invalid (X).

This figure provides the AC test load for the SPI.

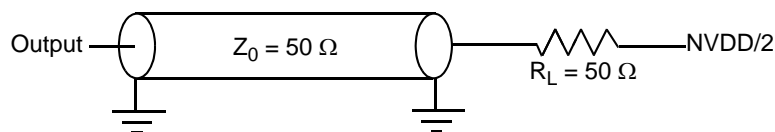
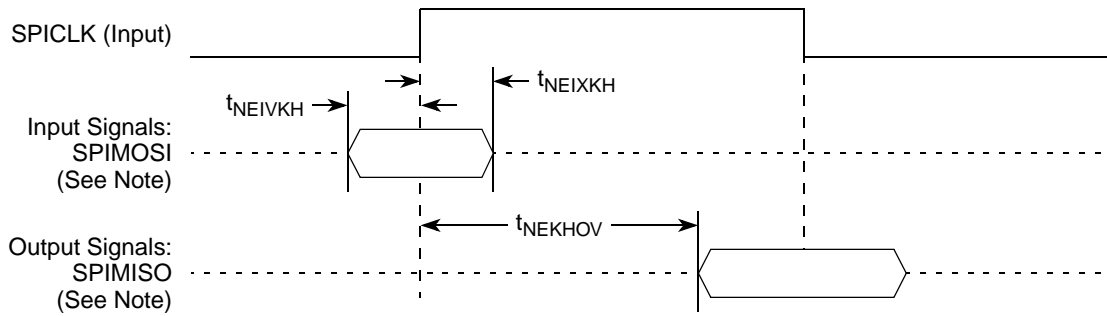

Figure 54. SPI AC Test Load

Figure 55 and Figure 56 represent the AC timing from Table 63. Note that although the specifications generally reference the rising edge of the clock, these AC timing diagrams also apply when the falling edge is the active edge.

This figure shows the SPI timing in slave mode (external clock).



Note: The clock edge is selectable on SPI.

Figure 55. SPI AC Timing in Slave Mode (External Clock) Diagram

This figure shows the SPI timing in master mode (internal clock).

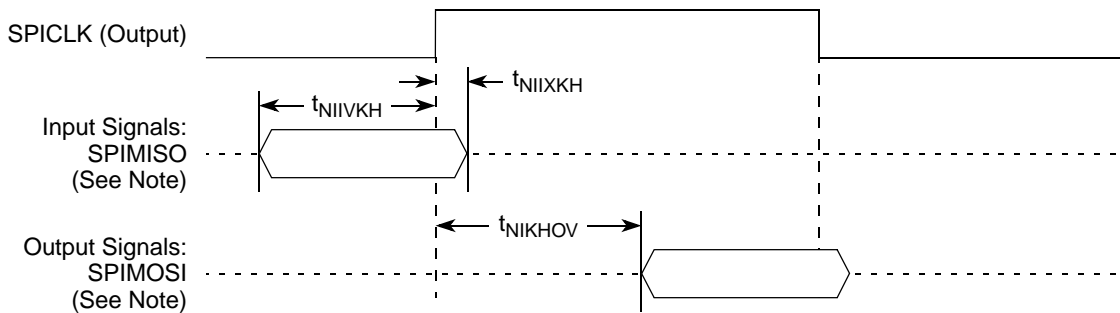

Note: The clock edge is selectable on SPI.

Figure 56. SPI AC Timing in Master Mode (Internal Clock) Diagram

21 TDM

This section describes the DC and AC electrical specifications for the TDM of the MPC8314E.

21.1 TDM DC Electrical Characteristics

This table provides the DC electrical characteristics TDM.

Table 64. TDM DC Electrical Characteristics

Characteristic	Symbol	Condition	Min	Max	Unit
Output high voltage	V_{OH}	$I_{OH} = -8.0 \text{ mA}$	2.4	—	V
Output low voltage	V_{OL}	$I_{OL} = 8.0 \text{ mA}$	—	0.5	V
Output low voltage	V_{OL}	$I_{OL} = 3.2 \text{ mA}$	—	0.4	V
Input high voltage	V_{IH}	—	2.1	$NVDD + 0.3$	V
Input low voltage	V_{IL}	—	-0.3	0.8	V
Input current	I_{IN}	$0 \text{ V} \leq V_{IN} \leq NVDD$	—	± 5	μA

21.2 TDM AC Electrical Characteristics

This table provides the TDM AC timing specifications.

Table 65. TDM AC Timing specifications

Parameter/Condition	Symbol	Min	Max	Unit
TDMxRCK/TDMxTCK	t_{DM}	20.0	—	ns
TDMxRCK/TDMxTCK high pulse width	t_{DM_HIGH}	8.0	—	ns
TDMxRCK/TDMxTCK low pulse width	t_{DM_LOW}	8.0	—	ns
TDMxRCK/TDMxTCK rise time (20% to 80%)	t_{DMKH}	1.0	4.0	ns
TDMxRCK/TDMxTCK fall time (80% to 20%)	t_{DMKL}	1.0	4.0	ns
TDM all input setup time	t_{DMIVKH}	3.0	—	ns
TDMxRD hold time	$t_{DMRDIXKH}$	3.5	—	ns
TDMxTFS/TDMxRFS input hold time	$t_{DMFSIXKH}$	2.0	—	ns
TDMxTCK High to TDMxTD output active	t_{DM_OUTAC}	4.0	—	ns
TDMxTCK High to TDMxTD output valid	$t_{DMTKHOV}$	—	14.0	ns
TDMxTD hold time	$t_{DMTKHOX}$	2.0	—	ns
TDMxTCK High to TDMxTD output high impedance	t_{DM_OUTH}	—	10.0	ns
TDMxTFS/TDMxRFS output valid	$t_{DMFSKHOV}$	—	13.5	ns
TDMxTFS/TDMxRFS output hold time	$t_{DMFSKHOX}$	2.5	—	ns

Note:

1. The symbols used for timing specifications herein follow the pattern of $t_{(first\ two\ letters\ of\ functional\ block)(signal)(state)\ (reference)(state)}$ for inputs and $t_{(first\ two\ letters\ of\ functional\ block)(reference)(state)(signal)(state)}$ for outputs. For example, $t_{TDMIVKH}$ symbolizes TDM timing (DM) with respect to the time the input signals (I) reach the valid state (V) relative to the TDM Clock, t_{TC} , reference (K) going to the high (H) state or setup time. Also, output signals (O), hold (X).
2. Output values are based on 30 pF capacitive load.
3. Inputs are referenced to the sampling that the TDM is programmed to use. Outputs are referenced to the programming edge they are programmed to use. Use of the rising edge or falling edge as a reference is programmable. TDMxTCK and TDMxRCK are shown using the rising edge.

This figure shows the TDM receive signal timing.

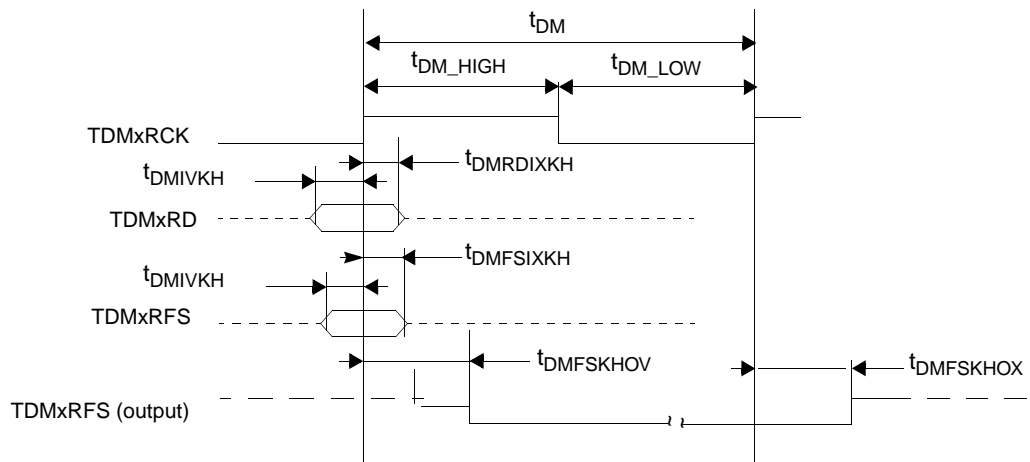

Figure 57. TDM Receive Signals

This figure shows the TDM transmit signal timing.

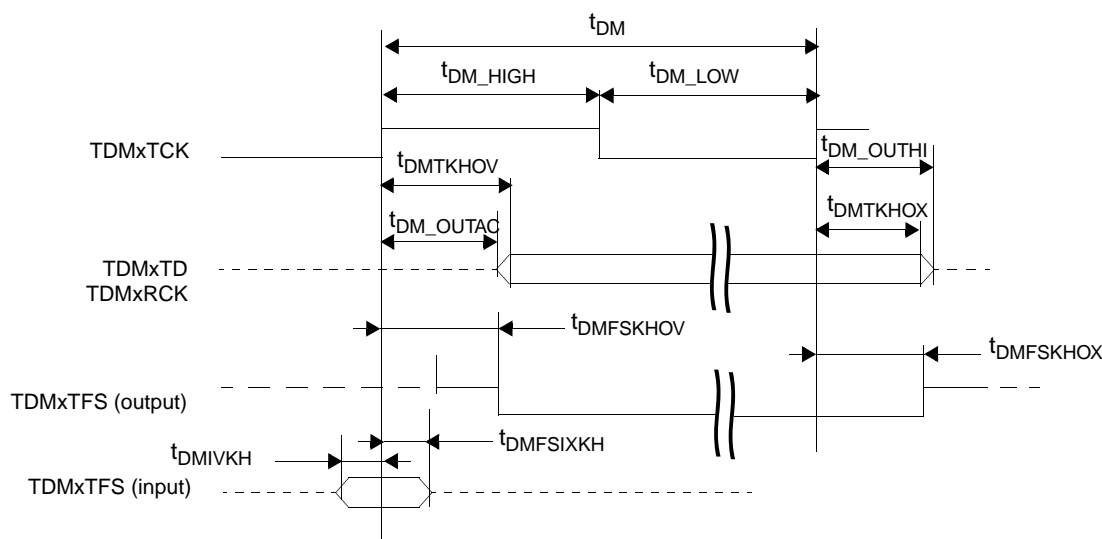

Figure 58. TDM Transmit Signals

22 Package and Pin Listings

This section details package parameters, pin assignments, and dimensions. The MPC8314E is available in a thermally enhanced plastic ball grid array (TEPBGA II), see [Section 22.1, “Package Parameters for the MPC8314E TEPBGA II,”](#) and [Section 22.2, “Mechanical Dimensions of the TEPBGA II,”](#) for information on the TEPBGA II.

22.1 Package Parameters for the MPC8314E TEPBGA II

The package parameters are as provided in the following list. The package type is 29 mm × 29 mm, TEPBGA II.

Package outline	29 mm × 29 mm
Interconnects	620
Pitch	1 mm
Module height (typical)	2.23 mm
Solder balls	96.5 Sn/3.5 Ag (VR package)
Ball diameter (typical)	0.6 mm

22.2 Mechanical Dimensions of the TEPBGA II

This figure shows the mechanical dimensions and bottom surface nomenclature of the 620-pin TEPBGA II package.

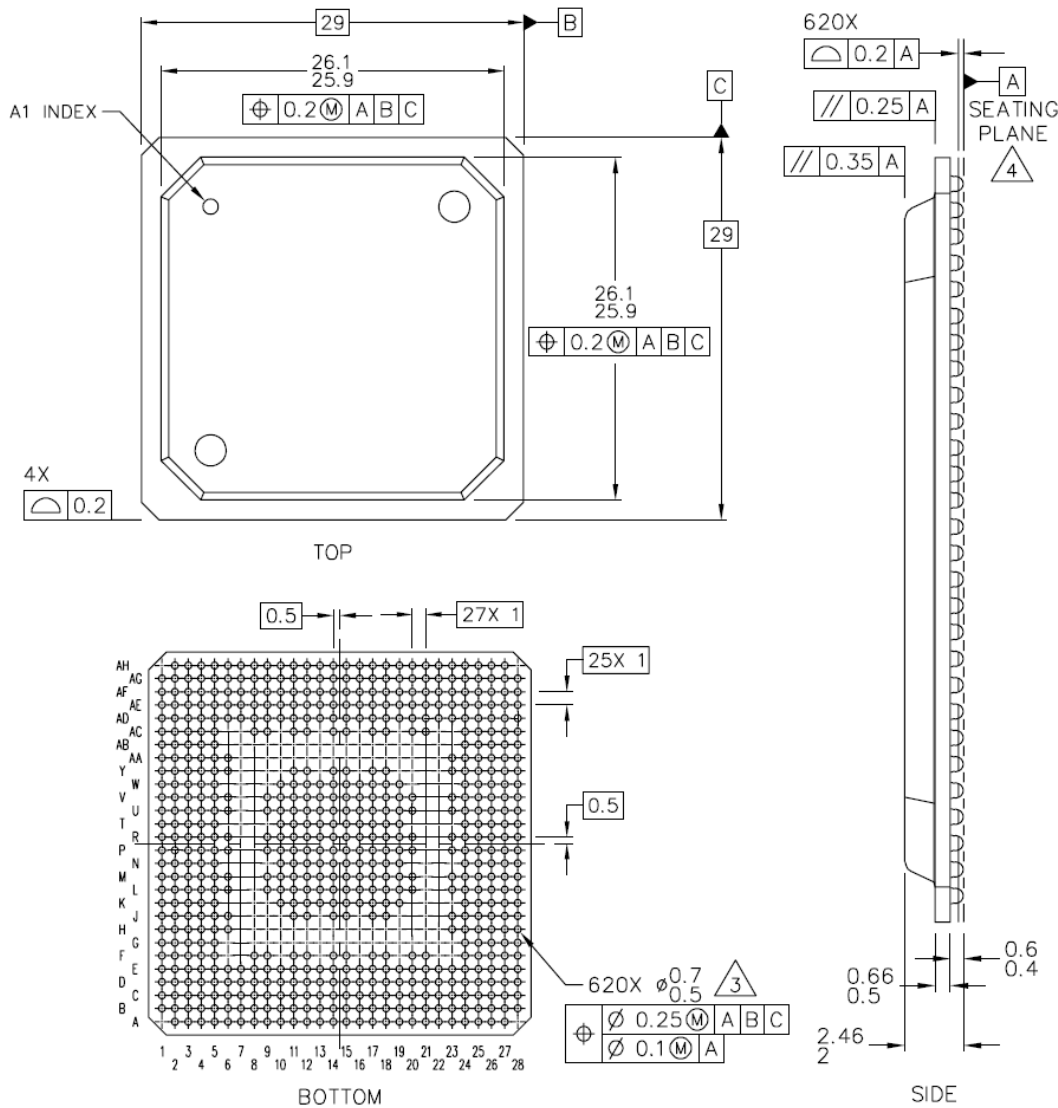

Notes:

1. All dimensions are in millimeters.
2. Dimensions and tolerances per ASME Y14.5M-1994.
3. Maximum solder ball diameter measured parallel to datum A.
4. Datum A, the seating plane, is determined by the spherical crowns of the solder balls.

Figure 59. Mechanical Dimensions and Bottom Surface Nomenclature of the TEPBGA II

22.3 Pinout Listings

This table provides the pin-out listing for the TEPBGA II package.

Table 66. MPC8314E TEPBGA II Pinout Listing

Signal	Package Pin Number	Pin Type	Power Supply	Note
DDR Memory Controller Interface				
MEMC_MDQ[0]	AF16	I/O	GVDD	—
MEMC_MDQ[1]	AE17	I/O	GVDD	—
MEMC_MDQ[2]	AH17	I/O	GVDD	—
MEMC_MDQ[3]	AG17	I/O	GVDD	—
MEMC_MDQ[4]	AG18	I/O	GVDD	—
MEMC_MDQ[5]	AH18	I/O	GVDD	—
MEMC_MDQ[6]	AD18	I/O	GVDD	—
MEMC_MDQ[7]	AF19	I/O	GVDD	—
MEMC_MDQ[8]	AH19	I/O	GVDD	—
MEMC_MDQ[9]	AD19	I/O	GVDD	—
MEMC_MDQ[10]	AG20	I/O	GVDD	—
MEMC_MDQ[11]	AH20	I/O	GVDD	—
MEMC_MDQ[12]	AH21	I/O	GVDD	—
MEMC_MDQ[13]	AE21	I/O	GVDD	—
MEMC_MDQ[14]	AH22	I/O	GVDD	—
MEMC_MDQ[15]	AD21	I/O	GVDD	—
MEMC_MDQ[16]	AG10	I/O	GVDD	—
MEMC_MDQ[17]	AH9	I/O	GVDD	—
MEMC_MDQ[18]	AH8	I/O	GVDD	—
MEMC_MDQ[19]	AD11	I/O	GVDD	—
MEMC_MDQ[20]	AH7	I/O	GVDD	—
MEMC_MDQ[21]	AG7	I/O	GVDD	—
MEMC_MDQ[22]	AF8	I/O	GVDD	—
MEMC_MDQ[23]	AD10	I/O	GVDD	—
MEMC_MDQ[24]	AE9	I/O	GVDD	—
MEMC_MDQ[25]	AH6	I/O	GVDD	—
MEMC_MDQ[26]	AH5	I/O	GVDD	—
MEMC_MDQ[27]	AG6	I/O	GVDD	—
MEMC_MDQ[28]	AH4	I/O	GVDD	—
MEMC_MDQ[29]	AE6	I/O	GVDD	—
MEMC_MDQ[30]	AD8	I/O	GVDD	—
MEMC_MDQ[31]	AF5	I/O	GVDD	—
MEMC_MDM0	AE18	O	GVDD	—
MEMC_MDM1	AE20	O	GVDD	—
MEMC_MDM2	AE10	O	GVDD	—

Table 66. MPC8314E TEPBGA II Pinout Listing (continued)

Signal	Package Pin Number	Pin Type	Power Supply	Note
MEMC_MDM3	AF6	O	GVDD	—
MEMC_MDQS[0]	AF17	I/O	GVDD	—
MEMC_MDQS[1]	AG21	I/O	GVDD	—
MEMC_MDQS[2]	AG9	I/O	GVDD	—
MEMC_MDQS[3]	AF7	I/O	GVDD	—
MEMC_MBA[0]	AH16	O	GVDD	—
MEMC_MBA[1]	AH15	O	GVDD	—
MEMC_MBA[2]	AG15	O	GVDD	—
MEMC_MA0	AD15	O	GVDD	—
MEMC_MA1	AE15	O	GVDD	—
MEMC_MA2	AH14	O	GVDD	—
MEMC_MA3	AG14	O	GVDD	—
MEMC_MA4	AF14	O	GVDD	—
MEMC_MA5	AE14	O	GVDD	—
MEMC_MA6	AH13	O	GVDD	—
MEMC_MA7	AH12	O	GVDD	—
MEMC_MA8	AF13	O	GVDD	—
MEMC_MA9	AD13	O	GVDD	—
MEMC_MA10	AG12	O	GVDD	—
MEMC_MA11	AH11	O	GVDD	—
MEMC_MA12	AH10	O	GVDD	—
MEMC_MA13	AE12	O	GVDD	—
MEMC_MA14	AF11	O	GVDD	—
MEMC_MWE	AE5	O	GVDD	—
MEMC_MRAS	AD7	O	GVDD	—
MEMC_MCAS	AG4	O	GVDD	—
MEMC_MCS[0]	AH3	O	GVDD	—
MEMC_MCS[1]	AD5	O	GVDD	—
MEMC_MCKE	AE4	O	GVDD	3
MEMC_MCK[0]	AF4	O	GVDD	—
MEMC_MCK[0]	AF3	O	GVDD	—
MEMC_MCK[1]	AF1	O	GVDD	—
MEMC_MCK[1]	AE1	O	GVDD	—
MEMC_MODT[0]	AE3	O	GVDD	—
MEMC_MODT[1]	AD4	O	GVDD	—
MEMC_MVREF	AD12	I	GVDD	—

Table 66. MPC8314E TEPBGA II Pinout Listing (continued)

Signal	Package Pin Number	Pin Type	Power Supply	Note
Local Bus Controller Interface				
LAD0	AB28	I/O	NVDD3_OFF	10
LAD1	AB27	I/O	NVDD3_OFF	10
LAD2	AC28	I/O	NVDD3_OFF	10
LAD3	AA24	I/O	NVDD3_OFF	10
LAD4	AC27	I/O	NVDD3_OFF	10
LAD5	AD28	I/O	NVDD3_OFF	10
LAD6	AB25	I/O	NVDD3_OFF	10
LAD7	AC26	I/O	NVDD3_OFF	10
LAD8	AD27	I/O	NVDD3_OFF	10
LAD9	AB24	I/O	NVDD3_OFF	10
LAD10	AE28	I/O	NVDD3_OFF	10
LAD11	AE27	I/O	NVDD3_OFF	10
LAD12	AE26	I/O	NVDD3_OFF	10
LAD13	AF28	I/O	NVDD3_OFF	10
LAD14	AC24	I/O	NVDD3_OFF	10
LAD15	AD25	I/O	NVDD3_OFF	10
LA16	V24	O	NVDD3_OFF	10
LA17	V25	O	NVDD3_OFF	10
LA18	W26	O	NVDD3_OFF	10
LA19	W28	O	NVDD3_OFF	10
LA20	U24	O	NVDD3_OFF	10
LA21	W24	O	NVDD3_OFF	10
LA22	Y28	O	NVDD3_OFF	10
LA23	AH23	O	NVDD3_OFF	10
LA24	AH24	O	NVDD3_OFF	10
LA25	AG23	O	NVDD3_OFF	10
$\overline{\text{LCS}}[0]$	AD22	O	NVDD3_OFF	11
$\overline{\text{LCS}}[1]$	AF25	O	NVDD3_OFF	11
$\overline{\text{LCS}}[2]$	AG24	O	NVDD3_OFF	11
$\overline{\text{LCS}}[3]$	AF24	O	NVDD3_OFF	11
$\overline{\text{LWE}}[0] / \overline{\text{LFW}} / \overline{\text{LBS}}$	AE23	O	NVDD3_OFF	11
$\overline{\text{LWE}}[1]$	AG26	O	NVDD3_OFF	11
LBCTL	AH26	O	NVDD3_OFF	11
LALE	AF26	O	NVDD3_OFF	10
LGPL0/LFCLE	Y27	O	NVDD3_OFF	—

Table 66. MPC8314E TEPBGA II Pinout Listing (continued)

Signal	Package Pin Number	Pin Type	Power Supply	Note
LGPL1/LFALE	AA28	O	NVDD3_OFF	—
LGPL2/LFRE/LOE	Y25	O	NVDD3_OFF	11
LGPL3/LFWP	Y24	O	NVDD3_OFF	—
LGPL4/LGTÀ/LUPWAIT/LFRB	AA26	I/O	NVDD3_OFF	2
LGPL5	AF22	O	NVDD3_OFF	11
LCLK0	AH25	O	NVDD3_OFF	10
LCLK1	AD24	O	NVDD3_OFF	10
DUART				
UART_SOUT1/MSRCID0 (DDR ID)/LSRCID0	C15	O	NVDD2_OFF	—
UART_SIN1/MSRCID1 (DDR ID)/LSRCID1	B16	I/O	NVDD2_OFF	—
UART_CTS[1]/MSRCID2 (DDR ID)/LSRCID2	D16	I/O	NVDD2_OFF	—
UART_RTS[1]/MSRCID3 (DDR ID)/LSRCID3	B17	O	NVDD2_OFF	—
UART_SOUT2/MSRCID4 (DDR ID)/LSRCID4	A16	O	NVDD2_OFF	—
UART_SIN2/MDVAL (DDR ID)/LDVAL	C16	I/O	NVDD2_OFF	—
UART_CTS[2]	A17	I	NVDD2_OFF	—
UART_RTS[2]	A18	O	NVDD2_OFF	—
I²C interface				
IIC_SDA/CKSTOP_OUT	N1	I/O	NVDD4_OFF	2
IIC_SCL/CKSTOP_IN	N2	I/O	NVDD4_OFF	2
Interrupts				
MCP_OUT	W1	O	NVDD1_OFF	2
IRQ[0]/MCP_IN	Y3	I	NVDD1_OFF	—
IRQ[1]	E1	I	NVDD1_ON	—
IRQ[2]	A7	I	NVDD1_ON	—
IRQ[3]	AA1	I	NVDD1_OFF	—
IRQ[4]	Y5	I	NVDD1_OFF	—
IRQ[5]/CORE_SRESET_IN	AA2	I	NVDD1_OFF	—
IRQ[6]/CKSTOP_OUT	AA4	I/O	NVDD1_OFF	—
IRQ[7]/CKSTOP_IN	AA5	I	NVDD1_OFF	—
Configuration				
CFG_CLKIN_DIV	A5	I	NVDD1_ON	11
EXT_PWR_CTRL	D3	O	NVDD1_ON	11
PMC_PWR_OK	D4	I	—	11

Table 66. MPC8314E TEPBGA II Pinout Listing (continued)

Signal	Package Pin Number	Pin Type	Power Supply	Note
JTAG				
TCK	E5	I	NVDD1_ON	—
TDI	B4	I	NVDD1_ON	4
TDO	C4	O	NVDD1_ON	3
TMS	C3	I	NVDD1_ON	4
$\overline{\text{TRST}}$	C2	I	NVDD1_ON	4
TDM				
GPIO_18/TDM_RCK	AB1	I/O	NVDD1_OFF	—
GPIO_20/TDM_RD	AC1	I/O	NVDD1_OFF	—
GPIO_19/TDM_RFS	AB3	I/O	NVDD1_OFF	—
GPIO_21/TDM_TCK	AB5	I/O	NVDD1_OFF	—
GPIO_23/TDM_TD	AC3	I/O	NVDD1_OFF	—
GPIO_22/TDM_TFS	AC2	I/O	NVDD1_OFF	—
TEST				
TEST_MODE	D6	I	NVDD1_ON	6
DEBUG				
$\overline{\text{QUIESCE}}$	B5	O	NVDD1_ON	—
System Control				
$\overline{\text{HRESET}}$	B6	I/O	NVDD1_ON	1
$\overline{\text{PORESET}}$	A6	I	NVDD1_ON	—
Clocks				
SYS_XTAL_IN	L27	I	NVDD2_ON	—
SYS_XTAL_OUT	J28	O	NVDD2_ON	—
SYS_CLK_IN	K28	I	NVDD2_ON	—
USB_XTAL_IN	A15	I	NVDD2_OFF	—
USB_XTAL_OUT	B14	O	NVDD2_OFF	—
USB_CLK_IN	B15	I	NVDD2_OFF	—
PCI_SYNC_OUT	J27	O	NVDD2_ON	3
RTC_CLK	K26	I	NVDD2_ON	—
PCI_SYNC_IN	K27	I	NVDD2_ON	—
MISC				
AVDD1	AC15	I	—	—
AVDD2	M23	I	—	—
THERM0	L25	I	NVDD2_ON	7
$\overline{\text{DMA_DACK0}}$ /GPIO_13	AC4	I/O	NVDD1_OFF	—

Table 66. MPC8314E TEPBGA II Pinout Listing (continued)

Signal	Package Pin Number	Pin Type	Power Supply	Note
DMA_DREQ0/GPIO_12	AD1	I/O	NVDD1_OFF	—
DMA_DONE0/GPIO_14	AD2	I/O	NVDD1_OFF	—
NC, No Connect	A2	—	—	—
NC, No Connect	M25	—	—	—
NC, No Connect	P26	—	—	—
NC, No Connect	N25	—	—	—
NC, No Connect	U26	—	—	—
NC, No Connect	T25	—	—	—
NC, No Connect	R26	—	—	—
NC, No Connect	U25	—	—	—
PCI				
PCI_INTA	B18	O	NVDD2_OFF	—
PCI_RESET_OUT	A20	O	NVDD2_OFF	—
PCI_AD[0]	J25	I/O	NVDD2_OFF	—
PCI_AD[1]	J24	I/O	NVDD2_OFF	—
PCI_AD[2]	K24	I/O	NVDD2_OFF	—
PCI_AD[3]	H27	I/O	NVDD2_OFF	—
PCI_AD[4]	H28	I/O	NVDD2_OFF	—
PCI_AD[5]	H26	I/O	NVDD2_OFF	—
PCI_AD[6]	G27	I/O	NVDD2_OFF	—
PCI_AD[7]	G28	I/O	NVDD2_OFF	—
PCI_AD[8]	F26	I/O	NVDD2_OFF	—
PCI_AD[9]	F28	I/O	NVDD2_OFF	—
PCI_AD[10]	G25	I/O	NVDD2_OFF	—
PCI_AD[11]	F27	I/O	NVDD2_OFF	—
PCI_AD[12]	E27	I/O	NVDD2_OFF	—
PCI_AD[13]	E28	I/O	NVDD2_OFF	—
PCI_AD[14]	D28	I/O	NVDD2_OFF	—
PCI_AD[15]	D27	I/O	NVDD2_OFF	—
PCI_AD[16]	B25	I/O	NVDD2_OFF	—
PCI_AD[17]	D24	I/O	NVDD2_OFF	—
PCI_AD[18]	B26	I/O	NVDD2_OFF	—
PCI_AD[19]	C24	I/O	NVDD2_OFF	—
PCI_AD[20]	A26	I/O	NVDD2_OFF	—
PCI_AD[21]	E20	I/O	NVDD2_OFF	—
PCI_AD[22]	A23	I/O	NVDD2_OFF	—

Table 66. MPC8314E TEPBGA II Pinout Listing (continued)

Signal	Package Pin Number	Pin Type	Power Supply	Note
PCI_AD[23]	C22	I/O	NVDD2_OFF	—
PCI_AD[24]	E19	I/O	NVDD2_OFF	—
PCI_AD[25]	A22	I/O	NVDD2_OFF	—
PCI_AD[26]	C20	I/O	NVDD2_OFF	—
PCI_AD[27]	B21	I/O	NVDD2_OFF	—
PCI_AD[28]	D19	I/O	NVDD2_OFF	—
PCI_AD[29]	A19	I/O	NVDD2_OFF	—
PCI_AD[30]	A21	I/O	NVDD2_OFF	—
PCI_AD[31]	B19	I/O	NVDD2_OFF	—
PCI_C/ $\overline{\text{BE}}$ [0]	H24	I/O	NVDD2_OFF	—
PCI_C/ $\overline{\text{BE}}$ [1]	C27	I/O	NVDD2_OFF	—
PCI_C/ $\overline{\text{BE}}$ [2]	A25	I/O	NVDD2_OFF	—
PCI_C/ $\overline{\text{BE}}$ [3]	E21	I/O	NVDD2_OFF	—
PCI_PAR	G24	I/O	NVDD2_OFF	—
$\overline{\text{PCI_FRAME}}$	C28	I/O	NVDD2_OFF	5
$\overline{\text{PCI_TRDY}}$	A24	I/O	NVDD2_OFF	5
$\overline{\text{PCI_IRDY}}$	D25	I/O	NVDD2_OFF	5
$\overline{\text{PCI_STOP}}$	D23	I/O	NVDD2_OFF	5
$\overline{\text{PCI_DEVSEL}}$	E22	I/O	NVDD2_OFF	5
PCI_IDSEL	D26	I	NVDD2_OFF	—
$\overline{\text{PCI_SERR}}$	C25	I/O	NVDD2_OFF	5
$\overline{\text{PCI_PERR}}$	D21	I/O	NVDD2_OFF	5
$\overline{\text{PCI_REQ0}}$	E18	I/O	NVDD2_OFF	—
$\overline{\text{PCI_REQ1/CPCI_HS_ES}}$	C18	I	NVDD2_OFF	—
$\overline{\text{PCI_REQ2}}$	E17	I	NVDD2_OFF	—
$\overline{\text{PCI_GNT0}}$	B20	I/O	NVDD2_OFF	—
$\overline{\text{PCI_GNT1/CPCI_HS_LED}}$	D17	O	NVDD2_OFF	—
$\overline{\text{PCI_GNT2/CPCI_HS_ENUM}}$	E15	O	NVDD2_OFF	—
M66EN	L24	I	NVDD2_OFF	—
PCI_CLK0	E23	O	NVDD2_OFF	—
PCI_CLK1	F24	O	NVDD2_OFF	—
PCI_CLK2	E25	O	NVDD2_OFF	—
$\overline{\text{PCI_PME}}$	B23	I/O	NVDD2_OFF	2
ETSEC1/_USBULPI				
GPIO_24/TSEC1_COL/USBDR_TXDRXD0	J1	I/O	LVDD1_OFF	—
GPIO_25/TSEC1_CRS/USBDR_TXDRXD1	H1	I/O	LVDD1_OFF	—

Table 66. MPC8314E TEPBGA II Pinout Listing (continued)

Signal	Package Pin Number	Pin Type	Power Supply	Note
TSEC1_GTX_CLK/USBDR_TXDRXD2	K5	I/O	LVDD1_OFF	3
TSEC1_RX_CLK/USBDR_TXDRXD3	J4	I/O	LVDD1_OFF	—
TSEC1_RX_DV/USBDR_TXDRXD4	J2	I/O	LVDD1_OFF	—
TSEC1_RXD[3]/USBDR_TXDRXD5	G1	I/O	LVDD1_OFF	—
TSEC1_RXD[2]/USBDR_TXDRXD6	H3	I/O	LVDD1_OFF	—
TSEC1_RXD[1]/USBDR_TXDRXD7/TSEC_TMR_CLK	J5	I/O	LVDD1_OFF	—
TSEC1_RXD[0]/USBDR_NXT/TSEC_TMR_TRIG1	H2	I	LVDD1_OFF	—
TSEC1_RX_ER/USBDR_DIR/TSEC_TMR_TRIG2	H5	I	LVDD1_OFF	—
TSEC1_TX_CLK/USBDR_CLK	G2	I	LVDD1_OFF	—
GPIO_28/TSEC1_TXD[3]/TSEC_TMR_GCLK	F3	I/O	LVDD1_OFF	—
GPIO_29/TSEC1_TXD[2]/TSEC_TMR_PP1	F2	I/O	LVDD1_OFF	—
GPIO_30/TSEC1_TXD[1]/TSEC_TMR_PP2	F1	I/O	LVDD1_OFF	—
TSEC1_TXD[0]/USBDR_STP/TSEC_TMR_PP3	G4	O	LVDD1_OFF	11
GPIO_31/TSEC1_TX_EN/TSEC_TMR_ALARM1	F4	I/O	LVDD1_OFF	—
TSEC1_TX_ER/TSEC_TMR_ALARM2	G5	O	LVDD1_OFF	—
TSEC_GTX_CLK125	D1	I	NVDD1_ON	—
TSEC_MDC/LB_POR_CFG_BOOT_ECC	E3	I/O	NVDD1_ON	9
TSEC_MDIO	E2	I/O	NVDD1_ON	
ETSEC2				
GPIO_26/TSEC2_COL	A8	I/O	LVDD2_ON	—
GPIO_27/TSEC2_CRS	E9	I/O	LVDD2_ON	—
TSEC2_GTX_CLK	B10	O	LVDD2_ON	—
TSEC2_RX_CLK	B8	I	LVDD2_ON	—
TSEC2_RX_DV	C9	I	LVDD2_ON	—
TSEC2_RXD[3]	C10	I	LVDD2_ON	—
TSEC2_RXD[2]	D10	I	LVDD2_ON	—
TSEC2_RXD[1]	A9	I	LVDD2_ON	—
TSEC2_RXD[0]	B9	I	LVDD2_ON	—
TSEC2_RX_ER	A10	I	LVDD2_ON	—
TSEC2_TX_CLK	D8	I	LVDD2_ON	—
TSEC2_TXD[3]/CFG_RESET_SOURCE[0]	D11	I/O	LVDD2_ON	—
TSEC2_TXD[2]/CFG_RESET_SOURCE[1]	C7	I/O	LVDD2_ON	—

Table 66. MPC8314E TEPBGA II Pinout Listing (continued)

Signal	Package Pin Number	Pin Type	Power Supply	Note
TSEC2_TXD[1]/CFG_RESET_SOURCE[2]	E8	I/O	LVDD2_ON	—
TSEC2_TXD[0]/CFG_RESET_SOURCE[3]	B7	I/O	LVDD2_ON	—
TSEC2_TX_EN	D12	O	LVDD2_ON	—
TSEC2_TX_ER	B11	O	LVDD2_ON	—
SGMII / PCI Express PHY				
TXA	P4	O	XPADVDD	—
$\overline{\text{TXA}}$	N4	O	XPADVDD	—
RXA	R1	I	XCOREVDD	—
$\overline{\text{RXA}}$	P1	I	XCOREVDD	—
TXB	U4	O	XPADVDD	—
$\overline{\text{TXB}}$	V4	O	XPADVDD	—
RXB	U1	I	XCOREVDD	—
$\overline{\text{RXB}}$	V1	I	XCOREVDD	—
SD_IMP_CAL_RX	N3	I	XCOREVDD	—
$\overline{\text{SD_REF_CLK}}$	R4	I	XCOREVDD	—
SD_REF_CLK	R5	I	XCOREVDD	—
SD_PLL_TPD	T2	O	—	—
SD_IMP_CAL_TX	V5	I	XPADVDD	—
SDAVDD	T3	I	—	—
SD_PLL_TPA_ANA	T4	O	—	—
SDAVSS	T5	I	—	—
USB Phy				
USB_DP	A11	I/O	USB_VDDA	—
USB_DM	A12	I/O	USB_VDDA	—
USB_VBUS	C12	I	—	—
USB_TPA	A14	O	—	—
USB_RBIAS	D14	I	—	8
USB_PLL_PWR3	A13	I	—	—
USB_PLL_GND0 & USB_PLL_GND1	D13	I	—	—
USB_PLL_PWR1	B13	I	—	—
USB_VSSA_BIAS	E14	I	—	—
USB_VDDA_BIAS	C14	I	—	—
USB_VSSA	E13	I	—	—
USB_VDDA	E12	I	—	—
GPIO				
GPIO_0/DMA_DREQ1/GTM1_TOUT1	C5	I/O	NVDD1_ON	—

Table 66. MPC8314E TEPBGA II Pinout Listing (continued)

Signal	Package Pin Number	Pin Type	Power Supply	Note
GPIO_1/DMA_DACK1/GTM1_TIN2/GTM2_TIN1	A4	I/O	NVDD1_ON	—
GPIO_2/DMA_DONE1/GTM1_TGATE2/GTM2_TGATE1	K3	I/O	NVDD4_OFF	—
GPIO_3/GTM1_TIN3/GTM2_TIN4	K1	I/O	NVDD4_OFF	—
GPIO_4/GTM1_TGATE3/GTM2_TGATE4	K2	I/O	NVDD4_OFF	—
GPIO_5/GTM1_TOUT3/GTM2_TOUT1	L5	I/O	NVDD4_OFF	—
GPIO_6/GTM1_TIN4/GTM2_TIN3	L3	I/O	NVDD4_OFF	—
GPIO_7/GTM1_TGATE4/GTM2_TGATE3	L1	I/O	NVDD4_OFF	—
GPIO_8/USBDR_DRIVE_VBUS/GTM1_TIN1/GTM2_TIN2	M1	I/O	NVDD4_OFF	—
GPIO_9/USBDR_PWRFAULT/GTM1_TGATE1/GTM2_TGATE2	M2	I/O	NVDD4_OFF	—
GPIO_10/USBDR_PCTL0/GTM1_TOUT2/GTM2_TOUT1	M5	I/O	NVDD4_OFF	—
GPIO_11/USBDR_PCTL1/GTM1_TOUT4/GTM2_TOUT3	M4	I/O	NVDD4_OFF	—
SPI				
SPIMOSI/GPIO_15	W3	I/O	NVDD1_OFF	—
SPIMISO/GPIO_16	W4	I/O	NVDD1_OFF	—
SPICK	Y1	I/O	NVDD1_OFF	—
SPISEL/GPIO_17	W2	I/O	NVDD1_OFF	—
Power and Ground Supplies				
GVDD	Y11, Y12, Y14, Y15, Y17, AC8, AC11, AC14, AC17, AD6, AD9, AD17, AE8, AE13, AE19, AF10, AF15, AF21, AG2, AG3, AG8, AG13, AG19, AH2	I	—	—
LVDD1_OFF	H6, J3, L6, L9, M9	I	—	—
LVDD2_ON	C11, D9, E10, F11, J12	I	—	—
NVDD1_OFF	U9, V9, W10, Y4, Y6, AA3, AB4	I	—	—
NVDD1_ON	B1, B2, C1, D5, E7, F5, F9, J11, K10	I	—	—
NVDD2_OFF	B22, B27, C19, E16, F15, F18, F21, F25, H25, J17, J18, J23, L20, M20	I	—	—
NVDD2_ON	L26, N19	I	—	—
NVDD3_OFF	U20, V20, V23, V26, W19, Y18, Y26, AA23, AA25, AC20, AC25, AD23, AE25, AG25, AG27, T27, U27	I	—	—
NVDD4_OFF	K4, L2, M6, N10	I	—	—

Table 66. MPC8314E TEPBGA II Pinout Listing (continued)

Signal	Package Pin Number	Pin Type	Power Supply	Note
VDD	J15, K15, K16, K17, K18, K19, L10, L19, M10, T10, U10, U19, V10, V19, W11, W12, W13, W14, W15, W16, W17, W18, P23, R23, T19, M26, N26, P28, R28, U23, N27	I	—	—
VDDC	J14, K11, K12, K13, K14, M19	I	—	—
VSS	A3, A27, B3, B12, B24, B28, C6, C8, C13, C17, C21, C23, C26, D2, D7, D15, D18, D20, D22, E4, E6, E11, E24, E26, F8, F12, F14, F17, F20, G3, G26, H4, H23, J6, J26, K25, L4, L11, L12, L13, L14, L15, L16, L17, L18, L23, L28, M3, M11, M12, M13, M14, M15, M16, M17, M18, N5, N11, N12, N13, N14, N15, N16, N17, N18, P6, P11, P12, P13, P14, P15, P16, P17, P18, R6, R11, R12, R13, R14, R15, R16, R17, R18, T11, T12, T13, T14, T15, T16, T17, T18, U5, U6, U11, U12, U13, U14, U15, U16, U17, U18, V6, V11, V12, V13, V14, V15, V16, V17, V18, W5, W25, W27, Y2, Y23, AA6, AA27, AB2, AB26, AC5, AC9, AC12, AC18, AC21, AD3, AD14, AD16, AD20, AD26, AE2, AE7, AE11, AE16, AE22, AE24, AF2, AF9, AF12, AF18, AF20, AF23, AF27, AG1, AG5, AG11, AG16, AG22, AG28, AH27, U28, N28, M28, T28, V27, M27, V28, T26, P24, R19, R20, R24, M24, N24, P19, P20, P25, P27, R25, R27, T24	I	—	—
XCOREVDD	P2, P10, R2, T1	I	—	—
XCOREVSS	R3, R10, U2, V2	I	—	—
XPADVDD	P3, R9, U3	I	—	—
XPADVSS	P5, P9, V3	I	—	—

Note:

1. This pin is an open drain signal. A weak pull-up resistor (1 k Ω) should be placed on this pin to NVDD.
2. This pin is an open drain signal. A weak pull-up resistor (2–10 k Ω) should be placed on this pin to NVDD.
3. This output is actively driven during reset rather than being three-stated during reset.
4. These JTAG pins have weak internal pull-up P-FETs that are always enabled.
5. This pin should have a weak pull up if the chip is in PCI host mode. Follow PCI specifications recommendation.
6. This pin must always be tied to VSS.
7. Thermal sensitive resistor.
8. This pin should be connected to USB_VSSA_BIAS through 10K precision resistor.
9. The LB_POR_CFG_BOOT_ECC functionality for this pin is only available in MPC8314E revision 1.1 and later. The LB_POR_CFG_BOOT_ECC is sampled only during the $\overline{\text{PORESET}}$ negation. This pin with an internal pull down resistor enables the ECC by default. To disable the ECC an external strong pull up resistor or a tristate buffer is needed.
10. This pin has a weak internal pull-down.
11. This pin has a weak internal pull-up.

23 Clocking

This figure shows the internal distribution of clocks within the MPC8314E

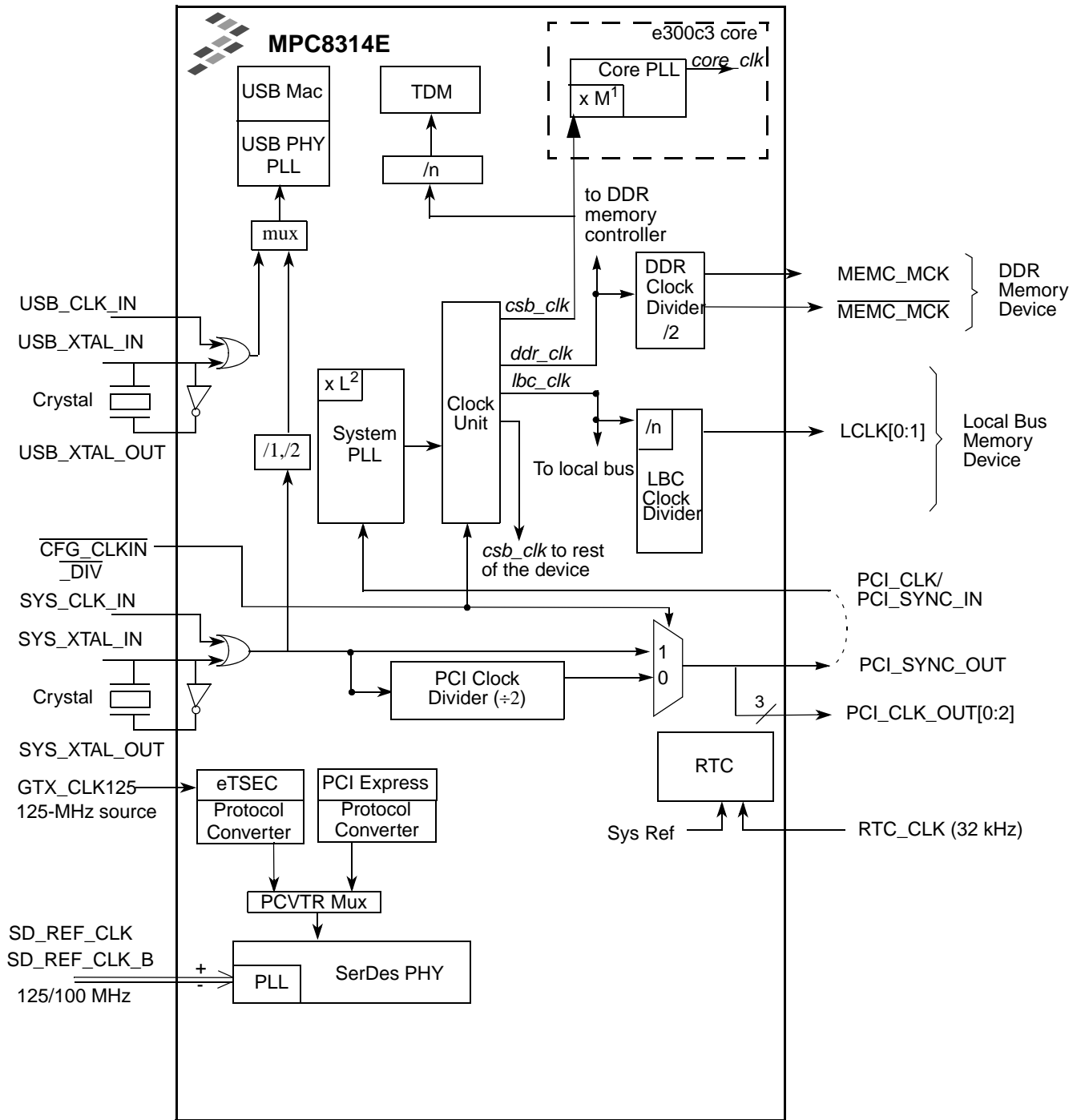

¹ Multiplication factor $M = 1, 1.5, 2, 2.5,$ and 3 . Value is decided by RCWLR[COREPLL].

² Multiplication factor $L = 2, 3, 4$ and 5 . Value is decided by RCWLR[SPMF].

Figure 60. MPC8314E Clock Subsystem

The primary clock source can be one of two inputs, `SYS_CLK_IN` or `PCI_CLK`, depending on whether the device is configured in PCI host or PCI agent mode. When the device is configured as a PCI host device, `SYS_CLK_IN` is its primary input clock. `SYS_CLK_IN` feeds the PCI clock divider ($\div 2$) and the multiplexors for `PCI_SYNC_OUT` and `PCI_CLK_OUT`. The `CFG_SYS_CLKIN_DIV` configuration input selects whether `SYS_CLK_IN` or `SYS_CLK_IN/2` is driven out on the `PCI_SYNC_OUT` signal.

`PCI_SYNC_OUT` is connected externally to `PCI_SYNC_IN` to allow the internal clock subsystem to synchronize to the system PCI clocks. `PCI_SYNC_OUT` must be connected properly to `PCI_SYNC_IN`, with equal delay to all PCI agent devices in the system, to allow the device to function. When the device is configured as a PCI agent device, `PCI_CLK` is the primary input clock. When the device is configured as a PCI agent device the `SYS_CLK_IN` signal should be tied to GND.

As shown in [Figure 60](#), the primary clock input (frequency) is multiplied up by the system phase-locked loop (PLL) and the clock unit to create the coherent system bus clock (`csb_clk`), the internal clock for the DDR controller (`ddr_clk`), and the internal clock for the local bus interface unit (`lbiu_clk`).

The `csb_clk` frequency is derived from a complex set of factors that can be simplified into the following equation:

$$csb_clk = \{PCI_SYNC_IN \times (1 + \sim \overline{CFG_SYS_CLKIN_DIV})\} \times SPMF$$

In PCI host mode, $PCI_SYNC_IN \times (1 + \sim \overline{CFG_SYS_CLKIN_DIV})$ is the `SYS_CLK_IN` frequency.

The `csb_clk` serves as the clock input to the e300 core. A second PLL inside the e300 core multiplies up the `csb_clk` frequency to create the internal clock for the e300 core (`core_clk`). The system and core PLL multipliers are selected by the SPMF and COREPLL fields in the reset configuration word low (RCWL) which is loaded at power-on reset or by one of the hard-coded reset options. See Chapter 4, “Reset, Clocking, and Initialization,” in the *MPC8315E PowerQUICC II Pro Integrated Host Processor Family Reference Manual* for more information on the clock subsystem.

The internal `ddr_clk` frequency is determined by the following equation:

$$ddr_clk = csb_clk \times (1 + RCWL[DDRCM])$$

Note that `ddr_clk` is not the external memory bus frequency; `ddr_clk` passes through the DDR clock divider ($\div 2$) to create the differential DDR memory bus clock outputs (`MCK` and `MCK`). However, the data rate is the same frequency as `ddr_clk`.

The internal `lbiu_clk` frequency is determined by the following equation:

$$lbiu_clk = csb_clk \times (1 + RCWL[LBCM])$$

Note that `lbiu_clk` is not the external local bus frequency; `lbiu_clk` passes through the LBIU clock divider to create the external local bus clock outputs (`LCLK[0:1]`). The LBIU clock divider ratio is controlled by `LCRR[CLKDIV]`.

In addition, some of the internal units may be required to be shut off or operate at lower frequency than the `csb_clk` frequency. Those units have a default clock ratio that can be configured by a memory mapped register after the device comes out of reset. [Table 67](#) specifies which units have a configurable clock frequency.

Table 67. Configurable Clock Units

Unit	Default Frequency	Options
eTSEC1	<i>csb_clk</i>	Off, <i>csb_clk</i> , <i>csb_clk/2</i> , <i>csb_clk/3</i>
eTSEC2	<i>csb_clk</i>	Off, <i>csb_clk</i> , <i>csb_clk/2</i> , <i>csb_clk/3</i>
Security Core, I2C, SAP, TPR	<i>csb_clk</i>	Off, <i>csb_clk</i> , <i>csb_clk/2</i> , <i>csb_clk/3</i>
USB DR	<i>csb_clk</i>	Off, <i>csb_clk</i> , <i>csb_clk/2</i> , <i>csb_clk/3</i>
PCI and DMA complex	<i>csb_clk</i>	Off, <i>csb_clk</i>
PCI Express	<i>csb_clk</i>	Off, <i>csb_clk</i>
Serial ATA	<i>csb_clk</i>	Off, <i>csb_clk</i> , <i>csb_clk/2</i> , <i>csb_clk/3</i>

This table provides the operating frequencies for the TEPBGA II under recommended operating conditions (see [Table 2](#)).

Table 68. Operating Frequencies for TEPBGA II

Characteristic ¹	Max Operating Frequency	Unit
e300 core frequency (<i>core_clk</i>)	400	MHz
Coherent system bus frequency (<i>csb_clk</i>)	133	MHz
DDR1/2 memory bus frequency (MCK) ²	133	MHz
Local bus frequency (LCLK _n) ³	66	MHz
PCI input frequency (SYS_CLK_IN or PCI_CLK)	24-66	MHz

Note:

1. The SYS_CLK_IN frequency, RCWL[SPMF], and RCWL[COREPLL] settings must be chosen such that the resulting *csb_clk*, MCK, LCLK[0:1], and *core_clk* frequencies do not exceed their respective maximum or minimum operating frequencies.
2. The DDR data rate is 2x the DDR memory bus frequency.
3. The local bus frequency is 1/2, 1/4, or 1/8 of the *lbiu_clk* frequency (depending on LCRR[CLKDIV]) which is in turn 1x or 2x the *csb_clk* frequency (depending on RCWL[LBCM]).

23.1 System PLL Configuration

The system PLL is controlled by the RCWL[SPMF] parameter. [Table 69](#) shows the multiplication factor encodings for the system PLL.

NOTE

If RCWL[DDRCM] and RCWL[LBCM] are both cleared, the system PLL VCO frequency = (CSB frequency) × (System PLL VCO Divider).

If either RCWL[DDRCM] or RCWL[LBCM] are set, the system PLL VCO frequency = 2 × (CSB frequency) × (System PLL VCO Divider).

The VCO divider needs to be set properly so that the System PLL VCO frequency is in the range of 450–750 MHz.

Table 69. System PLL Multiplication Factors

RCWL[SPMF]	System PLL Multiplication Factor
0000	Reserved
0001	Reserved
0010	× 2
0011	× 3
0100	× 4
0101	× 5
0110–1111	Reserved

As described in [Section 23, “Clocking,”](#) The LBCM, DDRCM, and SPMF parameters in the reset configuration word low and the CFG_SYS_CLKIN_DIV configuration input signal select the ratio between the primary clock input (SYS_CLK_IN or PCI_CLK) and the internal coherent system bus clock (*csb_clk*). [Table 70](#) and [Table 71](#) shows the expected frequency values for the CSB frequency for select *csb_clk* to SYS_CLK_IN/PCI_SYNC_IN ratios.

Table 70. CSB Frequency Options for Host Mode

CFG_SYS_CLKIN_DIV at Reset ¹	SPMF	csb_clk : Input Clock Ratio ²	Input Clock Frequency (MHz) ²		
			24	33.33	66.67
High/Low ³	0010	2:1			133
High/Low	0011	3:1		100	—
High/Low	0100	4:1	96	133	—
High/Low	0101	5:1	120	—	—

¹ CFG_SYS_CLKIN_DIV select the ratio between SYS_CLK_IN and PCI_SYNC_OUT.
² SYS_CLK_IN is the input clock in host mode; PCI_CLK is the input clock in agent mode.
³ In the Host mode it does not matter if the value is High or Low.

Table 71. CSB Frequency Options for Agent Mode

CFG_SYS_CLKIN_DIV at Reset ¹	SPMF	csb_clk : Input Clock Ratio ²	Input Clock frequency (MHz) ²		
			25	33.33	66.67
High	0010	2: 1			133
High	0011	3: 1		100	—
High	0100	4: 1		133	—
High	0101	5: 1	120	—	—

¹ CFG_SYS_CLKIN_DIV doubles *csb_clk* if set low.
² SYS_CLK_IN is the input clock in host mode; PCI_CLK is the input clock in agent mode.

23.2 Core PLL Configuration

RCWL[COREPLL] selects the ratio between the internal coherent system bus clock (*csb_clk*) and the e300 core clock (*core_clk*). Table 72 shows the encodings for RCWL[COREPLL]. COREPLL values that are not listed in Table 72 should be considered as reserved.

NOTE

Core VCO frequency = core frequency × VCO divider

VCO divider has to be set properly so that the core VCO frequency is in the range of 400–800 MHz.

Table 72. e300 Core PLL Configuration

RCWL[COREPLL]			<i>core_clk</i> : <i>csb_clk</i> Ratio	VCO Divider ¹
0–1	2–5	6		
nn	0000	0	PLL bypassed (PLL off, <i>csb_clk</i> clocks core directly)	PLL bypassed (PLL off, <i>csb_clk</i> clocks core directly)
11	nnnn	n	N/A	N/A
00	0001	0	1:1	2
01	0001	0	1:1	4
00	0001	1	1.5:1	2
01	0001	1	1.5:1	4
00	0010	0	2:1	2
01	0010	0	2:1	4
00	0010	1	2.5:1	2
01	0010	1	2.5:1	4
00	0011	0	3:1	2
01	0011	0	3:1	4

¹ Core VCO frequency = core frequency × VCO divider.

23.3 Suggested PLL Configurations

To simplify the PLL configurations, the MPC8314E might be separated into two clock domains. The first domain contain the CSB PLL and the core PLL. The core PLL is connected serially to the CSB PLL, and has the *csb_clk* as its input clock. The clock domains are independent, and each of their PLLs are configured separately. Both of the domains has one common input clock. Table 73 shows suggested PLL configurations for 33, 25, and 66 MHz input clocks.

Table 73. Suggested PLL Configurations

Conf. No.	SPMF	Core\PLL	Input Clock Frequency (MHz)	CSB Frequency (MHz)	Core Frequency (MHz)
1	0100	0000100	33.33	133.33	266.66
3	0010	0000100	66.67	133.33	266.66
4	0100	0000101	33.33	133.33	333.33
5	0101	0000101	25	125	312.5

Table 73. Suggested PLL Configurations

Conf. No.	SPMF	Core\PLL	Input Clock Frequency (MHz)	CSB Frequency (MHz)	Core Frequency (MHz)
6	0010	0000101	66.67	133.33	333.33
7	0101	0000110	25	125	375
8	0100	0000110	33.33	133.33	400
9	0010	0000110	66.67	133.33	400

24 Thermal

This section describes the thermal specifications of the MPC8314E.

24.1 Thermal Characteristics

This table provides the package thermal characteristics for the 620 29 × 29 mm TEPBGA II.

Table 74. Package Thermal Characteristics for TEPBGA II

Characteristic	Board type	Symbol	Value	Unit	Note
Junction to ambient natural convection	Single layer board (1s)	$R_{\theta JA}$	23	°C/W	1, 2
Junction to ambient natural convection	Four layer board (2s2p)	$R_{\theta JA}$	16	°C/W	1, 2, 3
Junction to ambient (@200 ft/min)	Single layer board (1s)	$R_{\theta JMA}$	18	°C/W	1, 3
Junction to ambient (@200 ft/min)	Four layer board (2s2p)	$R_{\theta JMA}$	13	°C/W	1, 3
Junction to board	—	$R_{\theta JB}$	8	°C/W	4
Junction to case	—	$R_{\theta JC}$	6	°C/W	5
Junction to package top	Natural convection	Ψ_{JT}	6	°C/W	6

Note:

1. Junction temperature is a function of die size, on-chip power dissipation, package thermal resistance, mounting site (board) temperature, ambient temperature, air flow, power dissipation of other components on the board, and board thermal resistance.
2. Per JEDEC JESD51-2 with the single layer board horizontal. Board meets JESD51-9 specification.
3. Per JEDEC JESD51-6 with the board horizontal.
4. Thermal resistance between the die and the printed circuit board per JEDEC JESD51-8. Board temperature is measured on the top surface of the board near the package.
5. Thermal resistance between the die and the case top surface as measured by the cold plate method (MIL SPEC-883 Method 1012.1).
6. Thermal characterization parameter indicating the temperature difference between package top and the junction temperature per JEDEC JESD51-2. When Greek letters are not available, the thermal characterization parameter is written as Psi-JT.

24.2 Thermal Management Information

For the following sections, $P_D = (V_{DD} \times I_{DD}) + P_{I/O}$ where $P_{I/O}$ is the power dissipation of the I/O drivers.

24.2.1 Estimation of Junction Temperature with Junction-to-Ambient Thermal Resistance

An estimation of the chip junction temperature, T_J , can be obtained from the equation:

$$T_J = T_A + (R_{\theta JA} \times P_D)$$

where:

T_J = junction temperature (°C)

T_A = ambient temperature for the package (°C)

$R_{\theta JA}$ = junction to ambient thermal resistance (°C/W)

P_D = power dissipation in the package (W)

The junction to ambient thermal resistance is an industry standard value that provides a quick and easy estimation of thermal performance. As a general statement, the value obtained on a single layer board is appropriate for a tightly packed printed circuit board. The value obtained on the board with the internal planes is usually appropriate if the board has low power dissipation and the components are well separated. Test cases have demonstrated that errors of a factor of two (in the quantity $T_J - T_A$) are possible.

24.2.2 Estimation of Junction Temperature with Junction-to-Board Thermal Resistance

The thermal performance of a device cannot be adequately predicted from the junction to ambient thermal resistance. The thermal performance of any component is strongly dependent on the power dissipation of surrounding components. In addition, the ambient temperature varies widely within the application. For many natural convection and especially closed box applications, the board temperature at the perimeter (edge) of the package is approximately the same as the local air temperature near the device. Specifying the local ambient conditions explicitly as the board temperature provides a more precise description of the local ambient conditions that determine the temperature of the device.

At a known board temperature, the junction temperature is estimated using the following equation:

$$T_J = T_B + (R_{\theta JB} \times P_D)$$

where:

T_J = junction temperature (°C)

T_B = board temperature at the package perimeter (°C)

$R_{\theta JB}$ = junction to board thermal resistance (°C/W) per JESD51-8

P_D = power dissipation in the package (W)

When the heat loss from the package case to the air can be ignored, acceptable predictions of junction temperature can be made. The application board should be similar to the thermal test condition: the component is soldered to a board with internal planes.

24.2.3 Experimental Determination of Junction Temperature

To determine the junction temperature of the device in the application after prototypes are available, the Thermal Characterization Parameter (Ψ_{JT}) can be used to determine the junction temperature with a measurement of the temperature at the top center of the package case using the following equation:

$$T_J = T_T + (\Psi_{JT} \times P_D)$$

where:

T_J = junction temperature (°C)

T_T = thermocouple temperature on top of package (°C)

Ψ_{JT} = junction to ambient thermal resistance (°C/W)

P_D = power dissipation in the package (W)

The thermal characterization parameter is measured per JESD51-2 specification using a 40 gauge type T thermocouple epoxied to the top center of the package case. The thermocouple should be positioned so that the thermocouple junction rests on the package. A small amount of epoxy is placed over the thermocouple junction and over about 1 mm of wire extending from the junction. The thermocouple wire is placed flat against the package case to avoid measurement errors caused by cooling effects of the thermocouple wire.

24.2.4 Heat Sinks and Junction-to-Case Thermal Resistance

In some application environments, a heat sink is required to provide the necessary thermal management of the device. When a heat sink is used, the thermal resistance is expressed as the sum of a junction to case thermal resistance and a case to ambient thermal resistance:

$$R_{\theta JA} = R_{\theta JC} + R_{\theta CA}$$

where:

$R_{\theta JA}$ = junction to ambient thermal resistance (°C/W)

$R_{\theta JC}$ = junction to case thermal resistance (°C/W)

$R_{\theta CA}$ = case to ambient thermal resistance (°C/W)

$R_{\theta JC}$ is device related and cannot be influenced by the user. The user controls the thermal environment to change the case to ambient thermal resistance, $R_{\theta CA}$. For instance, the user can change the size of the heat sink, the air flow around the device, the interface material, the mounting arrangement on printed circuit board, or change the thermal dissipation on the printed circuit board surrounding the device.

To illustrate the thermal performance of the devices with heat sinks, the thermal performance has been simulated with a few commercially available heat sinks. The heat sink choice is determined by the application environment (temperature, air flow, adjacent component power dissipation) and the physical space available. Because there is not a standard application environment, a standard heat sink is not required.

Table 75. Heat Sinks and Junction-to-Case Thermal Resistance of MPC8314E TEPBGA II

Heat Sink Assuming Thermal Grease	Air Flow	29 × 29 mm TEBGA II
		Junction-to-Ambient Thermal Resistance
AAVID 30 x 30 x 9.4 mm Pin Fin	Natural Convection	14.4
AAVID 30 x 30 x 9.4 mm Pin Fin	0.5 m/s	11.4
AAVID 30 x 30 x 9.4 mm Pin Fin	1 m/s	10.1
AAVID 30 x 30 x 9.4 mm Pin Fin	2 m/s	8.9
AAVID 35 x 31 x 23 mm Pin Fin	Natural Convection	12.3
AAVID 35 x 31 x 23 mm Pin Fin	0.5 m/s	9.3
AAVID 35 x 31 x 23 mm Pin Fin	1 m/s	8.5
AAVID 35 x 31 x 23 mm Pin Fin	2 m/s	7.9
AAVID 43 x 41 x 16.5 mm Pin Fin	Natural Convection	12.5
AAVID 43 x 41 x 16.5 mm Pin Fin	0.5 m/s	9.7
AAVID 43 x 41 x 16.5 mm Pin Fin	1 m/s	8.5
AAVID 43 x 41 x 16.5 mm Pin Fin	2 m/s	7.7
Wakefield, 53 x 53 x 25 mm Pin Fin	Natural Convection	10.9
Wakefield, 53 x 53 x 25 mm Pin Fin	0.5 m/s	8.5
Wakefield, 53 x 53 x 25 mm Pin Fin	1 m/s	7.5
Wakefield, 53 x 53 x 25 mm Pin Fin	2 m/s	7.1

Accurate thermal design requires thermal modeling of the application environment using computational fluid dynamics software which can model both the conduction cooling and the convection cooling of the air moving through the application. Simplified thermal models of the packages can be assembled using the junction-to-case and junction-to-board thermal resistances listed in the thermal resistance table. More detailed thermal models can be made available on request.

Heat sink vendors include the following list:

Aavid Thermalloy 603-224-9988
 80 Commercial St.
 Concord, NH 03301
 Internet: www.aavidthermalloy.com

Alpha Novatech 408-749-7601
 473 Sapena Ct. #12
 Santa Clara, CA 95054
 Internet: www.alphanovatech.com

International Electronic Research Corporation (IERC) 818-842-7277
 413 North Moss St.
 Burbank, CA 91502
 Internet: www.ctscorp.com

Thermal

Millennium Electronics (MEI) Loroco Sites 671 East Brokaw Road San Jose, CA 95112 Internet: www.mei-thermal.com	408-436-8770
Tyco Electronics Chip Coolers™ P.O. Box 3668 Harrisburg, PA 17105 Internet: www.tycoelectronics.com	800-522-6752
Wakefield Engineering 33 Bridge St. Pelham, NH 03076 Internet: www.wakefield.com	603-635-2800

Interface material vendors include the following:

Chomerics, Inc. 77 Dragon Ct. Woburn, MA 01801 Internet: www.chomerics.com	781-935-4850
Dow-Corning Corporation Corporate Center PO BOX 994 Midland, MI 48686-0994 Internet: www.dowcorning.com	800-248-2481
Shin-Etsu MicroSi, Inc. 10028 S. 51st St. Phoenix, AZ 85044 Internet: www.microsi.com	888-642-7674
The Bergquist Company 18930 West 78th St. Chanhassen, MN 55317 Internet: www.bergquistcompany.com	800-347-4572

24.3 Heat Sink Attachment

When attaching heat sinks to these devices, an interface material is required. The best method is to use thermal grease and a spring clip. The spring clip should connect to the printed circuit board, either to the board itself, to hooks soldered to the board, or to a plastic stiffener. Avoid attachment forces which would lift the edge of the package or peel the package from the board. Such peeling forces reduce the solder joint lifetime of the package. Recommended maximum force on the top of the package is 10 lb force (45 Newtons). If an adhesive attachment is planned, the adhesive should be intended for attachment to painted or plastic surfaces and its performance verified under the application requirements.

24.3.1 Experimental Determination of the Junction Temperature with a Heat Sink

When heat sink is used, the junction temperature is determined from a thermocouple inserted at the interface between the case of the package and the interface material. A clearance slot or hole is normally required in the heat sink. Minimizing the size of the clearance is important to minimize the change in thermal performance caused by removing part of the thermal interface to the heat sink temperature and then back calculate the case temperature using a separate measurement of the thermal resistance of the interface. From this case temperature, the junction temperature is determined from the junction to case thermal resistance.

$$T_J = T_C + (R_{\theta JC} \times P_D)$$

Where

T_C is the case temperature of the package

$R_{\theta JC}$ is the junction-to-case thermal resistance

P_D is the power dissipation

25 System Design Information

This section provides electrical and thermal design recommendations for successful application of the MPC8314E.

25.1 System Clocking

The MPC8314E includes two PLLs.

1. The platform PLL (AVDD2) generates the platform clock from the externally supplied SYS_CLK_IN input. The frequency ratio between the platform and SYS_CLK_IN is selected using the platform PLL ratio configuration bits as described in [Section 23.1, “System PLL Configuration.”](#)
2. The e300 Core PLL (AVDD1) generates the core clock as a slave to the platform clock. The frequency ratio between the e300 core clock and the platform clock is selected using the e300 PLL ratio configuration bits as described in [Section 23.2, “Core PLL Configuration.”](#)

25.2 PLL Power Supply Filtering

Each of the PLLs listed above is provided with power through independent power supply pins (AVDD1, AVDD2 respectively). The AV_{DD} level should always be equivalent to VDD, and preferably these voltages are derived directly from VDD through a low frequency filter scheme such as the following.

There are a number of ways to reliably provide power to the PLLs, but the recommended solution is to provide independent filter circuits as illustrated in [Figure 61](#), one to each of the AV_{DD} pins. By providing independent filters to each PLL the opportunity to cause noise injection from one PLL to the other is reduced.

This circuit is intended to filter noise in the PLLs resonant frequency range from a 500 kHz to 10 MHz range. It should be built with surface mount capacitors with minimum Effective Series Inductance (ESL). Consistent with the recommendations of Dr. Howard Johnson in *High Speed Digital Design: A Handbook of Black Magic* (Prentice Hall, 1993), multiple small capacitors of equal value are recommended over a single large value capacitor.

Each circuit should be placed as close as possible to the specific AV_{DD} pin being supplied to minimize noise coupled from nearby circuits. It should be possible to route directly from the capacitors to the AV_{DD} pin, which is on the periphery of package, without the inductance of vias. Note that the RC filter results in lower voltage level on AVDD. This does not imply that the DC specification can be relaxed.

This figure shows the PLL power supply filter circuit.

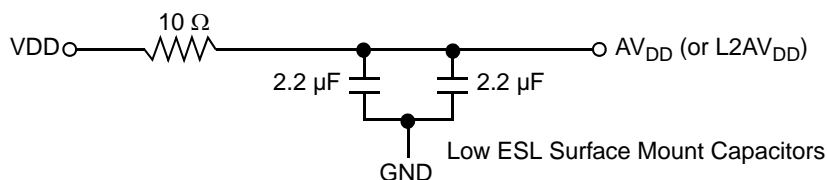

Figure 61. PLL Power Supply Filter Circuit

25.3 Decoupling Recommendations

Due to large address and data buses, and high operating frequencies, the device can generate transient power surges and high frequency noise in its power supply, especially while driving large capacitive loads. This noise must be prevented from reaching other components in the MPC8314E system, and the MPC8314E itself requires a clean, tightly regulated source of power. Therefore, it is recommended that the system designer place at least one decoupling capacitor at each VDD, NVDD, GVDD, and LVDD pins of the device. These decoupling capacitors should receive their power from separate VDD, NVDD, GVDD, LVDD, and GND power planes in the PCB, utilizing thick and short traces to minimize inductance. Capacitors may be placed directly under the device using a standard escape pattern. Others may surround the part.

These capacitors should have a value of 0.01 or 0.1 μF . Only ceramic SMT (surface mount technology) capacitors should be used to minimize lead inductance, preferably 0402 or 0603 sizes.

In addition, it is recommended that there be several bulk storage capacitors distributed around the PCB, feeding the VDD, NVDD, GVDD, and LVDD planes, to enable quick recharging of the smaller chip capacitors. These bulk capacitors should have a low ESR (equivalent series resistance) rating to ensure the quick response time necessary. They should also be connected to the power and ground planes through two vias to minimize inductance. Suggested bulk capacitors—100–330 μF (AVX TPS tantalum or Sanyo OSCON).

25.4 Connection Recommendations

To ensure reliable operation, it is highly recommended to connect unused inputs to an appropriate signal level. Unused active low inputs should be tied to NVDD, GVDD, or LVDD as required. Unused active high inputs should be connected to GND. All NC (no-connect) signals must remain unconnected.

Power and ground connections must be made to all external VDD, GVDD, LVDD, NVDD, and GND pins of the device.

25.5 Output Buffer DC Impedance

The MPC8314E drivers are characterized over process, voltage, and temperature. For all buses, the driver is a push-pull single-ended driver type (open drain for I²C).

To measure Z_0 for the single-ended drivers, an external resistor is connected from the chip pad to NVDD or GND. Then, the value of each resistor is varied until the pad voltage is NVDD/2 (see Figure 62). The output impedance is the average of two components, the resistances of the pull-up and pull-down devices. When data is held high, SW1 is closed (SW2 is open) and R_P is trimmed until the voltage at the pad equals NVDD/2. R_P then becomes the resistance of the pull-up devices. R_P and R_N are designed to be close to each other in value. Then, $Z_0 = (R_P + R_N)/2$.

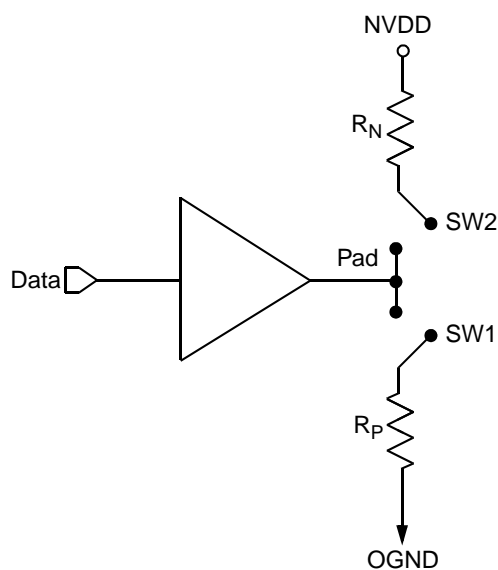

Figure 62. Driver Impedance Measurement

The value of this resistance and the strength of the driver's current source can be found by making two measurements. First, the output voltage is measured while driving logic 1 without an external differential termination resistor. The measured voltage is $V_1 = R_{\text{source}} \times I_{\text{source}}$. Second, the output voltage is measured while driving logic 1 with an external precision differential termination resistor of value R_{term} . The measured voltage is $V_2 = (1/(1/R_1 + 1/R_2)) \times I_{\text{source}}$. Solving for the output impedance gives $R_{\text{source}} = R_{\text{term}} \times (V_1/V_2 - 1)$. The drive current is then $I_{\text{source}} = V_1/R_{\text{source}}$.

This table summarizes the signal impedance targets. The driver impedance are targeted at minimum VDD, nominal NVDD, 105°C.

Table 76. Impedance Characteristics

Impedance	Local Bus, Ethernet, DUART, Control, Configuration, Power Management	PCI Signals (not including PCI Output Clocks)	PCI Output Clocks (including PCI_SYNC_OUT)	DDR DRAM	Symbol	Unit
R _N	42 Target	25 Target	42 Target	20 Target	Z ₀	Ω
R _P	42 Target	25 Target	42 Target	20 Target	Z ₀	Ω
Differential	NA	NA	NA	NA	Z _{DIFF}	Ω

Note: Nominal supply voltages. See [Table 1](#), T_j = 105°C.

25.6 Configuration Pin Multiplexing

The MPC8314E provides the user with power-on configuration options that can be set through the use of external pull-up or pull-down resistors of 4.7 kΩ on certain output pins (see customer visible configuration pins). These pins are generally used as output only pins in normal operation.

While $\overline{\text{HRESET}}$ is asserted however, these pins are treated as inputs. The value presented on these pins while $\overline{\text{HRESET}}$ is asserted, is latched when $\overline{\text{PORESET}}$ deasserts, at which time the input receiver is disabled and the I/O circuit takes on its normal function. Careful board layout with stubless connections to these pull-up/pull-down resistors coupled with the large value of the pull-up/pull-down resistor should minimize the disruption of signal quality or speed for output pins thus configured.

25.7 Pull-Up Resistor Requirements

The MPC8314E requires high resistance pull-up resistors (10 kΩ is recommended) on open drain type pins including I²C pins and EPIC interrupt pins.

For more information on required pull up resistors and the connections required for JTAG interface, see AN3438, MPC8315 Design Checklist

26 Ordering Information

Ordering information for the parts fully covered by this specification document is provided in [Section 26.1, “Part Numbers Fully Addressed by this Document.”](#)

26.1 Part Numbers Fully Addressed by this Document

This table provides the Freescale part numbering nomenclature for the MPC8314E. Note that the individual part numbers correspond to a maximum processor core frequency. For available frequencies, contact your local Freescale sales office. In addition to the processor frequency, the part numbering scheme

also includes an application modifier which may specify special application conditions. Each part number also contains a revision code which refers to the die mask revision number.

Table 77. Part Numbering Nomenclature

MPC	8314	E	C	VR	AG	D	A
Product Code	Part Identifier	Encryption Acceleration	Temperature Range³	Package¹	e300 Core Frequency²	DDR Frequency	Revision Level
MPC	8314	Blank = Not included E = included	Blank = 0 to 105°C C = -40 to 105°C	VR= Pb Free TEPBGA II	AD = 266 MHz AF = 333 MHz AG = 400 MHz	D = 266 MHz	Contact local Freescale sales office

Note:

1. See [Section 22, "Package and Pin Listings,"](#) for more information on available package types.
2. Processor core frequencies supported by parts addressed by this specification only. Not all parts described in this specification support all core frequencies. Additionally, parts addressed by electric may support other maximum core frequencies.
3. Contact your local Freescale field applications engineer (FAE).

This table shows the SVR settings by device and package type.

Table 78. SVR Settings

Device	Package	SVR (Rev 1.0)	SVR (Rev 1.1)	SVR (Rev 1.2)
MPC8314E	TEPBGA II	0x80B6_0010	0x80B6_0011	0x80B6_0012
MPC8314	TEPBGA II	0x80B7_0010	0x80B7_0011	0x80B7_0012

Note:

1. PVR = 8085_0020 for all devices and revisions in this table.

27 Revision History

This table summarizes a revision history for this document.

Table 79. Revision History

Revision	Date	Substantive Change(s)
2	11/2011	<ul style="list-style-type: none"> • In Table 66: <ul style="list-style-type: none"> – Corrected Note 10 to pull down. – Added pull up information.
1	11/2011	<ul style="list-style-type: none"> • Added Notes 4, 5, 6, and 7 in Table 2. • In Table 6: <ul style="list-style-type: none"> – Decoupled PCI_CLK and SYS_CLK_IN rise and fall times. – Relaxed maximum rise/fall time of SYS_CLK_IN from 1.2 ns to 4 ns. – Modified Note 2. – Updated SYS_CLK_IN/PCI_CLK frequency from 66 MHz to 66.67 MHz. • Added Note 4 to Table 9. • Added a note stating “eTSEC should be interfaced with peripheral operating at same voltage level.” in Section 9.1.1, “MII, RMI, RGMII, and RTBI DC Electrical Characteristics.” • Added a note in Table 26 stating “The frequency of RX_CLK should not exceed the TX_CLK by more than 300 ppm.” • Added a note in Table 29 stating “The frequency of RX_CLK should not exceed the GTX_CLK125 by more than 300 ppm • In Table 42, changed min/max values of t_{CLK_TOL} from 0.05 to 0.005. • Added t_{LALHOV} parameter to Table 44 • Replaced 50 Ω with 50 Ω in Section 16.5, “Receiver Compliance Eye Diagrams.” • In Table 66: <ul style="list-style-type: none"> – Added Pull up and Pull down information. – Removed Note 2 from TSEC_MDIO. • Removed configuration 2 from Table 73. • Removed Preliminary from Section 24, “Thermal.” • Removed MDIO signal from Section 25.7, “Pull-Up Resistor Requirements” as this signal is not open drain. • Replaced LCCR with LCRR throughout. • Replaced SYS_CLKIN with SYS_CLK_IN throughout. • Replaced all LBIUCM with LBCM. • Replaced all SYS_CR_CLK_IN and SYS_CR_CLK_OUT with SYS_XTAL_IN and SYS_XTAL_OUT, respectively. Replaced all USB_CR_CLK_IN and USB_CR_CLK_OUT with USB_XTAL_IN and USB_XTAL_OUT, respectively. • Added rise/fall time spec for TDM CLK
0	05/2009	Initial public release

How to Reach Us:

Home Page:

www.freescale.com

Web Support:

<http://www.freescale.com/support>

USA/Europe or Locations Not Listed:

Freescale Semiconductor, Inc.
Technical Information Center, EL516
2100 East Elliot Road
Tempe, Arizona 85284
1-800-521-6274 or
+1-480-768-2130
www.freescale.com/support

Europe, Middle East, and Africa:

Freescale Halbleiter Deutschland GmbH
Technical Information Center
Schatzbogen 7
81829 Muenchen, Germany
+44 1296 380 456 (English)
+46 8 52200080 (English)
+49 89 92103 559 (German)
+33 1 69 35 48 48 (French)
www.freescale.com/support

Japan:

Freescale Semiconductor Japan Ltd.
Headquarters
ARCO Tower 15F
1-8-1, Shimo-Meguro, Meguro-ku
Tokyo 153-0064
Japan
0120 191014 or
+81 3 5437 9125
support.japan@freescale.com

Asia/Pacific:

Freescale Semiconductor China Ltd.
Exchange Building 23F
No. 118 Jianguo Road
Chaoyang District
Beijing 100022
China
+86 10 5879 8000
support.asia@freescale.com

For Literature Requests Only:

Freescale Semiconductor
Literature Distribution Center
1-800 441-2447 or
+1-303-675-2140
Fax: +1-303-675-2150
LDCForFreescaleSemiconductor@hibbertgroup.com

Information in this document is provided solely to enable system and software implementers to use Freescale Semiconductor products. There are no express or implied copyright licenses granted hereunder to design or fabricate any integrated circuits or integrated circuits based on the information in this document.

Freescale Semiconductor reserves the right to make changes without further notice to any products herein. Freescale Semiconductor makes no warranty, representation or guarantee regarding the suitability of its products for any particular purpose, nor does Freescale Semiconductor assume any liability arising out of the application or use of any product or circuit, and specifically disclaims any and all liability, including without limitation consequential or incidental damages. "Typical" parameters which may be provided in Freescale Semiconductor data sheets and/or specifications can and do vary in different applications and actual performance may vary over time. All operating parameters, including "Typicals" must be validated for each customer application by customer's technical experts. Freescale Semiconductor does not convey any license under its patent rights nor the rights of others. Freescale Semiconductor products are not designed, intended, or authorized for use as components in systems intended for surgical implant into the body, or other applications intended to support or sustain life, or for any other application in which the failure of the Freescale Semiconductor product could create a situation where personal injury or death may occur. Should Buyer purchase or use Freescale Semiconductor products for any such unintended or unauthorized application, Buyer shall indemnify and hold Freescale Semiconductor and its officers, employees, subsidiaries, affiliates, and distributors harmless against all claims, costs, damages, and expenses, and reasonable attorney fees arising out of, directly or indirectly, any claim of personal injury or death associated with such unintended or unauthorized use, even if such claim alleges that Freescale Semiconductor was negligent regarding the design or manufacture of the part.

Freescale and the Freescale logo are trademarks of Freescale Semiconductor, Inc. Reg. U.S. Pat. & Tm. Off. QorIQ is a trademark of Freescale Semiconductor, Inc. All other product or service names are the property of their respective owners. The Power Architecture and Power.org word marks and the Power and Power.org logos and related marks are trademarks and service marks licensed by Power.org.
© 2011 Freescale Semiconductor, Inc.



Компания «Life Electronics» занимается поставками электронных компонентов импортного и отечественного производства от производителей и со складов крупных дистрибьюторов Европы, Америки и Азии.

С конца 2013 года компания активно расширяет линейку поставок компонентов по направлению коаксиальный кабель, кварцевые генераторы и конденсаторы (керамические, пленочные, электролитические), за счёт заключения дистрибьюторских договоров

Мы предлагаем:

- Конкурентоспособные цены и скидки постоянным клиентам.
- Специальные условия для постоянных клиентов.
- Подбор аналогов.
- Поставку компонентов в любых объемах, удовлетворяющих вашим потребностям.
- Приемлемые сроки поставки, возможна ускоренная поставка.
- Доставку товара в любую точку России и стран СНГ.
- Комплексную поставку.
- Работу по проектам и поставку образцов.
- Формирование склада под заказчика.
- Сертификаты соответствия на поставляемую продукцию (по желанию клиента).
- Тестирование поставляемой продукции.
- Поставку компонентов, требующих военную и космическую приемку.
- Входной контроль качества.
- Наличие сертификата ISO.

В составе нашей компании организован Конструкторский отдел, призванный помогать разработчикам, и инженерам.

Конструкторский отдел помогает осуществить:

- Регистрацию проекта у производителя компонентов.
- Техническую поддержку проекта.
- Защиту от снятия компонента с производства.
- Оценку стоимости проекта по компонентам.
- Изготовление тестовой платы монтаж и пусконаладочные работы.



Тел: +7 (812) 336 43 04 (многоканальный)

Email: org@lifeelectronics.ru