

This drawing involves proprietary design rights of Tyco Electronics Corporation, and all design, manufacture, reproduction, use and sale rights regarding the same are expressly reserved. It is submitted for a specific purpose and the recipient by accepting this drawing, assumes custody and control and agrees to take reasonable precautions; (a) that this drawing will not be copied and reproduced, in whole or in part, or its contents revealed in any manner, or to any person except to meet the purpose for which it was delivered and (b) that any special features peculiar to this design will not be incorporated in other projects without the expressed written permission of Tyco Electronics Corporation.

REVISIONS

EC	REV	DESCRIPTION	DATE
0S1Q-0029-05	A	NEW RELEASE	01/19/05

8. ITEMS PROVIDED TO THIS SPECIFICATION TO BE PERMANENTLY IDENTIFIED PER THE FOLLOWING IDENTIFIER:

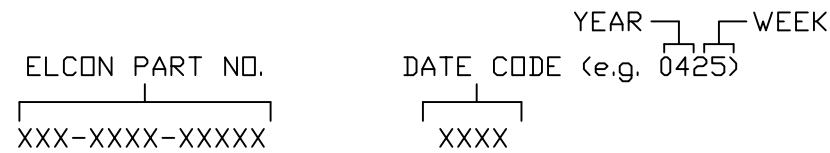

7. RECOMMENDED PRESSING TOOL:
 FIX00058 FOR PART NUMBER 285-0102-01300.
 CONTACT ELCON FOR TOOLING QUOTE OR TO ORDER.

6. EXAMPLE PCB CONFIGURATION.

5. THIS 2X2 SEGMENT CONFIGURATION SHOWN IS FOR REFERENCE ONLY. COMBINATION OF MULTIPLE NUMBERS OF 2 AND 3 SEGMENT MODULES COULD BE USED PER USER PREFERENCE. OVERALL COMBINATION SHOULD NOT EXCEED 8.0" IN LENGTH.

4. SOCKETS ACCEPT 1.6 [.062] ±10% THICK PC BOARD.

3. FINISHES:

CONTACTS: SELECTIVE GOLD PER MIL-G-45204, TYPE II, CLASS 0, .000030" MIN. THK, OVER NICKEL PER QQ-N-290, CLASS 2, .000040" MIN. THICK.

TERMINALS: TIN PLATE, MATTE FINISH, .000100" MINIMUM THICKNESS

2. MATERIALS:

INSULATORS: THERMOPLASTIC, GLASS REINFORCED, COLOR-BLACK, UL94V-0 FLAMMABILITY RATED.

CONTACTS: PHOSPHOR BRONZE ALLOY

1. PART NUMBER CHANGES AND OR DESIGN CHANGES AFFECTING ITEM INTERCHANGEABILITY REQUIRE PRIOR ELCON APPROVAL AND AUTHORIZATION BY REVISION TO THIS DRAWING.

NOTES: UNLESS OTHERWISE SPECIFIED;

9. PART NUMBER INFORMATION

CONNECTOR	REFERENCE TYCO PN	ELCON PART NUMBER	TERMINATION TYPE	PC TAIL LENGTH DIM "A"	RECOMMENDED MOUNTING BOARD	MATING BOARD
SOCKET	6651170-3	285-0102-12100	SOLDER TAIL (SHORT)	3.56 [.140] 2.54 [.100]	1.6 [.062] THICK	1.6 [.062] THICK
SOCKET	6651170-1	285-0102-12300	SOLDER TAIL (STANDARD)	5.08 [.200] 4.06 [.160]	3.2 [.125] OR THINNER	1.6 [.062] THICK
SOCKET	6651170-2	285-0102-11300	COMPLIANT TAIL	5.08 [.200] 4.06 [.160]	2.3 [.093] OR THICKER	1.6 [.062] THICK

<p>THIRD ANGLE PROJECTION</p> <p>UNLESS OTHERWISE SPECIFIED DIMENSIONS ARE IN METRIC [INCHES]</p> <p>TOLERANCES</p> <p>ANGLES ± .5°</p> <p>DECIMALS</p> <p>.XX ± .25 [.010]</p> <p>.X ± .5 [.020]</p>	DRAWN R. F. A.	DATE 01/19/05	Tyco Electronics Corporation Menlo Park, Ca 94025	
	CHECKED			
	APPROVED		TITLE	
	APPROVED D. CHAU	02/11/05	SOCKET CONNECTOR, CROWN EDGE PN: 285-0102-12100/285-0102-12300 PN: 285-0102-11300	
DCA APPROVED M. ALIM	03/02/05	SIZE	DWG NUMBER	REV.
ACAD FILE NUMBER	C6651170A.DWG	B	C = 6651170	A
			DWG SCALE	2=1
			SH 1 OF 5	

This drawing involves proprietary design rights of Tyco Electronics Corporation, and all design, manufacture, reproduction, use and sale rights regarding the same are expressly reserved. It is submitted for a specific purpose and the recipient by accepting this drawing, assumes custody and control and agrees to take reasonable precautions; (a) that this drawing will not be copied and reproduced, in whole or in part, or its contents revealed in any manner, or to any person except to meet the purpose for which it was delivered and (b) that any special features peculiar to this design will not be incorporated in other projects without the expressed written permission of Tyco Electronics Corporation.

REVISIONS			
EC	REV	DESCRIPTION	DATE
		SEE SHEET 1	

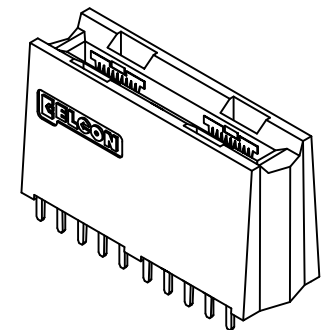
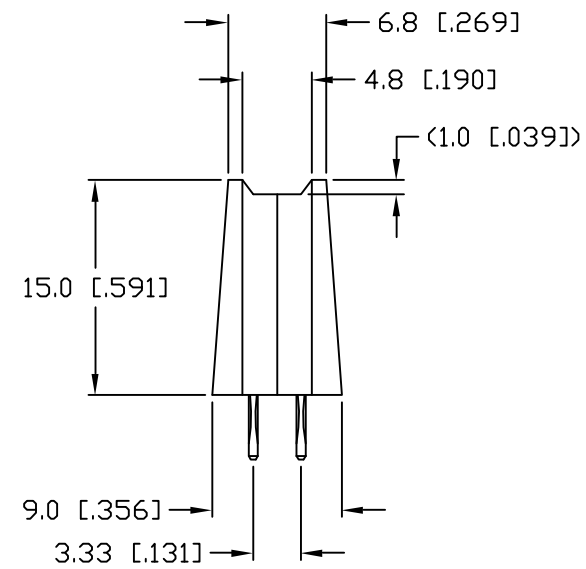
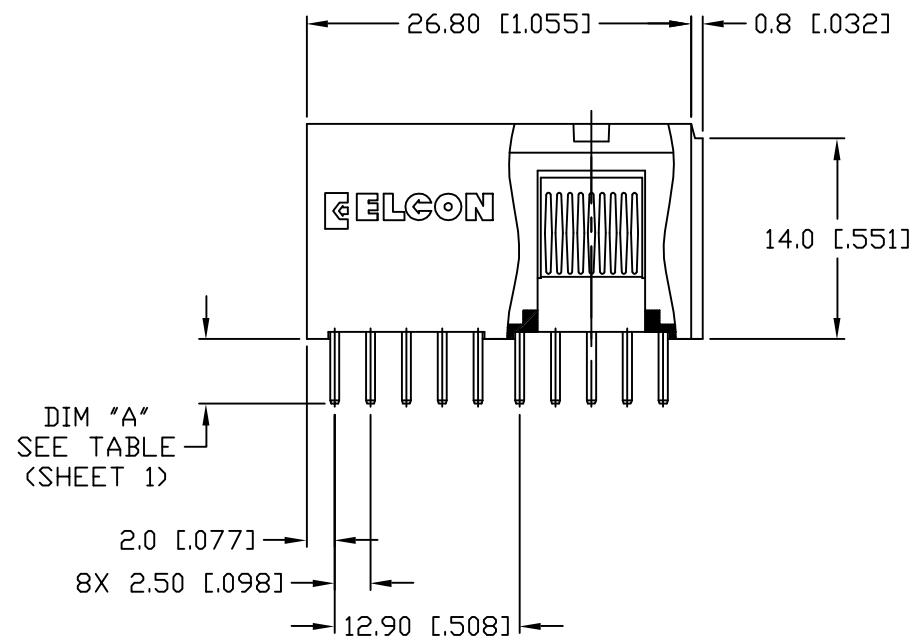
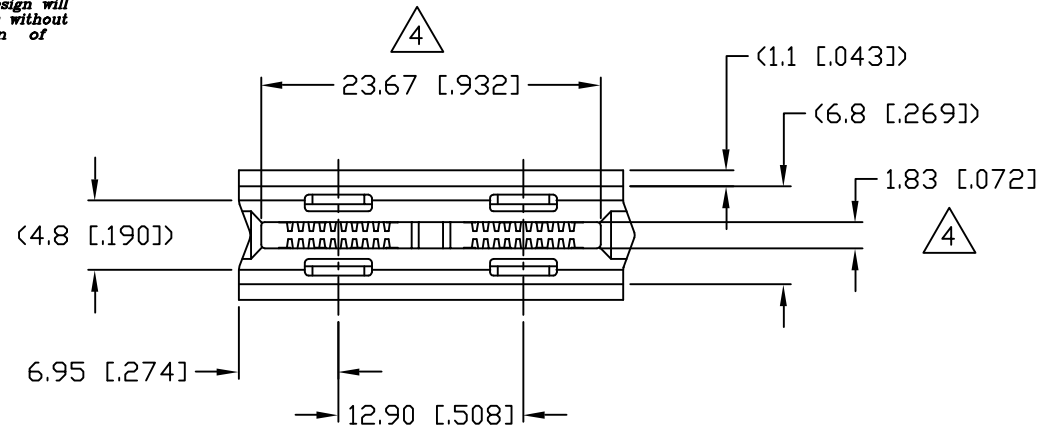

← MM OR MM [INCH] INCH THIRD ANGLE PROJECTION UNLESS OTHERWISE SPECIFIED DIMENSIONS ARE IN METRIC [INCHES] TOLERANCES ANGLES ± .5° DECIMALS .XX ± .25 [.010] .X ± .5 [.020]	DRAWN R. F. A.	DATE 01/19/05	 Tyco Electronics Corporation Menlo Park, Ca 94025 	
	CHECKED	APPROVED		TITLE SOCKET CONNECTOR, CROWN EDGE STRAIGHT, 2 SEG, 4 PWR, SOLDER, NHP PN: 285-0102-12100/12300
	APPROVED	APPROVED D. CHAU	02/11/05	SIZE B
	DCA APPROVED M. ALIM	03/02/05	DWG NUMBER C = 6651170	REV. A
ACAD FILE NUMBER C6651170A.DWG		DWG SCALE 2=1	SH 2 OF 5	

This drawing involves proprietary design rights of Tyco Electronics Corporation, and all design, manufacture, reproduction, use and sale rights regarding the same are expressly reserved. It is submitted for a specific purpose and the recipient by accepting this drawing, assumes custody and control and agrees to take reasonable precautions; (a) that this drawing will not be copied and reproduced, in whole or in part, or its contents revealed in any manner, or to any person except to meet the purpose for which it was delivered and (b) that any special features peculiar to this design will not be incorporated in other projects without the expressed written permission of Tyco Electronics Corporation.

REVISIONS			
EC	REV	DESCRIPTION	DATE
		SEE SHEET 1	

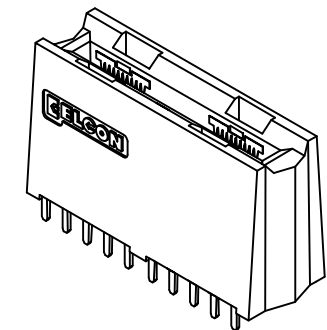
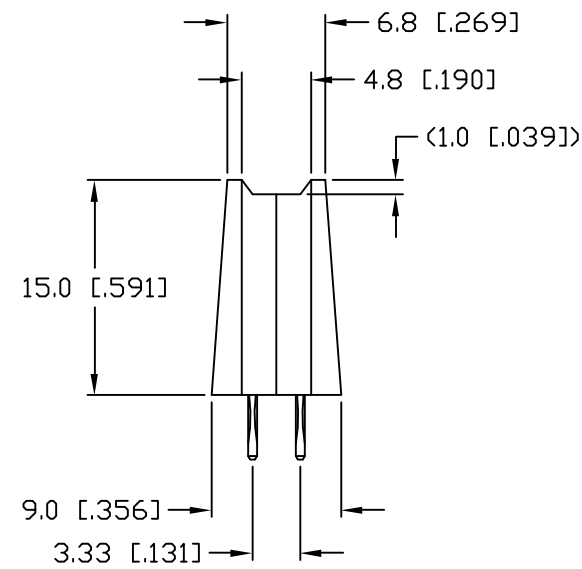
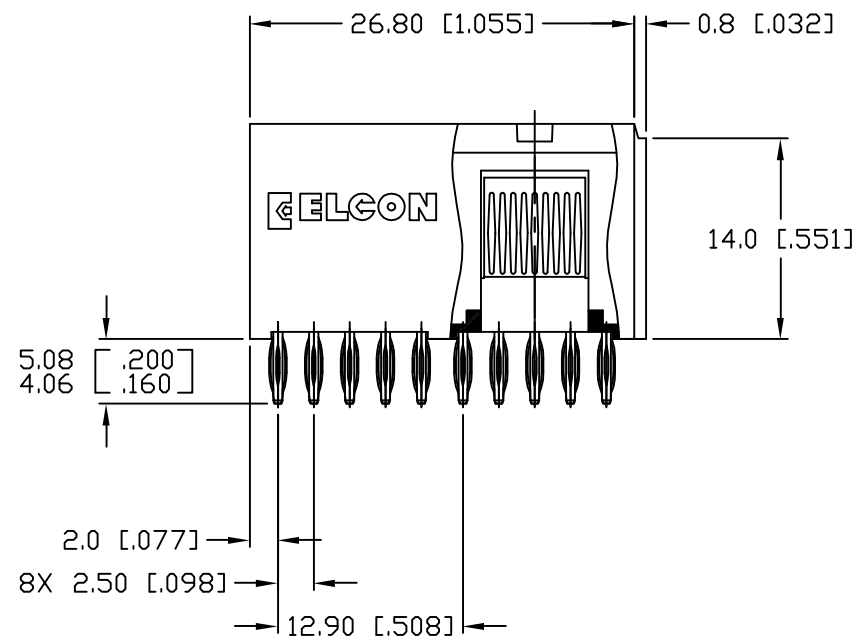
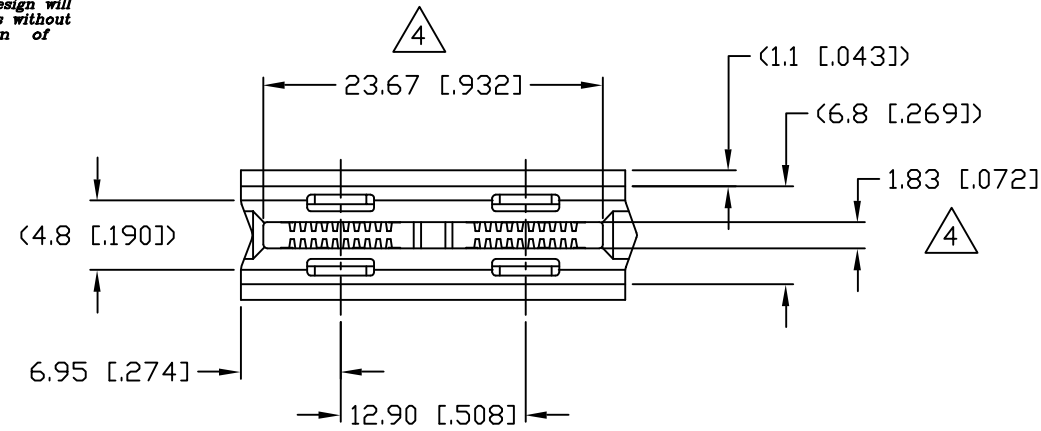

← MM OR MM [INCH] THIRD ANGLE PROJECTION UNLESS OTHERWISE SPECIFIED DIMENSIONS ARE IN METRIC [INCHES] TOLERANCES ANGLES ± .5° DECIMALS .XX ± .25 [.010] .X ± .5 [.020]	DRAWN R. F. A.	DATE 01/19/05	 Tyco Electronics Corporation Menlo Park, Ca 94025 	
	CHECKED			TITLE SOCKET CONNECTOR, CROWN EDGE STRAIGHT, 2 SEG, 4 POWER, COMPLIANT PN: 285-0102-11300
	APPROVED		APPROVED D. CHAU	DATE 02/11/05
	APPROVED M. ALIM	DATE 03/02/05	ACAD FILE NUMBER C6651170A.DWG	SIZE DWG NUMBER B C = 6651170 REV. A
DWG SCALE 2=1			SH 3 OF 5	

This drawing involves proprietary design rights of Tyco Electronics Corporation, and all design, manufacture, reproduction, use and sale rights regarding the same are expressly reserved. It is submitted for a specific purpose and the recipient by accepting this drawing, assumes custody and control and agrees to take reasonable precautions; (a) that this drawing will not be copied and reproduced, in whole or in part, or its contents revealed in any manner, or to any person except to meet the purpose for which it was delivered and (b) that any special features peculiar to this design will not be incorporated in other projects without the expressed written permission of Tyco Electronics Corporation.

REVISIONS			
EC	REV	DESCRIPTION	DATE
		SEE SHEET 1	

B

B

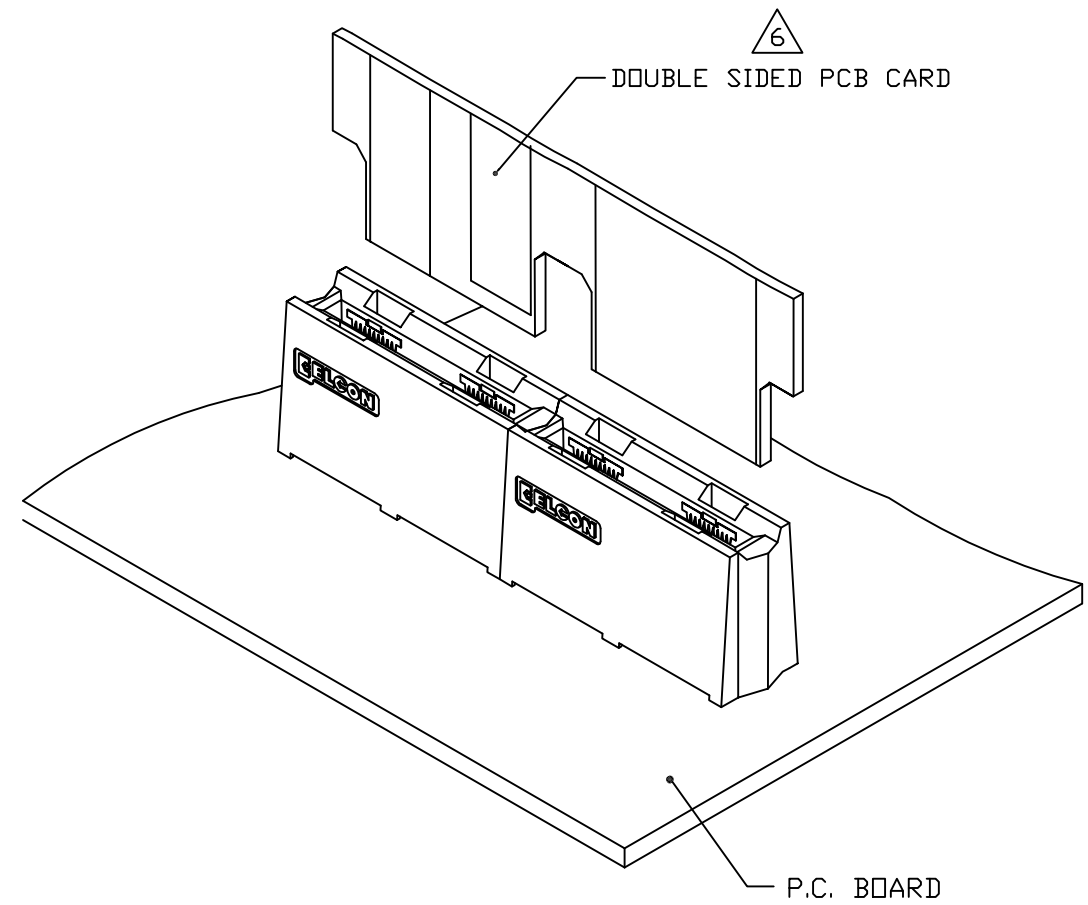
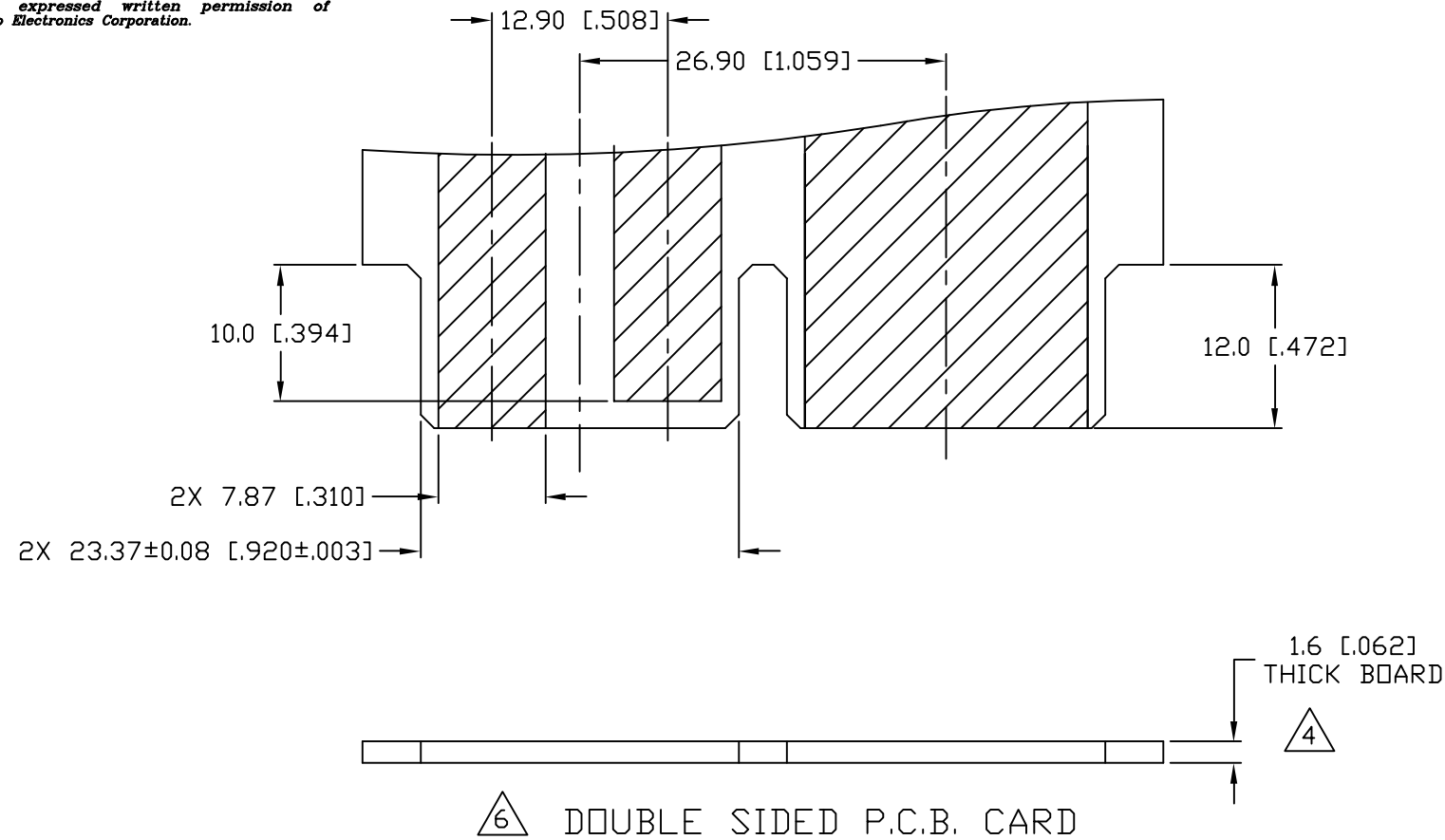

A

A

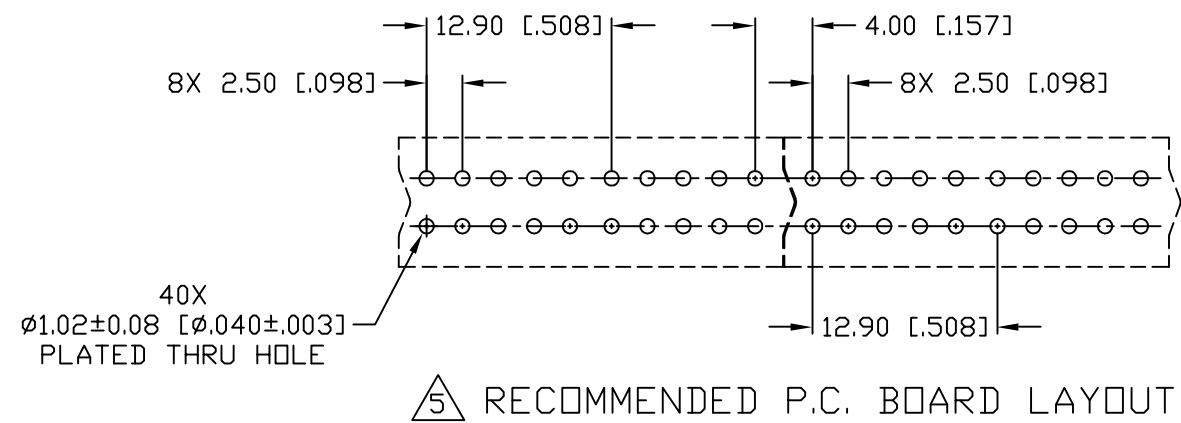

← MM INCH THIRD ANGLE PROJECTION UNLESS OTHERWISE SPECIFIED DIMENSIONS ARE IN METRIC [INCHES] TOLERANCES ANGLES ± .5° DECIMALS .XX ± .25 [.010] .X ± .5 [.020]	DRAWN R. F. A. CHECKED	DATE 01/19/05	 Tyco Electronics Corporation Menlo Park, Ca 94025
	APPROVED APPROVED D. CHAU DCA APPROVED M. ALIM ACAD FILE NUMBER C6651170A.DWG	DATE 02/11/05 03/02/05	
			DWG SCALE 2=1 SH 4 OF 5

4

3

2

1

This drawing involves proprietary design rights of Tyco Electronics Corporation, and all design, manufacture, reproduction, use and sale rights regarding the same are expressly reserved. It is submitted for a specific purpose and the recipient by accepting this drawing, assumes custody and control and agrees to take reasonable precautions; (a) that this drawing will not be copied and reproduced, in whole or in part, or its contents revealed in any manner, or to any person except to meet the purpose for which it was delivered and (b) that any special features peculiar to this design will not be incorporated in other projects without the expressed written permission of Tyco Electronics Corporation.

REVISIONS			
EC	REV	DESCRIPTION	DATE
		SEE SHEET 1	

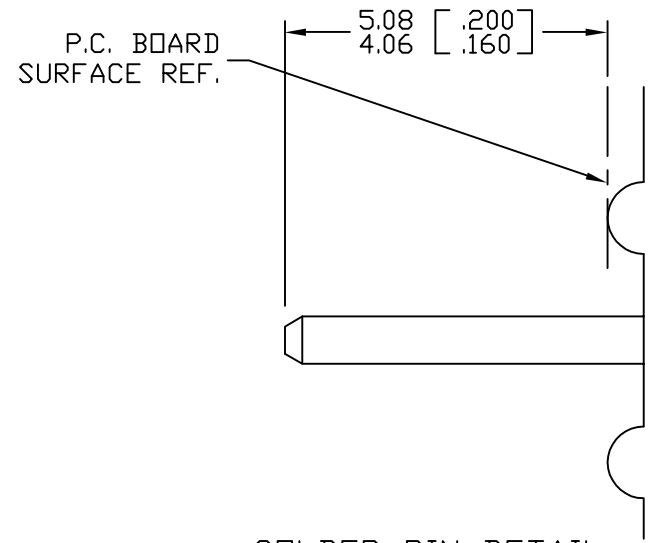

SOLDER PIN DETAIL
SCALE: 10 : 1

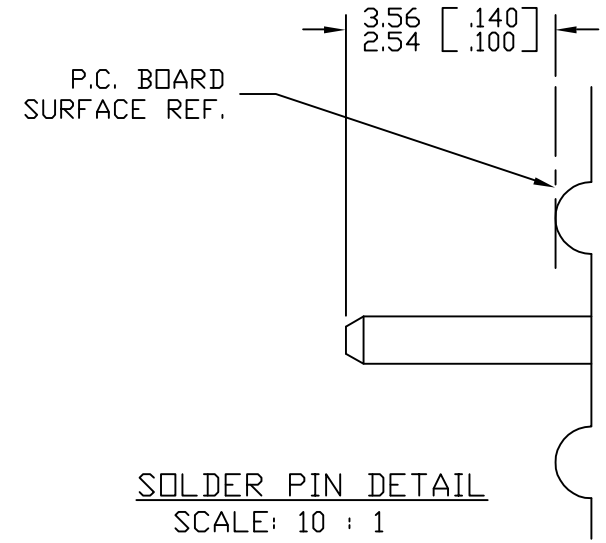

SOLDER PIN DETAIL
SCALE: 10 : 1

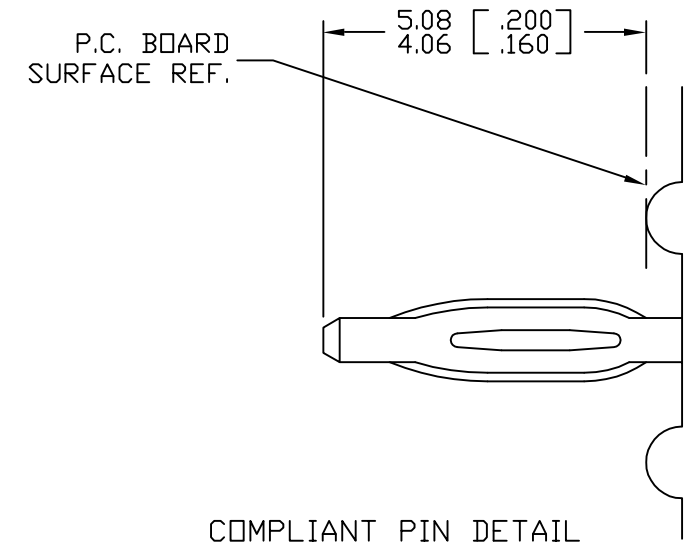

COMPLIANT PIN DETAIL
SCALE: 10 : 1

INSERTION/EXTRACTION FORCES
 MAXIMUM PUSH IN: 133.3N PER PIN [30 LBS]
 MINIMUM PUSH OUT: 44.4N PER PIN [10 LBS]

RECOMMENDED PRINTED CIRCUIT HOLE
 SOLDER OR COMPLIANT PRESS FIT
 FINISHED HOLE: $\phi 1.02$ [.040] $\pm .08$ [.003]
 DRILLED HOLE: $\phi 1.15$ [.0453] $\pm .013$ [.0005]
 COPPER PLATE: .025 [.0010] MINIMUM (PER SURFACE)
 TIN PLATE: .008 [.0003] MINIMUM (PER SURFACE)

← MM OR MM [INCH] INCH THIRD ANGLE PROJECTION UNLESS OTHERWISE SPECIFIED DIMENSIONS ARE IN METRIC [INCHES] TOLERANCES ANGLES $\pm .5^\circ$ DECIMALS .XX $\pm .25$ [.010] .X $\pm .5$ [.020]	DRAWN R. F. A.	DATE 01/19/05	 Tyco Electronics Corporation Menlo Park, Ca 94025 	
	CHECKED			TITLE
	APPROVED			USER INFORMATION SOLDER & COMPLIANT TERMINATION CROWN EDGE
	APPROVED D. CHAU	02/11/05	SIZE B	
	DCA APPROVED M. ALIM	03/02/05	DWG NUMBER C = 6651170	
	ACAD FILE NUMBER C6651170A.DWG		REV. A	
			DWG SCALE 2=1 SH 5 OF 5	

Компания «Life Electronics» занимается поставками электронных компонентов импортного и отечественного производства от производителей и со складов крупных дистрибьюторов Европы, Америки и Азии.

С конца 2013 года компания активно расширяет линейку поставок компонентов по направлению коаксиальный кабель, кварцевые генераторы и конденсаторы (керамические, пленочные, электролитические), за счёт заключения дистрибьюторских договоров

Мы предлагаем:

- Конкурентоспособные цены и скидки постоянным клиентам.
- Специальные условия для постоянных клиентов.
- Подбор аналогов.
- Поставку компонентов в любых объемах, удовлетворяющих вашим потребностям.
- Приемлемые сроки поставки, возможна ускоренная поставка.
- Доставку товара в любую точку России и стран СНГ.
- Комплексную поставку.
- Работу по проектам и поставку образцов.
- Формирование склада под заказчика.
- Сертификаты соответствия на поставляемую продукцию (по желанию клиента).
- Тестирование поставляемой продукции.
- Поставку компонентов, требующих военную и космическую приемку.
- Входной контроль качества.
- Наличие сертификата ISO.

В составе нашей компании организован Конструкторский отдел, призванный помогать разработчикам, и инженерам.

Конструкторский отдел помогает осуществить:

- Регистрацию проекта у производителя компонентов.
- Техническую поддержку проекта.
- Защиту от снятия компонента с производства.
- Оценку стоимости проекта по компонентам.
- Изготовление тестовой платы монтаж и пусконаладочные работы.



Тел: +7 (812) 336 43 04 (многоканальный)

Email: org@lifeelectronics.ru