



ON Semiconductor®

## FGD2736G3-F085

### EcoSPARK™ 3 270mJ, 360V, N-Channel Ignition IGBT

#### Features

- SCIS Energy = 270mJ at  $T_J = 25^\circ\text{C}$
- SCIS Energy = 170mJ at  $T_J = 150^\circ\text{C}$
- Logic Level Gate Drive
- RoHS Compliant



#### Applications

- Automotive Ignition Coil Driver Circuits
- Coil On Plug Applications

#### Package

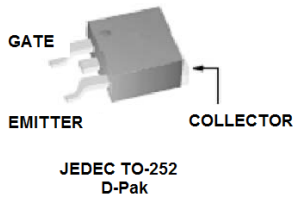

#### Symbol

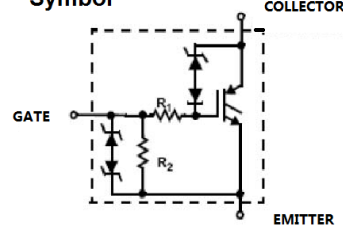

#### Absolute Maximum Ratings $T_A = 25^\circ\text{C}$ unless otherwise noted

Symbol	Parameter	Conditions	Ratings	Units
$BV_{CER}$	Collector to Emitter Breakdown Voltage ( $I_C = 1\text{mA}$ )		360	V
$BV_{ECS}$	Emitter to Collector Voltage - Reverse Battery Condition ( $I_C = 10\text{mA}$ )		28	V
$ESCIS_{25}$	$I_{SCIS} = 13.4\text{A}$ , $L = 3.0\text{mH}$ , $R_{GE} = 1\text{K}\Omega$	$T_C = 25^\circ\text{C}$	270	mJ
$ESCIS_{150}$	$I_{SCIS} = 10.8\text{A}$ , $L = 3.0\text{mH}$ , $R_{GE} = 1\text{K}\Omega$	$T_C = 150^\circ\text{C}$	170	mJ
$I_{C25}$	Collector Current Continuous, at $T_C = 25^\circ\text{C}$ , $V_{GE} = 5.0\text{V}$		21	A
$I_{C110}$	Collector Current Continuous, at $T_C = 110^\circ\text{C}$ , $V_{GE} = 5.0\text{V}$		18	A
$V_{GEM}$	Gate to Emitter Voltage Continuous		$\pm 10$	V
$P_D$	Power Dissipation Total	$T_C = 25^\circ\text{C}$	150	W
	Power Dissipation Derating	$T_C > 25^\circ\text{C}$	1	W/ $^\circ\text{C}$
$T_J$	Operating Junction Temperature Range		-40 to +175	$^\circ\text{C}$
$T_{STG}$	Storage Junction Temperature Range		-40 to +175	$^\circ\text{C}$
$T_L$	Max. Lead Temp. for Soldering (Leads at 1.6mm from case for 10s)		300	$^\circ\text{C}$
$T_{PKG}$	Max Lead Temp for soldering (Package Body for 10s)		260	$^\circ\text{C}$
ESD	Electrostatic Discharge Voltage at 100pF, 1500Ω		4	kV

FGD2736G3-F085 EcoSPARK™ 270mJ, 360V, N-Channel Ignition IGBT

**Thermal Characteristics**

$R_{\theta JC}$	Thermal Resistance Junction to Case	1	°C/W
-----------------	-------------------------------------	---	------

**Electrical Characteristics of the IGBT**  $T_A = 25^\circ\text{C}$  unless otherwise noted

Symbol	Parameter	Test Conditions	Min	Typ	Max	Units
--------	-----------	-----------------	-----	-----	-----	-------

**Off Characteristics**

$BV_{CER}$	Collector to Emitter Breakdown Voltage	$V_{GE} = 0V, I_{CE} = 2mA,$ $R_{GE} = 1K\Omega,$ $T_J = -40 \text{ to } 150^\circ\text{C}$	330	-	390	V	
$BV_{CES}$	Collector to Emitter Breakdown Voltage	$V_{GE} = 0V, I_{CE} = 10mA,$ $R_{GE} = 0\Omega,$ $T_J = -40 \text{ to } 150^\circ\text{C}$	350	-	410	V	
$BV_{ECS}$	Emitter to Collector Breakdown Voltage	$V_{GE} = 0V, I_{CE} = -75mA,$ $T_J = 25^\circ\text{C}$	28	-	-	V	
$BV_{GES}$	Gate to Emitter Breakdown Voltage	$I_{GES} = \pm 5mA$	$\pm 11$	$\pm 14$	-	V	
$I_{CER}$	Collector to Emitter Leakage Current	$V_{CE} = 250V, R_{GE} = 1K\Omega$	$T_J = 25^\circ\text{C}$	-	-	25	$\mu A$
			$T_J = 150^\circ\text{C}$	-	-	1	mA
$I_{ECS}$	Emitter to Collector Leakage Current	$V_{EC} = 24V$	$T_J = 25^\circ\text{C}$	-	-	1	mA
			$T_J = 150^\circ\text{C}$	-	-	40	
$R_1$	Series Gate Resistance		-	110	-	$\Omega$	
$R_2$	Gate to Emitter Resistance		10K	-	30K	$\Omega$	

**On Characteristics**

$V_{CE(SAT)}$	Collector to Emitter Saturation Voltage	$V_{GE} = 4V, I_{CE} = 6A$	$T_J = 25^\circ\text{C}$	-	1.25	1.35	V
$V_{CE(SAT)}$	Collector to Emitter Saturation Voltage	$V_{GE} = 4.5V, I_{CE} = 10A$	$T_J = 25^\circ\text{C}$	-	1.45	1.65	V
$V_{CE(SAT)}$	Collector to Emitter Saturation Voltage		$T_J = 150^\circ\text{C}$		1.6	1.8	V

**Dynamic Characteristics**

$Q_{G(ON)}$	Gate Charge	$V_{GE} = 5V, V_{CE} = 12V, I_{CE} = 10A$	-	18	-	nC	
$V_{GE(TH)}$	Gate to Emitter Threshold Voltage	$I_{CE} = 1mA, V_{CE} = V_{GE},$	$T_J = 25^\circ\text{C}$	1.3	1.6	2.2	V
			$T_J = 150^\circ\text{C}$	0.75	1.1	1.8	
$V_{GEP}$	Gate to Emitter Plateau Voltage	$V_{CE} = 12V, I_{CE} = 10A$	-	3.0	-	V	

**Switching Characteristics**

$t_{d(ON)R}$	Current Turn-On Delay Time-Resistive	$V_{CE} = 14V, R_L = 1\Omega$	-	0.9	4	$\mu s$
$t_{rR}$	Current Rise Time-Resistive	$V_{GE} = 5V, R_G = 1K\Omega$	-	3	7	$\mu s$
$t_{d(OFF)L}$	Current Turn-Off Delay Time-Inductive	$V_{CE} = 300V, L = 2mH,$	-	4.4	15	$\mu s$
$t_{fL}$	Current Fall Time-Inductive	$V_{GE} = 5V, R_G = 1K\Omega$	-	1.9	15	$\mu s$

**Ordering Information**

Device Marking	Device	Package	Reel Size	Tape Width	Quantity
FGD2736G3	FGD2736G3-F085	TO-252AA	330mm	16mm	2500units

## Typical Performance Curves

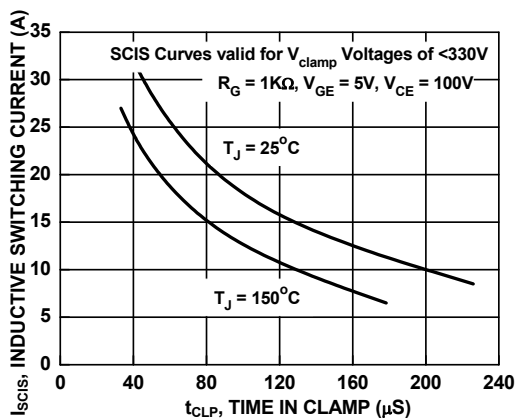

Figure 1. Self Clamped Inductive Switching Current vs. Time in Clamp

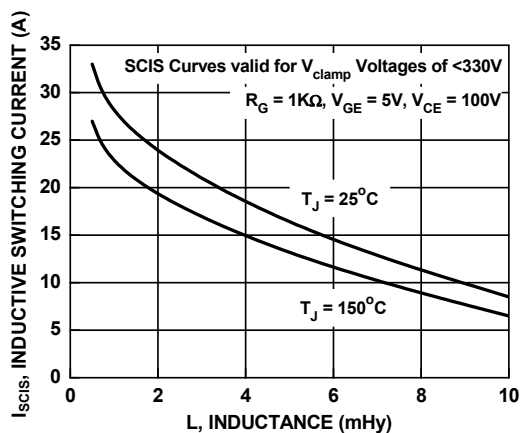

Figure 2. Self Clamped Inductive Switching Current vs. Inductance

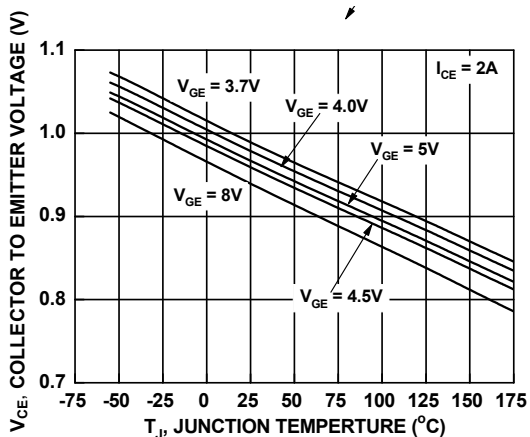

Figure 3. Collector to Emitter On-State Voltage vs. Junction Temperature

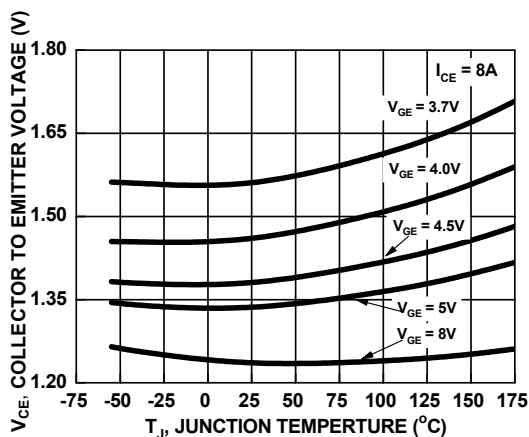

Figure 4. Collector to Emitter On-State Voltage vs. Junction Temperature

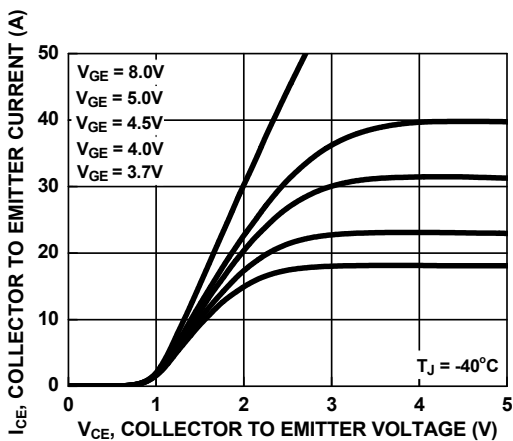

Figure 5. Collector to Emitter On-State Voltage vs. Collector Current

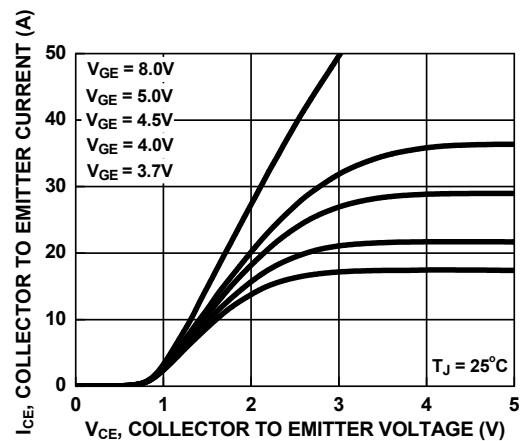

Figure 6. Collector to Emitter On-State Voltage vs. Collector Current

Typical Performance Curves (Continued)

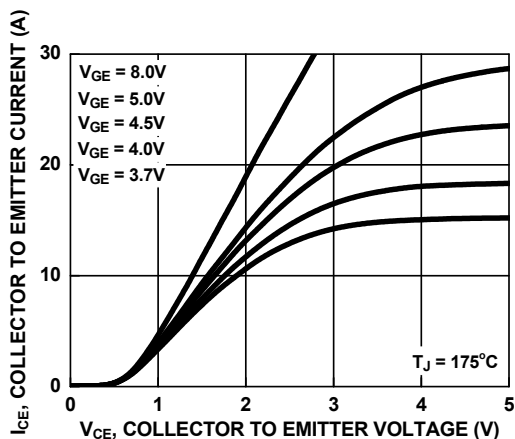

Figure 7. Collector to Emitter On-State Voltage vs. Collector Current

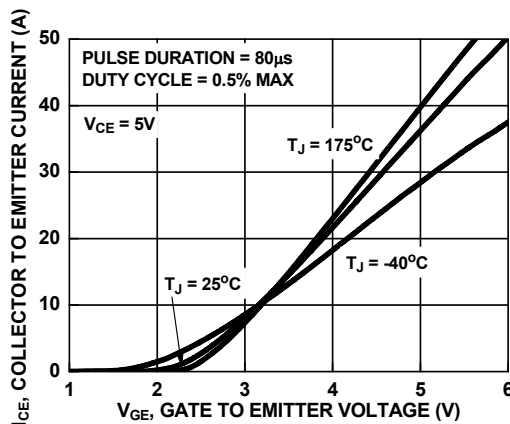

Figure 8. Transfer Characteristics

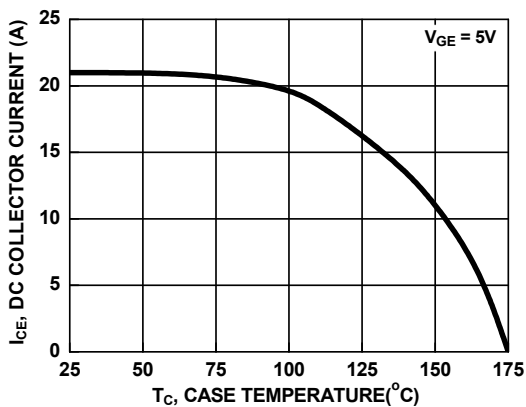

Figure 9. DC Collector Current vs. Case Temperature

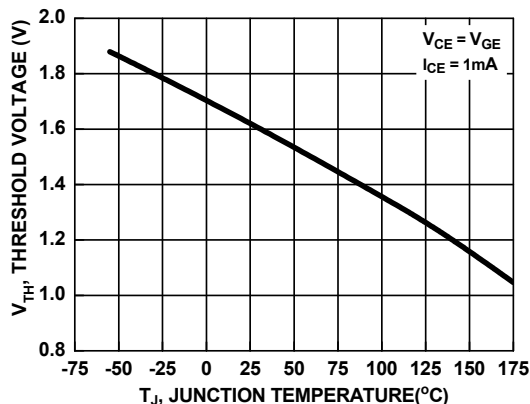

Figure 10. Threshold Voltage vs. Junction Temperature

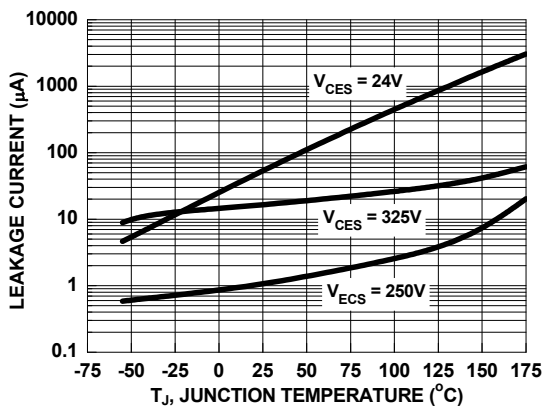

Figure 11. Leakage Current vs. Junction Temperature

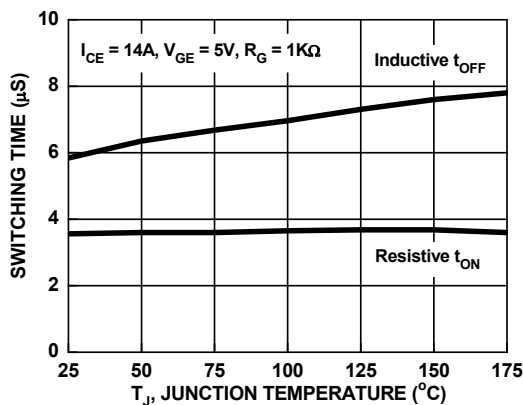

Figure 12. Switching Time vs. Junction Temperature

Typical Performance Curves (Continued)

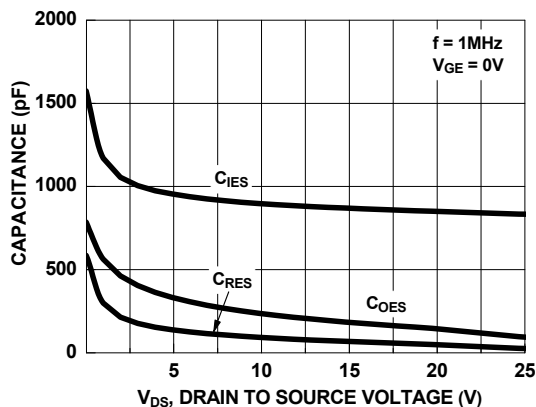

Figure 13. Capacitance vs. Collector to Emitter Voltage

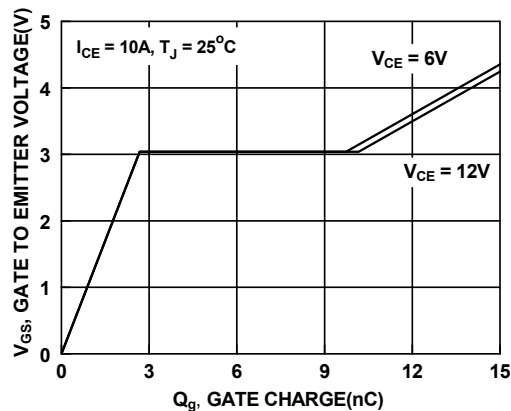

Figure 14. Gate Charge

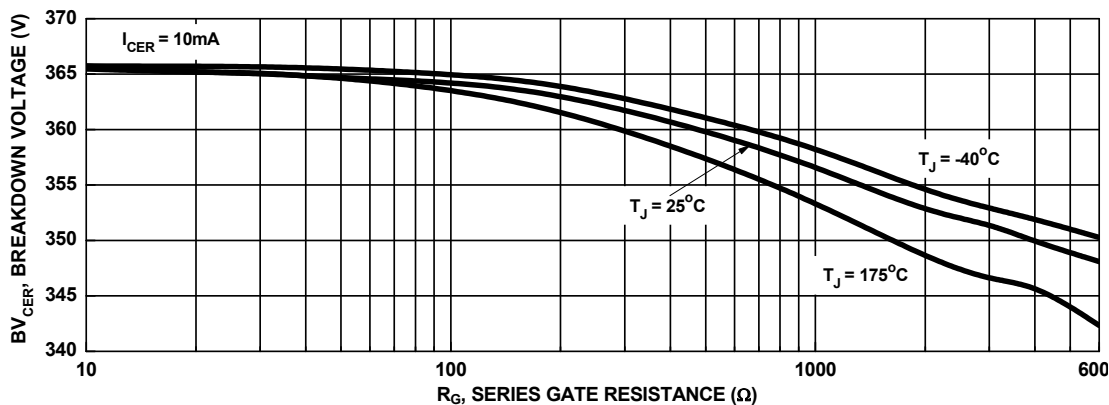

Figure 15. Break down Voltage vs. Series Gate Resistance

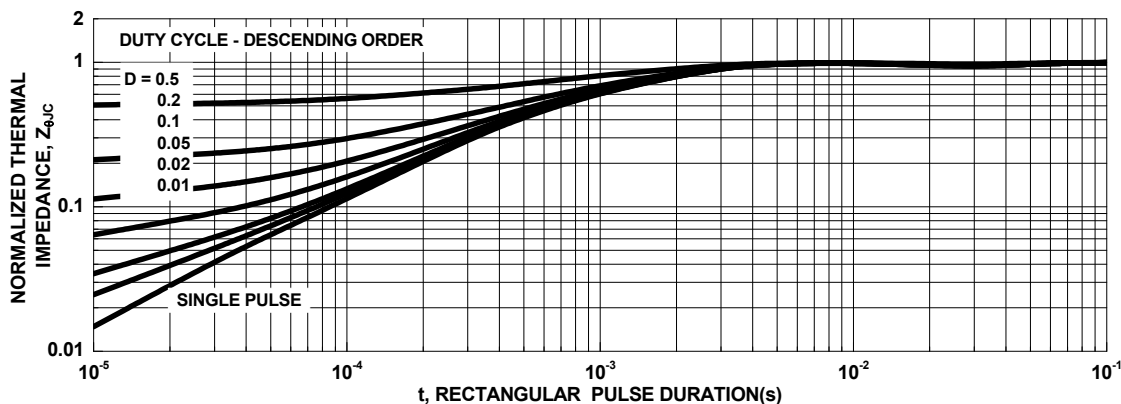

Figure 16. IGBT Normalized Transient Thermal Impedance, Junction to Case

# Typical Performance Curves

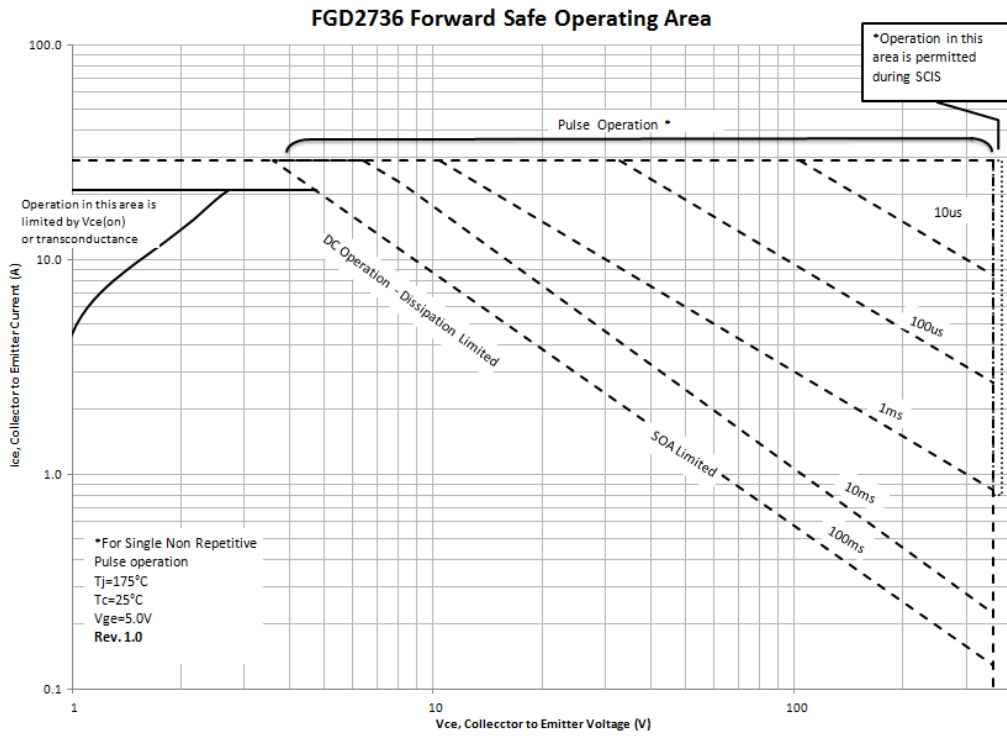
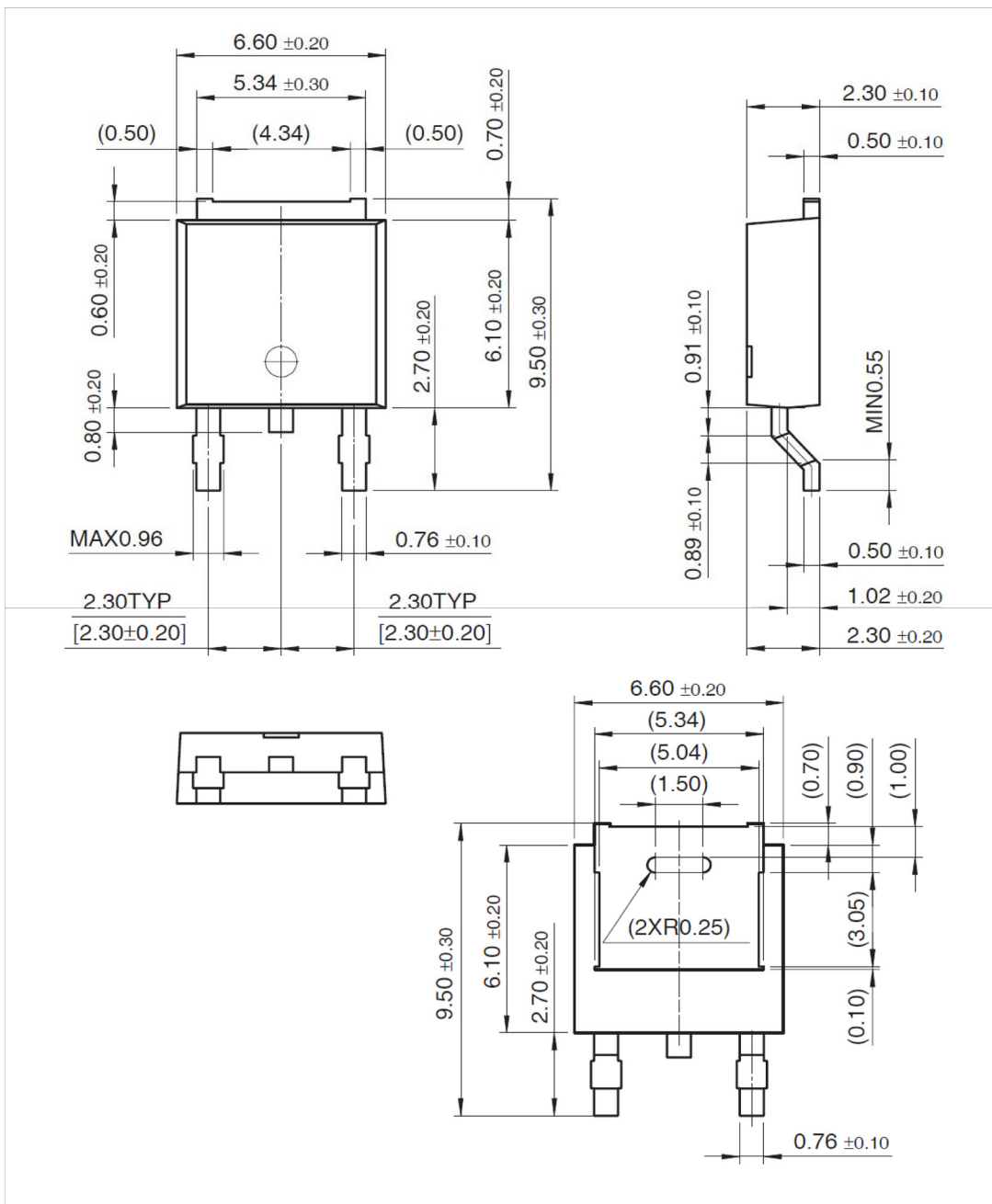

Figure 17. Forward Safe Operating Area

FGD2736G3-F085 EcoSPARK™ 270mJ, 360V, N-Channel Ignition IGBT

## Physical Dimensions



ON Semiconductor and  are trademarks of Semiconductor Components Industries, LLC dba ON Semiconductor or its subsidiaries in the United States and/or other countries. ON Semiconductor owns the rights to a number of patents, trademarks, copyrights, trade secrets, and other intellectual property. A listing of ON Semiconductor's product/patent coverage may be accessed at [www.onsemi.com/site/pdf/Patent-Marking.pdf](http://www.onsemi.com/site/pdf/Patent-Marking.pdf). ON Semiconductor reserves the right to make changes without further notice to any products herein. ON Semiconductor makes no warranty, representation or guarantee regarding the suitability of its products for any particular purpose, nor does ON Semiconductor assume any liability arising out of the application or use of any product or circuit, and specifically disclaims any and all liability, including without limitation special, consequential or incidental damages. Buyer is responsible for its products and applications using ON Semiconductor products, including compliance with all laws, regulations and safety requirements or standards, regardless of any support or applications information provided by ON Semiconductor. "Typical" parameters which may be provided in ON Semiconductor data sheets and/or specifications can and do vary in different applications and actual performance may vary over time. All operating parameters, including "Typicals" must be validated for each customer application by customer's technical experts. ON Semiconductor does not convey any license under its patent rights nor the rights of others. ON Semiconductor products are not designed, intended, or authorized for use as a critical component in life support systems or any FDA Class 3 medical devices or medical devices with a same or similar classification in a foreign jurisdiction or any devices intended for implantation in the human body. Should Buyer purchase or use ON Semiconductor products for any such unintended or unauthorized application, Buyer shall indemnify and hold ON Semiconductor and its officers, employees, subsidiaries, affiliates, and distributors harmless against all claims, costs, damages, and expenses, and reasonable attorney fees arising out of, directly or indirectly, any claim of personal injury or death associated with such unintended or unauthorized use, even if such claim alleges that ON Semiconductor was negligent regarding the design or manufacture of the part. ON Semiconductor is an Equal Opportunity/Affirmative Action Employer. This literature is subject to all applicable copyright laws and is not for resale in any manner.

## PUBLICATION ORDERING INFORMATION

### LITERATURE FULFILLMENT:

Literature Distribution Center for ON Semiconductor  
19521 E. 32nd Pkwy, Aurora, Colorado 80011 USA  
**Phone:** 303-675-2175 or 800-344-3860 Toll Free USA/Canada  
**Fax:** 303-675-2176 or 800-344-3867 Toll Free USA/Canada  
**Email:** [orderlit@onsemi.com](mailto:orderlit@onsemi.com)

**N. American Technical Support:** 800-282-9855 Toll Free  
USA/Canada  
**Europe, Middle East and Africa Technical Support:**  
Phone: 421 33 790 2910  
**Japan Customer Focus Center**  
Phone: 81-3-5817-1050

**ON Semiconductor Website:** [www.onsemi.com](http://www.onsemi.com)  
**Order Literature:** <http://www.onsemi.com/orderlit>  
For additional information, please contact your local  
Sales Representative



Компания «Life Electronics» занимается поставками электронных компонентов импортного и отечественного производства от производителей и со складов крупных дистрибьюторов Европы, Америки и Азии.

С конца 2013 года компания активно расширяет линейку поставок компонентов по направлению коаксиальный кабель, кварцевые генераторы и конденсаторы (керамические, пленочные, электролитические), за счёт заключения дистрибьюторских договоров

Мы предлагаем:

- Конкуренспособные цены и скидки постоянным клиентам.
- Специальные условия для постоянных клиентов.
- Подбор аналогов.
- Поставку компонентов в любых объемах, удовлетворяющих вашим потребностям.
- Приемлемые сроки поставки, возможна ускоренная поставка.
- Доставку товара в любую точку России и стран СНГ.
- Комплексную поставку.
- Работу по проектам и поставку образцов.
- Формирование склада под заказчика.
- Сертификаты соответствия на поставляемую продукцию (по желанию клиента).
- Тестирование поставляемой продукции.
- Поставку компонентов, требующих военную и космическую приемку.
- Входной контроль качества.
- Наличие сертификата ISO.

В составе нашей компании организован Конструкторский отдел, призванный помогать разработчикам, и инженерам.

Конструкторский отдел помогает осуществить:

- Регистрацию проекта у производителя компонентов.
- Техническую поддержку проекта.
- Защиту от снятия компонента с производства.
- Оценку стоимости проекта по компонентам.
- Изготовление тестовой платы монтаж и пусконаладочные работы.



Тел: +7 (812) 336 43 04 (многоканальный)

Email: [org@lifeelectronics.ru](mailto:org@lifeelectronics.ru)