

Features

- High Output Current Up to 1.5A
- Low Feedback Voltage:0.1V
- Stable with a Ceramic Output Capacitor
- Low Quiescent Current
- Open Load LED Protection
- Over Temperature Shutdown
- Low Temperature Coefficient
- Standard SOP-8(EP) Packages
- Pb-Free Package

Applications

- High Bright LED Driver
- White LED Torch (Flashlight)

General Description

The PAM2808 is a 5W high power HBLED driver with 1.5A constant current. It features high efficiency and low quiescent current, making it ideal for battery powered applications.

The PAM2808 features over current protection and over temperature shutdown. The PAM2808 is stable with a ceramic output capacitor of 4.7 μ F or higher.

PAM2808 is available in SOP-8(EP) package.

Typical Application Circuit

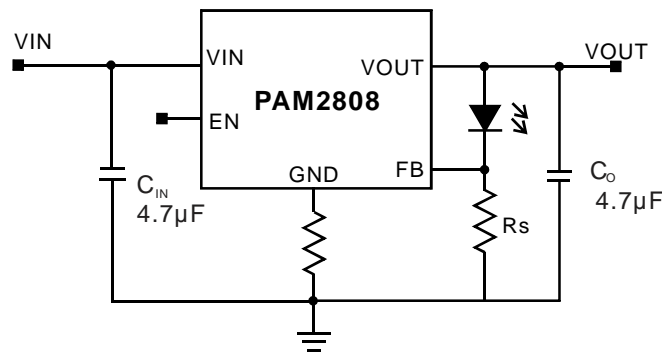

Block Diagram

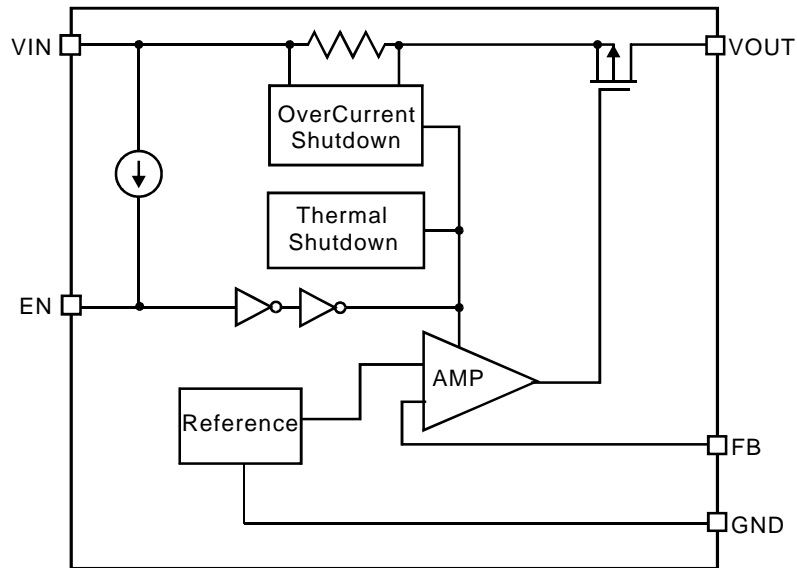

Pin Configuration & Marking Information

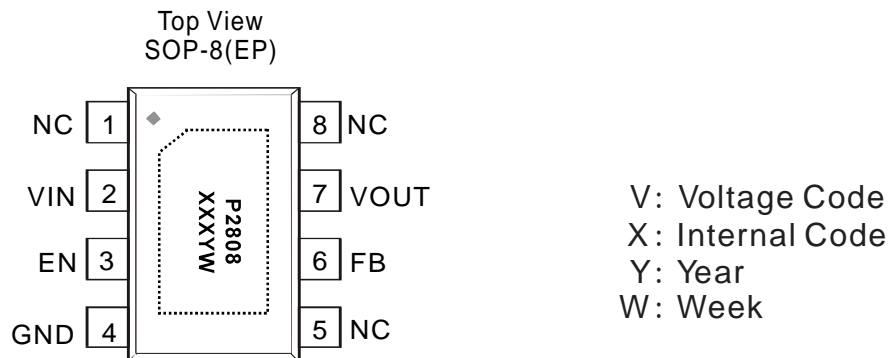



Absolute Maximum Ratings

These are stress ratings only and functional operation is not implied. Exposure to absolute maximum ratings for prolonged time periods may affect device reliability. All voltages are with respect to ground.

| | |
|--|--|
| Input Voltage.....6.5V | Storage Temperature.....-65°C to 150°C |
| EN, FB, VOUT Pin Voltage | Maximum Junction Temperature.....150°C |
|-0.3V to $V_{IN}+0.3V$ | Lead Soldering Temperature (5sec)..... 300°C |
| Maximum Output Current..... $P_D/(V_{IN}-V_O)$ | |

Recommended Operating Conditions

| | |
|-------------------------------|---|
| Maximum Supply Voltage.....6V | Junction Temperature Range.....-40°C to 125°C |
| | Ambient Temperature Range.....-40°C to 85°C |

Thermal Information

| Parameter | Symbol | Package | Maximum | Unit |
|---|---------------|-----------|---------|------|
| Thermal Resistance (Junction to Case) | θ_{JC} | SOP-8(EP) | 11 | °C/W |
| Thermal Resistance (Junction to Ambient) | θ_{JA} | SOP-8(EP) | 90 | °C/W |



Electrical Characteristic

$V_{IN}=4.5V, T_A=25^{\circ}C, C_{IN}=4.7\mu F, C_O=4.7\mu F$, unless otherwise noted.

| PARAMETER | SYMBOL | Test Conditions | MIN | TYP | MAX | UNITS |
|-----------------------------|-----------|---------------------|-----|------|-----|-------------|
| Input Voltage | V_{IN} | | 2.5 | | 6.0 | V |
| FB Reference Voltage | V_{REF} | | | 0.1 | | V |
| Output Current | I_O | $R_S=0.3\Omega$ | | 330 | | mA |
| | | $R_S=0.14\Omega$ | | 700 | | |
| | | $R_S=0.1\Omega$ | | 1000 | | |
| | | $R_S=0.067\Omega$ | | 1500 | | |
| Over Temperature Shutdown | OTS | | | 150 | | $^{\circ}C$ |
| Over Temperature Hysteresis | OTH | | | 40 | | $^{\circ}C$ |
| EN Input High Threshold | V_{EH} | $V_{IN}=2.5V$ to 5V | 1.5 | | | V |
| EN Input Low Threshold | V_{EL} | $V_{IN}=2.5V$ to 5V | | | 0.3 | V |
| Shutdown Current | I_{SD} | $V_{EN}=0V$ | | | 1 | μA |

Typical Performance Characteristics

$T_A=25^{\circ}\text{C}$, $C_{IN}=4.7\mu\text{F}$, $C_O=4.7\mu\text{F}$, unless otherwise noted.

1. LED Current vs Input Voltage

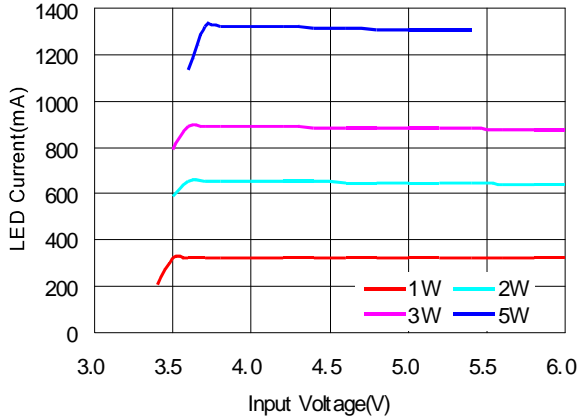

2. Feedback Voltage vs Input Voltage

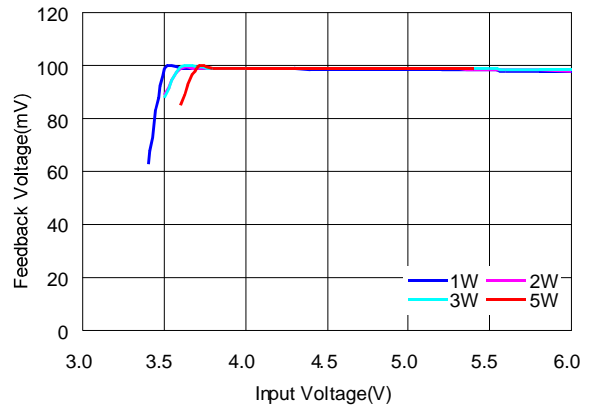

3. Dropout Voltage vs LED Current

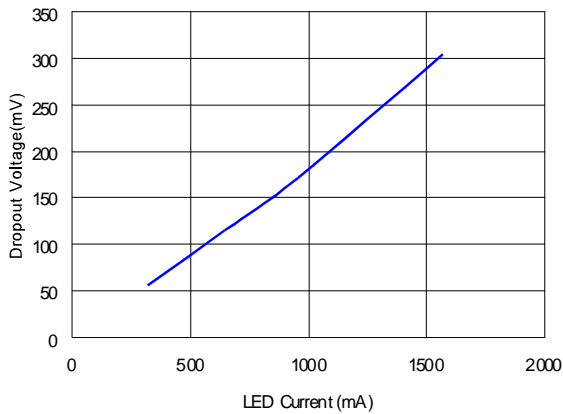

4. Start up

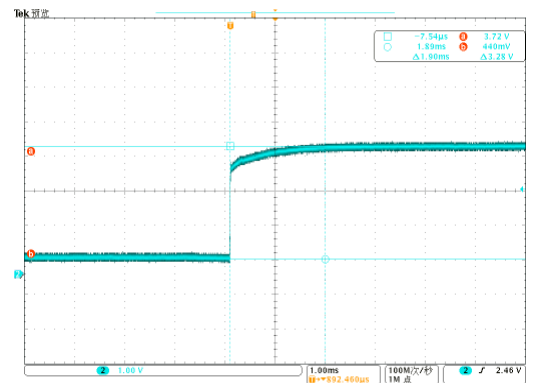

Application Information

External Capacitor Requirements

A 4.7µF or larger ceramic input bypass capacitor, connected between V_{IN} and GND and located close to the PAM2808, is required for stability. A 4.7µF minimum value capacitor from V_O to GND is also required. To improve transient response, noise rejection, and ripple rejection, an additional 10µF or larger, low ESR capacitor is recommended at the output. A higher-value, low ESR output capacitor may be necessary if large, fast-rise-time load transients are anticipated and the device is located several inches from the power source, especially if the minimum input voltage of 2.5 V is used.

Regulator Protection

The PAM2808 features internal current limiting, thermal protection and short circuit protection. During normal operation, the PAM2808 limits output current to about 2.5A. When current limiting engages, the output voltage scales back linearly until the over current condition ends. While current limiting is designed to prevent gross device failure, care should be taken not to exceed the power dissipation ratings of the package. If the temperature of the device exceeds 150°C, thermal-protection circuitry will shut down. Once the device has cooled down to approximately 40°C below the high temp trip point, regulator operation resumes.

Thermal Information

The amount of heat generates is:

$$P_D = (V_{IN} - V_O) I_O$$

All integrated circuits have a maximum allowable junction temperature (T_J max) above which normal operation is not assured. A system designer must design the operating environment so that the operating junction temperature (T_J) does not exceed the maximum junction temperature (T_J max). The two main environmental variables that a designer can use to improve thermal performance are air flow and external heatsinks. The purpose of this information is to aid the designer in determining the proper operating environment for a linear regulator that is operating at a specific power level.

In general, the maximum expected power ($P_D(\max)$) consumed by a linear regulator is computed as:

$$P_{D\max} = (V_{I(\text{avg})} - V_{O(\text{avg})}) \times I_{O(\text{avg})} + V_{I(\text{avg})} \times I_{(Q)}$$

Where:

- $V_{I(\text{avg})}$ is the average input voltage.
- $V_{O(\text{avg})}$ is the average output voltage.
- $I_{O(\text{avg})}$ is the average output current.
- $I_{(Q)}$ is the quiescent current.

The quiescent current is insignificant compared to the average output current; therefore, the term $V_{I(\text{avg})} \times I_{(Q)}$ can be neglected. The operating junction temperature is computed by adding the ambient temperature (T_A) and the increase in temperature due to the regulator's power dissipation. The temperature rise is computed by multiplying the maximum expected power dissipation by the sum of the thermal resistances between the junction and the case ($R_{\theta JC}$), the case to heatsink ($R_{\theta CS}$), and the heatsink to ambient ($R_{\theta SA}$). Thermal resistances are measures of how effectively an object dissipates heat. Typically, the larger the device, the more surface area available for power dissipation so that the object's thermal resistance will be lower.

Ordering Information

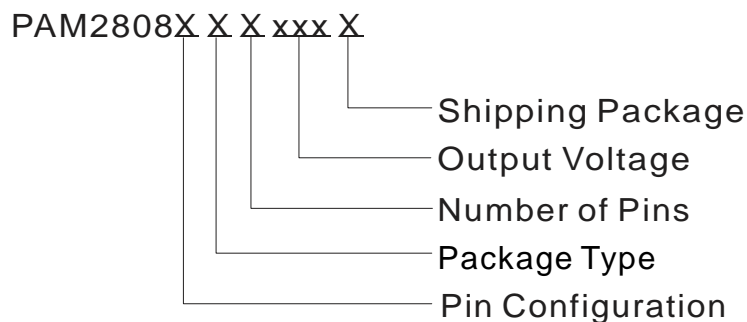

| Pin Configuration | Package Type | Number of Pins | Shipping Package |
|---|--------------|----------------|------------------|
| B Type: 1. NC 2. VIN 3. EN 4. GND 5. NC 6. FB 7. VOUT 8. NC | L: SOP-8(EP) | B: 8 | R: Tape & Reel |

| Part Number | Marking | Package Type | MOQ & Shipping Pckage |
|-------------|----------------|--------------|--------------------------|
| PAM2808BLBR | P2808 XXXYW | SOP-8(EP) | 2,500 Units/Tapes & Reel |

Outline Dimensions

SOP-8(EP)

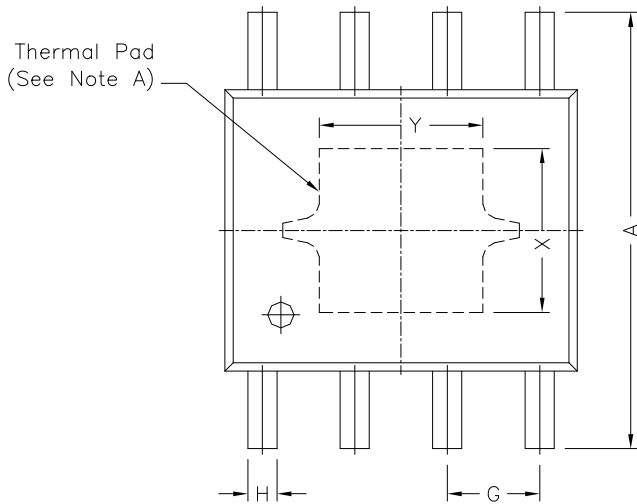

| REF. | DIMENSIONS | |
|---------|-------------|------|
| | Millimeters | |
| | Min. | Max. |
| A | 5.80 | 6.20 |
| B | 4.80 | 5.00 |
| C | 3.80 | 4.00 |
| D | 0° | 8° |
| E | 0.40 | 0.90 |
| F | 0.19 | 0.25 |
| M | 0 | 0.15 |
| H | 0.35 | 0.49 |
| L | 1.35 | 1.75 |
| G | 1.27 TYP. | |
| Option1 | X | 2.28 |
| | Y | 2.28 |
| Option2 | X | 2.41 |
| | Y | 3.30 |

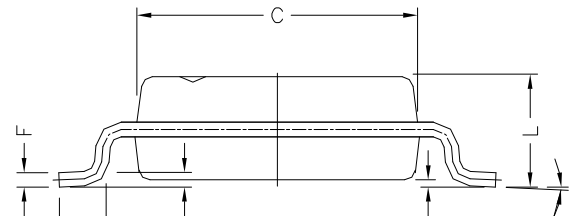
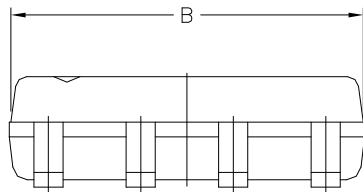

Компания «Life Electronics» занимается поставками электронных компонентов импортного и отечественного производства от производителей и со складов крупных дистрибьюторов Европы, Америки и Азии.

С конца 2013 года компания активно расширяет линейку поставок компонентов по направлению коаксиальный кабель, кварцевые генераторы и конденсаторы (керамические, пленочные, электролитические), за счёт заключения дистрибьюторских договоров

Мы предлагаем:

- Конкуренеспособные цены и скидки постоянным клиентам.
- Специальные условия для постоянных клиентов.
- Подбор аналогов.
- Поставку компонентов в любых объемах, удовлетворяющих вашим потребностям.
- Приемлемые сроки поставки, возможна ускоренная поставка.
- Доставку товара в любую точку России и стран СНГ.
- Комплексную поставку.
- Работу по проектам и поставку образцов.
- Формирование склада под заказчика.
- Сертификаты соответствия на поставляемую продукцию (по желанию клиента).
- Тестирование поставляемой продукции.
- Поставку компонентов, требующих военную и космическую приемку.
- Входной контроль качества.
- Наличие сертификата ISO.

В составе нашей компании организован Конструкторский отдел, призванный помогать разработчикам, и инженерам.

Конструкторский отдел помогает осуществить:

- Регистрацию проекта у производителя компонентов.
- Техническую поддержку проекта.
- Защиту от снятия компонента с производства.
- Оценку стоимости проекта по компонентам.
- Изготовление тестовой платы монтаж и пусконаладочные работы.



Тел: +7 (812) 336 43 04 (многоканальный)

Email: org@lifeelectronics.ru