

IRS20957S Protected Digital Audio Driver

Features

- Floating PWM input enables easy half bridge implementation
- Programmable bidirectional over-current protection with self-reset function
- Programmable preset dead-time for improved THD performances
- High noise immunity
- $\pm 100V$ ratings deliver up to 500W in output power
- 3.3 V/ 5 V logic compatible input
- Operates up to 800kHz

Typical Applications

- Home theatre systems
- Mini component stereo systems
- Powered speaker systems
- General purpose audio power amplifiers

Product Summary

Topology	Half-Bridge
$V_{\text{OFFSET (max)}}$	+/- 100 V
I_{O+} & I_{O-} (typical)	1.0 A & 1.2 A
Selectable deadtime	15/25/35/80ns
Ton & toff (typical)	95ns & 80ns
OC protection delay	500ns (max)
Shutdown propagation delay	250ns (max)

Package



Typical Connection Diagram

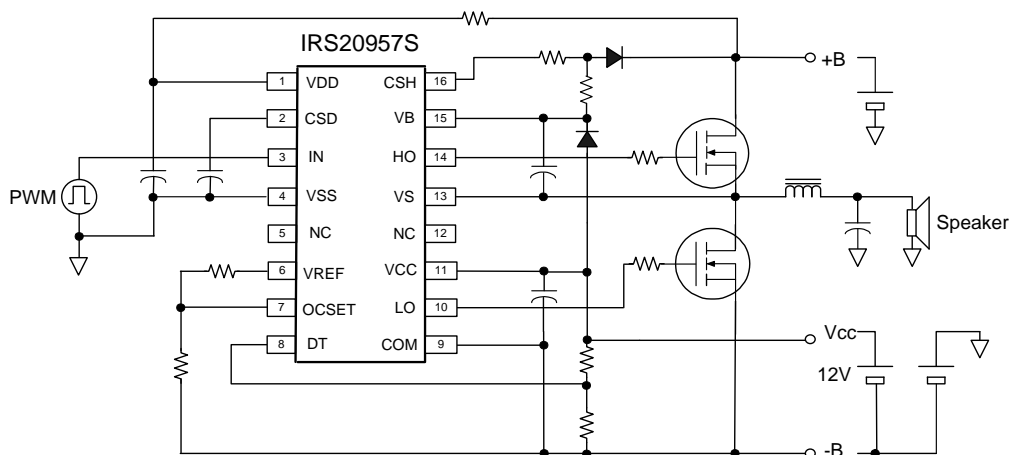

Note: Please refer to Lead Assignments for correct pin configuration. This diagram shows electrical connections only.

Table of Contents	Page
Description	3
Qualification Information	4
Absolute Maximum Ratings	5
Recommended Operating Conditions	6
Electrical Characteristics	7
Functional Block Diagram	9
Input/Output Pin Equivalent Circuit Diagram	10
Lead Definitions	11
Lead Assignments	11
Waveform definitions	12
Application information and additional information	12
Package Details	13
Tape and Reel Details	14
Part Marking Information	15
Ordering Information	16

Description

The IRS20957S is a high voltage, high speed MOSFET driver with a floating PWM input designed for Class D audio amplifier applications.

Bi-directional current sensing detects over current conditions during positive and negative load currents without any external shunt resistors. A built-in protection control block provides a secure protection sequence against over-current conditions and a programmable reset timer.

The internal dead-time generation block enables accurate gate switching and optimum dead-time setting for better audio performance, such as lower THD and lower audio noise floor.

Qualification Information[†]

Qualification Level		Industrial ^{††}	
		Comments: This family of ICs has passed JEDEC's Industrial qualification. IR's Consumer qualification level is granted by extension of the higher Industrial level.	
Moisture Sensitivity Level		SOIC16N	MSL2 ^{†††} 260°C (per IPC/JEDEC J-STD-020)
ESD	Machine Model	Class B (per JEDEC standard EIA/JESD22-A115)	
	Human Body Model	Class 2 (per EIA/JEDEC standard JESD22-A114)	
IC Latch-Up Test		Class I , Level A (per JESD78)	
RoHS Compliant		Yes	

† Qualification standards can be found at International Rectifier's web site <http://www.irf.com/>

†† Higher qualification ratings may be available should the user have such requirements. Please contact your International Rectifier sales representative for further information.

††† Higher MSL ratings may be available for the specific package types listed here. Please contact your International Rectifier sales representative for further information.

Absolute Maximum Ratings

Absolute Maximum Ratings indicate sustained limits beyond which damage to the device may occur. All voltage parameters are absolute voltages referenced to COM; all currents are defined positive into any lead. The Thermal Resistance and Power Dissipation ratings are measured under board mounted and still air conditions.

Symbol	Definition	Min.	Max.	Units
V _B	High side floating supply voltage	-0.3	215	V
V _S	High side floating supply voltage [†]	V _B -15	V _B +0.3	
V _{HO}	High side floating output voltage	V _S -0.3	V _B +0.3	
V _{CSH}	CSH pin input voltage	V _S -0.3	V _B +0.3	
V _{CC}	Low side fixed supply voltage [†]	-0.3	20	
V _{LO}	Low side output voltage	-0.3	V _{CC} +0.3	
V _{DD}	Floating input supply voltage	-0.3	210	
V _{SS}	Floating input supply voltage [†]	(See I _{DDZ})	V _{DD} +0.3	
V _{IN}	PWM input voltage	V _{SS} -0.3	V _{DD} +0.3	
V _{CSD}	CSD pin input voltage	V _{SS} -0.3	V _{DD} +0.3	
V _{DT}	DT pin input voltage	-0.3	V _{CC} +0.3	
V _{OCSET}	OCSET pin input voltage	-0.3	V _{CC} +0.3	
V _{REF}	VREF pin voltage	-0.3	V _{CC} +0.3	
I _{DDZ}	Floating input supply zener clamp current [†]	-	10	
I _{CCZ}	Low side supply zener clamp current [†]	-	10	
I _{BSZ}	Floating supply zener clamp current [†]	-	10	
I _{OREF}	Reference output current	-	5	
d V _S /dt	Allowable V _S voltage slew rate	-	50	V/ns
d V _{SS} /dt	Allowable V _{SS} voltage slew rate ^{††}	-	50	
d V _{SS} /dt	Allowable V _{SS} voltage slew rate upon power-up ^{†††}	-	50	V/ms
P _d	Maximum power dissipation	-	1.0	W
R _{thJA}	Thermal resistance, Junction to ambient	-	115	°C/W
T _J	Junction Temperature	-	150	°C
T _S	Storage Temperature	-55	150	
T _L	Lead temperature (Soldering, 10 seconds)	-	300	

† V_{DD} - V_{SS}, V_{CC} -COM and V_B - V_S contain internal shunt zener diodes. Please note that the voltage ratings of these can be limited by the clamping current.

†† For the rising and falling edges of step signal of 10V. V_{SS}=15V to 200V.

††† V_{SS} ramps up from 0V to 200V.

Recommended Operating Conditions

For proper operation, the device should be used within the recommended conditions below. The V_S and COM offset ratings are tested with supplies biased at $I_{DD}=5mA$, $V_{CC}=12V$ and $V_B-V_S=12V$.

Symbol	Definition	Min.	Max.	Units
V_B	High side floating supply absolute voltage	V_S+10	V_S+14	V
V_S	High side floating supply offset voltage	†	200	
I_{DDZ}	Floating input supply zener clamp current	1	5	mA
V_{SS}	Floating input supply absolute voltage	0	100	V
V_{HO}	High side floating output voltage	V_S	V_B	
V_{CC}	Low side fixed supply voltage	10	15	
V_{LO}	Low side output voltage	0	V_{CC}	
V_{IN}	PWM input voltage	V_{SS}	V_{DD}	
V_{CSD}	CSD pin input voltage	V_{SS}	V_{DD}	
V_{DT}	DT pin input voltage	0	V_{CC}	
I_{OREF}	Reference output current to COM†	0.3	0.8	mA
V_{OCSET}	OCSET pin input voltage	0.5	5	V
T_A	Ambient Temperature	-40	125	°C

† Logic operational for V_S equal to $-5V$ to $+200V$. Logic state held for V_S equal to $-5V$ to $-V_{BS}$.

†† Nominal voltage for V_{REF} is $5V$. I_{OREF} of $0.3 - 0.8mA$ dictates total external resistor value on V_{REF} to be $6.3k$ to $16.7k \Omega$.

Electrical Characteristics

$V_{CC}, V_{BS} = 12\text{ V}$, $I_{DD} = 5\text{ mA}$, $V_{SS} = 20\text{ V}$, $V_S = 0\text{ V}$, $C_L = 1\text{ nF}$ and $T_A = 25^\circ\text{C}$ unless otherwise specified.

Symbol	Description	Min	Typ	Max	Units	Test Conditions
Low Side Supply						
UV_{CC+}	V_{CC} supply UVLO positive threshold	8.4	8.9	9.4	V	
UV_{CC-}	V_{CC} supply UVLO negative threshold	8.2	8.7	9.2		
I_{QCC}	Low side quiescent current	-	-	3	mA	$V_{DT} = V_{CC}$
V_{CLAMPL}	Low side zener diode clamp voltage	19.6	20.4	21.6	V	$I_{CC} = 5\text{ mA}$
High Side Floating Supply						
UV_{BS+}	High side well UVLO positive threshold	8.0	8.5	9.0	V	
UV_{BS-}	High side well UVLO negative threshold	7.8	8.3	8.8		
I_{QBS}	High side quiescent current	-	-	1	mA	
I_{LKH}	High to Low side leakage current	-	-	50	μA	$V_B = V_S = 200\text{ V}$
V_{CLAMPH}	High side zener diode clamp voltage	14.7	15.3	16.2	V	$I_{BS} = 5\text{ mA}$
Floating Input Supply						
UV_{DD+}	V_{DD}, V_{SS} floating supply UVLO positive threshold	8.2	8.7	9.2	V	$V_{SS} = 0\text{ V}$
UV_{DD-}	V_{DD}, V_{SS} floating supply UVLO negative threshold	7.7	8.2	8.7		$V_{SS} = 0\text{ V}$
I_{QDD}	Floating Input quiescent current	-	-	1	mA	$V_{DD} = 9.5\text{ V} + V_{SS}$
V_{CLAMPM}	Floating Input zener diode clamp voltage	9.8	10.2	10.8	V	$I_{DD} = 5\text{ mA}$
I_{LKM}	Floating input side to Low side leakage current	-	-	50	μA	$V_{DD} = V_{SS} = 200\text{ V}$
Floating PWM Input						
V_{IH}	Logic high input threshold voltage	2.3	1.9	-	V	
V_{IL}	Logic low input threshold voltage	-	1.9	1.5		
I_{IN+}	Logic "1" input bias current	-	-	40	μA	$V_{IN} = 3.3\text{ V}$
I_{IN-}	Logic "0" input bias current	-	-	1		$V_{IN} = V_{SS}$
Protection						
V_{REF}	Reference output voltage	4.8	5.1	5.4	V	$I_{OREF} = 0.5\text{ mA}$
V_{thOCL}	Low side OC threshold in V_S	1.1	1.2	1.3		OCSET=1.2V, Figure 3
V_{thOCH}	High side OC threshold in V_{CSH}	$1.1 + V_S$	$1.2 + V_S$	$1.3 + V_S$		$V_S = 200\text{ V}$, Figure 4
V_{th1}	CSD pin shutdown release threshold	$0.62 \times V_{DD}$	$0.70 \times V_{DD}$	$0.78 \times V_{DD}$		$V_{SS} = 0\text{ V}$
V_{th2}	CSD pin self reset threshold	$0.26 \times V_{DD}$	$0.30 \times V_{DD}$	$0.34 \times V_{DD}$		$V_{SS} = 0\text{ V}$
I_{CSD+}	CSD pin discharge current	70	100	130	μA	$V_{SD} = V_{SS} + 5\text{ V}$
I_{CSD-}	CSD pin charge current	70	100	130		$V_{SD} = V_{SS} + 5\text{ V}$

Protection (continued)							
Symbol	Description	Min	Typ	Max	Units	Test Conditions	
t_{SD}	Shutdown propagation delay from $V_{CSD} > V_{SS} + V_{th_{OCH}}$ to Shutdown	-	-	250	ns	Figure 2	
t_{OCH}	Propagation delay time from $V_{C_{SH}} > V_{th_{OCH}}$ to Shutdown	-	-	500		Figure 4	
t_{OCL}	Propagation delay time from $V_S > V_{th_{OCL}}$ to Shutdown	-	-	500		Figure 3	
Gate Driver							
I_{o+}	Output high short circuit current (Source)	-	1.0	-	A	$V_o=0V$, $PW \leq 10\mu S$	
I_{o-}	Output low short circuit current (Sink)	-	1.2	-		$V_o=12V$, $PW \leq 10\mu S$	
V_{OL}	Low level out put voltage LO – COM, HO – VS	-	-	0.1	V	$I_o=0A$	
V_{OH}	High level out put voltage VCC – LO, VB – HO	-	-	1.4		$I_o=0A$	
t_r	Turn-on rise time	-	15	-	ns		
t_f	Turn-off fall time	-	10	-			
Ton_1	High and low side turn-on propagation delay, floating inputs	-	95	-		$V_{DT} = V_{CC}$, $V_S = 100V$, $V_{SS} = 100V$	
Toff_1	High and low side turn-off propagation delay, floating inputs	-	80	-		$V_{DT} = V_{CC}$, $V_S = 100V$, $V_{SS} = 100V$	
Ton_2	High and low side turn-on propagation delay, non-floating inputs	-	95	-		$V_{DT} = V_{CC}$, $V_S = 100V$, $V_{SS} = COM$	
Toff_2	High and low side turn-off propagation delay, non-floating inputs	-	80	-		$V_{DT} = V_{CC}$, $V_S = 100V$, $V_{SS} = COM$	
DT1	Deadtime: LO turn-off to HO turn-on (DT_{LO-HO}) & HO turn-off to LO turn-on (DT_{HO-LO})	8	15	22		$V_{DT} > V_{DT1}$, $V_{SS} = COM$	
DT2	Deadtime: LO turn-off to HO turn-on (DT_{LO-HO}) & HO turn-off to LO turn-on (DT_{HO-LO})	15	25	35		$V_{DT1} > V_{DT} > V_{DT2}$, $V_{SS} = COM$	
DT3	Deadtime: LO turn-off to HO turn-on (DT_{LO-HO}) & HO turn-off to LO turn-on (DT_{HO-LO})	20	35	50		$V_{DT2} > V_{DT} > V_{DT3}$, $V_{SS} = COM$	
DT4	Deadtime: LO turn-off to HO turn-on (DT_{LO-HO}) & HO turn-off to LO turn-on (DT_{HO-LO}) $V_{DT} = V_{DT4}$	50	80	110		$V_{DT3} > V_{DT}$, $V_{SS} = COM$	
V_{DT1}	DT mode select threshold 1	$0.51 \times V_{CC}$	$0.57 \times V_{CC}$	$0.63 \times V_{CC}$		V	
V_{DT2}	DT mode select threshold 2	$0.32 \times V_{CC}$	$0.36 \times V_{CC}$	$0.40 \times V_{CC}$			
V_{DT3}	DT mode select threshold 3	$0.21 \times V_{CC}$	$0.23 \times V_{CC}$	$0.25 \times V_{CC}$			

Functional Block Diagram

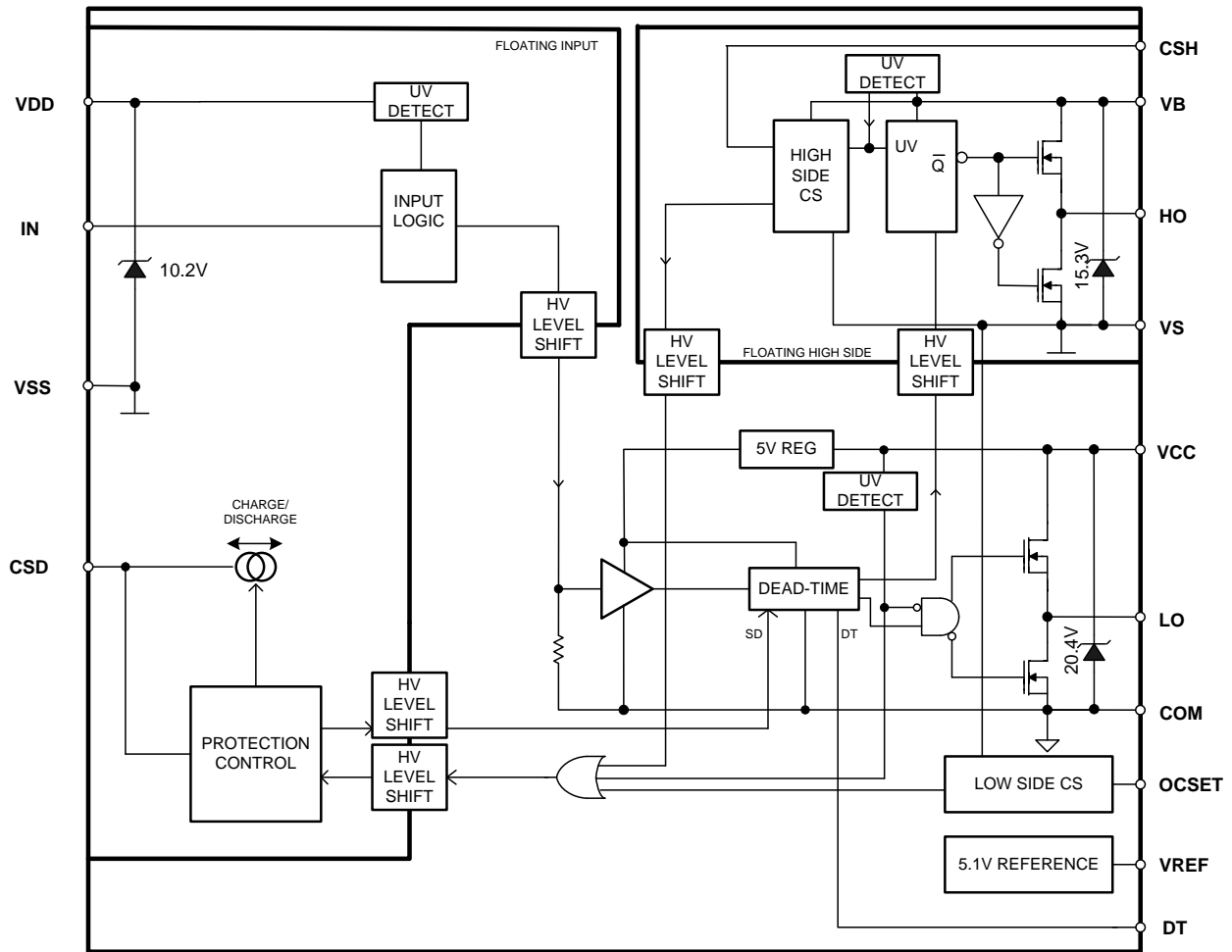

I/O Pin Equivalent Circuit Diagrams

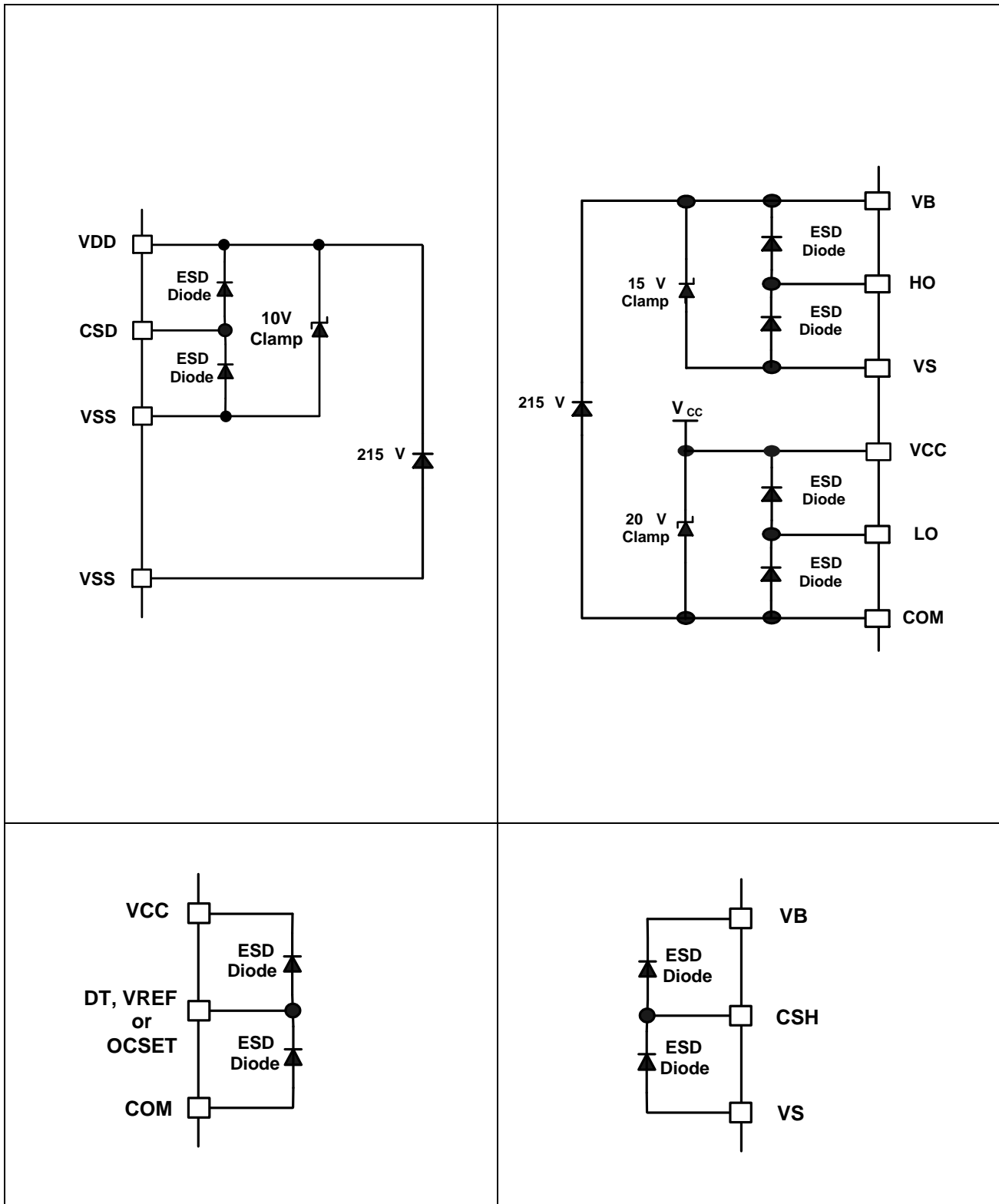

Lead Definitions

Pin #	Symbol	Description
1	VDD	Floating input positive supply
2	CSD	Shutdown timing capacitor, referenced to VSS
3	IN	PWM non-inverting input, in phase with HO
4	VSS	Floating input supply return
5	NC	
6	VREF	5V reference output for setting OCSET
7	OCSET	Low side over current threshold setting, referenced to COM
8	DT	Input for programmable dead-time, referenced to COM
9	COM	Low side supply return
10	LO	Low side output
11	VCC	Low side logic supply
12	NC	
13	VS	High side floating supply return
14	HO	High side output
15	VB	High side floating supply
16	CSH	High side over current sensing input, referenced to VS

Lead Assignments

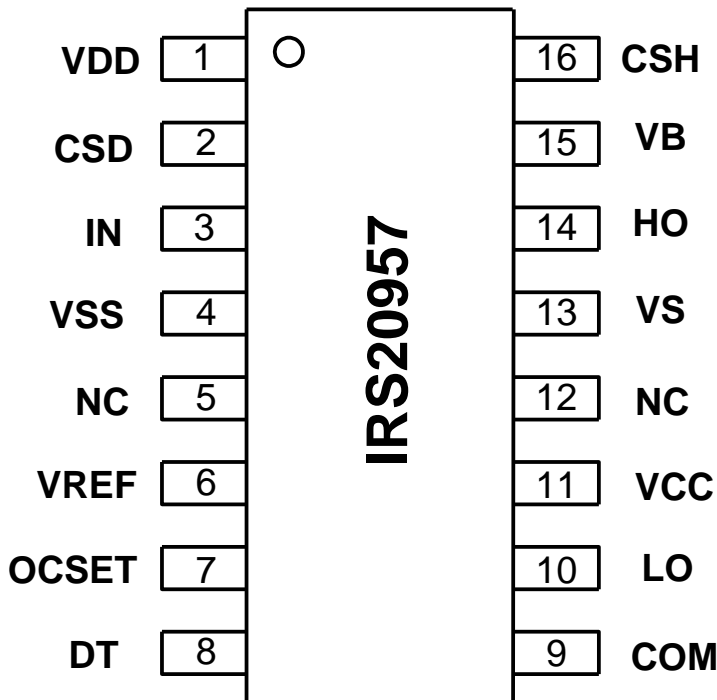

Waveform definitions

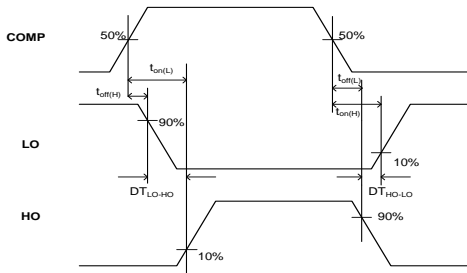

Figure 1: Switching Time Waveform Definitions

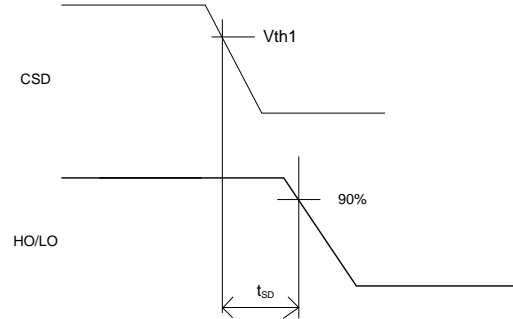

Figure 2: CSD to Shutdown Waveform Definitions

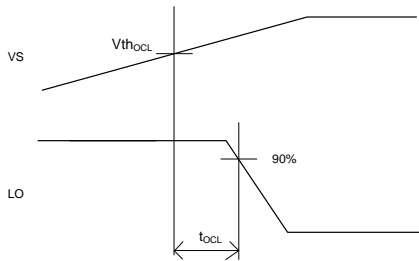

Figure 3: $V_S > V_{th_{OCL}}$ to Shutdown Waveform

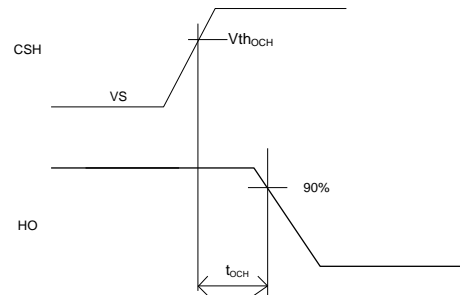
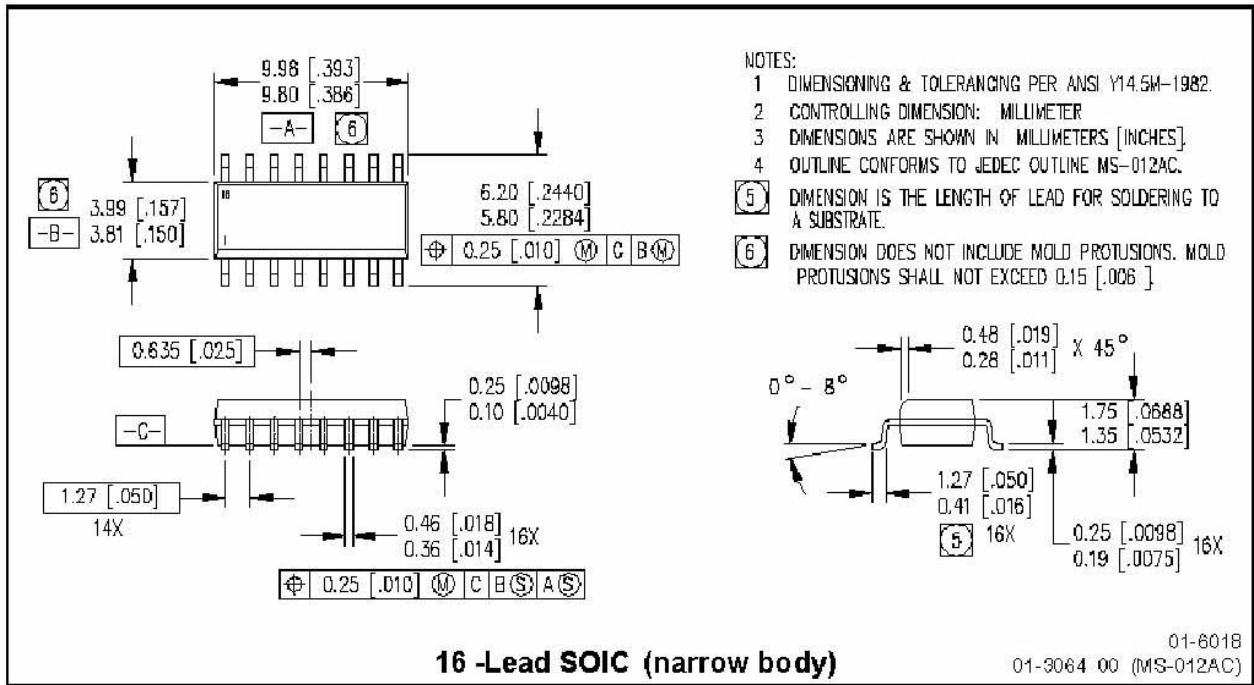

Figure 4: $V_{CSH} > V_{th_{OCH}}$ to Shutdown Waveform

Application information and additional information

Please refer to AN-1144 for IRS20957 functional description.

Package Details: SOIC16N



Package Details: SOIC16N, Tape and Reel

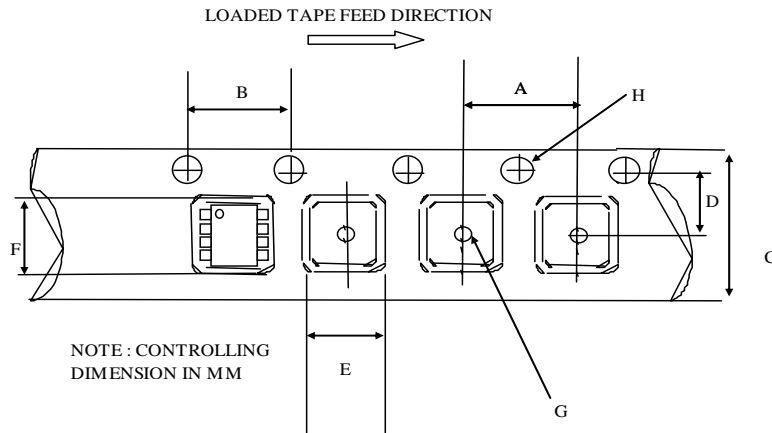

CARRIER TAPE DIMENSION FOR 16SOICN

Code	Metric		Imperial	
	Min	Max	Min	Max
A	7.90	8.10	0.311	0.318
B	3.90	4.10	0.153	0.161
C	15.70	16.30	0.618	0.641
D	7.40	7.60	0.291	0.299
E	6.40	6.60	0.252	0.260
F	10.20	10.40	0.402	0.409
G	1.50	n/a	0.059	n/a
H	1.50	1.60	0.059	0.062

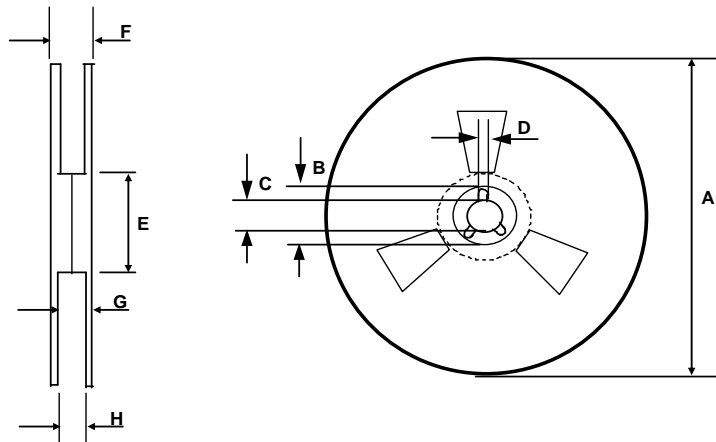

REEL DIMENSIONS FOR 16SOICN

Code	Metric		Imperial	
	Min	Max	Min	Max
A	329.60	330.25	12.976	13.001
B	20.95	21.45	0.824	0.844
C	12.80	13.20	0.503	0.519
D	1.95	2.45	0.767	0.096
E	98.00	102.00	3.858	4.015
F	n/a	22.40	n/a	0.881
G	18.50	21.10	0.728	0.830
H	16.40	18.40	0.645	0.724

Part Marking Information

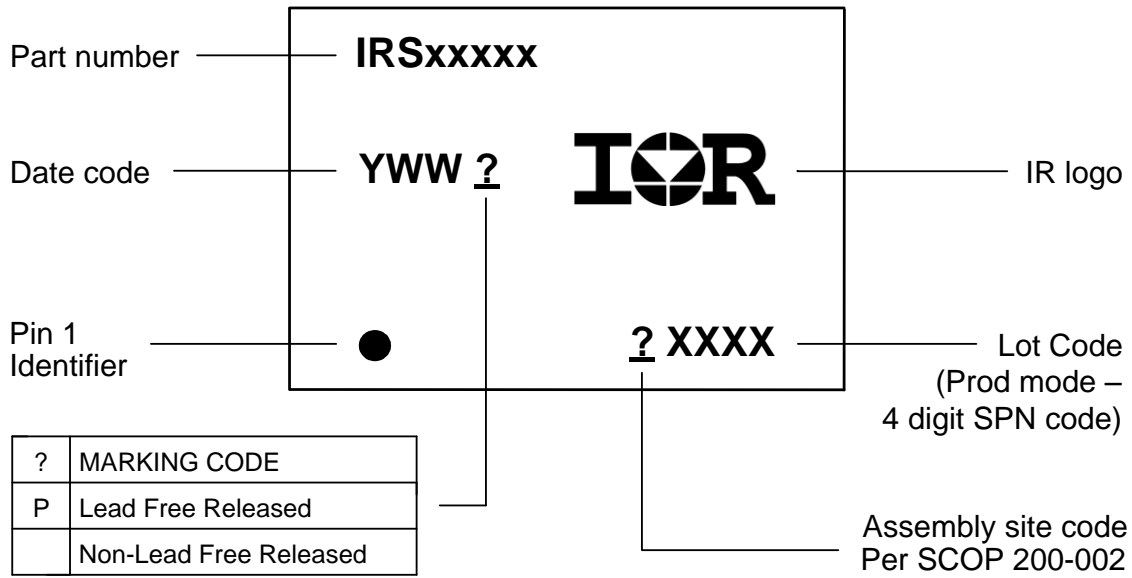

Ordering Information

Base Part Number	Package Type	Standard Pack		Complete Part Number
		Form	Quantity	
IRS20957S	SOIC16N	Tube/Bulk	45	IRS20957SPBF
		Tape and Reel	2500	IRS20957STRPBF

The information provided in this document is believed to be accurate and reliable. However, International Rectifier assumes no responsibility for the consequences of the use of this information. International Rectifier assumes no responsibility for any infringement of patents or of other rights of third parties which may result from the use of this information. No license is granted by implication or otherwise under any patent or patent rights of International Rectifier. The specifications mentioned in this document are subject to change without notice. This document supersedes and replaces all information previously supplied.

For technical support, please contact IR's Technical Assistance Center

<http://www.irf.com/technical-info/>

WORLD HEADQUARTERS:

233 Kansas St., El Segundo, California 90245

Tel: (310) 252-7105

Change History

March 14, 2008

- 1) Updated the format
- 2) Added Product Summary
- 3) Added Qualification table

March 18, 2008

- 1) Added package details, part marking, ordering info

April 22, 2008

- 1) Inserted ton, toff typical numbers
- 2) Removed unnecessary place holders
- 3) Inserted I/O dwgs
- 4) Fixed formatting on tables
- 5) Changed copyright to 2008 instead of 2007
- 6) Added waveform definition section based on IRS20954/5 DS

April 23, 2008

- 1) Changed topology to HBridge
- 2) Changed ton typical to 95ns (on product summary table and elec. Char. Table)

April 24, 2008

- 1) Changed Typical Connection Diagram
- 2) Changed High side zener diode clamp voltage
- 3) Changed I/O Pin Equivalent Circuit Diagrams

Absolute Maximum Ratings

V_B	High side floating supply voltage	-0.3	215	V
V_S	High side floating supply voltage (Note1)	V_B-15	$V_B+0.3$	V

Recommended Operating Conditions

V_B	High side floating supply absolute voltage	V_S+10	V_S+14	V
V_{CC}	Low side fixed supply voltage	10	15	V

April 29, 2008

- 1) Changed format
- 2) Changed "note1, 2, 3" to "†, ††, †††"

June 12, 08

- 1) Replaced part marking information with the latest version

June 23, 08

- 1) Updated std pack quantity for SO16N to 45 pcs

August 4th, 2008:

- 1) added typical applications on page 1
- 2) removed PbF from product name on page 1
- 3) Merge units in table
- 4) Added "Application information and additional details" on page 12.

September 10th, 2008

1) Added AN-1144 on page 12

March 5, 2009

Added PD number

Sept 19, 2016

Corrected typos:

"All voltage parameters are absolute voltages referenced to COM;"

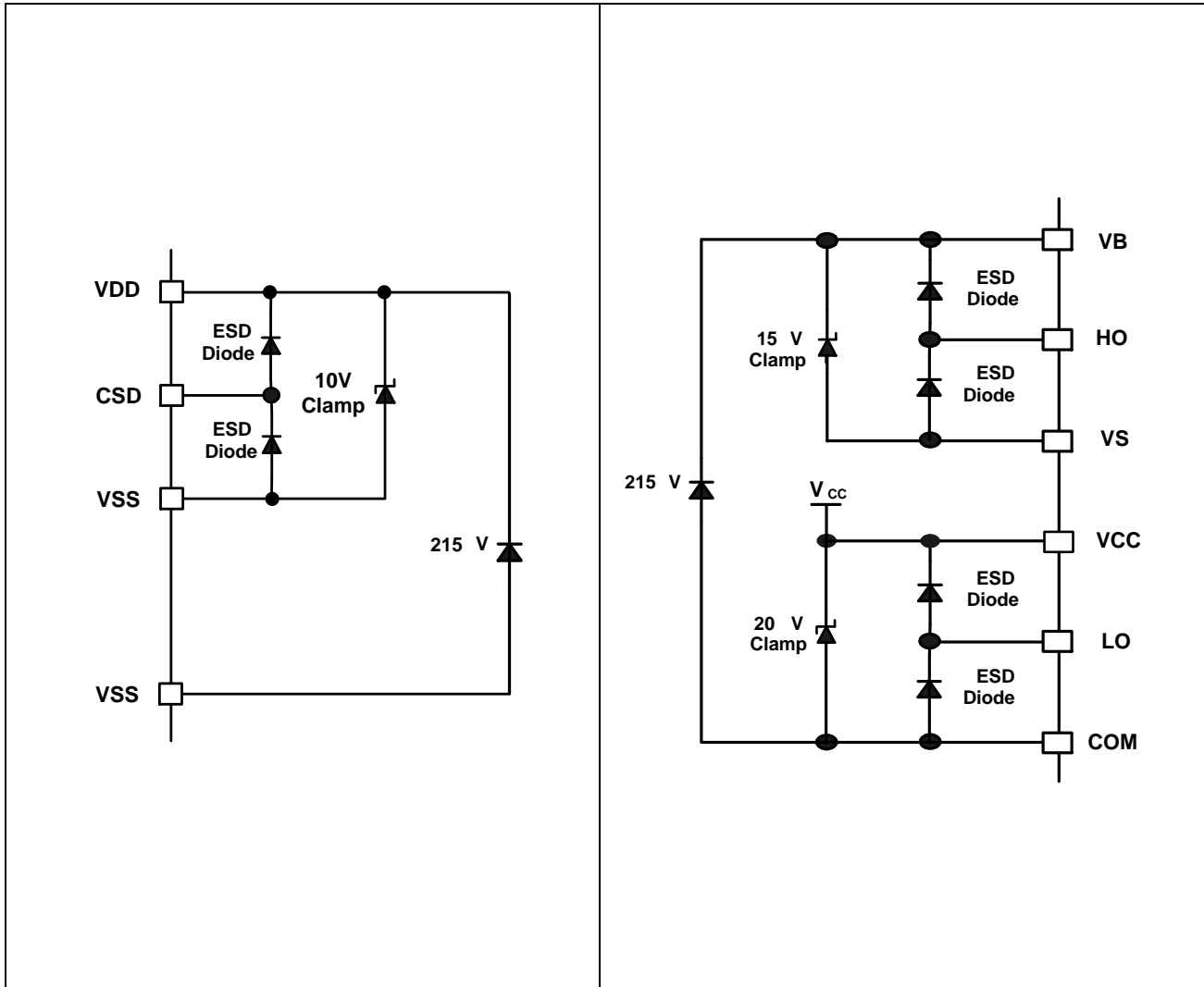

Компания «Life Electronics» занимается поставками электронных компонентов импортного и отечественного производства от производителей и со складов крупных дистрибьюторов Европы, Америки и Азии.

С конца 2013 года компания активно расширяет линейку поставок компонентов по направлению коаксиальный кабель, кварцевые генераторы и конденсаторы (керамические, пленочные, электролитические), за счёт заключения дистрибьюторских договоров

Мы предлагаем:

- Конкуренспособные цены и скидки постоянным клиентам.
- Специальные условия для постоянных клиентов.
- Подбор аналогов.
- Поставку компонентов в любых объемах, удовлетворяющих вашим потребностям.
- Приемлемые сроки поставки, возможна ускоренная поставка.
- Доставку товара в любую точку России и стран СНГ.
- Комплексную поставку.
- Работу по проектам и поставку образцов.
- Формирование склада под заказчика.
- Сертификаты соответствия на поставляемую продукцию (по желанию клиента).
- Тестирование поставляемой продукции.
- Поставку компонентов, требующих военную и космическую приемку.
- Входной контроль качества.
- Наличие сертификата ISO.

В составе нашей компании организован Конструкторский отдел, призванный помогать разработчикам, и инженерам.

Конструкторский отдел помогает осуществить:

- Регистрацию проекта у производителя компонентов.
- Техническую поддержку проекта.
- Защиту от снятия компонента с производства.
- Оценку стоимости проекта по компонентам.
- Изготовление тестовой платы монтаж и пусконаладочные работы.



Тел: +7 (812) 336 43 04 (многоканальный)

Email: org@lifeelectronics.ru