



PT/SPT SERIES PHOTOCONTROL

THERMAL, NON METALLIC HOUSING, WIRE-IN

KEY FEATURES

- Fixed or adjustable swivel base
- Heavy-duty thermal bi-metal switch
- UL | CSA Listed
- 30 - 45 second time delay
- 2000 watt rating
- Fail mode is ON

TE Connectivity's (TE) PT/SPT Series offers a durable control with an optional swivel base allowing maximum mobility for installation.

The PT/SPT Series controls combine the superior performance of the AT Series with an economical, yet highly durable, polycarbonate housing.

Controls include a heavy-duty bi-metal switch that provides a 30 - 45 second time delay. This virtually eliminates unwanted lamp cycling that could be caused by lightning, car headlights, or other sudden changes in ambient light level.

Although the Turn-ON level is pre-set at the factory, each PT and SPT control is furnished with an adjustable slide bar that allows field adjustment to satisfy specific needs. The SPT is also equipped with an adjustable swivel base to provide installation flexibility.

Customers can count on consistent, high quality products, driven by TE's proven innovation and backed by our extraordinary customer support.



TE's photocontrols can be used to safely control luminaries with incandescent, HID, LED, or compact fluorescent lamps.

TECHNICAL INFORMATION	
Switch	SPST thermal bi-metallic, Exceeds 5,000 ON/OFF operations
Fail Mode	ON (contacts normally closed)
Housing	Polycarbonate with UV stabilized window
Lead Wires	6", #14 AWG, rated 105°C (all other models)
Nipple	1/2" pipe
Nut	1/2" pipe, die-cast

SPECIFICATION	
Physical	Enclosure: designed to meet UL 773A
	Power consumption: less than 0.9 watts at 120 VAC
Temperature	Minus 40°C to plus 65°C at 96% RH
Load Rating	2000 Watt Tungsten 1900 VA ballast
Light Sensor	Cadmium Sulfide Cell

Figures A & B: Illustrates front and side view of PT Model

Figures C & D: Illustrates front and side view of SPT Model

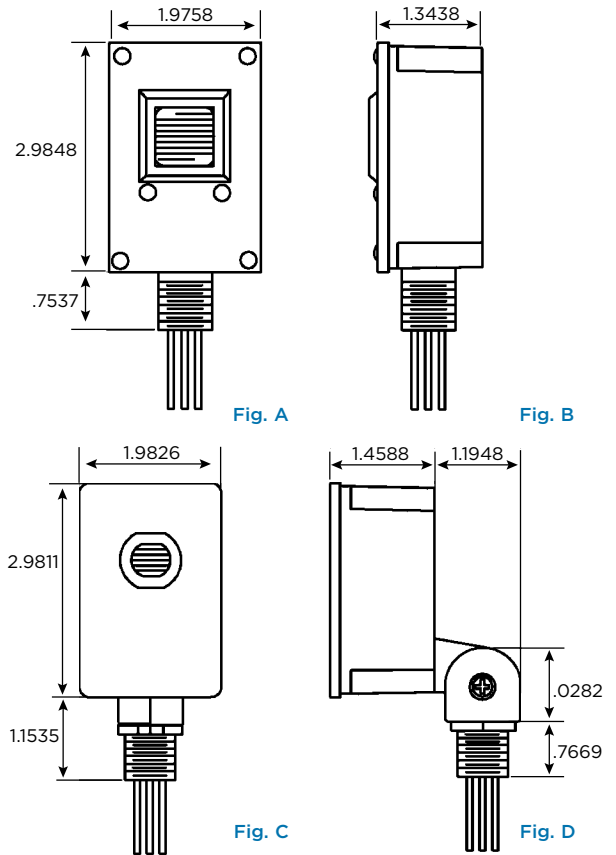

PRODUCT SELECTION INFORMATION							
Description	Base	Rated Volts	Range (Volts)	Load Rating Tungsten (Watts)	Load Rating Ballast (VA)	Turn ON (Fc)	OFF/ON Ratio
PT-15	Fixed	120	105 - 130	2000	1900	1.5	4 : 1
PT-168	Fixed	208/240/277	185 - 305	2000	1900	1.5	4 : 1
PT-20	Fixed	120/208/240/277	105 - 305	2000	1900	1.5	4 : 1
PT-347**	Fixed	347	310 - 380	2000	1900	1.5	4 : 1
SPT-15	Swivel	120	105 - 130	2000	1900	1.5	4 : 1
SPT-168	Swivel	208/240/277	185 - 305	2000	1900	1.5	4 : 1
SPT-19*	Swivel	480	420 - 530	2000	1900	1.5	4 : 1
SPT-347**	Swivel	347	310 - 380	2000	1900	1.5	4 : 1

Note: 6" Lead Wires
* Not UL or CSA Listed
** CSA Listed Only



te.com/energy

©2008, 2012, 2014 TE Connectivity Ltd. family of companies. All Rights Reserved. 9-1773453-4 E335 10/2014

TE Connectivity and TE connectivity (logo) are trademarks. Other logos, product and/or company names might be trademarks of their respective owners. While TE has made every reasonable effort to ensure the accuracy of the information in this brochure, TE does not guarantee that it is error-free, nor does TE make any other representation, warranty or guarantee that the information is accurate, correct, reliable or current. TE reserves the right to make any adjustments to the information contained herein at any time without notice. TE expressly disclaims all implied warranties regarding the information contained herein, including, but not limited to, any implied warranties of merchantability or fitness for a particular purpose. The dimensions in this catalog are for reference purposes only and are subject to change without notice. Specifications are subject to change without notice. Consult TE for the latest dimensions and design specifications.

FOR MORE INFORMATION: TE Technical Support Centers

- USA: +1 800 327 6996
- France: +33 380 583 200
- UK: +44 0870 870 7500
- Germany: +49 896 089 903
- Spain: +34 916 630 400
- Benelux: +32 16 351 731
- Canada: +1 (905) 475-6222
- Mexico: +52 (0) 55-1106-0800
- Latin/S. America: +54 (0) 11-4733-2200
- China: +86 (0) 400-820-6015

Компания «Life Electronics» занимается поставками электронных компонентов импортного и отечественного производства от производителей и со складов крупных дистрибьюторов Европы, Америки и Азии.

С конца 2013 года компания активно расширяет линейку поставок компонентов по направлению коаксиальный кабель, кварцевые генераторы и конденсаторы (керамические, пленочные, электролитические), за счёт заключения дистрибьюторских договоров

Мы предлагаем:

- Конкурентоспособные цены и скидки постоянным клиентам.
- Специальные условия для постоянных клиентов.
- Подбор аналогов.
- Поставку компонентов в любых объемах, удовлетворяющих вашим потребностям.
- Приемлемые сроки поставки, возможна ускоренная поставка.
- Доставку товара в любую точку России и стран СНГ.
- Комплексную поставку.
- Работу по проектам и поставку образцов.
- Формирование склада под заказчика.
- Сертификаты соответствия на поставляемую продукцию (по желанию клиента).
- Тестирование поставляемой продукции.
- Поставку компонентов, требующих военную и космическую приемку.
- Входной контроль качества.
- Наличие сертификата ISO.

В составе нашей компании организован Конструкторский отдел, призванный помогать разработчикам, и инженерам.

Конструкторский отдел помогает осуществить:

- Регистрацию проекта у производителя компонентов.
- Техническую поддержку проекта.
- Защиту от снятия компонента с производства.
- Оценку стоимости проекта по компонентам.
- Изготовление тестовой платы монтаж и пусконаладочные работы.



Тел: +7 (812) 336 43 04 (многоканальный)

Email: org@lifeelectronics.ru