

## 100mA Wireless Li-Ion Charger with Low Battery Disconnect

### FEATURES

- Complete Wireless Power Receiver, Li-Ion Charger and PowerPath™ Controller
- Wireless Input Power Control and Rectification
- Wideband Wireless Power Frequency: DC to >10MHz
- Pin-Selectable Charge Current:  
10mA/25mA/50mA/100mA
- Pin-Selectable Charge Voltage: 4.0V/4.1V/4.2V/4.35V
- Pin-Selectable Low Battery Disconnect: 2.7V/3.2V
- Zero Battery Drain Current in Disconnect/Ship Mode
- Pin-Selectable Low Battery Pre-Charge Current Enable
- NTC Input for Temperature Qualified Charging
- Safety Charge Termination Timer
- Tiny Total Solution Size with Few Externals
- Small Thermally Enhanced 12-lead  
2mm × 2mm LQFN Package

### APPLICATIONS

- Medical Wireless Sensors
- Military Wearables
- High End Wireless Headsets
- Streaming Headsets with Bluetooth Connectivity
- Virtual Reality Headsets
- High End Remote Control
- IoT Devices

### DESCRIPTION

The LTC<sup>®</sup>4124 is a simple high performance wireless Li-Ion charger with low battery disconnect. The pin-selectable charge current (up to 100mA) and charge voltage ensure versatility while minimizing the number of required external components.

Wireless charging with the LTC4124 allows devices to be charged while sealed within enclosures and eliminates bulky connectors in space-constrained applications. Elimination of exposed conductive connectors also creates more robust devices while ensuring an effortless end-user experience.

The LTC4124 includes an NTC input for safe temperature qualified charging and a battery disconnect feature that prevents damage to a battery due to over-discharging.

The 2mm × 2mm LQFN package and minimal number of external components make the LTC4124 well-suited for low power portable applications where small solution size is mandatory.

All registered trademarks and trademarks are the property of their respective owners.

### TYPICAL APPLICATION

10mA Wireless 4.2V Li-Ion Charger with 1mA Pre-Charge Conditioning and 2.7V Low Battery Disconnect

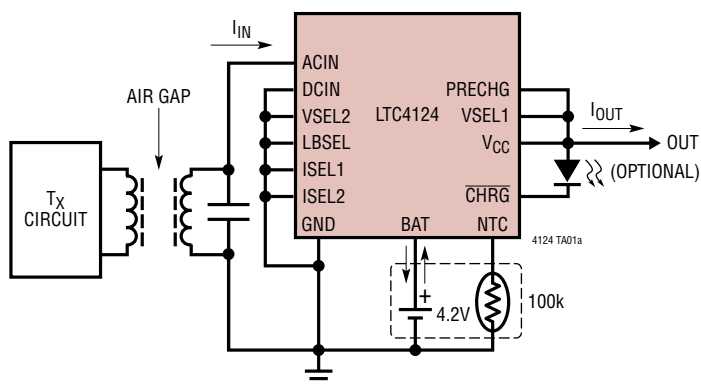

Top and Bottom View of the IC with Complete Application Circuit Boards

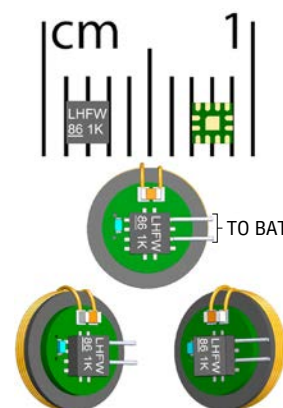

# LTC4124

## ABSOLUTE MAXIMUM RATINGS

(Notes 1, 2)

### Input Supply Voltages

DCIN, V<sub>CC</sub>, BAT ..... -0.3V to 6V

ACIN ..... V<sub>CC</sub> - 40V to V<sub>CC</sub> + 0.3V

### Input Supply Currents

I(ACIN) ..... 200mA

I(DCIN) ..... 200mA

CHRG ..... -0.3V to V<sub>CC</sub> + 0.3V

### Programming Pins

VSEL1, VSEL2, ISEL1, ISEL2 ..... -0.3V to V<sub>CC</sub> + 0.3V

NTC, LBSEL, PRECHG ..... -0.3V to V<sub>CC</sub> + 0.3V

### Operating Junction Temperature Range

(Note 3) ..... -20°C to 85°C

Storage Temperature Range ..... -40°C to 125°C

Maximum Reflow (Package Body)

Temperature ..... 260°C

## PIN CONFIGURATION

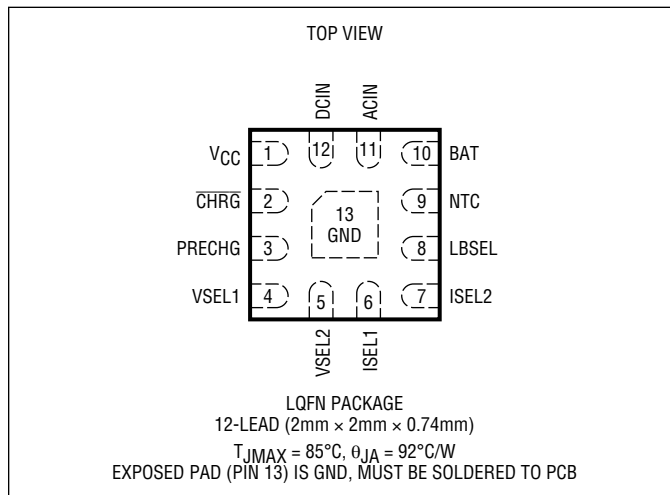

## ORDER INFORMATION

PART NUMBER	PART MARKING*	FINISH CODE	PAD FINISH	PACKAGE** TYPE	MSL RATING	TEMPERATURE RANGE
LTC4124EV#TRPBF	LHFW	e4	Au (RoHS)	LQFN (Laminate Package with QFN Footprint)	3	-20°C to 85°C
LTC4124EV#TRMPBF	LHFW	e4	Au (RoHS)	LQFN (Laminate Package with QFN Footprint)	3	-20°C to 85°C

- Contact the factory for parts specified with wider operating temperature ranges. \*Device temperature grade is identified by a label on the shipping container.
- Pad finish code is per IPC/JEDEC J-STD-609.

- [Recommended LGA and BGA PCB Assembly and Manufacturing Procedures](#)
- [LGA and BGA Package and Tray Drawings](#)

Parts ending with PBF are RoHS and WEEE compliant. \*\*The LTC4124 package has the same dimensions as a standard 2mm × 2mm × 0.74mm QFN Package.

## ELECTRICAL CHARACTERISTICS

The ● denotes the specifications which apply over the specified operating junction temperature range, otherwise specifications are at  $T_A = 25^\circ\text{C}$ .  $V_{CC} = 5\text{V}$  unless otherwise noted (Notes 2, 3).

SYMBOL	PARAMETER	CONDITIONS	MIN	TYP	MAX	UNITS
$V_{DCIN}$	DC Input Supply Operating Range		● 3.3		5.5	V
$V_{CC}$	Supply Operating Range		● 2.7		5.5	V
$I_{VCC}$	Input Quiescent Current	$V_{CC} = 5\text{V}$ , Not Charging	●	120	250	$\mu\text{A}$
$I_{BAT}$	Battery Quiescent Current	Done Charging or Not Charging, $V_{CC} > V_{BAT}$	●	3.5	7	$\mu\text{A}$
		Ideal Diode Mode, $ACIN = DCIN = 0\text{V}$ , NTC = $V_{CC}$ or Open	●	8 8	15 80	$\mu\text{A}$ $\mu\text{A}$
		Ideal Diode Mode, $ACIN = DCIN = 0\text{V}$ , NTC = $100\text{k}\Omega$ to GND	●	28 28	35 100	$\mu\text{A}$ $\mu\text{A}$
		Disconnect Mode, $V_{BAT} < V_{BAT\_LBDIS}$ , $ACIN = DCIN = V_{CC} = 0\text{V}$	●	0	50	nA
		Ship Mode, at any $V_{BAT}$ Voltage Level, $ACIN = DCIN = V_{CC} = 0\text{V}$	●	0	50	nA

### Wireless and DC Power Management

$\Delta V_{CC(HIGH)}$	$V_{CC}$ High Voltage Limit above $V_{BAT}$	$V_{CC}$ Rising, $V_{BAT} = 3.6\text{V}$		1.05		V
$\Delta V_{CC(LOW)}$	$V_{CC}$ Low Voltage Limit above $V_{BAT}$	$V_{CC}$ Falling, $V_{BAT} = 3.6\text{V}$		0.85		V
	ACIN to $V_{CC}$ Voltage Drop	$V_{ACIN} = 5\text{V}$ , $V_{DCIN} = 0\text{V}$ , $I_{VCC} = -100\text{mA}$ , Not Charging		0.45		V
	DCIN to $V_{CC}$ Voltage Drop	$V_{DCIN} = 5\text{V}$ , $V_{ACIN} = 0\text{V}$ , $I_{VCC} = -100\text{mA}$ , Not Charging		0.45		V

### Battery Charging

$V_{UVCL}$	$V_{CC}$ Undervoltage Current Limit Regulation Point	$I_{SEL1} = I_{SEL2} = V_{CC}$ , $I_{CHG} = 1\text{mA}$ (10%)		3.4		V	
$V_{UVCL\_TH}$	$V_{CC}$ Fault Indicator Threshold into UVCL	$V_{CC}$ Falling, $V_{BAT} = 3.0\text{V}$		3.45		V	
	Hysteresis	$V_{BAT} = 3.0\text{V}$		50		mV	
$R_{CHG}$	Charge Switch On Resistance	$V_{BAT} = 3.6\text{V}$		0.5		$\Omega$	
$V_{BAT\_REG}$	Battery Charge Voltage	$V_{SEL1} = V_{SEL2} = V_{CC}$	●	4.339	4.350	4.361	V
			●	4.285	4.350	4.415	V
		$V_{SEL1} = V_{CC}$ , $V_{SEL2} = \text{GND}$		4.190	4.200	4.210	V
			●	4.137	4.200	4.263	V
		$V_{SEL1} = \text{GND}$ , $V_{SEL2} = V_{CC}$		4.090	4.100	4.110	V
			●	4.038	4.100	4.162	V
$V_{BAT\_RECHG}$	Recharge Battery Threshold Voltage	$V_{BAT}$ Falling, % of $V_{BAT\_REG}$	●	96.0	97.6	98.6	%
	Hysteresis	% of $V_{BAT\_REG}$		0.3		%	
$V_{BAT\_TRKL}$	Precharge Battery Voltage Threshold	$V_{BAT}$ Rising, % of $V_{BAT\_REG}$	●	65	68	71	%
	Hysteresis	% of $V_{BAT\_REG}$		1		%	
$I_{CHG}$	Charge Current in Constant Current Mode	$I_{SEL1} = I_{SEL2} = V_{CC}$	●	95	100	103.5	mA
		$I_{SEL1} = V_{CC}$ , $I_{SEL2} = \text{GND}$	●	45	50	53.5	mA
		$I_{SEL1} = \text{GND}$ , $I_{SEL2} = V_{CC}$	●	22	25	27.5	mA
		$I_{SEL1} = I_{SEL2} = \text{GND}$	●	8.5	10.0	11.5	mA
$I_{CHG(PRE)}$	Precharge Current	$V_{PRECHG} = V_{CC}$ , % of $I_{CHG}$	●	6	10	14	%

## ELECTRICAL CHARACTERISTICS

The ● denotes the specifications which apply over the specified operating junction temperature range, otherwise specifications are at  $T_A = 25^\circ\text{C}$ .  $V_{CC} = 5\text{V}$  unless otherwise noted (Notes 2, 3).

SYMBOL	PARAMETER	CONDITIONS	MIN	TYP	MAX	UNITS
$I_{C/10}$	C/10 Current Threshold in Constant Voltage Mode	$I_{BAT}$ Falling, % of $I_{CHG}$		10		%
	Hysteresis			1		%
$t_T$	Charge Termination Time		● 2.2	3.0	4.0	hours
$t_{BB}$	Bad Battery Detection Time		● 30	45	60	mins
$V_{NTC(COLD)}$	NTC Cold Threshold	$V_{NTC}$ Rising, % of $V_{CC}$	● 73	75	77	%
$V_{NTC(HOT)}$	NTC Hot Threshold	$V_{NTC}$ Falling, % of $V_{CC}$	● 33	35	37	%
$V_{NTC(HYS)}$	NTC Thresholds Hysteresis	% of $V_{CC}$		5		%
$R_{NTC(OPEN)}$	NTC Open Circuit Input Resistance to $V_{CC}$	$I_{NTC} = -25\mu\text{A}$	● 98.5	100	101.5	$k\Omega$
$V_{NTC(DIS)}$	NTC Disable Threshold	$V_{NTC}$ Rising, % of $V_{CC}$	● 90	94	98	%
	Hysteresis	% of $V_{CC}$		5		%

### Battery Discharging

	Battery Discharge PowerPath Forward Regulation Voltage	$V_{BAT,VCC}$ , $I_{VCC} = -1\text{mA}$ , $V_{BAT} \geq V_{BAT\_LBDIS}$		0	55	130	mV
	Battery PowerPath Forward Turn-On Threshold Voltage	$V_{BAT,VCC}$			100		mV
	Battery PowerPath Reverse Turn-Off Threshold Voltage	$V_{BAT,VCC}$ , Not Charging			-100		mV
$R_{DISCHG}$	Discharge Switch On Resistance	$V_{BAT} = 3.6\text{V}$			0.5		$\Omega$
	Maximum Battery Discharge Current Threshold for Safety Disconnect	$V_{BAT} = 3.6\text{V}$			1.0		A

### Low Battery Disconnect

$V_{BAT\_LBDIS}$	Low Battery Disconnect Voltage	$LBSEL = V_{CC}$ , $V_{BAT}$ Falling	● 3.136	3.200	3.264	V
		$LBSEL = GND$ , $V_{BAT}$ Falling	● 2.646	2.700	2.754	V
$I_{BAT(LEAK)}$	Battery Leakage Current When Disconnected	$V_{BAT} < V_{BAT\_LBDIS}$	●	0	50	nA

### CHRG Status Pin

$I_{CHRG(LKG)}$	CHRG Open Drain Leakage Current	$V_{CHRG} = 5\text{V}$			1	$\mu\text{A}$	
$I_{CHRG}$	CHRG Pull Down Current	$V_{CHRG} = 400\text{mV}$		200	300	400	$\mu\text{A}$
$f_{BLINK(SLW)}$	Blink Slow Frequency			0.6	0.8	1.1	Hz
$f_{BLINK(FAST)}$	Blink Fast Frequency			4.5	6	8	Hz

### Digital Input Pins (VSEL1, VSEL2, ISEL1, ISEL2, LBSEL, PRECHG)

$V_{IL}$	Input Voltage Low		● 0.4			V
$V_{IH}$	Input Voltage High		●		$V_{CC} - 0.4\text{V}$	V
	Input Leakage Current	$0\text{V} \leq V_{PIN} \leq V_{CC}$	●	-1	1	$\mu\text{A}$

**Note 1:** Stresses beyond those listed under Absolute Maximum Ratings may cause permanent damage to the device. Exposure to any Absolute Maximum Rating condition for extended periods may affect device reliability and lifetime.

**Note 2:** All currents into pins are positive; all voltages are referenced to GND unless otherwise noted.

**Note 3:** The LTC4124 is tested under conditions such that  $T_J \approx T_A$ . The LTC4124E is guaranteed to meet specifications from  $0^\circ\text{C}$  to  $85^\circ\text{C}$  junction temperature. Specifications over the  $-20^\circ\text{C}$  to  $85^\circ\text{C}$  operating junction

temperature are assured by design, characterization and correlation with statistical process controls. Note that the maximum ambient temperature consistent with these specifications is determined by specific operating conditions in conjunction with board layout, the rated package thermal impedance and other environmental factors. The junction temperature ( $T_J$ , in  $^\circ\text{C}$ ) is calculated from the ambient temperature ( $T_A$ , in  $^\circ\text{C}$ ) and power dissipation ( $P_D$ , in Watts) according to the following formula:

$$T_J = T_A + (P_D \cdot \theta_{JA}), \text{ where } \theta_{JA} \text{ (in } ^\circ\text{C/W) is the package thermal impedance.}$$

**TYPICAL PERFORMANCE CHARACTERISTICS**  $T_A = 25^\circ\text{C}$ , unless otherwise noted.

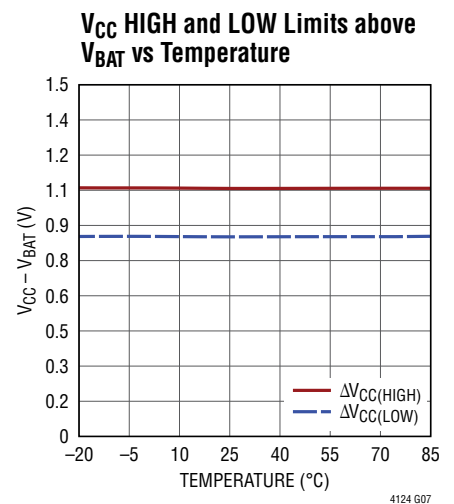
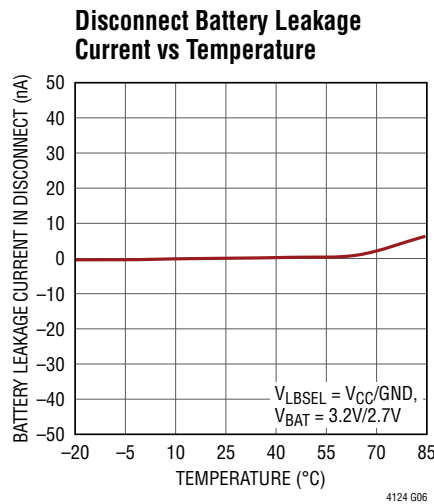
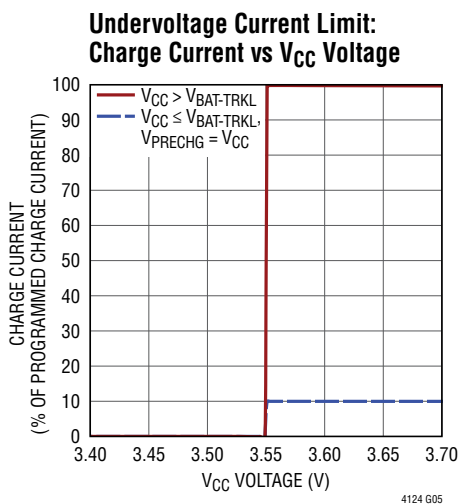
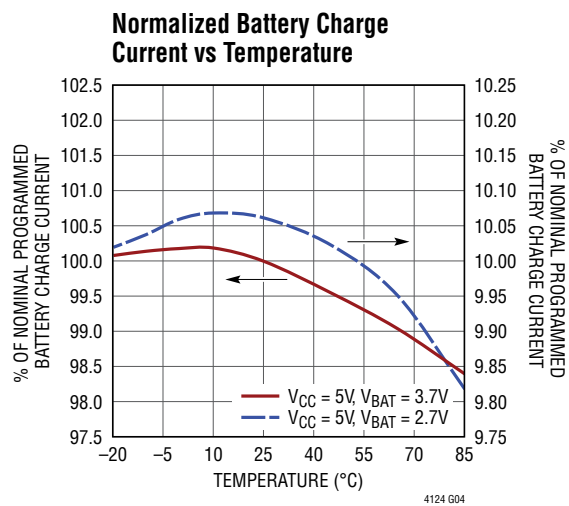
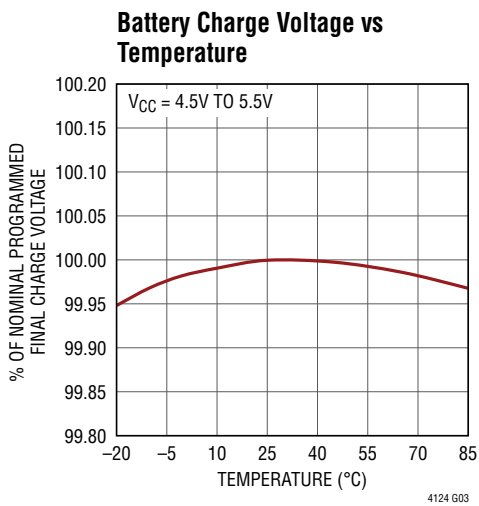
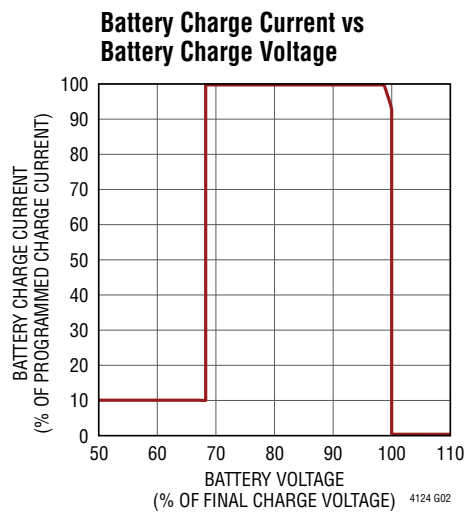
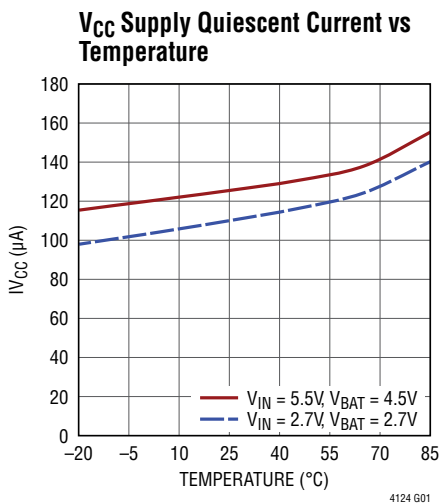

## TYPICAL PERFORMANCE CHARACTERISTICS $T_A = 25^\circ\text{C}$ , unless otherwise noted.

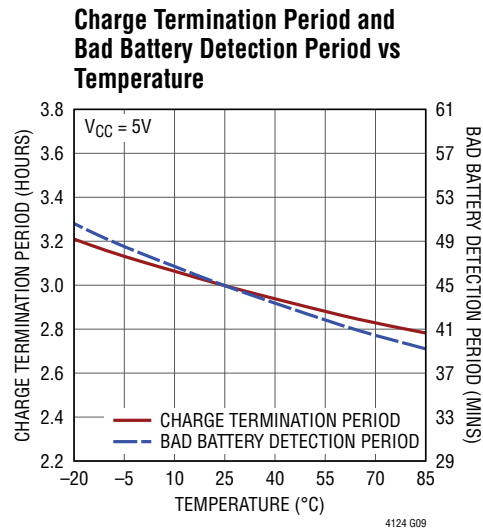
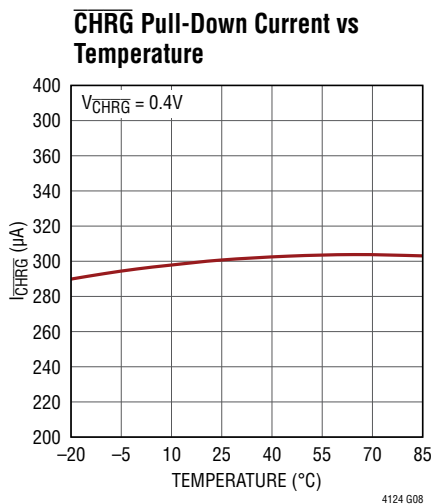

## PIN FUNCTIONS

**V<sub>CC</sub> (Pin 1):** System DC Supply. The V<sub>CC</sub> voltage range is 2.7V to 5.5V. An internal diode is connected from the ACIN pin (anode) to this pin (cathode), and a second one is connected from the DCIN pin (anode) to this pin (cathode). The voltage on this pin will be determined by the higher of the DCIN voltage and the peak AC voltage on the ACIN pin. There is an internal 2.2µF rectification capacitor connected between this pin and GND. Optional additional capacitance can be connected externally between this pin and GND.

**CHRG (Pin 2):** Charge Status Indicator. This pin is an open drain output with a 300µA current source pull down. In a typical application, this pin is pulled up by an LED to V<sub>CC</sub>. This pin has four possible states shown in Table 1.

**Table 1. CHRG States**

CHRG	Status
High Impedance	No Input Power
Blink Slow (0.8Hz)	Powered On and Charging
Blink Fast (6Hz)	Charging Paused due to Battery Temperature Out of Range, or
	Charging Stopped due to Bad Battery Detected, or Limited Charging due to Undervoltage Current Limit
Pull Down	End of Charge C/10 Reached or Charging Complete

**PRECHG (Pin 3):** Precharge Enable. Tie this pin to V<sub>CC</sub> to enable low current precharge at battery voltages below the precharge battery threshold (V<sub>BAT\_TRKL</sub>). Tie this pin to GND to disable low current precharge. When low current precharge is disabled, full charge current will be delivered for battery voltages below the final charge voltage. Do not leave this pin open.

**VSEL1 (Pin 4):** Charge Voltage Select Bit 1. Tie this pin to V<sub>CC</sub> or GND to program the battery charge voltage. Do not leave this pin open. Refer to Table 2 for programming the desired charge voltage.

**VSEL2 (Pin 5):** Charge Voltage Select Bit 2. Tie this pin to V<sub>CC</sub> or GND to program the battery charge voltage. Do not leave this pin open. Refer to Table 2 for programming the desired charge voltage.

**Table 2. Battery Charge Voltage Programming**

VSEL1	VSEL2	Charge Voltage
High	High	4.35V
High	Low	4.20V
Low	High	4.10V
Low	Low	4.00V

## PIN FUNCTIONS

**ISEL1 (Pin 6):** Charge Current Select Bit 1. Tie this pin to  $V_{CC}$  or GND to program the battery charge current. Do not leave this pin open. Refer to Table 3 for programming the desired charge current.

**ISEL2 (Pin 7):** Charge Current Select Bit 2. Tie this pin to  $V_{CC}$  or GND to program the battery charge current. Do not leave this pin open. Refer to Table 3 for programming the desired charge current.

**Table 3. Battery Charge Current Programming**

ISEL1	ISEL2	Charge Current
High	High	100mA
High	Low	50mA
Low	High	25mA
Low	Low	10mA

**LBSEL (Pin 8):** Low Battery Disconnect Voltage Select. Tie this pin to  $V_{CC}$  or GND to program the low battery disconnect voltage level. Do not leave this pin open. Refer to Table 4 for programming the desired low battery disconnect voltage level.

**Table 4. Low Battery Disconnect Voltage Programming**

LBSEL	Disconnect Voltage
High	3.2V
Low	2.7V

**NTC (Pin 9):** Thermistor Input. Connect a 100k $\Omega$  thermistor from NTC to GND. This pin is internally pulled up with a 100k $\Omega$ , 1% resistor to  $V_{CC}$ . The voltage level on this pin determines if the battery temperature is safe for charging. Charging and the charge timer are paused if the thermistor indicates temperature that is unsafe for charging. Once the temperature returns to the safe region, charging and the charge timer resume. Connect this pin to  $V_{CC}$  to disable the temperature qualified charging feature.

**BAT (Pin 10):** Battery. Connect the Li-Ion battery to this pin.

**ACIN (Pin 11):** AC Input Supply Voltage. Connect the external LC tank (receive inductor and capacitor) to this pin. An internal diode is connected from this pin (anode) to the  $V_{CC}$  pin (cathode). This pin supplies power to the  $V_{CC}$  pin when its peak voltage is higher than the DCIN pin voltage. Short this pin to GND when not used.

**DCIN (Pin 12):** Optional DC Input Supply Voltage: 3.3V to 5.5V. An internal diode is connected from this pin (anode) to the  $V_{CC}$  pin (cathode). This pin supplies power to the  $V_{CC}$  pin when its voltage is higher than the peak voltage of the ACIN pin. Short this pin to GND when not used.

**GND (Exposed Pad, Pin 13):** Device Ground. Connect this ground pin to a suitable PCB copper ground plane for proper electrical operation and rated thermal performance.

FUNCTIONAL BLOCK DIAGRAM

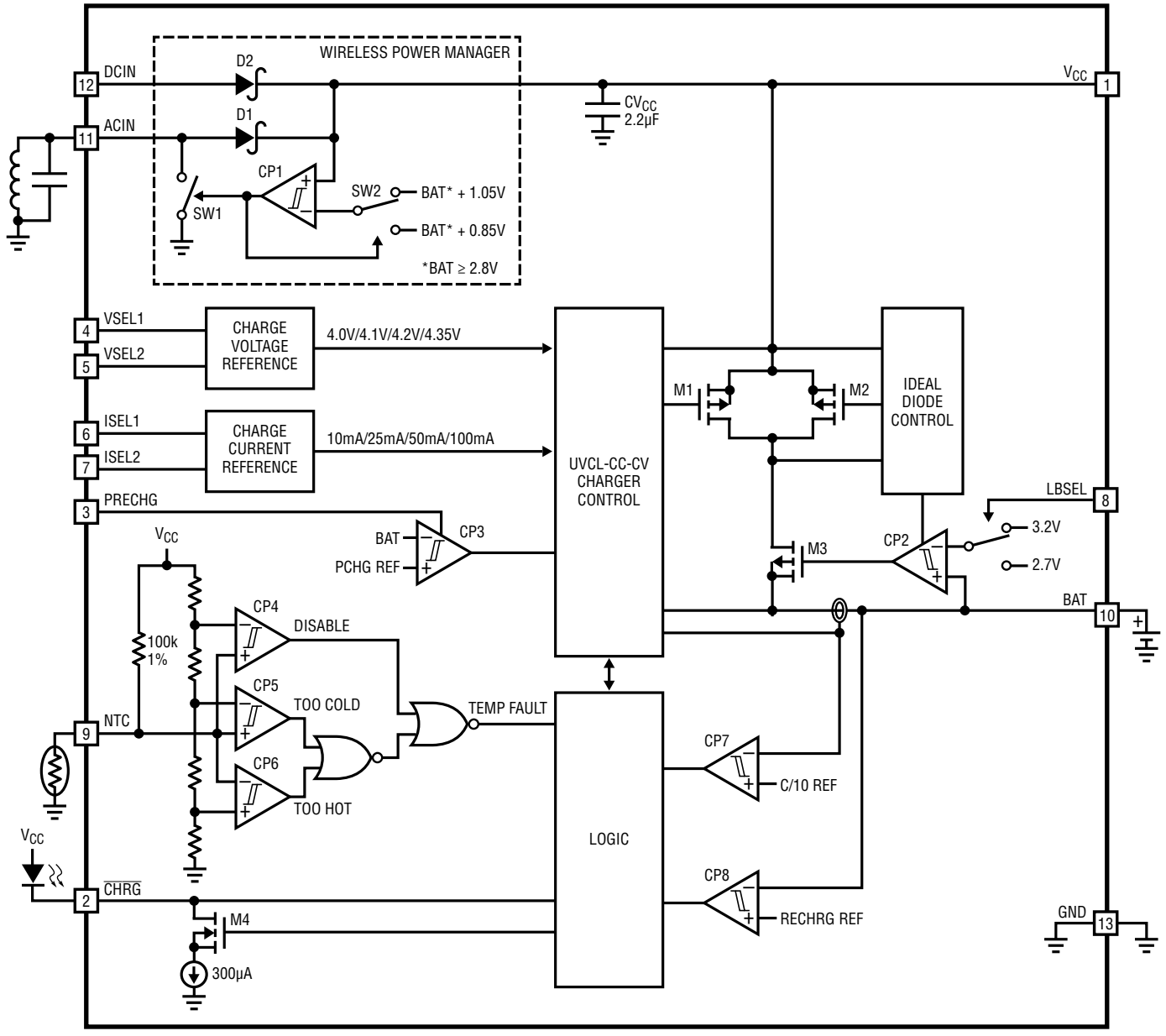

4124 BD



## OPERATION

The LTC4124 is a wireless single cell Li-Ion battery charger. The part has three main components: a wireless power manager, a full-featured linear battery charger and an ideal diode PowerPath™ controller.

### WIRELESS POWER MANAGER

A complete wireless power transfer system consists of transmit circuitry with a transmit coil and receive circuitry with a receive coil (Figure 1). The LTC4124 connected to an LC tank creates a simple and complete receiver half of the wireless power transfer system.

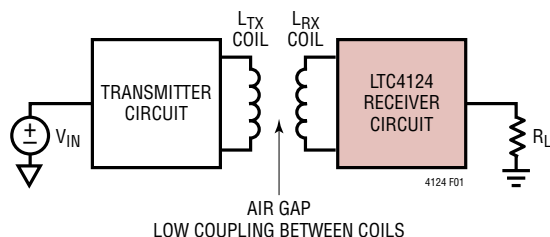

Figure 1. Wireless Power Transfer System

Refer to the Functional Block Diagram for the following discussion. An external parallel resonant LC tank connected to the ACIN pin allows the LTC4124 to receive power wirelessly from an alternating magnetic field generated by a transmit coil. Diode D1 rectifies the AC voltage at the ACIN pin. Comparator CP1, switch SW1 and switch SW2 operate together to regulate the rectified voltage on the V<sub>CC</sub> pin to between 0.85V and 1.05V above the voltage on the BAT pin provided BAT ≥ 2.8V.

### Operation with an Optional DC Voltage Source

The LTC4124 can alternately be powered from a DC voltage source connected to the DCIN pin. Diodes D1 and D2 set V<sub>CC</sub> to the maximum of the voltage on the DCIN pin or the peak AC voltage on the ACIN pin. Therefore, the DCIN pin supplies power to the V<sub>CC</sub> pin only if its voltage is higher than instantaneous AC voltage on the ACIN pin.

### BATTERY CHARGER

The LTC4124 includes a pin programmable full-featured CC/CV (Constant Current/Constant Voltage) linear battery charger with safety timer termination, bad battery

detection, temperature qualified safe charging and automatic recharge. The charge voltage and charge current are pin-strap programmable according to Table 2 and Table 3 shown in the Pin Functions section.

Figure 2 and Figure 3 show a typical charging cycle. As soon as the voltage at the V<sub>CC</sub> pin reaches 3.4V, the charger attempts to charge the battery and a charge cycle is initiated. At the beginning of a charge cycle, when the battery voltage is typically less than the recharge threshold (97.6% of the final charge voltage), the charger is in CC mode and charges the battery at the full programmed current.

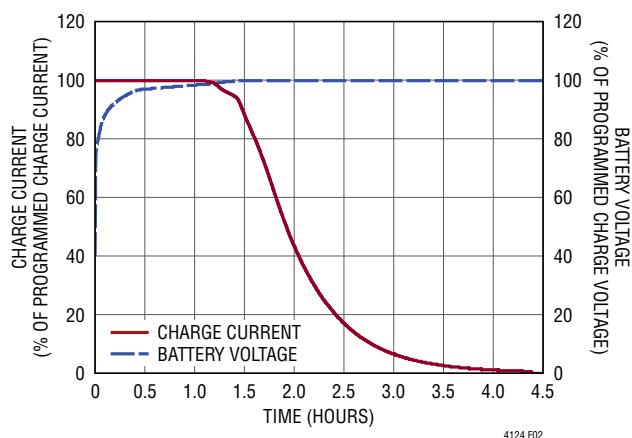

Figure 2. Typical Charging Cycle at 0.5C Rate vs Time with Pre-Charge Disabled

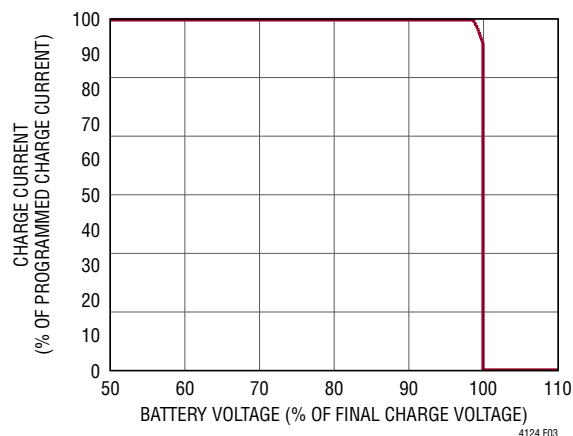

Figure 3. Typical Charge Current vs Battery Voltage in a Charging Cycle with Pre-Charge Disabled

## OPERATION

When the voltage on the BAT pin approaches the final charge voltage, the charger enters CV mode. The charge current begins to drop and a 3-hour charge termination timer starts. The charge current continues to drop while the BAT pin voltage is maintained at the proper charge voltage. Both CC and CV charging are indicated by a slow blink (0.8Hz) at the  $\overline{\text{CHRG}}$  pin.

In CV mode, when the charging current drops to 10% of the full programmed charge current, the  $\overline{\text{CHRG}}$  pin stops blinking and assumes a pull-down state, but charging continues at a continuously decreasing low charge current level. After the 3-hour charge termination time expires, charging stops completely. To start a new charge cycle, remove the power source at ACIN or DCIN and reapply it.

### Automatic Recharge

After charging has terminated and while still on the charger, the LTC4124 draws only 3.5 $\mu\text{A}$  from the battery. If it remains in this state for a long time (days for a typical battery with capacity  $\geq 10\text{mAh}$ ), the battery voltage will eventually drop enough due to this 3.5 $\mu\text{A}$  current and due to its own self-discharge to fall below the recharge threshold ( $V_{\text{BAT\_RECHG}}$ ).

To ensure that the battery is always topped off, a new charge cycle automatically begins when the battery voltage falls below  $V_{\text{BAT\_RECHG}}$  (typically 97.6% of the programmed charge voltage). In the event that the 3-hour safety timer is still running when the battery voltage falls below  $V_{\text{BAT\_RECHG}}$ , the timer resets back to zero.

### Trickle Charging – PRECHG Pin

Some battery manufacturers recommend low current pre-charging (trickle charge) for batteries that have been deeply discharged. Tying the PRECHG pin to  $V_{\text{CC}}$  enables the LTC4124 trickle charge feature.

When enabled, the trickle charge feature reduces the delivered charge current in CC mode to 10% of the full programmed charge current if the battery voltage is below the pre-charge battery voltage threshold ( $V_{\text{BAT\_TRKL}}$  is 68% of programmed charge voltage). Figure 4 and Figure 5 show a typical charging cycle with pre-charge enabled.

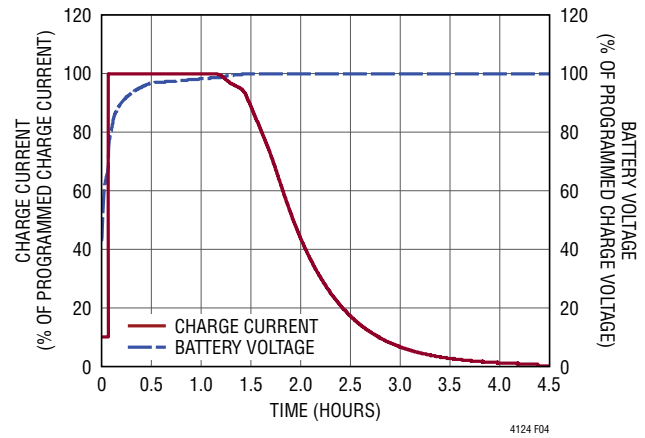

**Figure 4. Typical Charging Cycle at 0.5C Rate vs Time with Pre-Charge Enabled**

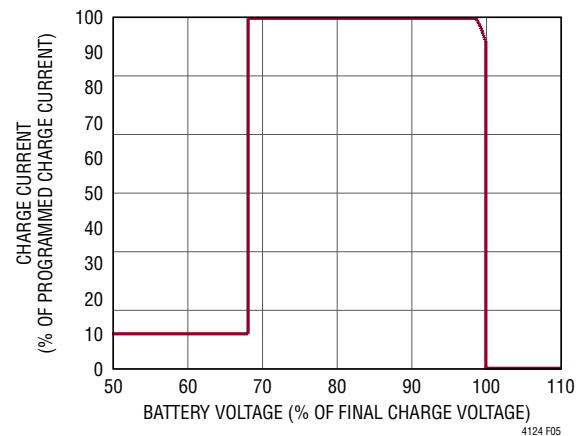

**Figure 5. Typical Charge Current vs Battery Voltage in a Charging Cycle with Pre-Charge Enabled**

Note that tying the PRECHG pin to GND disables the LTC4124 trickle charge feature. When disabled, full charge current is delivered to the battery in CC mode, resulting in the typical charge cycle as shown in Figure 2 and Figure 3.

### Bad Battery Fault

If during any charging cycle, the battery voltage stays below the pre-charge  $V_{\text{BAT\_TRKL}}$  for longer than the bad battery detection time ( $t_{\text{BB}}$ ), the battery is deemed faulty and the  $\overline{\text{CHRG}}$  pin indicates this bad battery fault condition by blinking fast (6Hz).

## OPERATION

### UVCL

The LTC4124 charger also includes undervoltage current limiting (UVCL) which gradually reduces the charge current from the full programmed value towards zero as the  $V_{CC}$  voltage drops to 3.4V. When the  $V_{CC}$  voltage is less than 3.45V, the  $\overline{CHRG}$  pin blinks fast (6Hz) to indicate a UVCL fault.

This feature is particularly useful in situations where the wireless power available is limited. Without UVCL, if the magnetic coupling between the receive coil and the transmit coil is low, the  $V_{CC}$  voltage could be forced below the acceptable minimum operating voltage (2.7V) when the charger tried to provide the full charge current. When this  $V_{CC}$  minimum operating voltage is not met, the LTC4124 forces the charge current to drop to zero instantly, allowing the  $V_{CC}$  voltage to rise above this minimum operating voltage and thus turn on the charger again.

This oscillatory behavior would result in intermittent charging. The UVCL feature prevents this undesirable behavior by gradually increasing or decreasing the charge current as input power becomes more or less available.

### Temperature Qualified Charging – NTC

The LTC4124 also includes an NTC pin, which provides for temperature qualified charging when connected to a 100k $\Omega$  NTC (negative temperature coefficient) thermistor thermally coupled to the battery. Comparators CP5 and CP6 implement the temperature detection as shown in the Functional Block Diagram.

The rising threshold of CP5 is set at 75% of  $V_{CC}$  (cold threshold) and the falling threshold of CP6 is set at 35% of  $V_{CC}$  (hot threshold). When the voltage at the NTC pin is above 75% of  $V_{CC}$  or below 35% of  $V_{CC}$ , the LTC4124 pauses any charge cycle in progress. When the voltage at the NTC pin returns within the range of 40% to 70% of  $V_{CC}$ , charging resumes.

When charging is paused, the charge current drops to zero. If the LTC4124 is charging in constant voltage mode and the charge termination timer is running, the timer pauses until the thermistor indicates a return to a valid

temperature. Similarly, if the battery charger is in trickle charge mode and the bad battery detection timer is running, the bad battery timer pauses until the thermistor indicates a return to a valid temperature.

To disable the temperature qualified charging feature of the LTC4124, the NTC pin can be left open or shorted to the  $V_{CC}$  pin. In this configuration, comparator CP4 ensures that the output of the temperature detection comparators CP5 and CP6 are ignored and no temperature fault will be detected.

### Charge Status Indicator

The status of the battery charger is indicated via the open drain  $\overline{CHRG}$  pin. This pin has an internal 300 $\mu$ A pull-down current. An LED can be connected between this pin and  $V_{CC}$  to indicate the charging status and any fault condition as indicated in Table 1 shown in the Pin Functions section.

### Low Battery Disconnect

When no input power is available and the battery voltage falls below the disconnect voltage ( $V_{BAT\_LBDIS}$ ), the LTC4124 shuts down, opening disconnect switch M3 (Functional Block Diagram) and eliminating any current consumption from the battery. This protects the battery from discharging further and causing damage that will reduce battery lifetime. When the battery is in disconnect mode, normal functioning can only resume by applying power to the ACIN or DCIN pin.

The disconnect voltage level can be selected via the LBSEL pin according to Table 4 shown in the Pin Functions section.

### Ship Mode

The LTC4124 also provides a ship mode feature. When activated, this feature eliminates any current consumption from the battery at any battery voltage level. This feature ensures that all battery powered devices using the LTC4124 can be shipped out of the factory with a charged battery (conditioned for optimal storage life or fully charged) with the expectation that it is ready to be used (minimal discharge) the first time it reaches the end user.

## OPERATION

Ship mode activates when a 1.5V ( $\pm 100\text{mV}$ ) DC voltage is simultaneously applied to both the DCIN and the ACIN pins while the LTC4124 is in ideal diode mode (the battery is supporting the  $V_{CC}$  voltage at or above the battery disconnect voltage  $V_{BAT\_LBDIS}$ ).

Before entering ship mode, the voltage at  $V_{CC}$  will be at  $V_{BAT} - 50\text{mV}$ . As soon as 1.5V is simultaneously applied to the DCIN and ACIN pins, the voltage at  $V_{CC}$  will drop to a diode drop below 1.5V (approximately 0.7V), indicating that the part is now in ship mode. Finally, set the DCIN and ACIN pins to 0V to let the  $V_{CC}$  pin voltage drop to 0V.

In a typical setup, an  $R_X$  coil is connected between the ACIN pin and GND. Thus, driving the ACIN pin with a 1.5V DC voltage is not prudent without temporarily removing this coil connection. An alternate and more practical procedure for entering ship mode is as follows:

1. With DCIN = 0V, ensure that the LTC4124 is in ideal diode mode (the battery is supporting the  $V_{CC}$  voltage at or above the battery disconnect voltage  $V_{BAT\_LBDIS}$ ).
2. Turn on the transmitter and couple the  $T_X$  coil to the  $R_X$  coil so that the LTC4124 is in charging mode ( $V_{CC}$  is supported by ACIN at or above the battery voltage).
3. Drive the DCIN pin to 1.5V DC.
4. Turn off the transmitter.

5. Ensure that the  $V_{CC}$  voltage drops to a diode drop below 1.5V (approximately 0.7V).
6. Remove the 1.5V DC source from the DCIN pin and drive it to 0V.
7. Ensure that the  $V_{CC}$  voltage goes to 0V.

Once in ship mode, normal functioning of the LTC4124 can only resume again by applying power to the ACIN or DCIN pin to bring the voltage at  $V_{CC}$  above the 2.7V minimum operating voltage.

### IDEAL DIODE POWER PATH FROM BAT TO $V_{CC}$

When the LTC4124 is not in low battery disconnect mode nor in ship mode, the Ideal Diode Control block (Functional Block Diagram) regulates  $V_{CC}$  to achieve low loss conduction by driving the gate of M2 such that the voltage drop from the BAT pin to the  $V_{CC}$  pin is 50mV. At high load currents from  $V_{CC}$ , M2 is fully driven on with its on-resistance adding to that of M3 connecting BAT to  $V_{CC}$ .

The Charger Control block driving M1 together with the Ideal Diode Control block driving M2 allow for a smooth transition from charging mode to the low loss discharge mode. Note that in charging mode, current is flowing from the  $V_{CC}$  pin to the BAT pin. In the low loss discharge (ideal diode) mode, current is flowing from the BAT pin to support the  $V_{CC}$  pin voltage to be as close to that of the BAT pin as possible.

## APPLICATIONS INFORMATION

The LTC4124 is designed to be a highly integrated complete solution for a wireless single cell Li-Ion battery charger. As such its application circuit is simple with a minimal number of external components.

### COMPONENT SELECTION

In the simplest application with a DC input voltage and no wireless power input, a single cell Li-Ion battery charger with the LTC4124 requires no external components at all (Figure 6). Note that even though this simplest application is a complete functional single cell Li-Ion battery charger, it does not have the temperature qualified charging feature nor does it have any visual charge status indicator.

In order to include the temperature qualified charging, a negative temperature coefficient (NTC) thermistor needs to be added. To add a visual charge status indicator, an LED needs to be connected between the  $V_{CC}$  pin and the  $\overline{CHRG}$  pin. Figure 7 shows these two components added to the application circuit of Figure 6.

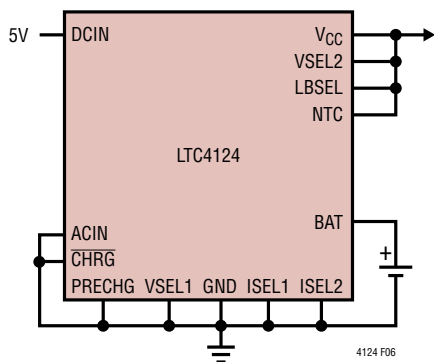

**Figure 6. Simplest 10mA Single Cell Li-Ion Charger with LTC4124 with No Temperature Qualified Charging and No Charge Status Indicator**

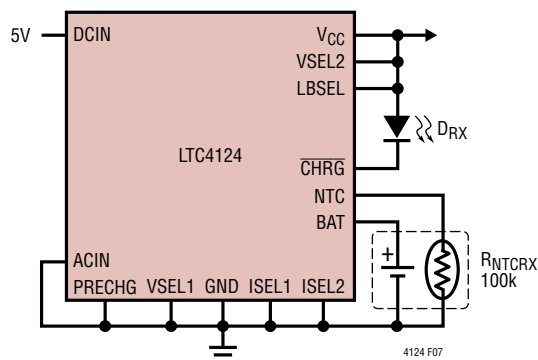

**Figure 7. Simple 10mA Single Cell Li-Ion Charger with DC Input**

### NTC Thermistor

To use the battery temperature qualified charging feature, connect a 100kΩ NTC thermistor between the NTC pin and GND. Thermistor manufacturer data sheets usually include either a temperature lookup table or a formula relating temperature to the resistance at that corresponding temperature. Table 5 shows some thermistors that can be used with the LTC4124.

**Table 5. Recommended NTC Thermistors**

Manufacturer	Part Number	Description
TDK	NTCG064EF104F	100kΩ, 1%, 0201
MURATA	NCP03WF104F	100kΩ, 1%, 0201

In the setup shown in Figure 7, the LTC4124 will pause charging at higher temperatures when the resistance of the NTC thermistor drops to 54kΩ. For the thermistors listed in Table 5, this corresponds to approximately 43°C. As temperature drops, the resistance of the NTC thermistor rises. The LTC4124 will also pause charging when the value of the NTC thermistor increases to 300kΩ. For the thermistors listed in Table 5, this corresponds to approximately 3°C. For the same thermistors in Table 5, the hot and cold comparators each have approximately 5°C of hysteresis to prevent oscillation about the trip point.

## APPLICATIONS INFORMATION

### LED

The LED connected to the  $\overline{\text{CHRG}}$  pin is powered by a 300 $\mu\text{A}$  pull-down current source. Select a high efficiency LED with a low forward voltage drop. Some recommended LEDs are shown in Table 6.

**Table 6. Recommended LEDs**

Manufacturer	Part Number	Description
Kingbright	APG0603VGC	Green, 0201
Kingbright	APG0603SEC-E-TT	Red, 0201

### Wireless Power Components

In order for the LTC4124 to receive power wirelessly, a parallel LC tank needs to be connected to the ACIN pin as shown in the Functional Block Diagram. The inductor L acts as the receive coil, and together with the capacitance C, creates a resonant tank circuit. Power transmission across the weakly coupled link between the transmit coil and the receive coil (Figure 1) can be greatly improved when this tank circuit is tuned to the same frequency as the transmit coil AC current frequency.

### Receive Coil/Resonant Inductor L

The most important factor in selecting the receive coil is the quality factor of the coil:

$$Q_L = \frac{\omega_n L}{R_S}$$

where  $\omega_n$  is the operating resonant frequency in rad/s and  $R_S$  is the parasitic series resistance of the coil. Often this quality factor is limited by the size of the application. The smaller the size of the application, the harder it is to fit wire with small series resistance to generate higher inductance values. Therefore, in many cases, users are recommended to first consider the overall size of their end application and then decide on the biggest possible coil that fits this end application device.

Another commonly employed method to improve the Q value of the receive coil is the use of a ferrite core on the coil. Figure 8 shows a commonly employed ferrite core in the form of a sheet at both the  $T_X$  and  $R_X$  coils.

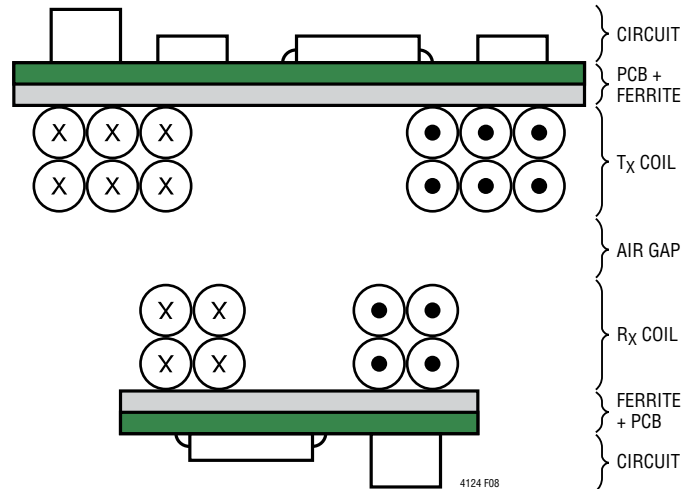

**Figure 8. Cross Section of  $T_X$  and  $R_X$  Coils with Ferrite Sheets**

The presence of this ferrite core increases the self-inductance value of each coil, which increases the Q. More importantly, proper placement of this ferrite material helps shape the magnetic field between the  $T_X$  and  $R_X$  coils which greatly improves the coupling or the mutual inductance between these two coils. Stronger coupling translates to better power transfer and higher efficiency.

Additionally this ferrite core helps shield the rest of the transmit and receive circuits which may be placed on the opposite side of the magnetic link (air gap in Figure 8). Table 7 lists some recommended inductors of different sizes for applications with the LTC4124.

**Table 7. Recommended Receive Coils**

Manufacturer	Part Number	Description
Würth Elektronik	760308101216	7.2 $\mu\text{H}$ , 6mm $\phi$
Würth Elektronik	760308101208	13 $\mu\text{H}$ , 10mm $\phi$
Würth Elektronik	760308101220	12.6 $\mu\text{H}$ , 17mm $\phi$



## APPLICATIONS INFORMATION

### Resonant Frequency Selection

As noted in the quality factor discussion of the receive coil, the higher the frequency of operation, the higher the quality factor of the coil. However, there are several limitations to setting the operating frequency to an arbitrarily high value.

The first is the self-resonant frequency of the coil. For the coils listed in Table 7, their self-resonant frequencies vary from 19MHz to 32MHz. The operating frequency should be set at least a factor of 5 below the coil self-resonant frequency so that this operating frequency can be well controlled by selecting the appropriate resonant capacitor value.

The second limitation is the transmitter circuit driver capability and efficiency. In most wireless power applications, the transmit circuit includes a DC to AC converter. The higher the operating frequency, the faster some elements of the transmit circuit need to switch. The speed at which these elements can be switched is often limited due to the architecture or process technology. Furthermore, a higher switching frequency lends itself to higher switching losses, which in turn reduces overall efficiency.

Therefore, as a guideline, the user should select a high operating frequency that is appropriate for the selected coils and transmitter circuit driver. The main trade-off is between the loss in efficiency of the transmitter circuit driver operating at higher frequency and the increase in coil to coil power transfer due to the higher Q of the coils. The LTC4124 is appropriate for systems with resonant frequencies anywhere from 50kHz up to 10MHz.

### Resonant Capacitor C

Once the coil and the operating frequency are selected, the value of the resonant capacitor is determined by the following formula:

$$C = \frac{1}{\omega_n^2 L}$$

where  $\omega_n$  is the operating resonant frequency in rad/s and L is the receive coil inductance. Select capacitors with low ESR and low thermal coefficients such as COG or X7R

ceramic. In general, the higher the voltage rating of the capacitor, the lower the dissipation factor of its dielectric material but also the larger the size would be. The dissipation factor of a capacitor includes the ESR as one of its main components. Note that this dissipation factor is not usually listed in a standard capacitor data sheet.

Table 8 lists some recommended capacitors of different sizes for applications with the LTC4124.

**Table 8. Recommended Resonant Capacitors**

Manufacturer	Part Number	Description
Murata	GRM155R71H332JA01D	50V, 0402, 3.3nF
Murata	GRM155R71H683KE14J	50V, 0402, 68nF
Murata	GRM155R71H333KE14D	50V, 0402, 33nF
TDK	CGA4J2C0G1H333J125AA	50V, 0805, 33nF

### Choosing Transmit Power Level

The transmit power level should be set as low as possible for the receiver to receive the desired output power under the worst-case coupling conditions (i.e. maximum transmit distance with the worst-case alignment). Although the LTC4124 is capable of shunting excess received power to maintain the  $V_{CC}$  voltage in the desired range, its temperature will rise when shunting excess power. Careful evaluation of the application needs to be performed to ensure that the operating temperature range of the LTC4124 and the end application is not exceeded.

Empirically, the determination of transmit power level of the application circuit can be done by first setting the transmit inductor current at the highest rated current possible based on the transmit coil specification. From this starting point, transmit power can then be adjusted lower until the charge current of the LTC4124 on the receive side is negatively impacted under worst-case coupling conditions. Once this minimum transmit power level is determined, the transmit and receive coils should be arranged under best-case coupling conditions with a fully charged battery to make sure that the shunting of excess power by the LTC4124 does not raise its temperature too much.

In addition to temperature, another parameter that needs to be checked is the maximum negative voltage on the

## APPLICATIONS INFORMATION

ACIN pin. Following the procedure above, when evaluating the rise in temperature of the LTC4124 under the best-case coupling conditions, ensure that  $V_{VCC} - V_{ACIN}$  does not exceed 40V. Figure 9 shows a typical waveform on ACIN showing  $V_{CC} - V_{ACIN} < 40V$ .

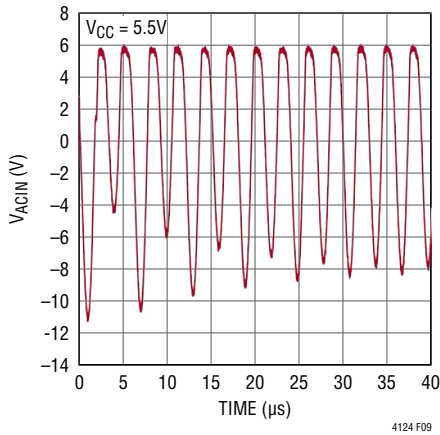

**Figure 9. Typical Acceptable Voltage Waveform on the ACIN pin with  $V_{CC} - V_{ACIN} < 40V$ .**

As an alternative to using the empirical method to determine the maximum negative voltage on the ACIN pin, the following formula can be used in conjunction with Figure 10, which shows a parallel resonant configuration on the receiver:

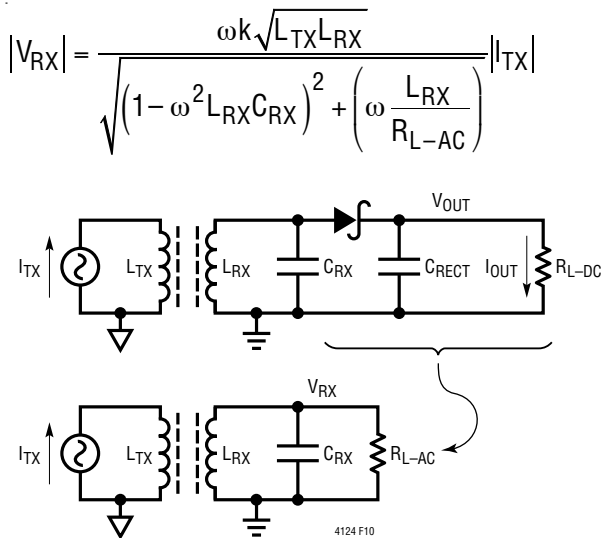

**Figure 10. Modeling Parallel Resonant Configuration and Half Wave Rectifier on the Receiver**

$|V_{RX}|$  is the amplitude of the voltage on the receiver coil,  $|I_{TX}|$  is the amplitude of the current in the transmit coil,  $k$  is the coupling factor between the transmit and receive coils,  $\omega$  is the operating frequency in radians per second,  $L_{TX}$  is the self-inductance of the transmit coil,  $L_{RX}$  is the self-inductance of the receive coil,  $C_{RX}$  is the receiver resonant capacitance, and  $R_{L-AC}$  is the equivalent AC load resistance.

One simplification is as follows:

$$R_{L-AC} \approx \frac{R_{L-DC}}{2}$$

which assumes that the drop across the Schottky diode is much smaller than the amplitude  $|V_{RX}|$ . Additionally,  $R_{L-DC}$  can be approximated as the ratio of the output voltage ( $V_{OUT}$ ) to the output current ( $I_{OUT}$ ):

$$R_{L-DC} = \frac{V_{OUT}}{I_{OUT}}$$

The amplitude of the current in the transmit coil  $|I_{TX}|$  can be either measured directly or its initial (no receiver) value can be calculated based on the transmitter circuit as described in the applications example. This initial value is a conservative estimate since the amplitude of the transmitter coil current will drop as soon as the receiver, with a load, is coupled to it.

The coupling factor ( $k$ ) between the two coils could be obtained by running a finite element simulation inputting the coil dimensions and physical configurations. An easier method to obtain this coupling number, is to use the series-aiding and series-cancelling empirical measurement method for two loosely coupled coils as shown in Figure 11.

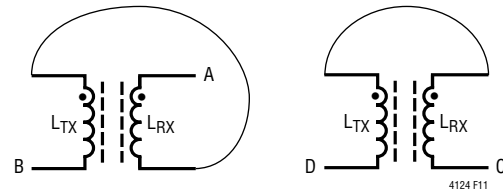

**Figure 11. Series-Aiding and Series-Cancelling Method Configurations Used for Measuring the Coupling Factor  $k$**



## APPLICATIONS INFORMATION

And:

$$L_{\text{AIDING}} = L_{\text{AB}}$$

$$L_{\text{CANCELLING}} = L_{\text{CD}}$$

$$k = \frac{L_{\text{AIDING}} - L_{\text{CANCELLING}}}{4\sqrt{L_{\text{TX}}L_{\text{RX}}}}$$

### PC BOARD LAYOUT CONSIDERATIONS

Since the exposed pad of the LTC4124 package is the only ground connection and serves as the return path for both the charger and the DC/DC converter, it must be soldered

to the PC board ground for a good electrical connection. The shunt circuitry in the Wireless Power Manager block (Functional Block Diagram) dissipates some power within the IC that may cause the die temperature to rise. For optimum thermal performance, there should be a group of vias directly under the exposed pad on the backside leading directly down to a ground plane on layer 2.

Figure 12 shows a recommended layout of a complete LTC4124 application PC Board. The diameter of this general purpose board, which allows for all permutations for the pin programmable settings, is only 5.2mm.

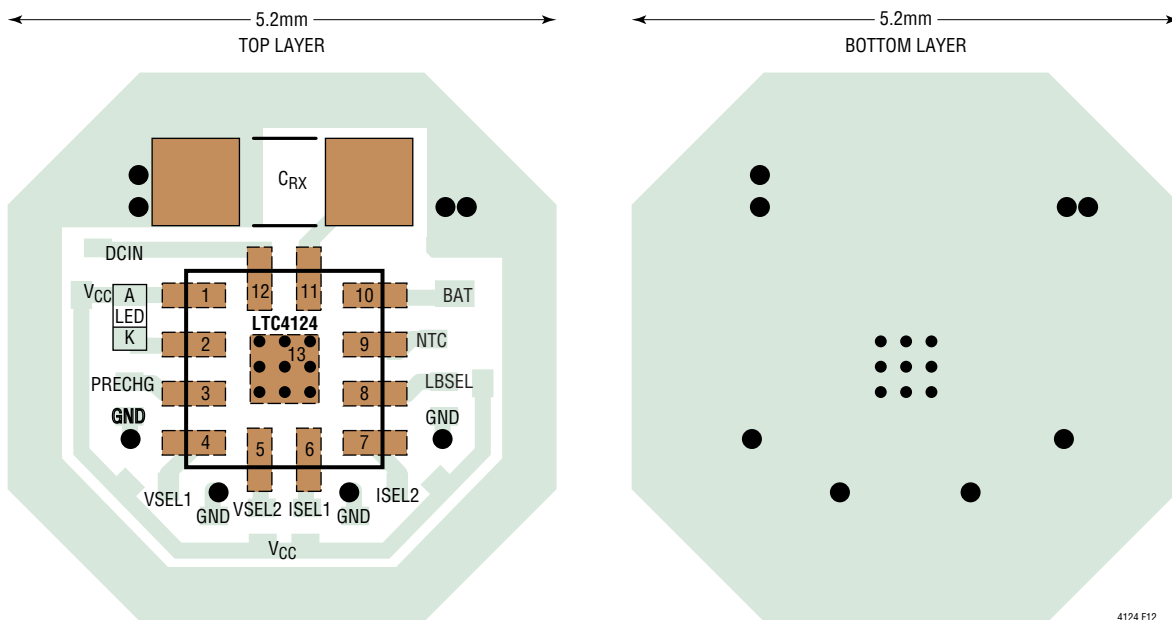

Figure 12. Recommended Minimum Footprint Layout

## APPLICATIONS INFORMATION

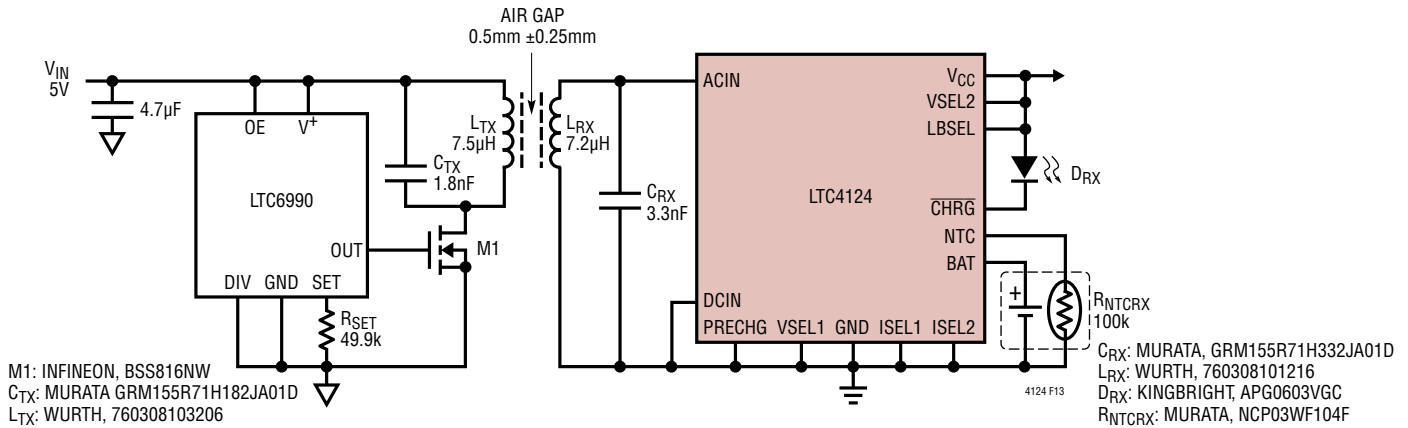

Figure 13. Single Transistor Transmitter and LTC4124 10mA Charger Receiver

### DESIGN EXAMPLE 1: SINGLE TRANSISTOR TRANSMITTER AND LTC4124 10mA CHARGER RECEIVER

The single transistor transmitter shown in Figure 13 is an example of a DC/AC converter that can be used to drive AC current into a transmit coil,  $L_{TX}$ . NMOS switch M1 is driven by a 50% duty cycle square wave generated by the LTC6990 oscillator. During the first half of the cycle, M1 is on and the current through  $L_{TX}$  rises linearly. During the second half of the cycle, M1 is off and the current through  $L_{TX}$  circulates through the LC tank formed by  $C_{TX}$  and  $L_{TX}$ . The current through  $L_{TX}$  is shown in Figure 14.

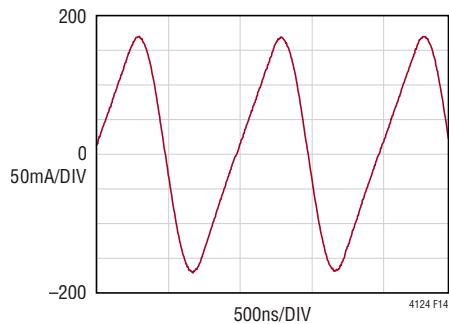

Figure 14. Current Through Transmit Coil

If the transmit LC tank frequency is set to 1.29 times the driving frequency, switching losses in M1 are significantly reduced due to zero voltage switching (ZVS). Figure 15 and Figure 16 illustrate the contrast in the switching waveforms when the tank frequency is set at different values.

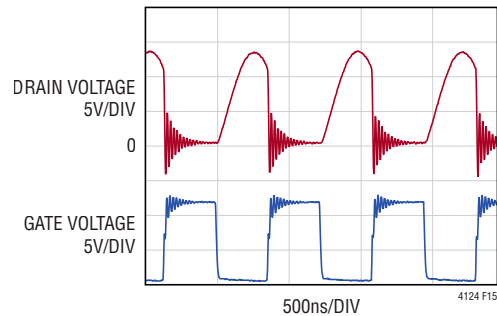

Figure 15. Voltage on the Drain and Gate of NMOS M1 when  $f_{TX-TANK} = f_{DRIVE}$

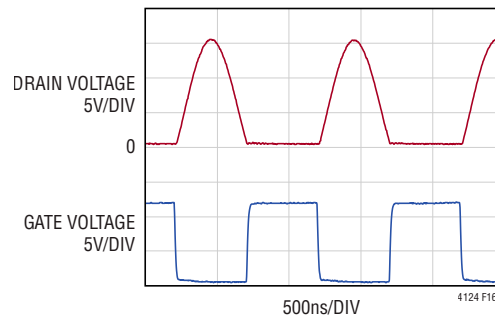

Figure 16. Voltage on the Drain and Gate of NMOS M1 when  $f_{TX-TANK} = 1.29 \cdot f_{DRIVE}$

## APPLICATIONS INFORMATION

Therefore, the ZVS condition is achieved when the following condition is satisfied:

$$f_{TX-TANK} = 1.29 \cdot f_{DRIVE}$$

where  $f_{DRIVE}$  is set by resistor  $R_{SET}$  connected to the LTC6990.  $f_{TX-TANK}$  is set by:

$$f_{TX-TANK} = \frac{1}{2\pi\sqrt{L_{TX} \cdot C_{TX}}}$$

The peak voltage of the transmit coil,  $L_{TX}$ , that appears at the drain of M1 is:

$$V_{TX-PEAK} = 1.038 \cdot \pi \cdot V_{IN}$$

And the peak current through  $L_{TX}$  is:

$$I_{TX-PEAK} = \frac{0.36 \cdot V_{IN}}{f_{TX-TANK} \cdot L_{TX}}$$

The RMS current through  $L_{TX}$  is:

$$I_{TX-RMS} = 0.66 \cdot I_{TX-PEAK}$$

The LC tank at the receiver,  $L_{RX}$  and  $C_{RX}$ , is tuned to the same frequency as the driving frequency of the transmit LC tank:

$$f_{RX-TANK} = f_{DRIVE}$$

where  $f_{RX-TANK}$  is given by:

$$f_{RX-TANK} = \frac{1}{2\pi\sqrt{L_{RX} \cdot C_{RX}}}$$

Note that since  $f_{DRIVE}$  can be easily adjusted by changing the value of  $R_{SET}$ , it is best practice to choose  $f_{RX-TANK}$  using the minimum component count (i.e. standard value for  $C_{RX}$ ) and then adjusting  $f_{DRIVE}$  to match. The receiver resonant frequency can be selected using the guideline described in the resonant frequency selection section.

The amount of AC current in the transmit coil can be increased by increasing the supply voltage ( $V_{IN}$ ). Since the amount of power transmitted is proportional to the AC current in the transmit coil,  $V_{IN}$  can be varied to adjust the power delivery to the receive coil. When adjusting the supply voltage, care needs to be taken that the absolute maximum voltage rating of the LTC6990 pins as well as the maximum drain to source voltage rating of NMOS M1 are not exceeded.

The steps needed to determine each of the component values for the circuit shown in Figure 13 are reviewed here:

1. Determine the receiver resonant frequency and set component values for the receiver LC tank:

As discussed in previous sections, the resonant frequency should be selected such that it is at least a factor of 5 below the self-resonant frequency of the coils and within the capability of the transmitter driver circuit. In this example, the self-resonant frequency of the  $R_X$  coil is 32MHz and the  $T_X$  coil is 23MHz. So a factor of 5 below 23MHz is 4.6MHz.

The transmitter driver circuit in this example is the LTC6990 driving an N-Channel MOSFET from Infineon (BSS816NW). This particular MOSFET has a total gate charge ( $Q_g$ ) of 600pC. The output driver resistance of the LTC6990 is 150Ω. Therefore, the expected time constant of the waveform on the gate of the MOSFET is 90ns. In order for the rise and fall times of the waveform not to take more than 20% of the total waveform period, the maximum switching frequency of this waveform should be about 1MHz.

It is best practice to select a resonant frequency that yields a low component count on the receiver to ensure the smallest footprint in an often space-constrained receiver device.

In this example, 1MHz is selected as the receiver resonant frequency. At 1MHz, the tank capacitance ( $C_{RX}$ ) required with the selected receive coil (7.2μH) is 3.3nF. Since 3.3nF is a standard value for capacitors, the tank capacitance requires only one component. The tank capacitance calculation is shown below.

$$C_{RX} = \frac{1}{4 \cdot \pi^2 \cdot f_{RX-TANK}^2 \cdot L_{RX}} = 3.5nF \approx 3.3nF$$

Following the guidance on selecting the resonant capacitor, select a 3.3nF capacitor with the highest voltage rating while keeping the footprint to an acceptable size. In this particular example, a 3.3nF capacitor with a 25V voltage rating and a small 0603 footprint is chosen.

## APPLICATIONS INFORMATION

2. Set the driving frequency ( $f_{DRIVE}$ ) for the single transistor transmitter:

$f_{DRIVE}$  is set to the same value as the receiver resonant frequency:

$$R_{SET} = \frac{1\text{MHz}}{f_{OUT}} \cdot \frac{50\text{k}\Omega}{N_{DIV}} = \frac{1\text{MHz}}{1\text{MHz}} \cdot \frac{50\text{k}\Omega}{1} = 50\text{k}\Omega$$

where  $N_{DIV} = 1$  as the DIV pin of the LTC6990 is grounded. Select a 49.9k $\Omega$  (standard value) resistor with 1% tolerance. For more information regarding the oscillator, consult the LTC6990 data sheet.

3. Set the LC tank component values for the single transistor transmitter: If  $f_{DRIVE}$  is 1MHz, the transmit LC tank frequency ( $f_{TX-TANK}$ ) is:

$$f_{TX-TANK} = 1.29 \cdot 1\text{MHz} = 1.29\text{MHz}$$

The transmit coil ( $L_{TX}$ ) used in this example is 7.5 $\mu\text{H}$ . The value of transmit tank capacitance ( $C_{TX}$ ) can be calculated:

$$C_{TX} = \frac{1}{4 \cdot \pi^2 \cdot f_{TX-TANK}^2 \cdot L_{TX}} = 2.0\text{nF}$$

Accounting for the parasitic capacitance on the drain of M1, a  $C_{TX}$  value of 1.8nF is chosen. The recommended rating for  $C_{TX}$  capacitors is 50V with 5% (or better) tolerance.

4. Verify that the AC current through the transmit coil is well within its rating. In this example, the supply voltage to the single transistor transmitter is 5V. The peak AC current through the transmit ( $L_{TX}$ ) coil can be calculated as:

$$I_{TX-PEAK} = \frac{0.36 \cdot V_{IN}}{f_{TX-TANK} \cdot L_{TX}} = \frac{0.36 \cdot 5\text{V}}{1.29 \times 10^6 \cdot 7.5\mu\text{H}}$$

$$I_{TX-PEAK} = 0.19\text{A}$$

and the RMS current as:

$$I_{TX-RMS} = 0.66 \cdot 0.19\text{A} = 0.13\text{A}$$

The  $I_{TX-RMS}$  is well below the 1.55A max rated current for the transmit coil (see the Würth Elektronik 760308103206 data sheet for more information).

5. Also verify that the transmit power level chosen does not result in excessive heating nor excessive negative voltage on the ACIN pin of the LTC4124.

Using the guidelines described in the Choosing Transmit Power Level section, the transmit and receive coils should be arranged under best-case coupling conditions with a fully charged battery, and the steady state temperature of the LTC4124 should then be measured. Additionally,  $V_{VCC} - V_{ACIN}$  should also be verified.

The best coupling condition typically occurs with the smallest air gap between the coils and the two coils in a concentric arrangement. However in this particular example, the transmit coil shape is elliptical. Figure 17 shows the 2D physical arrangement resulting in best-coupling conditions for the two coils in this example.

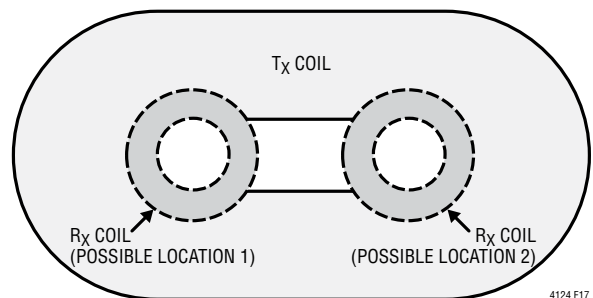

**Figure 17. Best Coupling Condition for the Coils in Design Example 1**

If we set the air gap to 0mm minimum, the maximum temperature rise of the LTC4124 is 12°C and the maximum  $V_{VCC} - V_{ACIN}$  is 13V.

This result is verified using the alternative formula provided in the Choosing Transmit Power Level section. Using the suggested method, the coupling value at the best coupling condition is 0.04. Using this coupling value, the predicted value of the minimum negative voltage developed on the ACIN is -8V. Therefore, the predicted maximum  $V_{VCC} - V_{ACIN}$  is 13V as verified empirically.

## APPLICATIONS INFORMATION

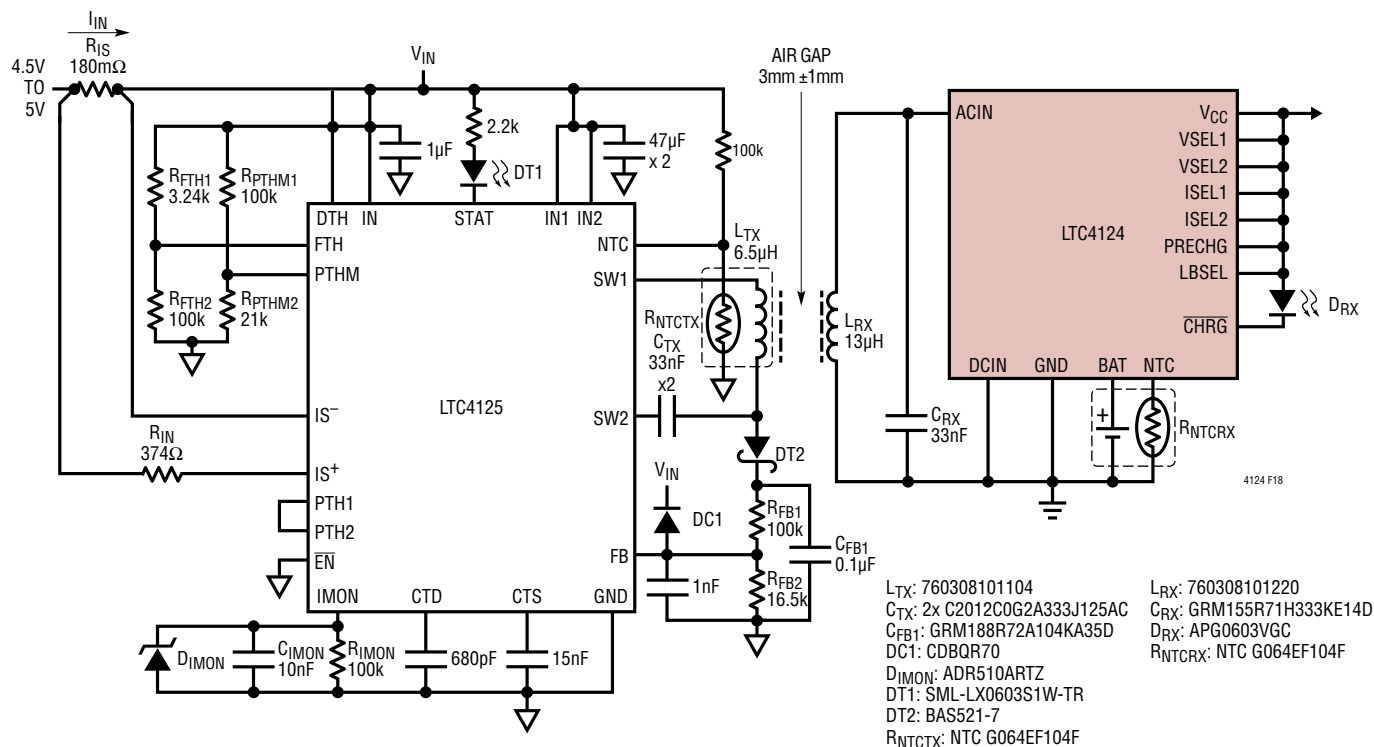

Figure 18. LTC4124 100mA Charger Receiver with LTC4125 AutoResonant Transmitter

## DESIGN EXAMPLE 2: LTC4124 100mA CHARGER RECEIVER WITH LTC4125 AutoResonant® TRANSMITTER

Figure 18 shows a complete schematic of a wireless battery charger application showcasing the LTC4124 charging at 100mA. The transmitter circuit uses the LTC4125 AutoResonant Wireless Power Transmitter IC.

The LTC4125 drives a series LC network connected to its switch pins at its resonant frequency. The LTC4125 auto resonant drive ensures that the voltage across its SW1 and SW2 pins is always in phase with the current in the transmitter series LC network as shown in Figure 19.

The LTC4125 also pulse width modulates the voltage across its SW1 and SW2 pins in order to control the amount of transmit coil current. Figure 20 shows the transmitter LC tank current and voltage waveforms when the drive pulse width results in a duty cycle less than 50%.

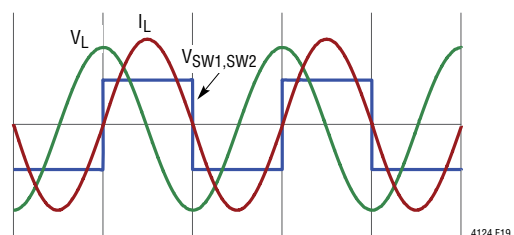
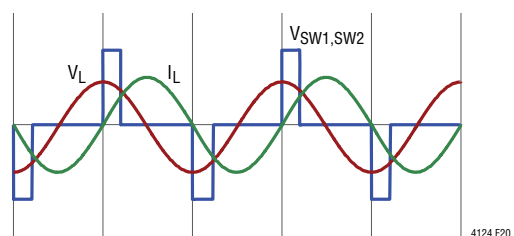
Figure 19. Transmitter Series LC Tank Voltage and Current Waveforms with  $V_{sw1,sw2}$  at 50% Duty CycleFigure 20. Transmitter Series LC Tank Voltage and Current Waveforms with  $V_{sw1,sw2}$  at Less Than 50% Duty Cycle

## APPLICATIONS INFORMATION

The LTC4125 also features the ability to sense the load at the receiver which allows it to go to a low power operating state in the absence of a receiver. Furthermore, it has a foreign object detection feature which prevents inadvertent wireless transmission of power to a conductive foreign object. Refer to the LTC4125 data sheet for more details on the LTC4125 operation and applications.

The steps needed to determine each of the component values for the circuit shown in Figure 18 are reviewed here:

1. Determine the receiver resonant frequency and set component values for the receiver LC tank:

Similar to the first design example, the resonant frequency should be selected such that it is at least a factor of 5 below the self-resonant frequency of the coils and within the capability of the transmitter driver circuit. In this example, the self-resonant frequency of the  $R_X$  coil is 19MHz and of the  $T_X$  coil is 20MHz. So a factor 5 below 19MHz is 3.8MHz.

The LTC4125 transmitter IC has a maximum switching frequency of 320kHz. It is best practice to select a resonant frequency that yields a low component count on the receiver to ensure the smallest footprint.

In this example, 240kHz is selected as the receiver resonant frequency. At 240kHz, the tank capacitance ( $C_{RX}$ ) required with the selected receive coil (13 $\mu$ H) is 33nF.

Following the guidance on selecting the resonant capacitor, in this particular example a 33nF capacitor with a 50V voltage rating and a small 0402 footprint is chosen.

2. Set the transmitter LC tank component values to match the receiver resonant frequency.

The transmit LC tank frequency ( $f_{TX-TANK}$ ) is also set at 240kHz. The transmit coil ( $L_{TX}$ ) used in the example is 6.5 $\mu$ H. The value of transmit tank capacitance ( $C_{TX}$ ) can be calculated:

$$C_{TX} = \frac{1}{4 \cdot \pi^2 \cdot f_{TX-TANK}^2 \cdot L_{TX}} = 66\text{nF}$$

The recommended rating for  $C_{TX}$  capacitors in this particular example is 100V with 5% (or better) tolerance.

3. Determine the minimum pulse width of the transmitter driver required to deliver the required power at the receiver under the worst-case coupling conditions with maximum load.

With  $L_{RX}$ ,  $C_{RX}$ ,  $L_{TX}$  and  $C_{TX}$  as determined above, place the receiver circuit in the worst-case coupling condition (largest gap between the  $T_X$  and  $R_X$  coils) with the battery at 4.1V (highest battery voltage in CC mode  $\rightarrow$  highest output power). In this particular example, the worst-case coupling condition is set to be a 5.5mm separation with the two coils placed in a concentric configuration. Measure  $I_{IN}$  and  $I_{BAT}$  while varying the DC voltage on the PTH pins ( $V_{PTH}$ ) of the transmitter. Figure 21 shows the plot of these measurements for this particular example.

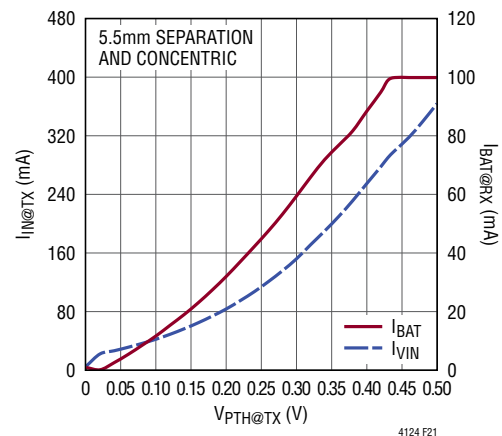

Figure 21.  $I_{IN}$  and  $I_{BAT}$  vs  $V_{PTH}$

From Figure 21, the minimum voltage required at  $V_{PTH}$  ( $V_{PTHM}$ ) for the receiver to have the full charge current is 0.43V. This corresponds to 13% duty cycle at the driving voltage across the switch pins of the transmitter circuit.



## APPLICATIONS INFORMATION

4. Verify that at the minimum pulse width selected in Step 3, the AC current through the transmit coil is well within its rating and that there is no excessive heating on the LTC4124 nor excessive negative voltage on the ACIN pin of the LTC4124.

With the minimum pulse width determined in the previous step, place the receiver circuit at the best-case coupling condition (In this particular example, the best coupling condition is set to be 1.5mm separation with the  $T_X$  and  $R_X$  coils placed in a concentric configuration.) with the battery pin set at 4.3V (zero charge current  $\rightarrow$  lowest output power). Measure  $I_{L-TX(RMS)}$ ,  $\Delta T_{LTC4124}$  and  $V_{ACIN-MIN}$ . With  $V_{PTH} = 0.43V$  (from the previous step) and  $V_{BAT} = 4.3V$ , at the best-case coupling condition and steady state, the measured parameters are as follows:

$I_{L-TX(RMS)} = 1.0A$ ,  $\Delta T_{LTC4124} = 32^\circ C$  and  $V_{ACIN-MIN} = -8.5V$ . The  $I_{L-TX(RMS)}$  is well below the 2.5A max rated current for the transmit coil (see the Würth Elektronik 760308101104 data sheet for more information). The temperature rise of  $32^\circ C$  and the minimum negative voltage on the ACIN pin are well within the rated operating condition for the LTC4124.

This result is verified using the alternative formula provided in the Choosing Transmit Power Level section. Using the suggested method, the coupling value at the best coupling condition is 0.5. Using this coupling value, the predicted value of the minimum negative voltage developed on the ACIN is  $-8.5V$ . Therefore, the predicted maximum  $V_{VCC} - V_{ACIN}$  is 14V as verified empirically.

5. Determine the values of  $R_{PTHM1}$  and  $R_{PTHM2}$  based on the minimum pulse width of the transmitter driver obtained in Step 3.

Set  $R_{PTHM1} = 100k\Omega$ .  $R_{PTHM2}$  can be obtained using the following formula:

$$R_{PTHM2} = \frac{\left\lfloor \frac{32 \cdot V_{PTHM}}{2.4} \right\rfloor + 0.5}{32 - \left( \left\lfloor \frac{32 \cdot V_{PTHM}}{2.4} \right\rfloor + 0.5 \right)} \cdot R_{PTHM1}$$

$$= 20.8k\Omega$$

$$\approx 21k\Omega \text{ (standard 1% resistor value)}$$

Note the quantity in the floor function brackets should be rounded down to the nearest integer.

6. Determine the values of  $R_{IS}$ ,  $R_{IN}$ ,  $R_{IMON}$  and  $C_{IMON}$  for load detection at best coupling with minimum load.

With the same setup used in Step 4 and  $V_{BAT} = 4.3V$ , the input current to the transmit board is measured as  $I_{IN} = 240mA$  ( $I_{TH}$ ). With the voltage drop across the sense resistor  $R_{IS}$  set to about 40mV, calculate  $R_{IS}$  according to the following formula:

$$R_{IS} = \frac{40mV}{I_{IN}} = \frac{40mV}{240mA} = 167m\Omega$$

$$\approx 180m\Omega \text{ (standard 1% sense resistor value)}$$

$R_{IN}$  is set to be  $374\Omega$  such that with 40mV across  $R_{IS}$ , the IMON pin will source  $107\mu A$ . This source current biases  $D_{IMON}$  to generate 1V at the IMON pin for load detection.  $C_{IMON}$  is set to be 10nF to provide some filtering on the IMON pin voltage, and  $R_{IMON}$  is set to  $100k\Omega$  to discharge  $C_{IMON}$  when the source current on the IMON pin is not present.

## APPLICATIONS INFORMATION

7. Determine the value of  $C_{TS}$  for step duration during the LTC4125 load detection.

Set the step duration to 50ms, approximately about 5 times the observed  $V_{IMON}$  settling time.

$$C_{TS} = 5 \cdot \frac{10\mu A \cdot T_S}{32 \cdot 1.2V} = 1.3 \times 10^{-6} \cdot T_S (s)$$

$$\approx 15nF \text{ (standard capacitor value)}$$

8. Determine the value of  $R_{FB1}$  and  $R_{FB2}$  for no receiver detection.

With the minimum pulse width as determined in Step 3 and no receiver, measure  $I_{IN}$  and  $V_{LC-TX}$  amplitude. In this particular example, with no  $R_X$  present, at  $V_{PTH} = 0.43V$ :  $I_{IN} = 580mA$  and  $|V_{LC-TX}| = 40V$ .

The same measurement is done with a receiver at the worst coupling condition (largest gap between the  $T_X$  and  $R_X$  coils) with the battery pin set at 4.3V (zero charge current  $\rightarrow$  lowest output power). In this particular example, using setup 4 at  $V_{PTH} = 0.43V$ ,  $I_{IN} = 450mA$  and  $|V_{LC-TX}| = 25V$ .

At the  $V_{PTH}$  determined in step 3, the voltage at the transmitter resonant tank with no receiver is 40V ( $V_{LC-TX-MAX}$ ), and with a receiver at minimum load, it is 25V ( $V_{LC-TX-MIN}$ ). Using the formula provided in the LTC4125 data sheet,  $R_{FB1}$  and  $R_{FB2}$  can be calculated as follows:

$$\frac{V_{LC-TX-MIN} - V_D}{V_{IN}} - 1 < \frac{R_{FB1}}{R_{FB2}} < \frac{V_{LC-TX-MAX} - V_D}{V_{IN}} - 1$$

$$\frac{25V - 1V}{5V} - 1 < \frac{R_{FB1}}{R_{FB2}} < \frac{40V - 1V}{5V} - 1$$

$$3.8 < \frac{R_{FB1}}{R_{FB2}} < 6.8$$

Therefore, set the ratio to be 6. Since the recommended total  $R_{FB1} + R_{FB2}$  resistance is about  $100k\Omega$ , set  $R_{FB1} = 100k\Omega$  and  $R_{FB2} = 16.5k\Omega$ .

9. Determine the value of  $R_{FTH1}$  and  $R_{FTH2}$  for foreign object detection.

As outlined in steps 1 and 2, the resonant frequency selected is 240kHz. However, the operating frequency of the two coupled resonant LC at the  $T_X$  and  $R_X$  under heavy load at the best coupling condition is as high as 300kHz. Therefore, set the foreign object detection frequency threshold at 310kHz, about 3% above the highest operating frequency. Set  $R_{FTH2} = 100k\Omega$  and  $R_{FTH1}$  according to the following formula:

$$R_{FTH1} = \left( \frac{320kHz}{f_{LIM}} - 1 \right) \cdot R_{FTH2}$$

$$= \left( \frac{320kHz}{310kHz} - 1 \right) \cdot 100k\Omega = 3.23k\Omega$$

$$\approx 3.24k\Omega \text{ (standard 1% resistor value)}$$

10. Determine the value of  $C_{TD}$  for the delay between each load detection attempt.

Set the wait time to 5 seconds. Then, the  $C_{TD}$  value is calculated using the following formula:

$$C_{TD} = \frac{10\mu A \cdot T_D}{65 \times 10^3 \cdot 1.2V} = 1.3 \times 10^{-10} \cdot 5 \approx 680pF$$



## TYPICAL APPLICATIONS

### 25mA LTC4124 Charger Receiver Using a 10mm R<sub>x</sub> Coil Paired with a Simple Single Transistor Transmitter

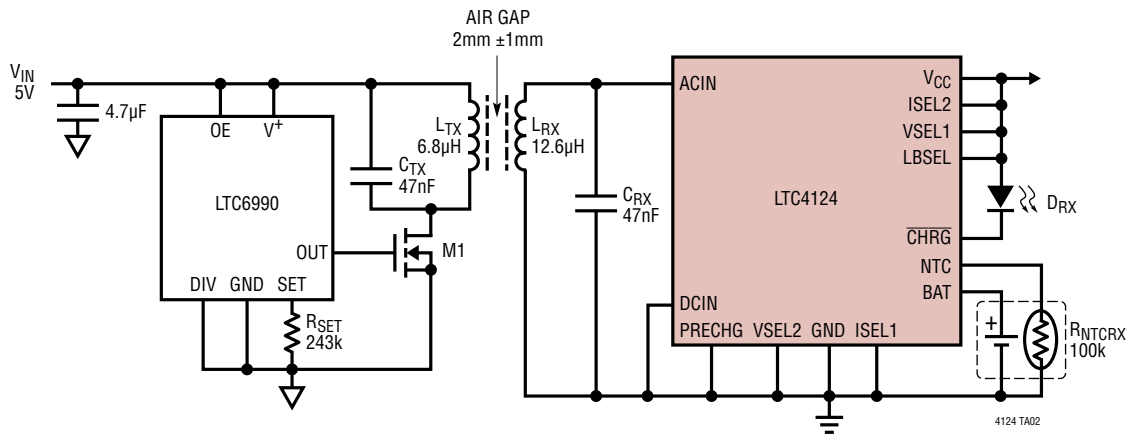

M1: INFINEON, BSS816NW  
 CTX: MURATA GCJ188R92A473KA01D  
 LTX: WURTH, 760308101104

CRX: MURATA, GCM155R71H473KE02J  
 LRX: WURTH, 760308101208  
 DRX: KINGBRIGHT, APG0603VGC  
 RNTCRX: MURATA, NCP03WF104F

## 50mA LTC4124 Charger Receiver Paired with LTC4125 AutoResonant Transmitter

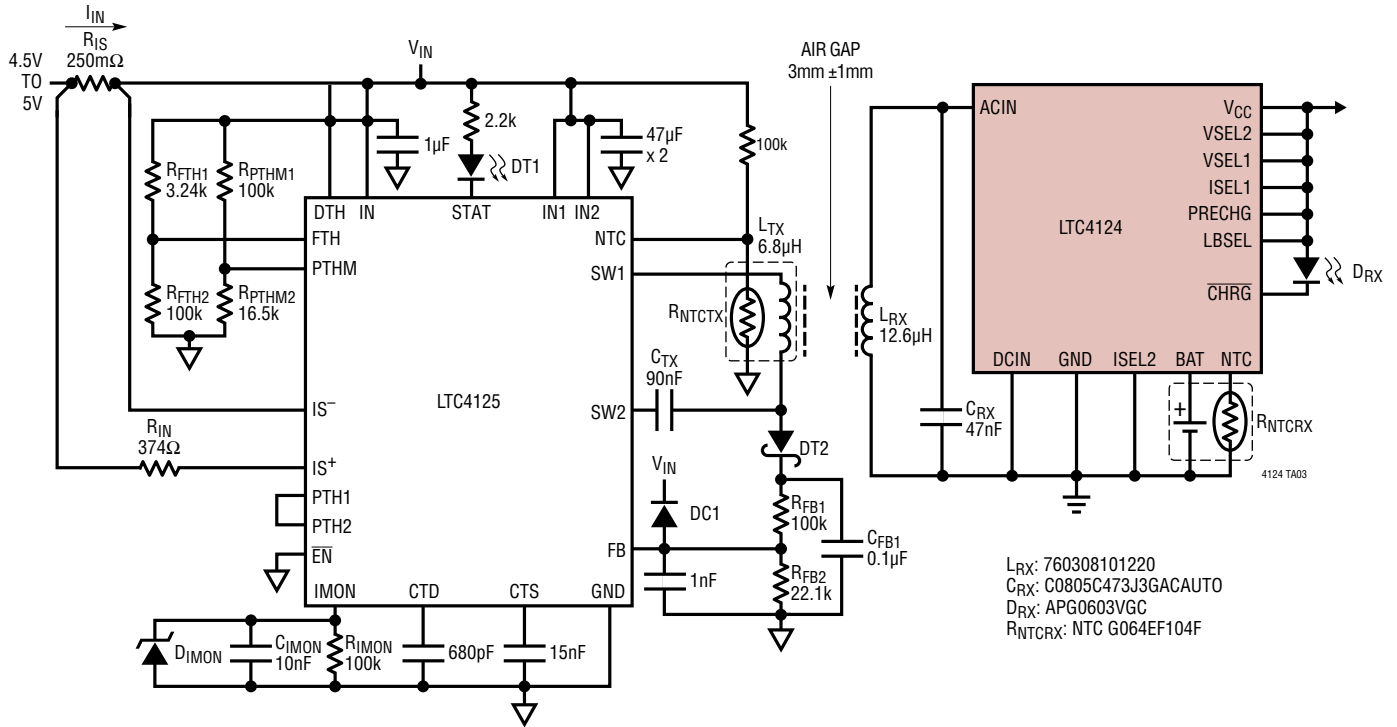

$L_{TX}$ : 760308101104  
 $C_{TX}$ : C3216C0G1H683J160AA, C3216C0G1H223J060AA  
 $C_{FB1}$ : GRM188R72A104KA35D  
 $DC1$ : CDBQR70  
 $D_{IMON}$ : ADR510ARTZ  
 $DT1$ : SML-LX0603S1W-TR  
 $DT2$ : BAS521-7  
 $R_{NTCTX}$ : NTC G064EF104F

$L_{RX}$ : 760308101220  
 $C_{RX}$ : C0805C473J3GACAUTO  
 $DRX$ : APG0603VGC  
 $R_{NTCRX}$ : NTC G064EF104F

# TYPICAL APPLICATIONS

**100mA Charger Receiver Paired with LTC4125 AutoResonant Transmitter in Optimum Power Search Operation (LTC4125 Configured as Half-Bridge Resonant Driver)**

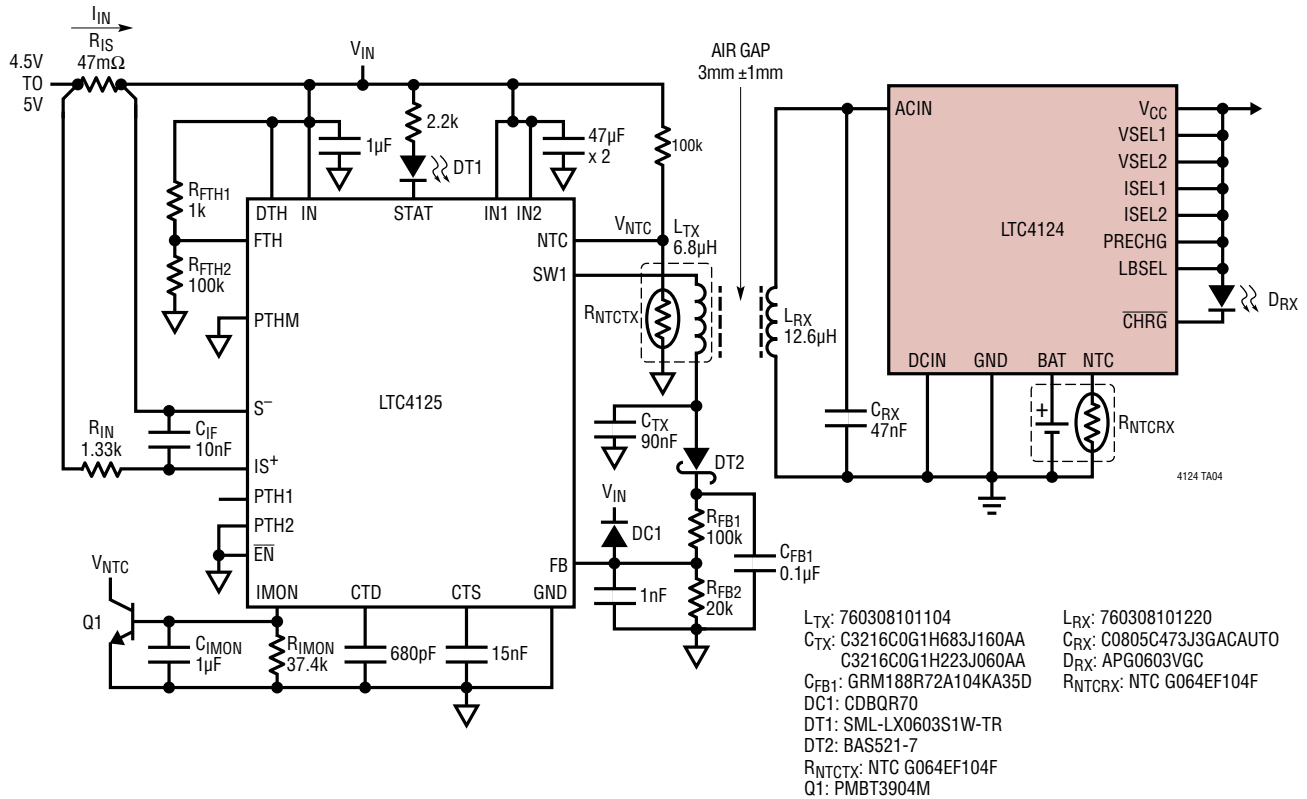

PACKAGE DESCRIPTION

**LQFN Package**  
**12-Lead (2mm × 2mm × 0.74mm)**  
 (Reference LTC DWG # 05-08-1530 Rev B)

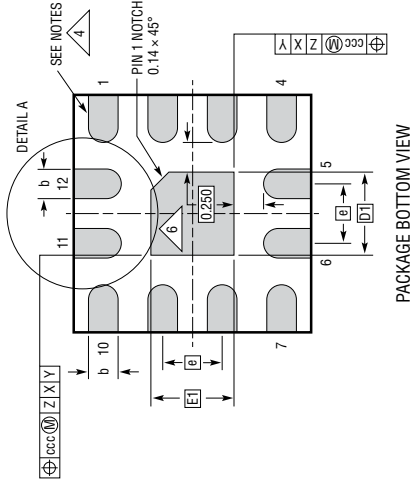

- NOTES:
1. DIMENSIONING AND TOLERANCING PER ASME Y14.5M-1994
  2. ALL DIMENSIONS ARE IN MILLIMETERS
  3. PRIMARY DATUM - Z - IS SEATING PLANE
  4. METAL FEATURES UNDER THE SOLDER MASK OPENING NOT SHOWN SO AS NOT TO OBSCURE THESE TERMINALS AND HEAT FEATURES
  5. DETAILS OF PIN 1 IDENTIFIER ARE OPTIONAL, BUT MUST BE LOCATED WITHIN THE ZONE INDICATED. THE PIN 1 IDENTIFIER MAY BE EITHER A MOLD OR MARKED FEATURE
  6. THE EXPOSED HEAT FEATURE MAY HAVE OPTIONAL CORNER RADI

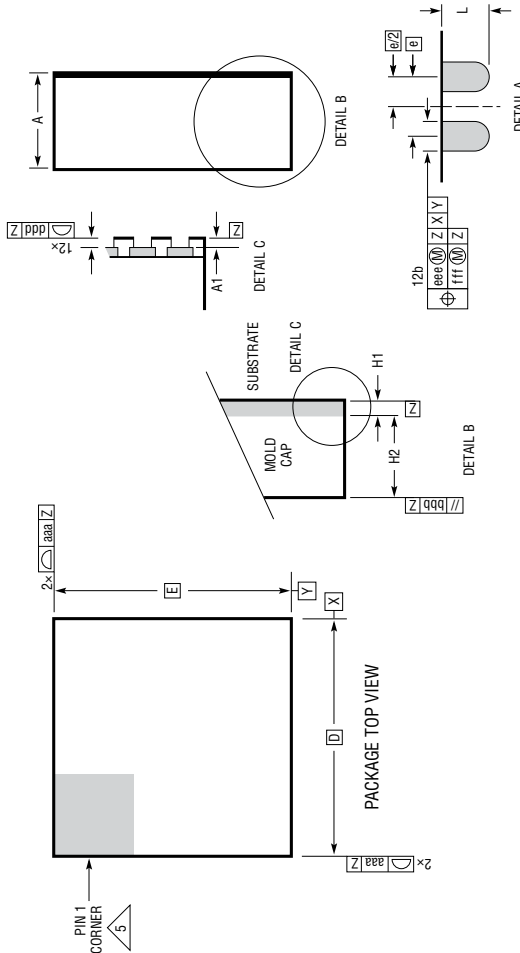

SYMBOL	DIMENSIONS			NOTES
	MIN	NOM	MAX	
A	0.65	0.74	0.83	
A1	0.01	0.02	0.03	
L	0.30	0.40	0.50	
b	0.22	0.25	0.28	
D		2.00		
E		2.00		
D1		0.70		
E1		0.70		
e		0.50		
H1		0.24 REF		SUBSTRATE THK
H2		0.50 REF		MOLD CAP HT
aaa			0.10	
bbb			0.10	
ccc			0.10	
ddd			0.10	
eee			0.15	
fff			0.08	

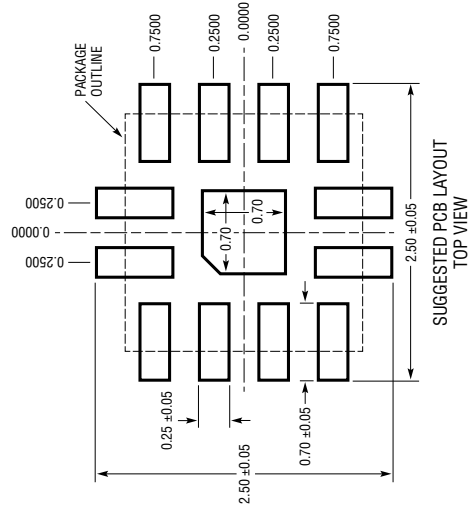

LQFN12.0616 REV B

## REVISION HISTORY

REV	DATE	DESCRIPTION	PAGE NUMBER
A	11/19	Changed Battery Charging $V_{UVCL}$ Condition	3
		Changed Battery Discharge PowerPath Forward Regulation Voltage Condition	4
		Changed Disconnect Battery Leakage Curve Conditions	5
		Changed Application Circuits Cap Values	26, 27

## TYPICAL APPLICATION

Up to Four LTC4124, 10mA Minimum Size Charger Receivers with a Single LTC4125 AutoResonant Transmitter

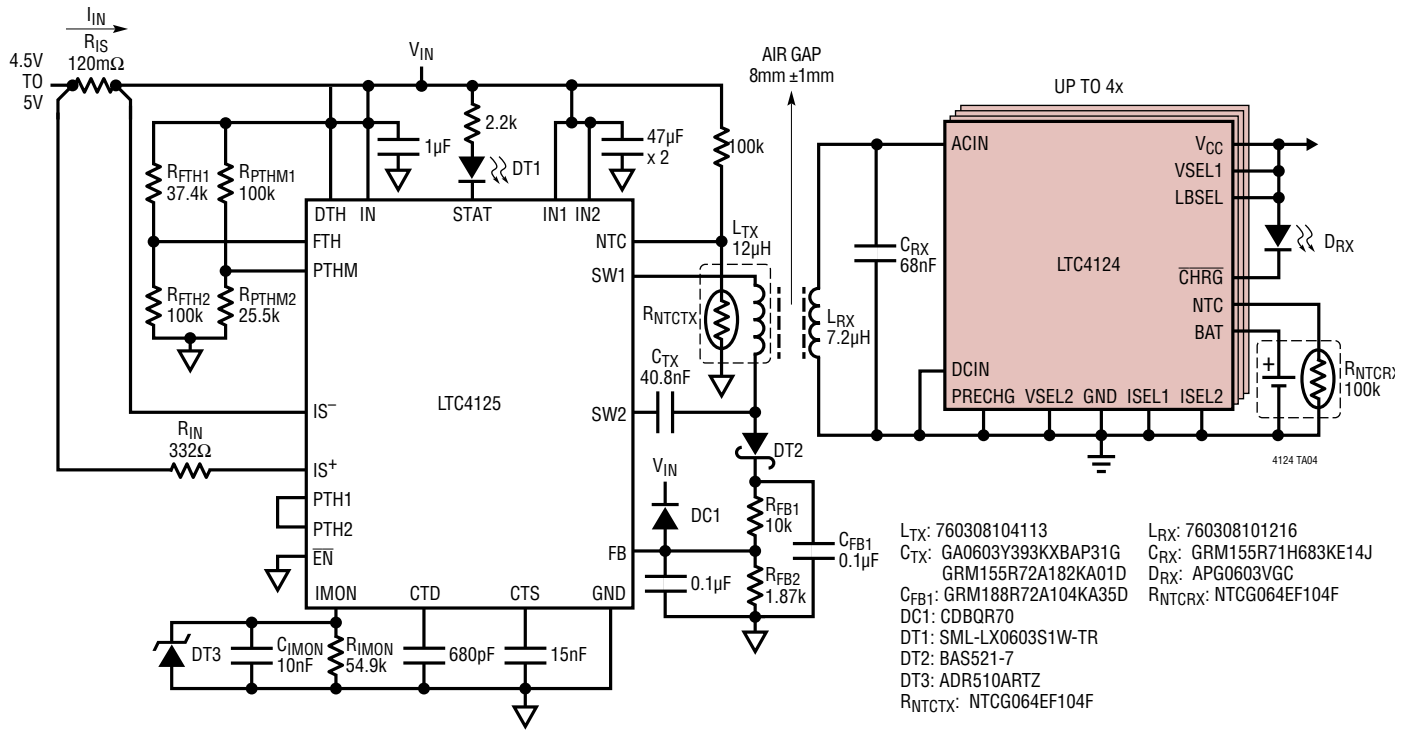

## RELATED PARTS

PART NUMBER	DESCRIPTION	COMMENTS
<a href="#">LTC4123</a>	Low Power Wireless Charger for Hearing Aids	Wireless NiMH Charger, Temperature Compensated Charge Voltage, 1.5V at 25°C, 25mA Charge Current, 2mm × 2mm DFN-6 Package.
<a href="#">LTC4126</a>	Low Power Li-Ion Wireless Charger with Step Down Regulator for Hearing Aids	Wireless Single Cell Li-Ion Charger, Internal Temperature Qualified Charging, 4.2V at 25°C, 7.5mA Charge Current, Integrated High Efficiency 1.2V Regulator, 2mm × 2mm LQFN Package.
<a href="#">LTC4070</a>	Li-Ion/Polymer Shunt Battery Charger System	Low Operating Current (450nA), 1% Float Voltage Accuracy Over Full Temperature and Shunt Current Range, 50mA Maximum Internal Shunt Current (500mA with External PFET), Pin-Selectable Float Voltages: 4.0V, 4.1V, 4.2V. Ultralow Power Pulsed NTC Float Conditioning for Li-Ion/Polymer Protection, 8-Lead 2mm × 3mm DFN and MSOP.
<a href="#">LTC4071</a>	Li-Ion/Polymer Shunt Battery Charger System with Low Battery Disconnect	Integrated Pack Protection, <10nA Low Battery Disconnect Protects Battery from Over-Discharge. Low Operating Current (550nA), 1% Float Voltage Accuracy Over Full Temperature and Shunt Current Range, 50mA Maximum Internal Shunt Current, Pin-Selectable Float Voltages: 4.0V, 4.1V, 4.2V. Ultralow Power Pulsed NTC Float Conditioning for Li-Ion/Polymer Protection, 8-Lead 2mm × 3mm DFN and MSOP.
<a href="#">LTC6990</a>	TimerBlox: Voltage-Controlled Silicon Oscillator	Fixed-Frequency or Voltage-Controlled Operation.
<a href="#">LTC4125</a>	5W AutoResonant Wireless Power Transmitter	Monolithic AutoResonant™ Full Bridge Driver. Transmit Power Automatically Adjusts to Receiver Load, Foreign Object Detection, Wide Operating Switching Frequency Range: 50kHz-250kHz, Input Voltage Range 3V to 5.5V, 20-Lead 4mm × 5mm QFN Package.
<a href="#">LTC4120</a>	Wireless Power Receiver and 400mA Buck Battery Charger	Wireless 1 to 2 Cell Li-Ion Charger, 400mA Charge Current, Dynamic Harmonization Control, Wide Input Range: 12.5V – 40V, 3mm × 3mm QFN-16 Package.

Компания «Life Electronics» занимается поставками электронных компонентов импортного и отечественного производства от производителей и со складов крупных дистрибьюторов Европы, Америки и Азии.

С конца 2013 года компания активно расширяет линейку поставок компонентов по направлению коаксиальный кабель, кварцевые генераторы и конденсаторы (керамические, пленочные, электролитические), за счёт заключения дистрибьюторских договоров

Мы предлагаем:

- Конкурентоспособные цены и скидки постоянным клиентам.
- Специальные условия для постоянных клиентов.
- Подбор аналогов.
- Поставку компонентов в любых объемах, удовлетворяющих вашим потребностям.
- Приемлемые сроки поставки, возможна ускоренная поставка.
- Доставку товара в любую точку России и стран СНГ.
- Комплексную поставку.
- Работу по проектам и поставку образцов.
- Формирование склада под заказчика.
- Сертификаты соответствия на поставляемую продукцию (по желанию клиента).
- Тестирование поставляемой продукции.
- Поставку компонентов, требующих военную и космическую приемку.
- Входной контроль качества.
- Наличие сертификата ISO.

В составе нашей компании организован Конструкторский отдел, призванный помогать разработчикам, и инженерам.

Конструкторский отдел помогает осуществить:

- Регистрацию проекта у производителя компонентов.
- Техническую поддержку проекта.
- Защиту от снятия компонента с производства.
- Оценку стоимости проекта по компонентам.
- Изготовление тестовой платы монтаж и пусконаладочные работы.



Тел: +7 (812) 336 43 04 (многоканальный)

Email: [org@lifeelectronics.ru](mailto:org@lifeelectronics.ru)