

### General Description

The TQQ0303 is an exceptionally high performance BAW filter for the LTE Band 3 downlink. This filter is housed in a compact 3 x 3 mm package for base station applications.

Low insertion loss, coupled with high attenuation makes this filter an ideal choice for downlink RF filtering needs.

The TQQ0303 is part of Qorvo's extensive portfolio of RF BAW and SAW filters.



6 Pin 3 x 3 mm leadless SMT Package

### Functional Block Diagram

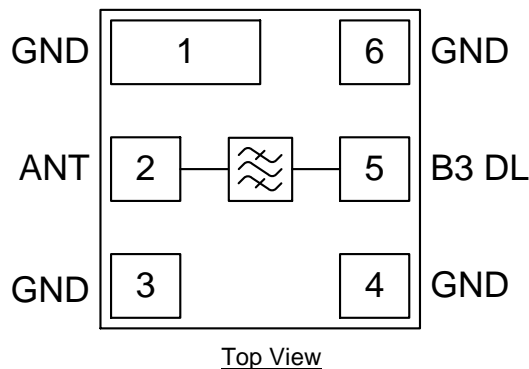

### Product Features

- Usable Bandwidth 75 MHz at 1842.5 MHz
- Internally Match for 50 Ohm Operation
- Low Insertion Loss
- Small Size: 3.00 x 3.00 x 1.07 mm
- Surface Mount Device
- RoHS compliant, Pb-free
- High power handling of 1W

### Applications

- Base Station Infrastructure
- Repeaters
- General Purpose Wireless

### Pin Configuration

Pin No.	Label
1, 3, 4, 6	Ground
2	ANT
5	B3 DL

### Ordering Information

Part No.	Description
TQQ0303	2,500 pieces on a 7" reel (standard)
TQQ0303-PCB	Evaluation Board

## Absolute Maximum Ratings

Parameter	Rating
Storage Temperature	-40 to +85 °C
Operation Temperature	-40 to +85 °C
RF Input Power <sup>(1)</sup> (Pin 2, 5)	+30 dBm

Notes:

1. Input Power: CW, at +55 °C for 10,000 hours.

## Recommended Operating Conditions

Parameter	Min	Typ	Max	Units
T <sub>CASE</sub>	0	-	+70	°C

Electrical specifications are measured at specified test conditions.

## Electrical Specifications – B3 DL

Operating Temperature Range: +0 to +70°C.

Parameter	Conditions	Min	Typ	Max	Units
Center Frequency [fo]		-	1842.5	-	MHz
Insertion Loss	1805 MHz – 1880 MHz	-	2.58	3.8	dB
Amplitude Variation <sup>(1)</sup>	1805 MHz – 1880 MHz	-	1.6	-	dB
Lower Band Edge <sup>(2)</sup>	Insertion Loss = -15 dB	1795	1796.3	-	MHz
Upper Band Edge <sup>(2)</sup>	Insertion Loss = -15 dB		1894.6	1900	MHz
Absolute Attenuation	500 MHz – 1200 MHz	20	23	-	dB
	1300 MHz – 1770 MHz	22	25	-	dB
	1785 MHz – 1795 MHz	15 <sup>(2)</sup>	23.7	-	dB
	1900 MHz – 1925 MHz	15 <sup>(2)</sup>	30	-	dB
Input Return Loss	1805 MHz – 1880 MHz	8	9.1	-	dB
Output Return Loss	1805 MHz – 1880 MHz	8	10.9	-	dB
Load/Source Impedance		-	50	-	Ω

Notes:

1. Describe the total variation over the defined frequency range
2. At +25°C only.

**TQQ0303-PCB Evaluation Board**

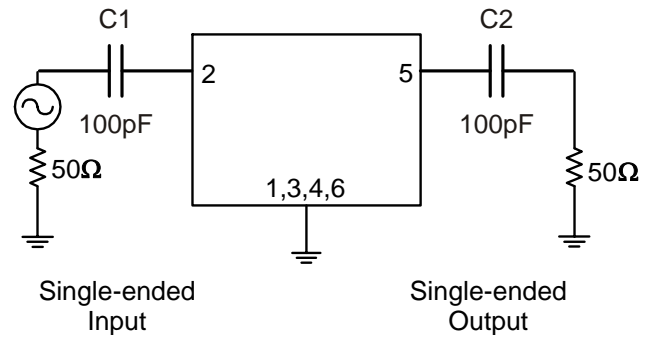
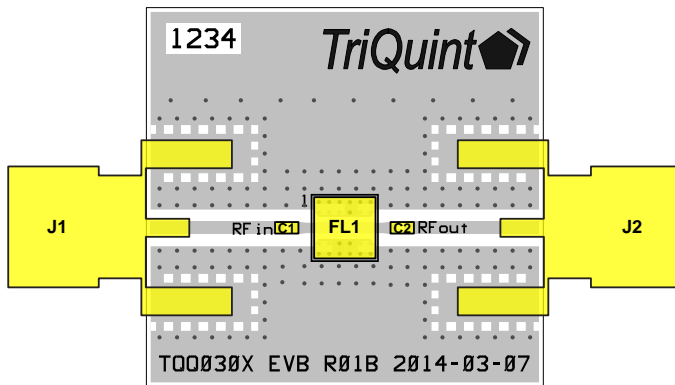

**Bill of Material – TQQ0303-PCB**

Reference Des.	Value	Description	Manuf.	Part Number
n/a	n/a	Printed Circuit Board	Qorvo	1124609
U1	n/a	Band 3 Downlink BAW Filter	Qorvo	TQQ0303
C1, C2	100 pF	Cap., Chip, 0402, 5%, 50V, NPO/COG	various	various
J1, J2	n/a	SMA Edge Connector	Johnson	142-0701-851

**Evaluation Board PCB Information**

Top, middle & bottom layers: 1 oz copper

Substrates: FR4 dielectric, 0.0139", 0.028", 0.0139" thick

Performance Plots – Band 3 DL

Test conditions unless otherwise noted: Temp= +25°C

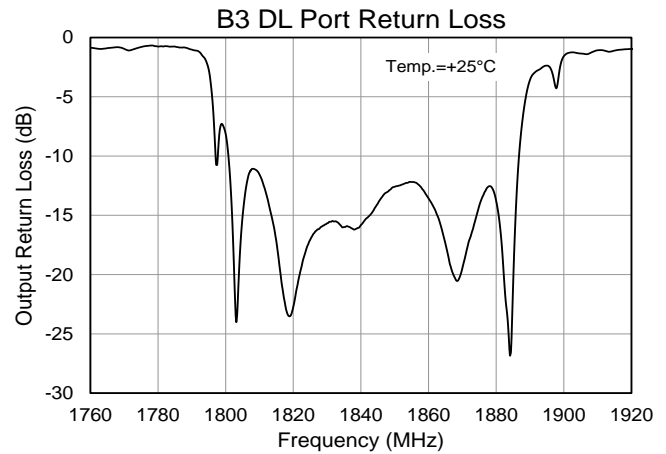
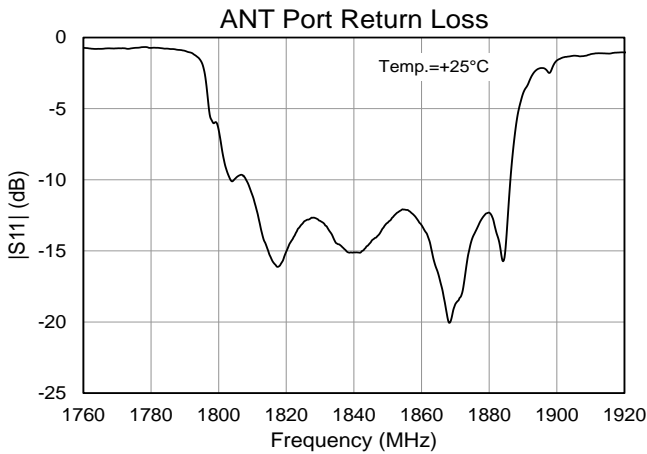
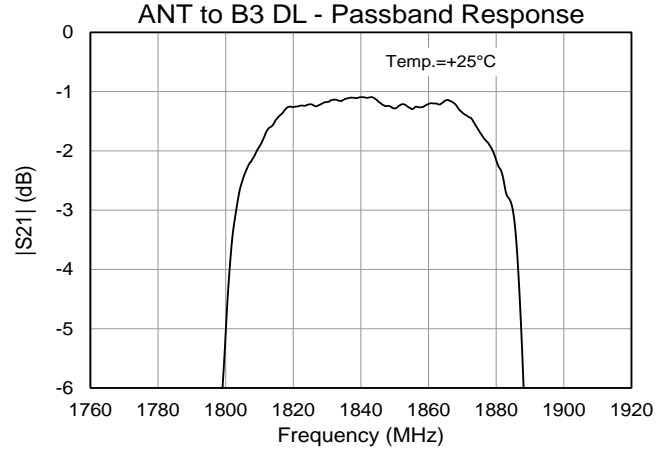
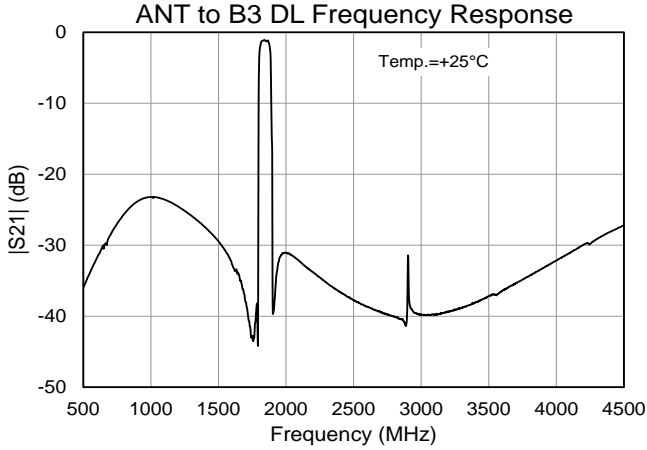

## Package Marking and Dimensions

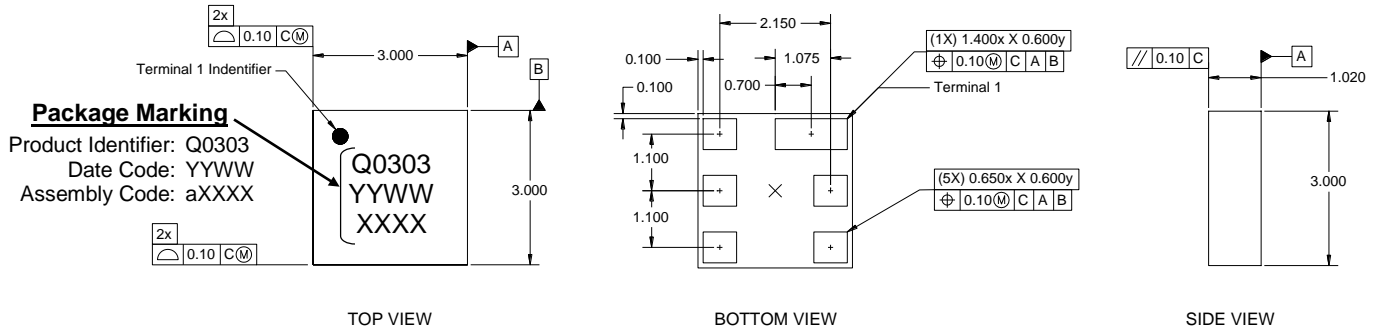

**Notes:**

1. All dimensions are in millimeters. Angles are in degrees.
2. Dimension and tolerance formats conform to ASME Y14.4M-1994.
3. The terminal #1 identifier and terminal numbering conform to JESD 95-1 SPP-012.

## PCB Mounting Pattern

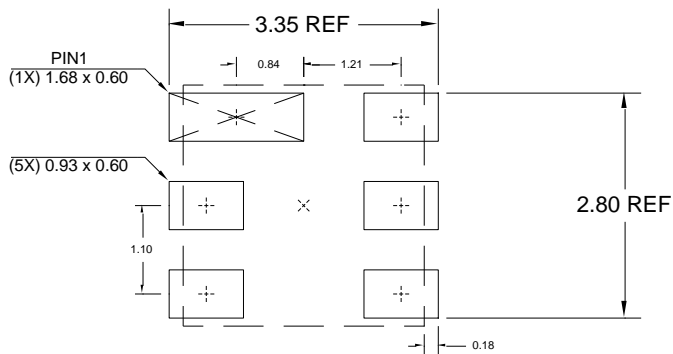

Top view recommended land pattern metallization.

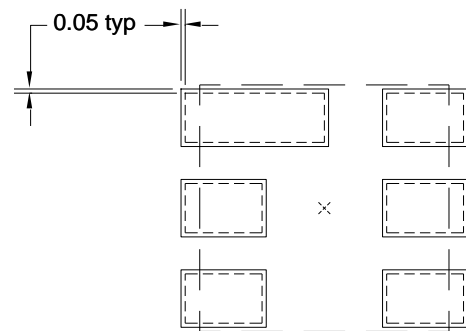

Top view recommended land pattern stencil aperture.

**Notes:**

1. All dimensions are in millimeters. Angles are in degrees.
2. Use 1 oz. copper minimum for top and bottom layer metal.

**Tape and Reel Information – Carrier and Cover Tape Dimensions**

Tape and reel specifications for this part are also available on the Qorvo website.  
Standard T/R size = 2500 pieces on a 7” reel.

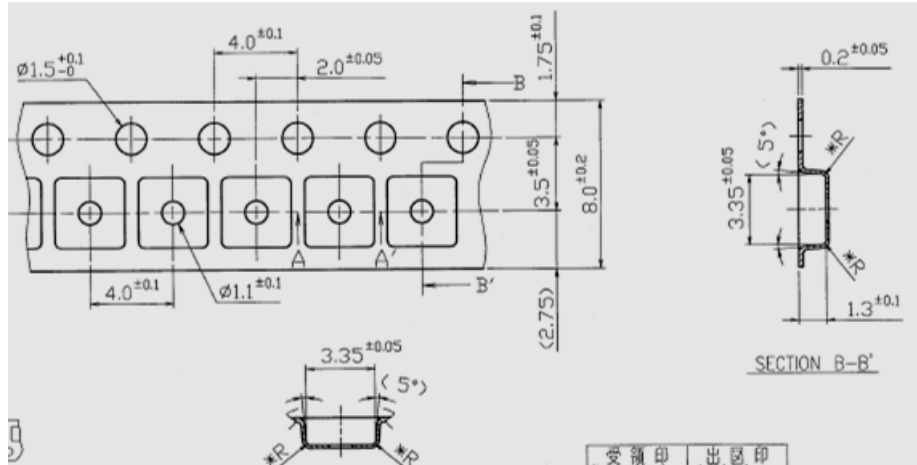

Feature	Measure	Symbol	Size (in)	Size (mm)
Cavity	Length	A0	0.132	3.35
	Width	B0	0.132	3.35
	Depth	K0	0.051	1.30
	Pitch	P1	0.157	4.00
Centerline Distance	Cavity to Perforation - Length Direction	P2	0.079	2.00
	Cavity to Perforation - Width Direction	F	0.138	3.50
Cover Tape	Width	C	0.213	5.40
Carrier Tape	Width	W	0.315	8.00

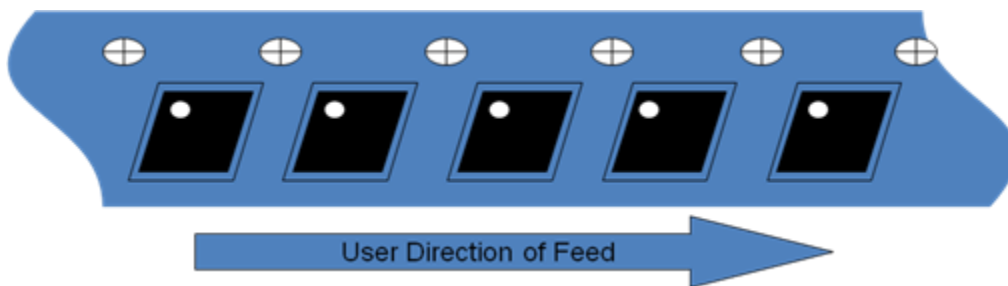

**Tape and Reel Information – Reel Dimensions**

Tape and reel specifications for this part are also available on the Qorvo website.  
 Standard T/R size = 2500 pieces on a 7” reel.

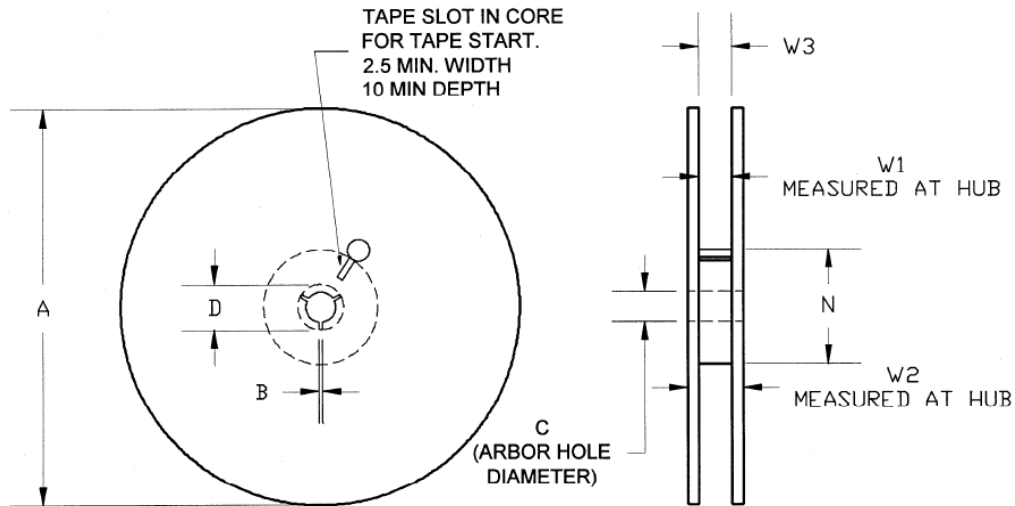

Feature	Measure	Symbol	Size (in)	Size (mm)
Flange	Diameter	A	6.969	177.0
	Thickness	W2	0.559	14.2
	Space Between Flange	W1	0.346	8.8
Hub	Outer Diameter	N	2.283	58.0
	Arbor Hole Diameter	C	0.512	13.0
	Key Slit Width	B	0.079	2.0
	Key Slit Diameter	D	0.787	20.0

## Handling Precautions

Parameter	Rating	Standard
ESD – Human Body Model (HBM)	Class 1B	ANSI / ESD / JEDEC JS-001
ESD – Charged Device Model (CDM)	Class B	ANSI / ESD / JEDEC JS-002
MSL – Moisture Sensitivity Level	Level 3	IPC/JEDEC J-STD-020



Caution!  
ESD-Sensitive Device

## Solderability

Compatible with lead-free (260°C max. reflow temp.) soldering process.  
Solder profiles available upon request.

Contact plating: Ni Au

## RoHS Compliance

This part is compliant with 2011/65/EU RoHS directive (Restrictions on the Use of Certain Hazardous Substances in Electrical and Electronic Equipment) as amended by Directive 2015/863/EU.

This product also has the following attributes:

- Lead Free
- Halogen Free (Chlorine, Bromine)
- Antimony Free
- TBBP-A (C<sub>15</sub>H<sub>12</sub>Br<sub>4</sub>O<sub>2</sub>) Free
- PFOS Free
- SVHC Free



## Contact Information

For the latest specifications, additional product information, worldwide sales and distribution locations:

**Web:** [www.qorvo.com](http://www.qorvo.com)

**Tel:** 1-844-890-8163

**Email:** [customer.support@qorvo.com](mailto:customer.support@qorvo.com)

For technical questions and application information: **Email:** [appsupport@qorvo.com](mailto:appsupport@qorvo.com)

## Important Notice

The information contained herein is believed to be reliable; however, Qorvo makes no warranties regarding the information contained herein and assumes no responsibility or liability whatsoever for the use of the information contained herein. All information contained herein is subject to change without notice. Customers should obtain and verify the latest relevant information before placing orders for Qorvo products. The information contained herein or any use of such information does not grant, explicitly or implicitly, to any party any patent rights, licenses, or any other intellectual property rights, whether with regard to such information itself or anything described by such information. **THIS INFORMATION DOES NOT CONSTITUTE A WARRANTY WITH RESPECT TO THE PRODUCTS DESCRIBED HEREIN, AND QORVO HEREBY DISCLAIMS ANY AND ALL WARRANTIES WITH RESPECT TO SUCH PRODUCTS WHETHER EXPRESS OR IMPLIED BY LAW, COURSE OF DEALING, COURSE OF PERFORMANCE, USAGE OF TRADE OR OTHERWISE, INCLUDING THE IMPLIED WARRANTIES OF MERCHANTABILITY AND FITNESS FOR A PARTICULAR PURPOSE.**

Without limiting the generality of the foregoing, Qorvo products are not warranted or authorized for use as critical components in medical, life-saving, or life-sustaining applications, or other applications where a failure would reasonably be expected to cause severe personal injury or death.

Copyright 2017 © Qorvo, Inc. | Qorvo is a registered trademark of Qorvo, Inc.



Компания «Life Electronics» занимается поставками электронных компонентов импортного и отечественного производства от производителей и со складов крупных дистрибьюторов Европы, Америки и Азии.

С конца 2013 года компания активно расширяет линейку поставок компонентов по направлению коаксиальный кабель, кварцевые генераторы и конденсаторы (керамические, пленочные, электролитические), за счёт заключения дистрибьюторских договоров

Мы предлагаем:

- Конкурентоспособные цены и скидки постоянным клиентам.
- Специальные условия для постоянных клиентов.
- Подбор аналогов.
- Поставку компонентов в любых объемах, удовлетворяющих вашим потребностям.
- Приемлемые сроки поставки, возможна ускоренная поставка.
- Доставку товара в любую точку России и стран СНГ.
- Комплексную поставку.
- Работу по проектам и поставку образцов.
- Формирование склада под заказчика.
- Сертификаты соответствия на поставляемую продукцию (по желанию клиента).
- Тестирование поставляемой продукции.
- Поставку компонентов, требующих военную и космическую приемку.
- Входной контроль качества.
- Наличие сертификата ISO.

В составе нашей компании организован Конструкторский отдел, призванный помогать разработчикам, и инженерам.

Конструкторский отдел помогает осуществить:

- Регистрацию проекта у производителя компонентов.
- Техническую поддержку проекта.
- Защиту от снятия компонента с производства.
- Оценку стоимости проекта по компонентам.
- Изготовление тестовой платы монтаж и пусконаладочные работы.



Тел: +7 (812) 336 43 04 (многоканальный)

Email: [org@lifeelectronics.ru](mailto:org@lifeelectronics.ru)