

## Simple 90V, 25mA, Temperature Compensated, Constant Current, LED Driver IC

### Features

- ▶ 5.0V to 90V operating range ( $V_{A-B}$ )
- ▶ 25mA  $\pm 10\%$  at 5-90V
- ▶ 0.01% / °C typical temperature coefficient
- ▶ No external components (two terminal device)
- ▶ Can be paralleled for higher current

### Applications

- ▶ LED channel lighting
- ▶ Industrial lamp indicators
- ▶ Accent lighting

### General Description

The Supertex CL25 is a high voltage, temperature compensated, constant current source. The device is trimmed to provide a constant current of 25mA  $\pm 10\%$  at an input voltage of 5-90V. No external components are required. The device can be used as a two terminal constant current source or constant current sink.

A typical application for the CL25 is to drive LEDs with a constant current of 25mA. They can also be used in parallel to provide higher currents such as 50mA, 75mA or 100mA. The device is available in TO-92 and TO-243AA (SOT-89) packaging.

### Typical Application Circuit

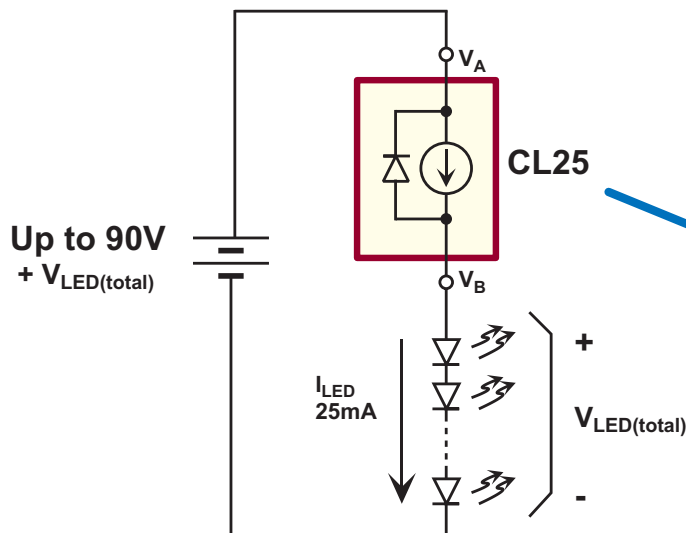

### Functional Circuit Diagram

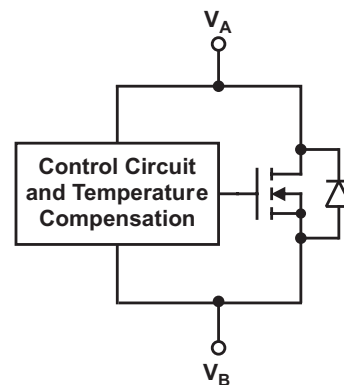

### Ordering Information

Device	Package Options	
	TO-92	TO-243AA (SOT-89)
CL25	CL25N3-G	CL25N8-G



-G indicates package is RoHS compliant ('Green')

### Thermal Characteristics

Package	Power Dissipation @ $T_A = 25^\circ\text{C}$	$\theta_{JC}$ °C/W	$\theta_{JA}$ °C/W
TO-92	0.6W	125	170
TO-243AA (SOT-89)	1.3W*	15	78*

\* Mounted on FR4 board; 25mm x 25mm x 1.57mm

### Absolute Maximum Ratings

Parameter	Value
Operating voltage, $V_{A-B}$	100V
Operating junction temperature, $T_J$	-40°C to +125°C
Storage temperature, $T_S$	-55°C to +150°C

Absolute Maximum Ratings are those values beyond which damage to the device may occur. Functional operation under these conditions is not implied. Continuous operation of the device at the absolute rating level may affect device reliability. All voltages are referenced to device ground.

### Electrical Characteristics

( $T_J=25^\circ\text{C}$  unless otherwise specified)

Symbol	Parameter	Min	Typ	Max	Units	Conditions
$V_{A-B}$	Operating voltage	5	-	90	V	---
$I_{A-B}$	Current regulation	22.5	25	27.5	mA	$V_{A-B} = 5V - 90V$
$\Delta I_{A-B}/\Delta T$	$I_{A-B}$ temperature coefficient	-	0.01	-	%/°C	$V_{A-B} = 45V, T_J = -40^\circ\text{C}$ to $+100^\circ\text{C}$
$T_J$	Operating junction temperature	-40	-	125	°C	---
$R_{A-B}$	Dynamic resistance	-	300k	-	$\Omega$	---

### Pin Configuration

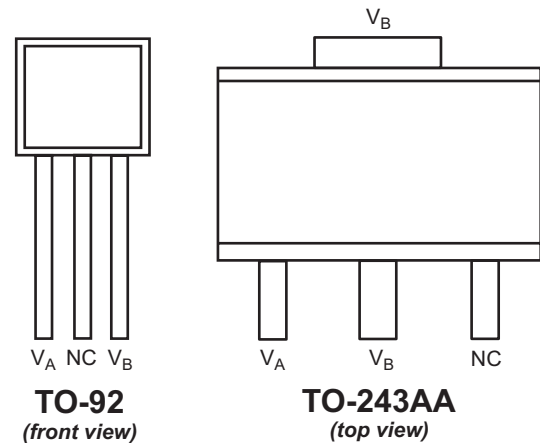

NC = No Connect

### Functional Circuit Diagram

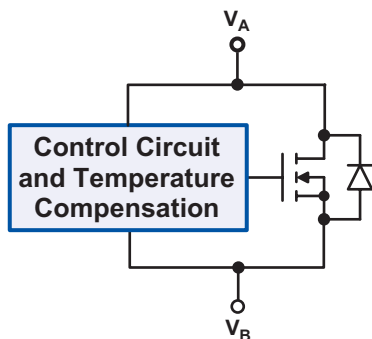

### Equivalent Block Diagram

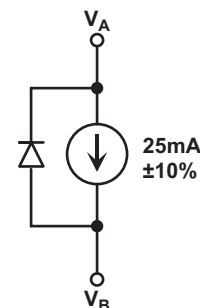

### Temperature Characteristics

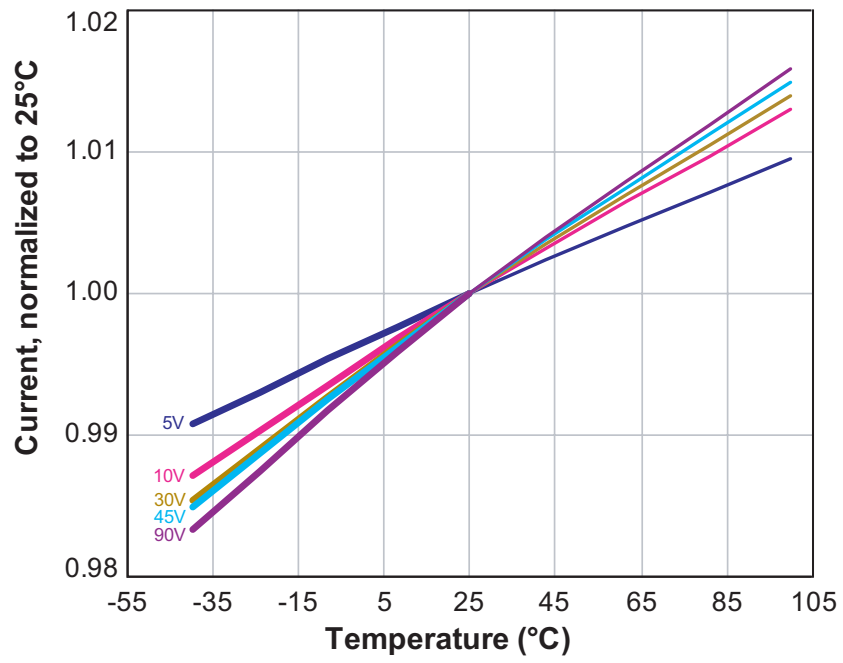

### Output Current vs Voltage

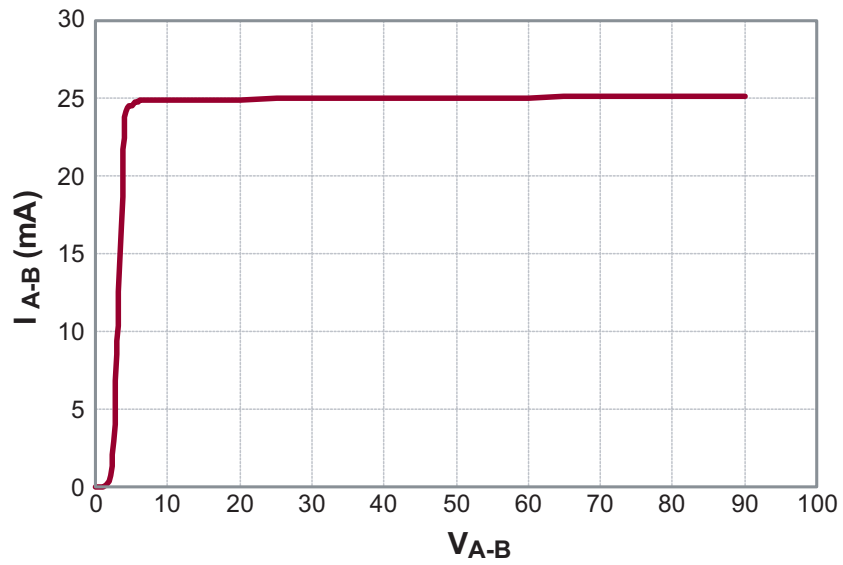

### CL25 for Multiple LED Strings

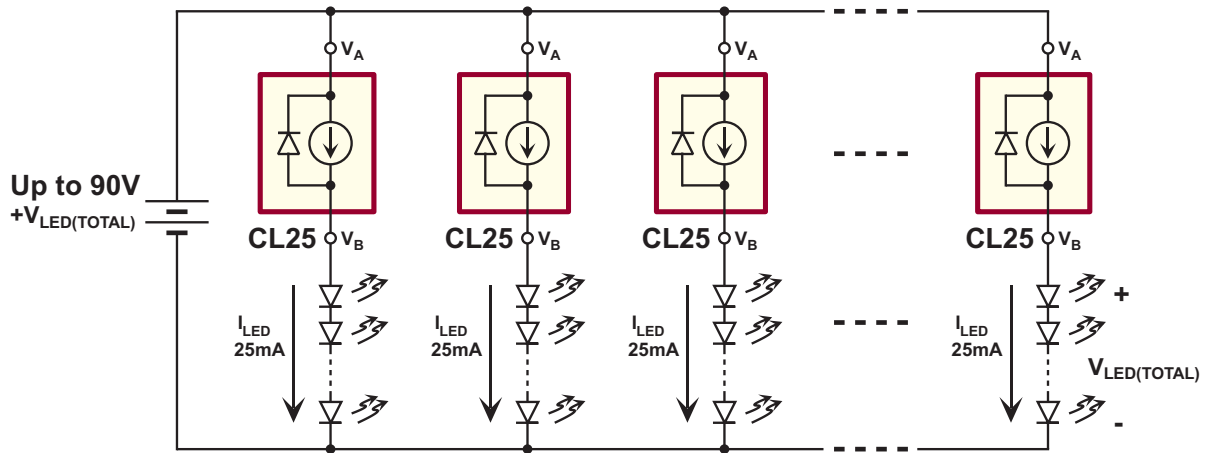

### CL25 for Higher Current

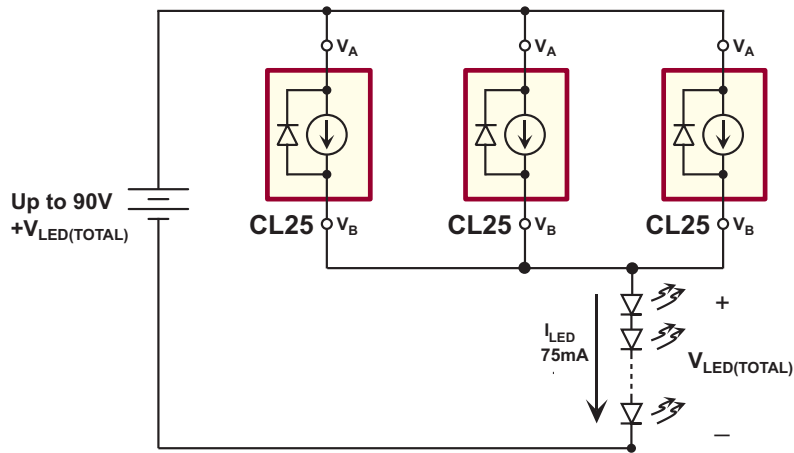

### 3-Lead TO-92 Package Outline (N3)

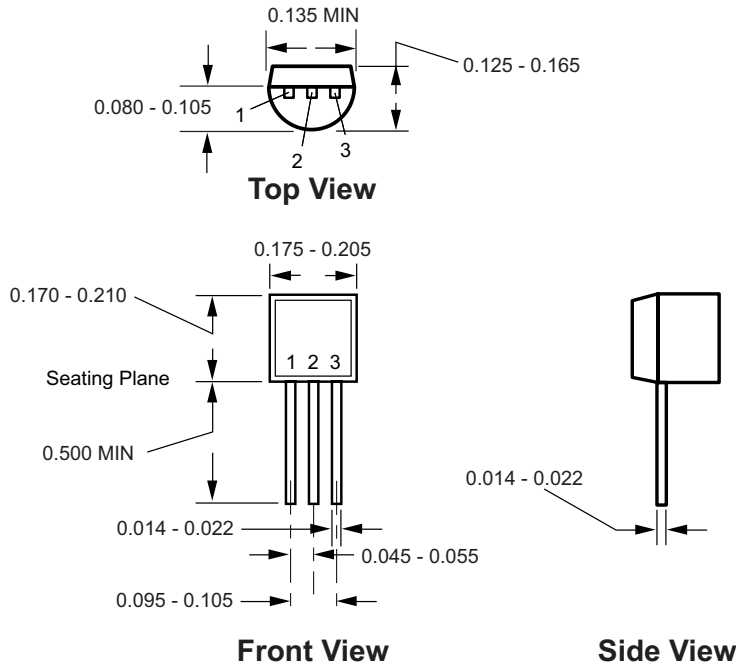

**Notes:**  
All dimensions are in millimeters; all angles in degrees.

### 3-Lead TO-243AA (SOT-89) Package Outline (N8)

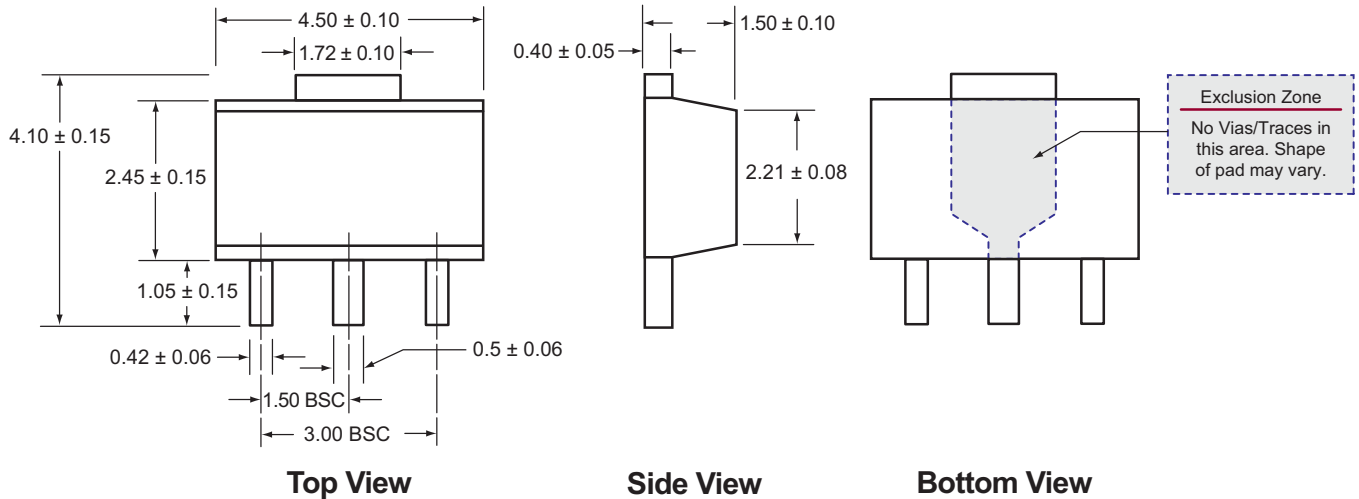

**Notes:**  
All dimensions are in millimeters; all angles in degrees.

(The package drawings in this data sheet may not reflect the most current specifications. For the latest package outline information go to <http://www.supertex.com/packaging.html>.)

**Supertex inc.** does not recommend the use of its products in life support applications, and will not knowingly sell its products for use in such applications, unless it receives an adequate "product liability indemnification insurance agreement". **Supertex** does not assume responsibility for use of devices described and limits its liability to the replacement of the devices determined defective due to workmanship. No responsibility is assumed for possible omissions or inaccuracies. Circuitry and specifications are subject to change without notice. For the latest product specifications, refer to the **Supertex** website: <http://www.supertex.com>.

©2006 **Supertex inc.** All rights reserved. Unauthorized use or reproduction is prohibited.

**Supertex inc.**

1235 Bordeaux Drive, Sunnyvale, CA 94089  
TEL: (408) 222-8888 / FAX: (408) 222-4895

[www.supertex.com](http://www.supertex.com)

Компания «Life Electronics» занимается поставками электронных компонентов импортного и отечественного производства от производителей и со складов крупных дистрибьюторов Европы, Америки и Азии.

С конца 2013 года компания активно расширяет линейку поставок компонентов по направлению коаксиальный кабель, кварцевые генераторы и конденсаторы (керамические, пленочные, электролитические), за счёт заключения дистрибьюторских договоров

Мы предлагаем:

- Конкурентоспособные цены и скидки постоянным клиентам.
- Специальные условия для постоянных клиентов.
- Подбор аналогов.
- Поставку компонентов в любых объемах, удовлетворяющих вашим потребностям.
- Приемлемые сроки поставки, возможна ускоренная поставка.
- Доставку товара в любую точку России и стран СНГ.
- Комплексную поставку.
- Работу по проектам и поставку образцов.
- Формирование склада под заказчика.
- Сертификаты соответствия на поставляемую продукцию (по желанию клиента).
- Тестирование поставляемой продукции.
- Поставку компонентов, требующих военную и космическую приемку.
- Входной контроль качества.
- Наличие сертификата ISO.

В составе нашей компании организован Конструкторский отдел, призванный помогать разработчикам, и инженерам.

Конструкторский отдел помогает осуществить:

- Регистрацию проекта у производителя компонентов.
- Техническую поддержку проекта.
- Защиту от снятия компонента с производства.
- Оценку стоимости проекта по компонентам.
- Изготовление тестовой платы монтаж и пусконаладочные работы.



Тел: +7 (812) 336 43 04 (многоканальный)

Email: [org@lifeelectronics.ru](mailto:org@lifeelectronics.ru)