

Features

- GPS multichip module:
 - STA2058 TESEO Baseband
 - STA5620 RF Front-end
- Complete embedded memory system:
 - Flash 256 KB + 16 Kbytes
 - RAM 64 Kbytes.
- 66-MHz ARM7TDMI 32 bit processor
- High performance GPS engine (HPGPS)
- SBAS (WAAS and EGNOS) supported
- Sensitivity (-146 dBm acquisition, -159 dBm tracking)
- Time to first fix (1 s reacquisition, 2.5 s hot start, 34 s warm start, 39 s cold start)
- Accuracy (2 m autonomous)
- Extensive GPS receiver interfaces: 32 GPIOs, 4 UARTs, 2 SPIs, 2 I2Cs, 1 CAN 2.0, 1 USB 1.1, 1 HDLC and 4 channels ADC
- Compatible with L1 signal (C/A code)
- ST proprietary technology
 - CMOS Flash embedded technology for STA2058
 - BiCMOS Sige technology for STA5620
- LFBGA104 lead-free package
- -40 °C to 85 °C operating temperature range

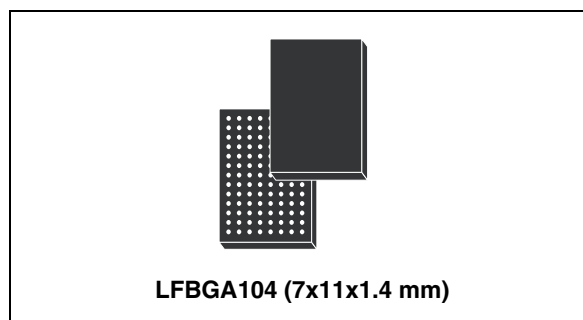

- Evaluation kits:
 - STA8058 module reference designs (17x19 mm and 25x25 mm)
 - Evaluation board hosting STA8058 module

Description

STA8058 TESEO MCM is a fully embedded GPS engine integrating STA2058 TESEO baseband and STA5620 RF front-end. The embedded Flash memory enables the equipment manufacturer to load the entire GPS software (including tracking, acquisition, navigation and data output) after customising its interfaces to his needs.

A standard GPS library is available from ST. By combining the ARM7TDMI microcontroller core with on-chip Flash/RAM, 16-channel GPS correlator DSP, RF Front-end and an extensive range of interfaces on single package solution, the STA8058 provides a highly-flexible and cost-effective solution for GPS applications.

Table 1. Device summary

Order code	Package	Packing	Automotive grade	CAN
STA8058	LFBGA104 (7 x 11 x 1.4 mm)	Tray	No	No
STA8058TR	LFBGA104 (7 x 11 x 1.4 mm)	Tape and reel	No	No
STA8058A	LFBGA104 (7 x 11 x 1.4 mm)	Tray	Yes	Yes
STA8058ATR	LFBGA104 (7 x 11 x 1.4 mm)	Tape and reel	Yes	Yes

Contents

1	Features summary	3
2	Pin description	5
2.1	Logic symbol	5
2.2	System block diagram	6
2.3	LFBGA104 ball out	9
2.4	Power supply pins	9
3	Electrical characteristics	11
4	Package information	12
5	Revision history	13

1 Features summary

- ARM7TDMI 16/32 bit RISC CPU based host microcontroller running at a frequency up to 66 MHz.
- Complete Embedded Memory System:
 - Flash 256 Kbytes + 16 Kbytes (100 KB erasing/programming cycles)
 - RAM 64 Kbytes.
- 16 channel High performance GPS correlation DSP.
- ST proprietary technology:
 - CMOS Flash embedded technology for baseband
 - BiCMOS Sige for radio front-end
- SBAS (WAAS and EGNOS) supported.
- -40 °C to 85 °C operating temperature range.
- 104-pin LFBGA104 package.
- Power supply:
 - 3.0 V to 3.6 V operating supply range for input/output periphery
 - 3.0 V to 3.6 V operating supply range for A/D converter reference
 - 1.8 V operating supply range for core supply provided by internal voltage regulator with external stabilization capacitor or by external supply voltage
 - 2.4 V to 3 V operating supply range for RF front-end section
- Reset and clock control unit able to provide low power modes (WAIT, SLOW, STOP, Standby) and to generate the internal clock from the external reference through integrated PLL.
- 32 programmable general purpose I/O, each pin programmable independently as digital input or digital output; 30 are multiplexed with peripheral functions; 16 can generate an interrupt on input level/transition.
- Real time clock module with 32 kHz low power oscillator and separate power supply to continue running during stand-by mode.
- 16-bit Watchdog timer with 8 bits prescaler for system reliability and integrity.
- One CAN module compliant with the CAN specification V2.0 part B (active) and bit rate can be programmed up to 1 MBaud.
- Four 16-bit programmable timers with 7 bit prescaler, up to two input capture/output compare, one pulse counter function, one PWM channel with selectable frequency each.
- 4 channels 12-bit sigma-delta analog to digital converter, single channel or multi channel conversion modes, single-shot or continuous conversion modes, sample rate 1 kHz, conversion range 0-2.5V .
- Three serial communication interfaces (UART) allow full duplex, asynchronous, communications with external devices, independently programmable TX and RX baud rates up to 625K baud.
- One UART adapted to suit smart card interface needs, for asynchronous SC as defined by ISO 7816-3. It includes SC clock generation.
- Two serial peripheral interfaces (SPI) allow full duplex, synchronous communications with external devices, master or slave operation, max baud rate of 5.5Mb/s. One SPI may be used as multimedia card interface.

- Two I²C interfaces provide multi-master and slave functions, support normal and fast I²C mode (400 KHz), 7/10 bit addressing modes. One I²C Interface is multiplexed with one SPI, so either 2 x SPI + 1 x I²C or 1 x SPI + 2 x I²C may be used at a time.
- Enhanced interrupt controller supports 32 interrupt vectors, independently maskable, with interrupt vector table for faster response and 16 priority levels, software programmable for each source. Up to 2 maskable interrupts may be mapped on FIQ.
- Wake-up unit allows exiting from powerdown modes by detection of an event on two external pins (one is active high and other is active low) or on internal Real Time Clock alarm.
- USB unit V1.1 compliant, software configurable endpoint setting, USB suspend/resume support
- High level data link controller (HDLC) unit supports full duplex operating mode, NRZ, NRZI, FM0 and MANCHESTER modes, and internal 8-bit Baud Rate Generator.
- RF front-end features:
 - LOW IF (4 MHz) architecture
 - Compatible with GPS L1 signal
 - VGA gain internally regulated
 - On chip programmable PLL
 - SPI interface

2 Pin description

2.1 Logic symbol

Figure 1. STA8058 TESEO MCM symbol

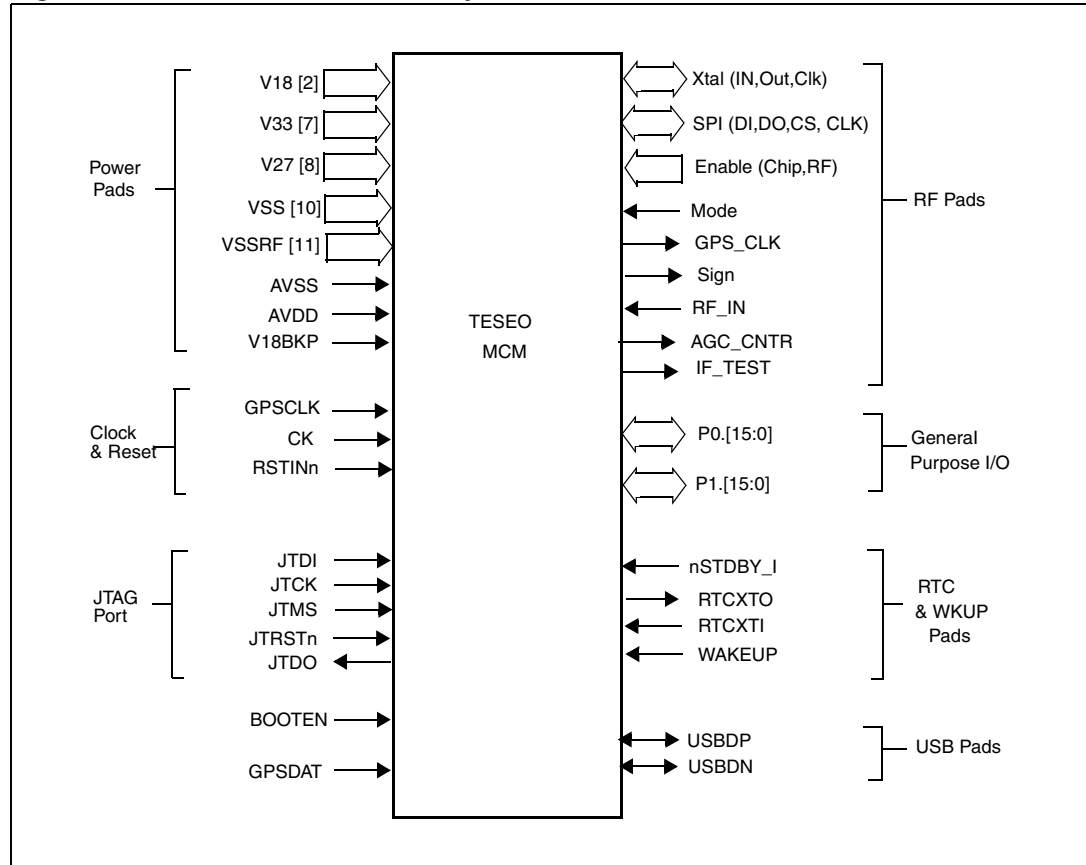

2.2 System block diagram

Figure 2. STA8058 TESEO baseband block diagram

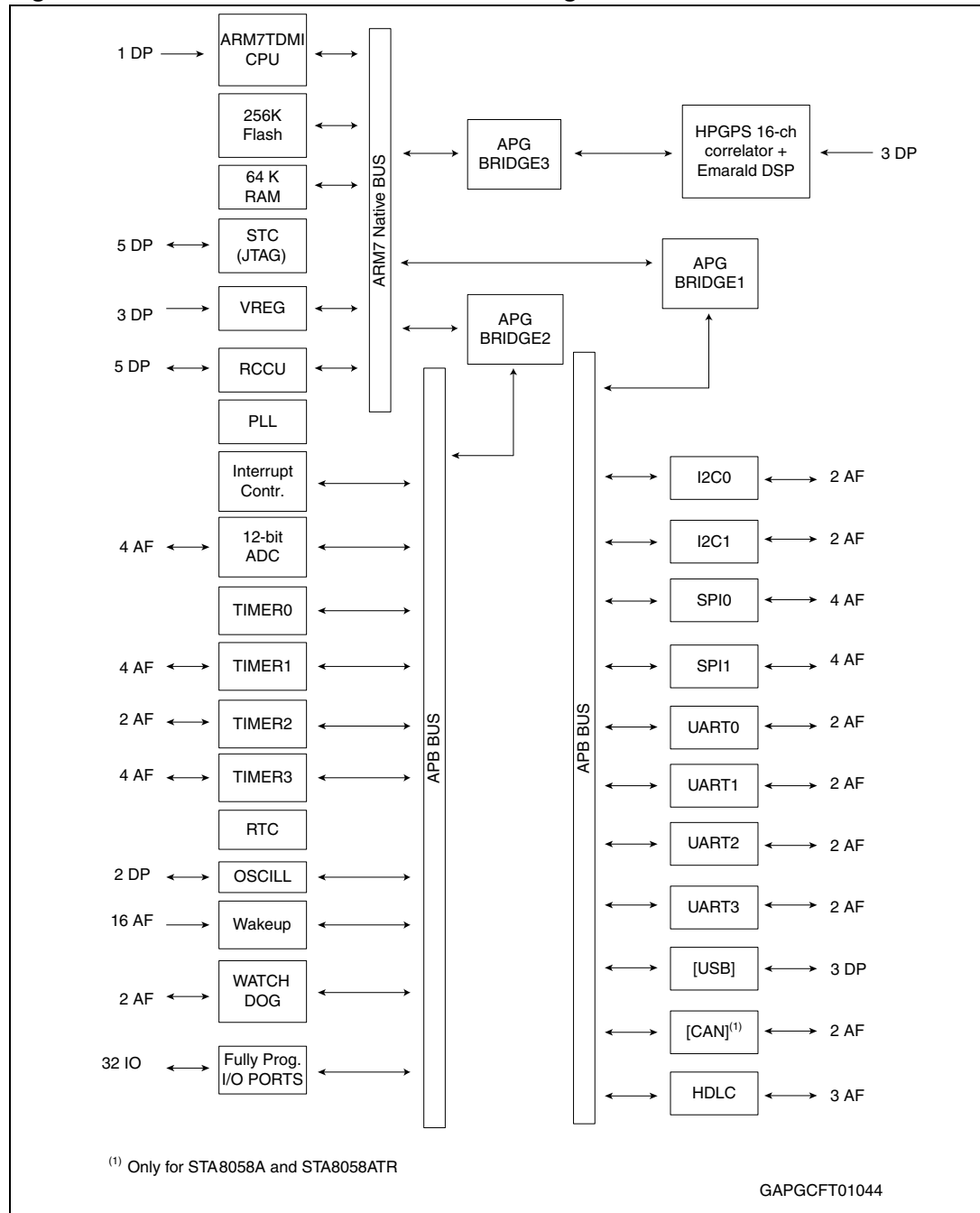

Figure 3. STA5620 RF front-end

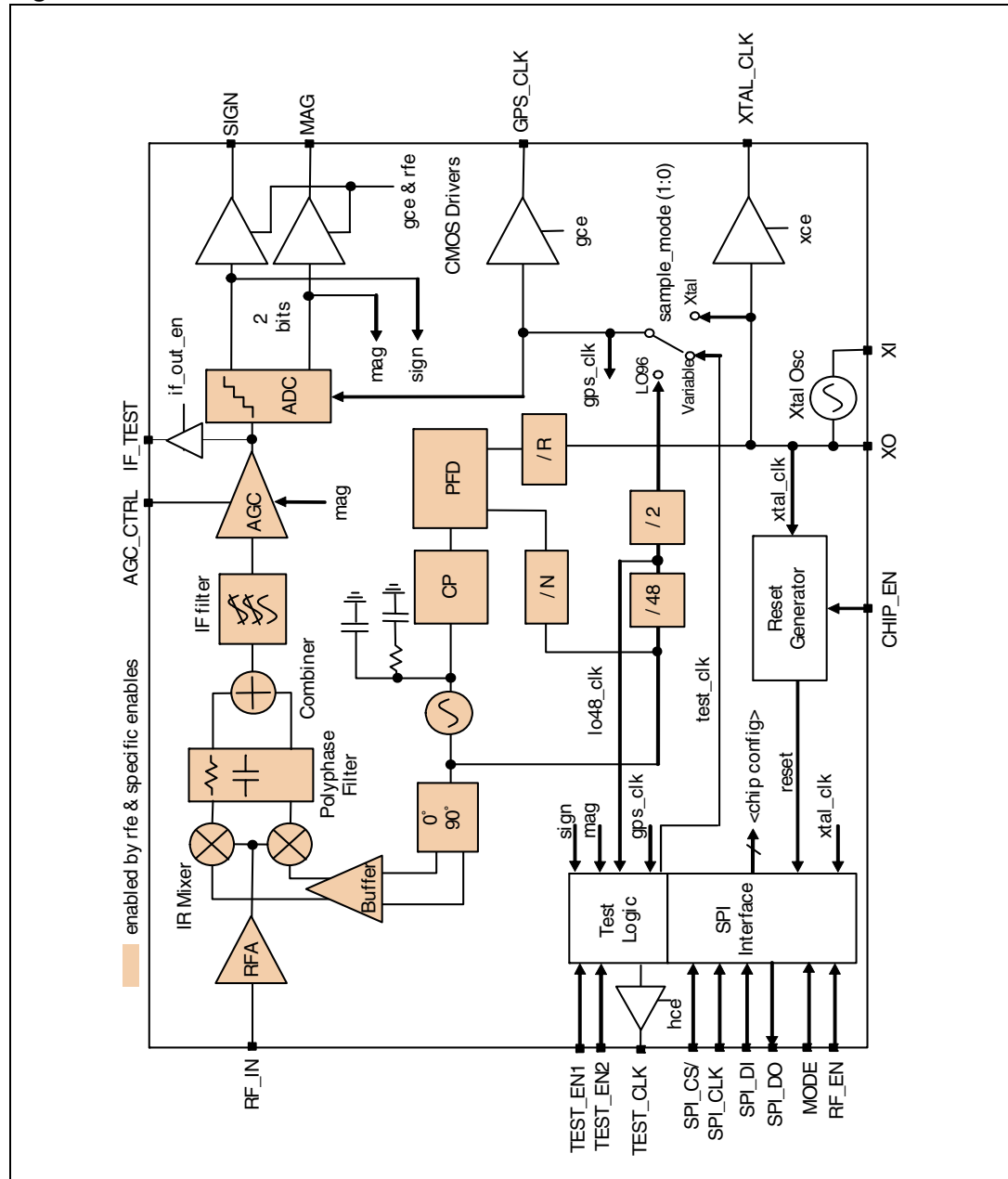
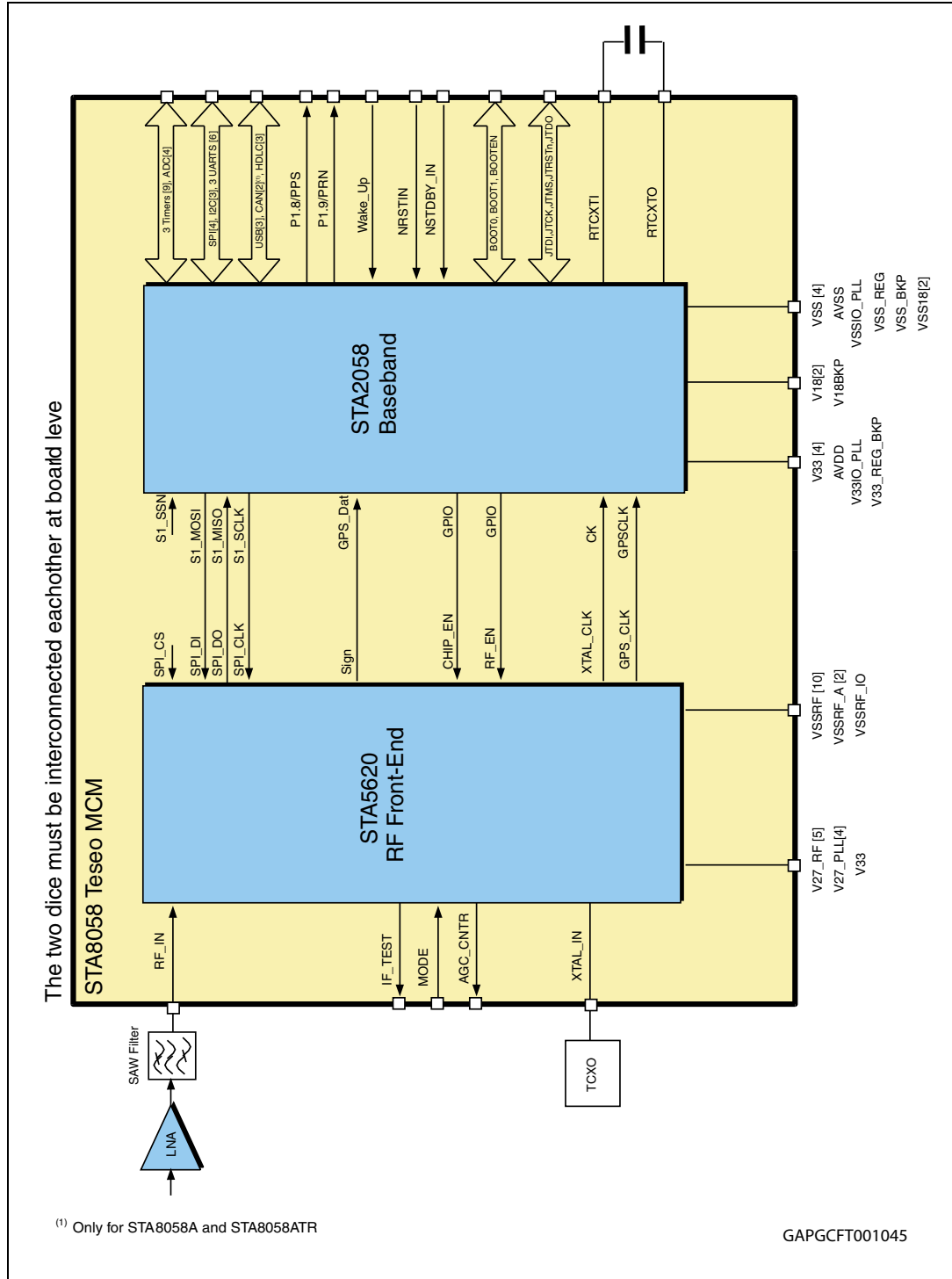

Figure 4. STA8058 TESEO MCM block diagram



2.3 LFBGA104 ball out

Table 2. Ball out for LFBGA104 package

	1	2	3	4	5	6	7	8	9	10	11	12	13
A	VSS	AVSS	AVDD	V18BKP	RTCXTO	RTCXTI	V33REG_BKP	GPSDAT	nJTRST	RF_EN	XTAL_OUT	XTAL_IN	VSSRF
B	P1.2/ T3_OCMPA/ AIN.2	VSS18	V18	VSSBKP	NSTDBY_IN	V33	VSSREG	GPSCLK	GPS_CLK	CHIP_EN	V27PLL	V27PLL	V27PLL
C	P1.1/ T3_ICAPA/ AIN.1	P1.0/ T3_OCMPB/ AIN.0	P1.4/ T1_ICAPA	P1.5/ T1_ICAPB	NRSTIN	PO.15/ WAKEUP	CK	P0.5/ S1_MOSI	SPI_DI	XTAL_CLK	VSSRF	V27PLL	V27RF
D	V33IO_PLL	P1.3/ T3_ICAPB/ AIN.3	P1.7/ T1_OCMPA	VSS	VSS	JTCK	JTDO	P0.6/S1_SCLK	SPI_CLK	MODE	VSSRF	VSSRF	VSSRF_A
E	VSSIO_PLL	P1.8/PPS	P1.9/ PRN.11	P1.6/ T1_OCMPB	VSS18	P0.13/ U2_RX/ T2_OCMPA	JTMS	JTDI	SPI_CS	IF_TEST	VSSRF	VSSRF	RF_IN
F	P1.11/ CANRX ⁽¹⁾	USBDP	P1.10/ USBCLK	P0.3/ SO_SSN/ I1.SDA	V18	P0.14/ U2_TX/ T2.ICAPA	V33	P0.4/ S1_MISO	SPI_DO	AGC_CNTR	VSSRF	VSSRF	VSSRF_A
G	P1.12/ CANTX ⁽¹⁾	USBDN	P0.1/ SO_MOSI/ U3.RX	P0.0/ SO_MISO/ U3.TX	P0.7/S1_SSN	P0.9/ UO_TX/ BOOT.0	P0.11/ U1_TX/ BOOT.1	BOOTEN	SIGN	V27RF	V27RF	V27RF	VSSRF
H	VSS	P1.13/ HCLK/ IO.SCL	P1.14/ HRXD/ IO.SDA	P1.15/ HTXD	P0.2/ SO_SCLK/ I1.SCL	PO.12/ SCCLK	PO.8/ UO_RX/ U0.TX	P0.10/ U1_RX/ U1.TX	V33	VSSRF:IO	V33	V27RF	VSSRF

1. Only for STA8058A and STA8058ATR.

2.4 Power supply pins

Table 3. Power supply pins

Symbol	I/O	Function	LFBGA104
V ₃₃	-	Digital supply voltage for I/O circuitry (3.3 Volt)	B6, F7, G10, H9, H11
V _{SS}	-	Digital ground for I/O circuitry	A1, D4, D5, H1
V _{33IO-PLL}	-	Digital supply voltage for I/O circuitry and for PLL reference (3.3V)	D1
V _{SSIO-PLL}	-	Digital ground for I/O circuitry and for PLL reference	E1
V _{33REG_BKP}	-	Digital supply voltage for backup block I/O circuitry and for Ballast I/O (3.3V)	A7
V _{SSREG}	-	Digital ground for Ballast I/O	B7
V ₁₈	-	Digital supply voltage for core circuitry (1.8 Volt): When using the internal voltage regulator, this pin shall not be driven by an external voltage supply, but a capacitance of at least 10µF (Tantalum, low series resistance) + 33nF (ceramic) shall be connected between these pins and V _{SS18} to guarantee on-chip voltage stability.	B3, F5
V _{SS18}	-	Digital ground for core circuitry	B2, E5
V _{18BKP}	-	Digital supply voltage for backup block (RTC, oscillator, Wake-up controller - 1.8 Volt): when using the internal voltage regulator, this pin shall not be driven by an external voltage supply, but a capacitance of at least 1µF shall be connected between this pin and V _{SSBKP} to guarantee on-chip voltage stability.	A4

Table 3. Power supply pins (continued)

Symbol	I/O	Function	LFBGA104
V _{SSBKP}	-	Digital ground for backup logic	B4
AV _{DD}	-	Analog supply voltage for the A/D converter	A3
AV _{SS}	-	Analog supply ground for the A/D converter	A2
V _{27RF}	-	Analog supply voltage for RF chain (2.7V)	C13, G10, G11, G12, H12
V _{27PLL}	-	Analog supply voltage for PLL embedded into RF part (2.7V)	B11, B12, B13, C12
V _{SSRF}	-	Analog supply ground for RF core	A13, C11, D11, D13, E11, E12, F11, F12, G13, H13
V _{SSRF_A}	-	Analog supply ground for RF amplifier	D13, F13
V _{SSRF_IO}	-	Analog supply ground for RF IO circuitry	H10

Note: V₃₃ and V_{33IO-PLL} are all internally connected. Same for V_{SS} and V_{SSIO-PLL}.
All V_{SS}, V_{SS18}, V_{SSBKP}, AV_{SS}, V_{SSRF}, V_{SSRF_A} and V_{SSRF_IO} pins must be tied together to the common ground plane, taking care of noise filtering, especially on AV_{SS}, V_{SSRF}, V_{SSRF_A} and V_{SSRF_IO}

3 Electrical characteristics

See STA2058 (Teseo Baseband) and STA5620 (RF Front-end) datasheet for related data.

4 Package information

In order to meet environmental requirements, ST offers these devices in different grades of ECOPACK® packages, depending on their level of environmental compliance. ECOPACK® specifications, grade definitions and product status are available at: www.st.com.

ECOPACK® is an ST trademark.

Figure 5. LFBGA104 (11x7x1.4mm) mechanical data and package dimensions

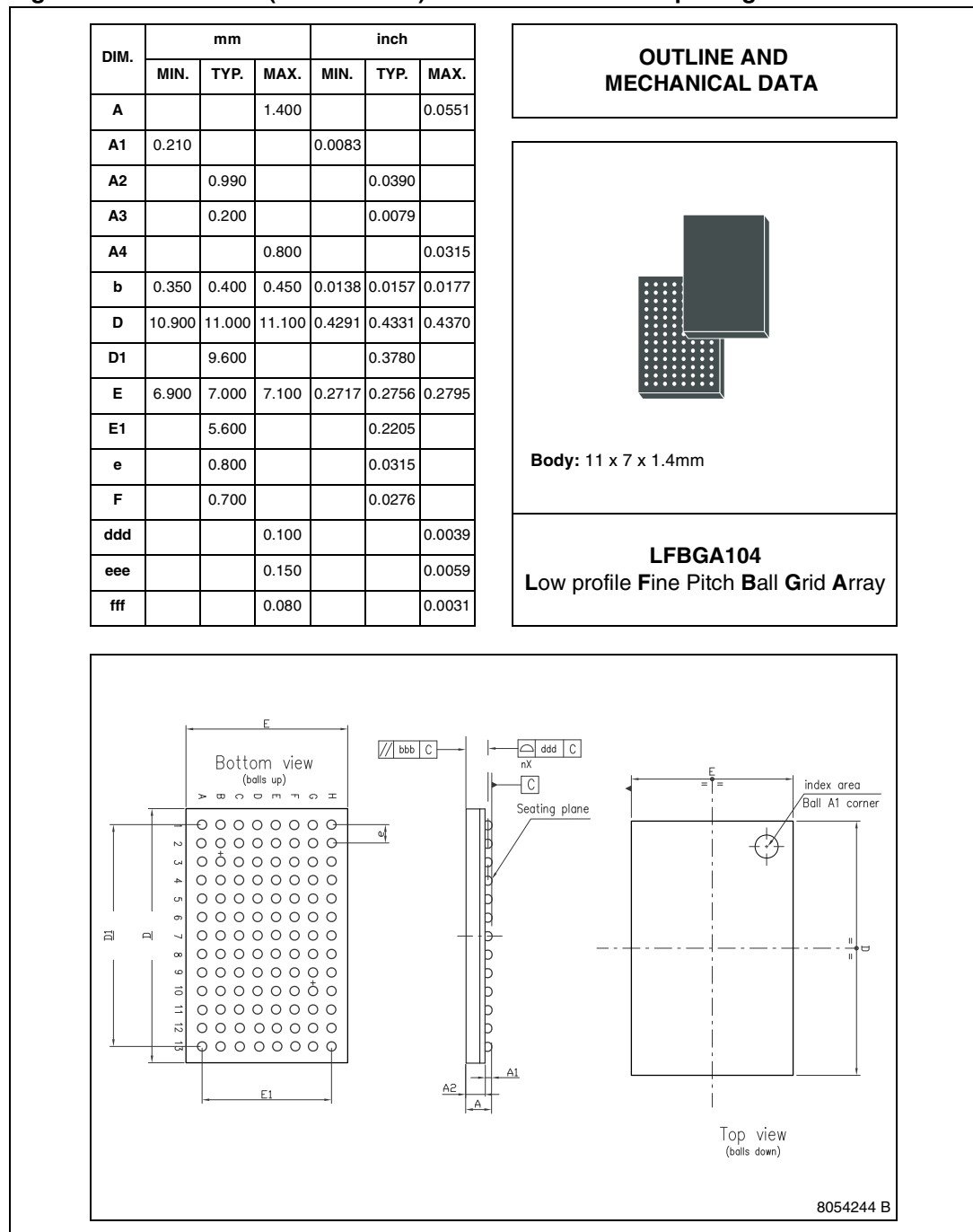

5 Revision history

Table 4. Document revision history

Date	Revision	Changes
25-Oct-2007	1	Initial release.
19-Mar-2009	2	Updated Table 1: Device summary on page 1 . Updated ECOPACK description in Section 4: Package information on page 12 .
23-Oct-2012	3	Updated Table 1: Device summary Updated Figure 2: STA8058 TESEO baseband block diagram and Figure 4: STA8058 TESEO MCM block diagram Updated Table 2: Ball out for LFBGA104 package
17-Sep-2013	4	Updated Disclaimer

Please Read Carefully:

Information in this document is provided solely in connection with ST products. STMicroelectronics NV and its subsidiaries ("ST") reserve the right to make changes, corrections, modifications or improvements, to this document, and the products and services described herein at any time, without notice.

All ST products are sold pursuant to ST's terms and conditions of sale.

Purchasers are solely responsible for the choice, selection and use of the ST products and services described herein, and ST assumes no liability whatsoever relating to the choice, selection or use of the ST products and services described herein.

No license, express or implied, by estoppel or otherwise, to any intellectual property rights is granted under this document. If any part of this document refers to any third party products or services it shall not be deemed a license grant by ST for the use of such third party products or services, or any intellectual property contained therein or considered as a warranty covering the use in any manner whatsoever of such third party products or services or any intellectual property contained therein.

UNLESS OTHERWISE SET FORTH IN ST'S TERMS AND CONDITIONS OF SALE ST DISCLAIMS ANY EXPRESS OR IMPLIED WARRANTY WITH RESPECT TO THE USE AND/OR SALE OF ST PRODUCTS INCLUDING WITHOUT LIMITATION IMPLIED WARRANTIES OF MERCHANTABILITY, FITNESS FOR A PARTICULAR PURPOSE (AND THEIR EQUIVALENTS UNDER THE LAWS OF ANY JURISDICTION), OR INFRINGEMENT OF ANY PATENT, COPYRIGHT OR OTHER INTELLECTUAL PROPERTY RIGHT.

ST PRODUCTS ARE NOT DESIGNED OR AUTHORIZED FOR USE IN: (A) SAFETY CRITICAL APPLICATIONS SUCH AS LIFE SUPPORTING, ACTIVE IMPLANTED DEVICES OR SYSTEMS WITH PRODUCT FUNCTIONAL SAFETY REQUIREMENTS; (B) AERONAUTIC APPLICATIONS; (C) AUTOMOTIVE APPLICATIONS OR ENVIRONMENTS, AND/OR (D) AEROSPACE APPLICATIONS OR ENVIRONMENTS. WHERE ST PRODUCTS ARE NOT DESIGNED FOR SUCH USE, THE PURCHASER SHALL USE PRODUCTS AT PURCHASER'S SOLE RISK, EVEN IF ST HAS BEEN INFORMED IN WRITING OF SUCH USAGE, UNLESS A PRODUCT IS EXPRESSLY DESIGNATED BY ST AS BEING INTENDED FOR "AUTOMOTIVE, AUTOMOTIVE SAFETY OR MEDICAL" INDUSTRY DOMAINS ACCORDING TO ST PRODUCT DESIGN SPECIFICATIONS. PRODUCTS FORMALLY ESCC, QML OR JAN QUALIFIED ARE DEEMED SUITABLE FOR USE IN AEROSPACE BY THE CORRESPONDING GOVERNMENTAL AGENCY.

Resale of ST products with provisions different from the statements and/or technical features set forth in this document shall immediately void any warranty granted by ST for the ST product or service described herein and shall not create or extend in any manner whatsoever, any liability of ST.

ST and the ST logo are trademarks or registered trademarks of ST in various countries.

Information in this document supersedes and replaces all information previously supplied.

The ST logo is a registered trademark of STMicroelectronics. All other names are the property of their respective owners.

© 2013 STMicroelectronics - All rights reserved

STMicroelectronics group of companies

Australia - Belgium - Brazil - Canada - China - Czech Republic - Finland - France - Germany - Hong Kong - India - Israel - Italy - Japan - Malaysia - Malta - Morocco - Philippines - Singapore - Spain - Sweden - Switzerland - United Kingdom - United States of America

www.st.com

Компания «Life Electronics» занимается поставками электронных компонентов импортного и отечественного производства от производителей и со складов крупных дистрибьюторов Европы, Америки и Азии.

С конца 2013 года компания активно расширяет линейку поставок компонентов по направлению коаксиальный кабель, кварцевые генераторы и конденсаторы (керамические, пленочные, электролитические), за счёт заключения дистрибьюторских договоров

Мы предлагаем:

- Конкурентоспособные цены и скидки постоянным клиентам.
- Специальные условия для постоянных клиентов.
- Подбор аналогов.
- Поставку компонентов в любых объемах, удовлетворяющих вашим потребностям.
- Приемлемые сроки поставки, возможна ускоренная поставка.
- Доставку товара в любую точку России и стран СНГ.
- Комплексную поставку.
- Работу по проектам и поставку образцов.
- Формирование склада под заказчика.
- Сертификаты соответствия на поставляемую продукцию (по желанию клиента).
- Тестирование поставляемой продукции.
- Поставку компонентов, требующих военную и космическую приемку.
- Входной контроль качества.
- Наличие сертификата ISO.

В составе нашей компании организован Конструкторский отдел, призванный помогать разработчикам, и инженерам.

Конструкторский отдел помогает осуществить:

- Регистрацию проекта у производителя компонентов.
- Техническую поддержку проекта.
- Защиту от снятия компонента с производства.
- Оценку стоимости проекта по компонентам.
- Изготовление тестовой платы монтаж и пусконаладочные работы.



Тел: +7 (812) 336 43 04 (многоканальный)

Email: org@lifeelectronics.ru