

Blocks and Holders



<i>Fuse Blocks</i>	111
<i>Class H/K5 and R Fuse Blocks</i>	112-116
<i>Class J Fuse Blocks</i>	117-119
<i>Class T Fuse Blocks</i>	120-123
<i>Class G Fuse Blocks</i>	124
<i>Class CC/CD and Midget Fuse Blocks</i>	125-126
<i>Class CC and Midget Fuse Block Accessories</i>	127
<i>Fuse Block, Holders and Accessories</i>	128-133
<i>Semiconductor Fuse Blocks</i>	134-136
<i>POWR-BLOKS™ Distribution/Splicer Blocks</i>	137-144
<i>In-Line Watertight Fuseholders</i>	145-150

Fuse Blocks

General Information



Fuse Block Selection

The following guidelines should help simplify the selection of proper fuse blocks:

1. Determine the system voltage

Since fuses are selected on the basis of system voltage, fuse blocks are selected to match the voltage rating of the fuse.

2. Determine the design short-circuit current

Available and/or design short-circuit current is an important consideration when determining the class of fuse and fuse blocks to use. If available short-circuit current cannot be determined, or if it will vary with equipment location, select fuses with a 200,000 ampere interrupting rating (A.I.R.) and mating fuse blocks with a withstand rating of 200,000 amperes for maximum safety.

Class H fuse blocks will accept Class H or K5 fuses (which have an interrupting rating of up to 50,000 amperes) and Class R fuses (which have a 200,000 A.I.R.). To prevent the possibility of inserting a fuse with the incorrect interrupting rating, the use of Class R fuse blocks is recommended for use with Class R fuses. Use Class H fuse blocks with Class H or K5 fuses. These fuse blocks are dimensionally the same, but the Class R fuse blocks incorporate a rejection feature which allows only Class R fuses to be inserted.

3. Determine the type and ampere rating of the fuse to be used

In addition to voltage and interrupting rating as discussed above, the fuse ampere rating, opening characteristics (fast acting or time-delay) and size are other important considerations in fuse selection. Once the fuse type is selected, the mating fuse block can be chosen. Fuse blocks are available in 30, 60, 100, 200, 400 and 600 amp ratings, and may be used with a fuse rated at the corresponding ampere rating or below. For example, a fuse block rated at 30 amperes may be used with a fuse rated from 0 to 30 amperes.

4. Determine if NEC, CSA, UL, or other requirements are applicable

If fuse blocks will be installed in equipment to be submitted for agency approval, the requirements should be obtained from the approving agency in advance of fuse and fuse block selection.

5. Select the type of wire termination

A choice of three types of wire termination is available:

- a) Screw* — for use with spade lugs or ring terminals.
- b) Screw with Pressure Plate* — for use with solid or stranded wire without terminal. Recommended where vibration will be a factor.
- c) Box Lug — the most durable. For use with all types of solid wire and Class B and Class C stranded wire. Not for use with welding cable or other rope-stranded conductors.

* 1/4" Quick Connect terminals rated for up to 20A are available on the Midget and Class CC fuse blocks.

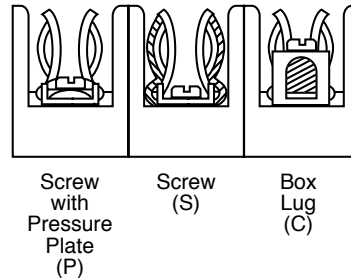

6. Decide on the number of poles in each block

The number of poles for each set of fuses is determined by the characteristics of the circuit. The option to gang individual fuse blocks into long strips will be determined by the available space and by the type of wire being used.

7. Determine if fuse clips need to be reinforced

Fuse clips may have a tendency to lose some of their tension over a period of time. This may be prevented by specifying reinforced fuse clips. Reinforced clips are standard on certain fuse blocks (see individual product pages).

Ordering Information

The Littelfuse fuse block part number consists of 6 or 7 components, as shown below and in the individual fuse block data tables.

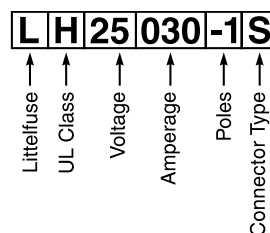

For all Class R, H, J, T and 15, 20 & 60A Class G Fuse Blocks

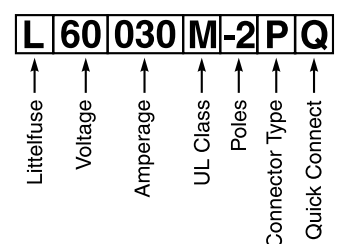

For all Class CC, Midget and 30A Class G Fuse Blocks

Class H/K5 and R Fuse Blocks

250 and 600 Volt



Class H and Class R fuse blocks are dimensionally the same, but Class R blocks incorporate a rejection feature, which only allows Class R fuses to be inserted.

Features/Benefits

- Class H and Class R fuse blocks feature clip designs to maximize electrical contact and minimize heat rise.
- Reinforcing clips are standard on all Class H fuse blocks rated 100 amp and higher. *Note: For reinforcing clips on Class H blocks rated 30-60 amp, add "R" suffix to connector type.*
- Reinforcing clips are standard on all Class R fuse blocks

Specifications

Voltage Rating: 250 Volts; 600 Volts
Ampere Ratings: 0 – 600 amperes
Approvals: UL Listed (File No. E14721)
 CSA Certified (File No. LR73091)

Recommended Fuses

Class H Blocks			Class R Blocks		
250V	600V		250V	600V	
NLN	NLS		FLNR/FLNR_ID	FLSR/FLSR_ID	
RLN	RLS		KLNR	KLSR	
			LLNRK	LLSRK/LLSRK_ID	
			TLN	IDSR	

Note: For optional fuse block covers, refer to POWR-Covers section of this catalog.

Class H 250V

Amp Rating	No. of Poles	Catalog Number	Connector Type (Add Suffix Shown)			Maximum Wire Size
			Screw	Pressure Plate	Box Lug	
30	1	LH25030-1	S (R)	P (R)	C (R)	S & P = #10 CU
	2	LH25030-2	S (R)	P (R)	C (R)	C = #6 CU-AL
	3	LH25030-3	S (R)	P (R)	C (R)	
60	1	LH25060-1	S (R)		C (R)	S = #10 CU
	2	LH25060-2	S (R)		C (R)	C = #2 CU-AL
	3	LH25060-3	S (R)		C (R)	
100	1	LH25100-1			C	
	2	LH25100-2			C	#2/0 CU-AL
	3	LH25100-3			C	
200	1	LH25200-1			C	
	3	LH25200-3			C	250 MCM CU-AL
	1	LH25400-1			CR	
400	3	LH25400-3			CR	(2) 350 MCM CU-AL
	1	LH25600-1			C	
	3	LH25600-3			C	(2) 500 MCM CU-AL

Note: Reinforcing springs standard on all Class H fuseblocks 100 amperes and above.

Class R 250V

Amp Rating	No. of Poles	Catalog Number	Connector Type (Add Suffix Shown)			Maximum Wire Size
			Screw	Pressure Plate	Box Lug	
30	1	LR25030-1	SR	PR	CR	S & P = #10 CU
	2	LR25030-2	SR	PR	CR	C = #6 CU-AL
	3	LR25030-3	SR	PR	CR	
60	1	LR25060-1			CR	S = #10 CU
	2	LR25060-2			CR	C = #2 CU-AL
	3	LR25060-3			CR	
100	1	LR25100-1			C	
	2	LR25100-2			C	#2/0 CU-AL
	3	LR25100-3			C	
200	1	LR25200-1			C	
	3	LR25200-3			C	250 MCM CU-AL
	1	LR25400-1			CR	
400	3	LR25400-3			CR	(2) 350 MCM CU-AL
	1	LR25600-1			C	
	3	LR25600-3			C	(2) 500 MCM CU-AL

Note: Reinforcing springs standard on all Class R fuse blocks.

Class H 600V

Amp Rating	No. of Poles	Catalog Number	Connector Type (Add Suffix Shown)			Maximum Wire Size
			Screw	Pressure Plate	Box Lug	
30	1	LH60030-1	S (R)	P (R)	C (R)	S & P = #10 CU
	2	LH60030-2	S (R)	P (R)	C (R)	C = #6 CU-AL
	3	LH60030-3	S (R)	P (R)	C (R)	
60	1	LH60060-1			C (R)	S = #10 CU
	2	LH60060-2			C (R)	C = #2 CU-AL
	3	LH60060-3			C (R)	
100	1	LH60100-1			C	
	2	LH60100-2			C	#2/0 CU-AL
	3	LH60100-3			C	
200	1	LH60200-1			C	
	3	LH60200-3			C	250 MCM CU-AL
	1	LH60400-1			CR	
400	3	LH60400-3			CR	(2) 350 MCM CU-AL
	1	LH60600-1			C	
	3	LH60600-3			C	(2) 500 MCM CU-AL

Note: Reinforcing springs standard on all Class H fuse blocks 100 amperes and above.

Class R 600V

Amp Rating	No. of Poles	Catalog Number	Connector Type (Add Suffix Shown)			Maximum Wire Size
			Screw	Pressure Plate	Box Lug	
30	1	LR60030-1	SR	PR	CR	S & P = #10 CU
	2	LR60030-2	SR	PR	CR	C = #6 CU-AL
	3	LR60030-3	SR	PR	CR	
60	1	LR60060-1			CR	S = #10 CU
	2	LR60060-2			CR	C = #2 CU-AL
	3	LR60060-3			CR	
100	1	LR60100-1			C	
	2	LR60100-2			C	#2/0 CU-AL
	3	LR60100-3			C	
200	1	LR60200-1			C	
	3	LR60200-3			C	250 MCM CU-AL
	1	LR60400-1			CR	
400	3	LR60400-3			CR	(2) 350 MCM CU-AL
	1	LR60600-1			C	
	3	LR60600-3			C	(2) 500 MCM CU-AL

Note: Reinforcing springs standard on all Class R fuse blocks.

Class H/K5 and R Fuse Blocks

250 Volt

250V 30A

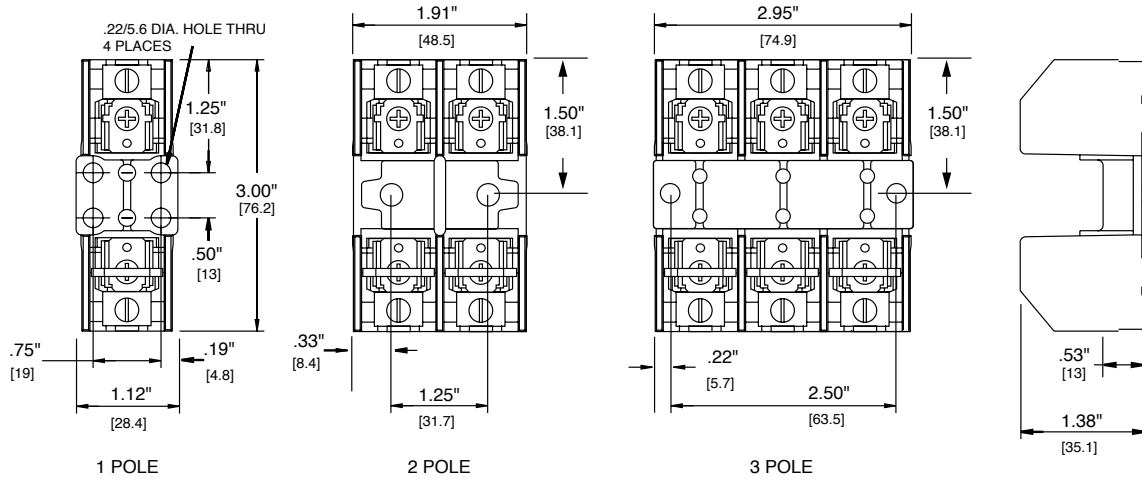

250V 60A

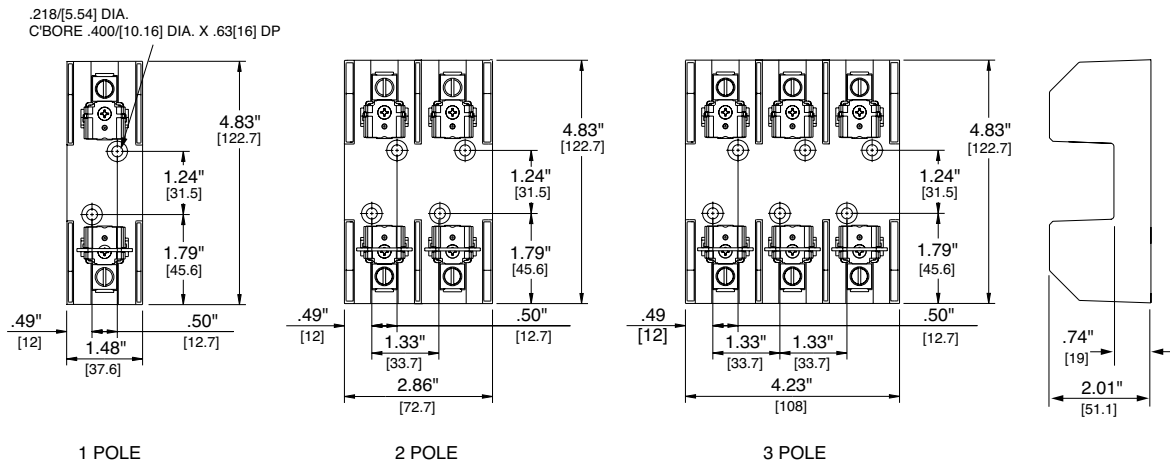

250V 100A

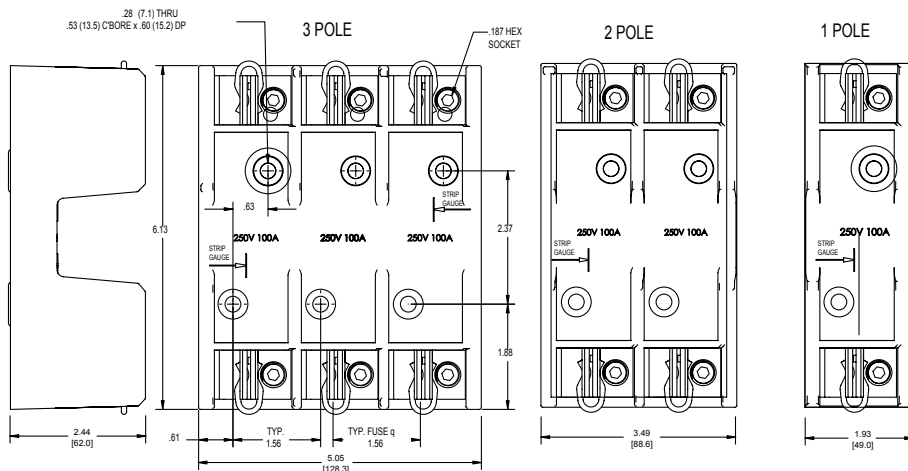

Class H/K5 and R Fuse Blocks

250 Volt

250V 200A

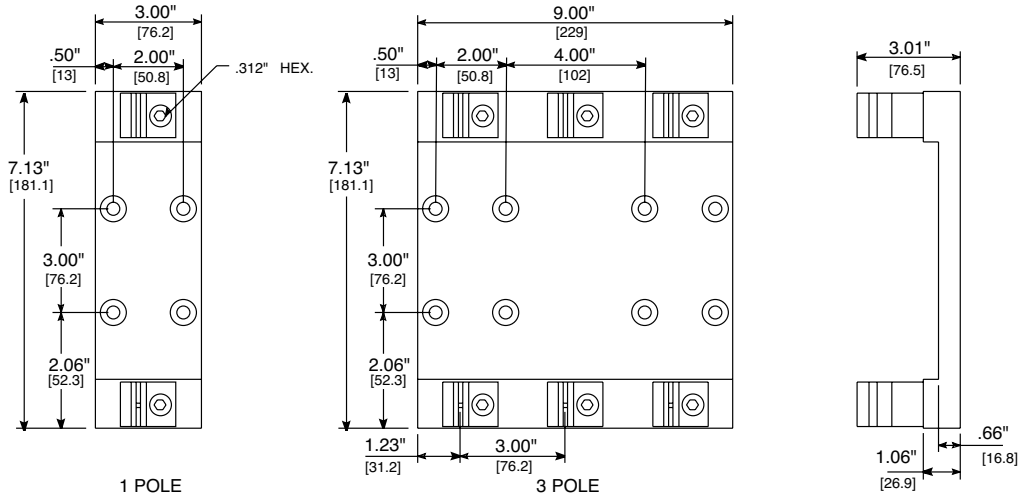

250V 400A

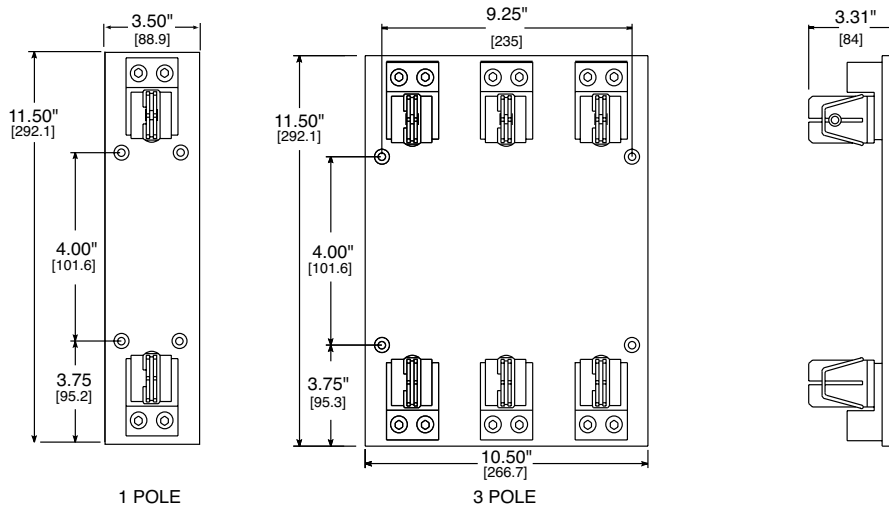

250V 600A

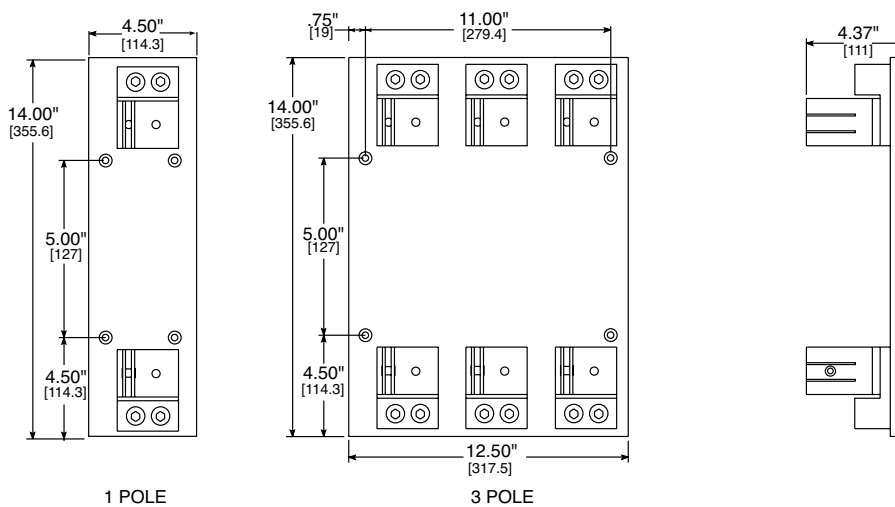

Class H/K5 and R Fuse Blocks

600 Volt

600V 30A

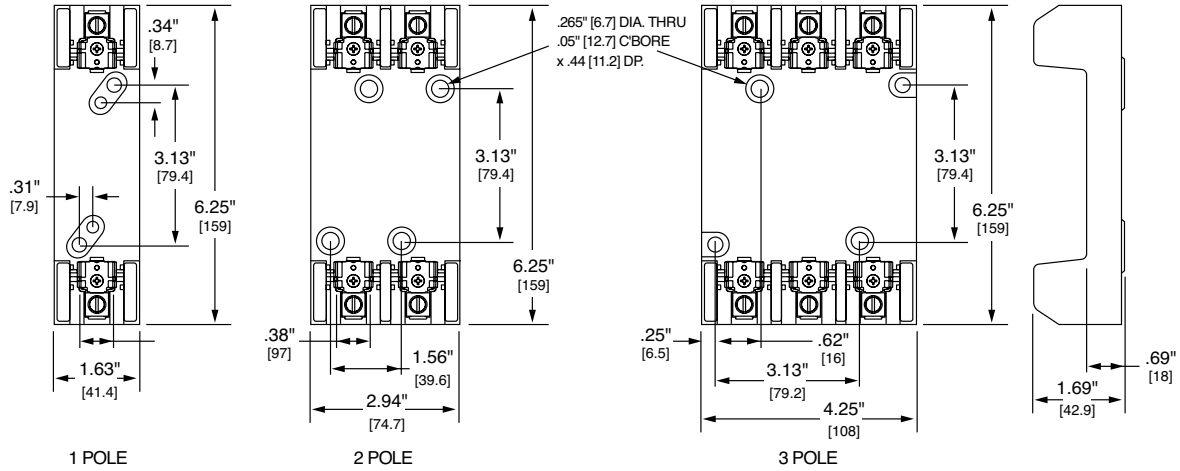

600V 60A

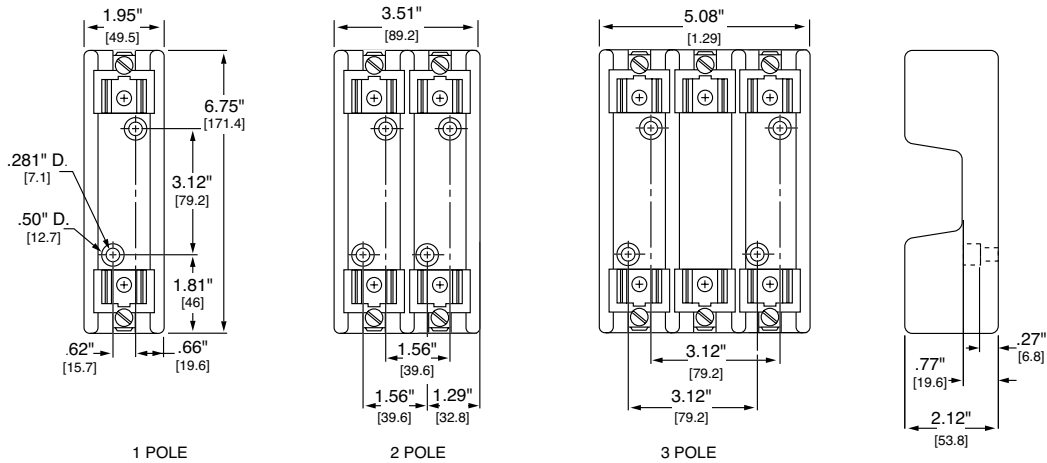

600V 100A

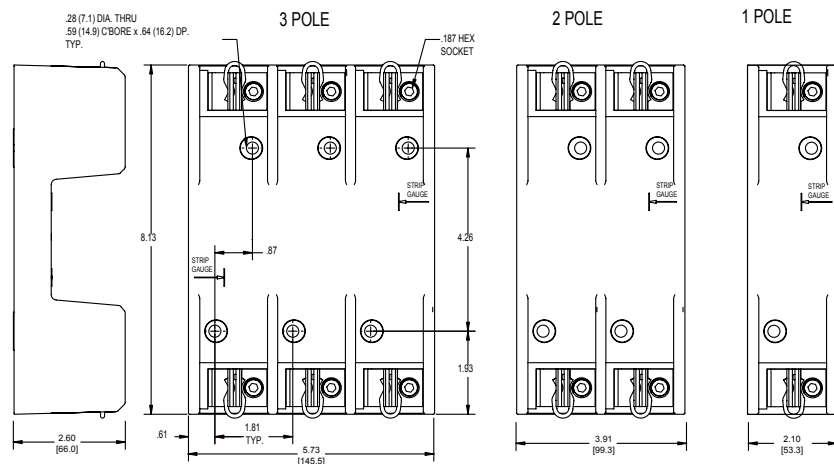

Class H/K5 and R Fuse Blocks

600 Volt

600V 200A

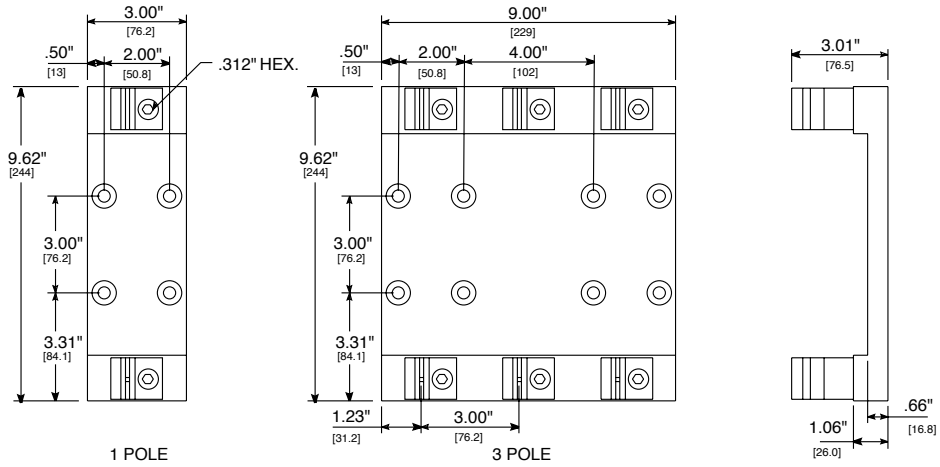

600V 400A

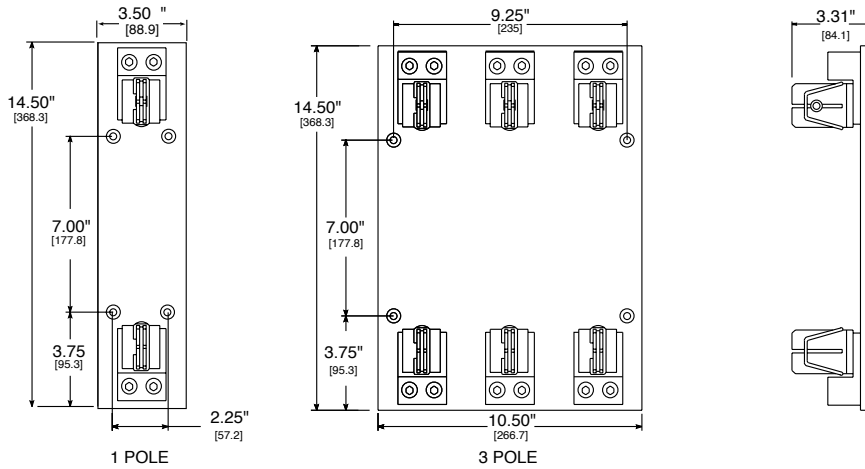

600V 600A

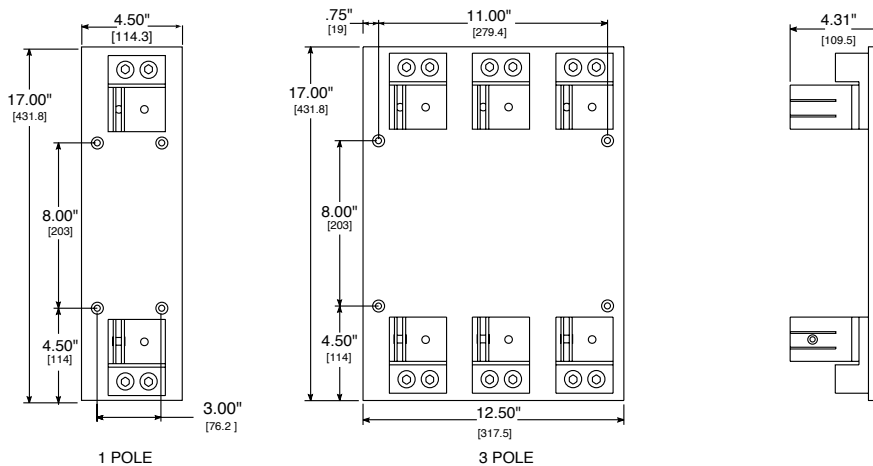

Class J Fuse Blocks

600 Volt



Class J 600V

Amp Rating	No. of Poles	Catalog Number	Connector Type (Add Suffix Shown)			Maximum Wire Size
			Screw	Pressure Plate	Box Lug	
30	1	LJ60030-1	S (R)	P (R)	C (R)	S & P = #10 CU C = #6 CU
	2	LJ60030-2	S (R)	P (R)	C (R)	
	3	LJ60030-3	S (R)	P (R)	C (R)	
	Adder	LJ60030-A	S (R)	P (R)	C (R)	
60	1	LJ60060-1			C (R)	C = #2 CU-AL
	2	LJ60060-2			C (R)	
	3	LJ60060-3			C (R)	
100	1	LJ60100-1			CR	#2/0 CU-AL
	3	LJ60100-3			CR	
200	1	LJ60200-1			C	250 MCM CU-AL
	3	LJ60200-3			C	
400	1	LJ60400-1			CR	(2) 350 MCM CU-AL
	3	LJ60400-3			CR	
600	1	LJ60600-1			CR	(2) 500 MCM CU-AL
	3	LJ60600-3			CR	

Note: Reinforcing springs standard on all Class J fuse blocks rated 100A and above.

*For optional fuse block covers, refer to POWR-Covers section of this catalog. For reinforcing clips on blocks rated 30-60 amp, add "R" suffix to connector type.

Features/Benefits

- Phenolic blocks have side barriers for isolation.
- Spring reinforced fuse clips are standard on 100A and larger blocks. Reinforcing springs are optional on 30 and 60 amp blocks.
- **Space saving 30A design** — Up to 45% smaller than existing 30A fuse blocks. 30A interlocking adder block available to create any number of poles (consult factory for availability). Integral DIN rail mount allows this block to be securely fastened to 35 mm "hat" type DIN rails without the use of tools.

Specifications

- Voltage Ratings:** 600 Volts
- Ampere Ratings:** 0 – 600 amperes
- Approvals:** UL Listed: File No. E14721
CSA Certified: File No. LR73091

Recommended Fuses

JTD_ID/JTD (time-delay) and JLS (fast acting) series fuses

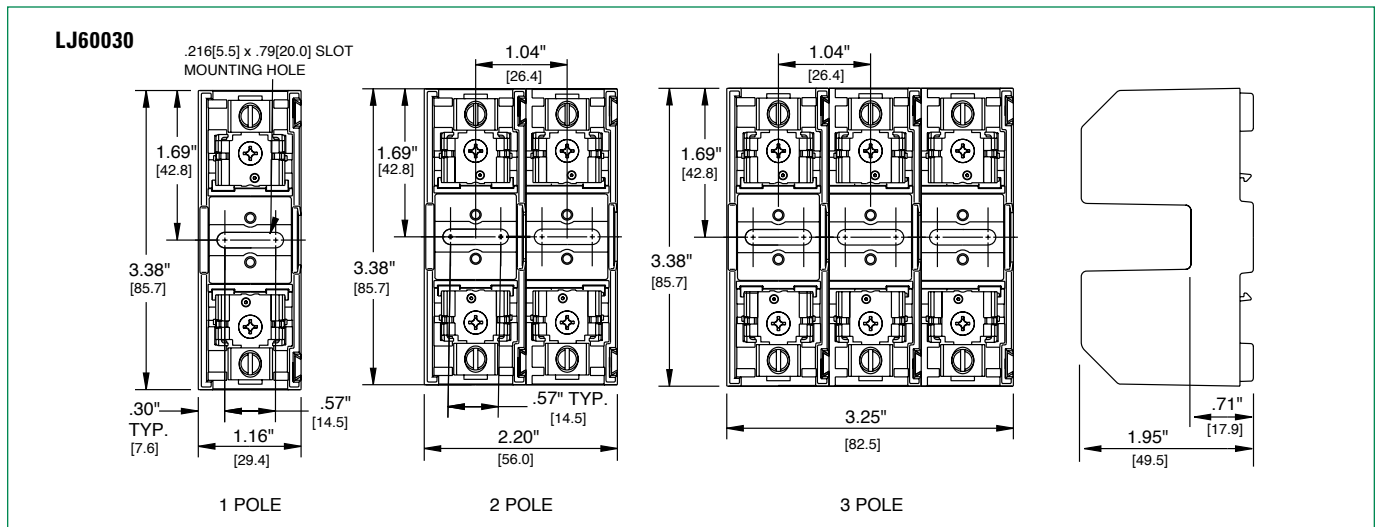

Class J Fuse Blocks

600 Volt

LJ60060

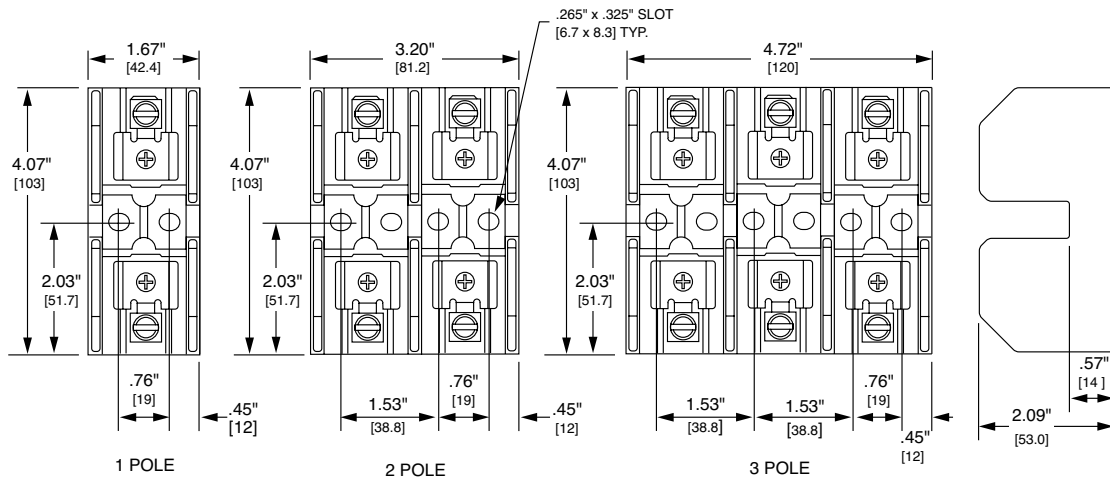

LJ60100

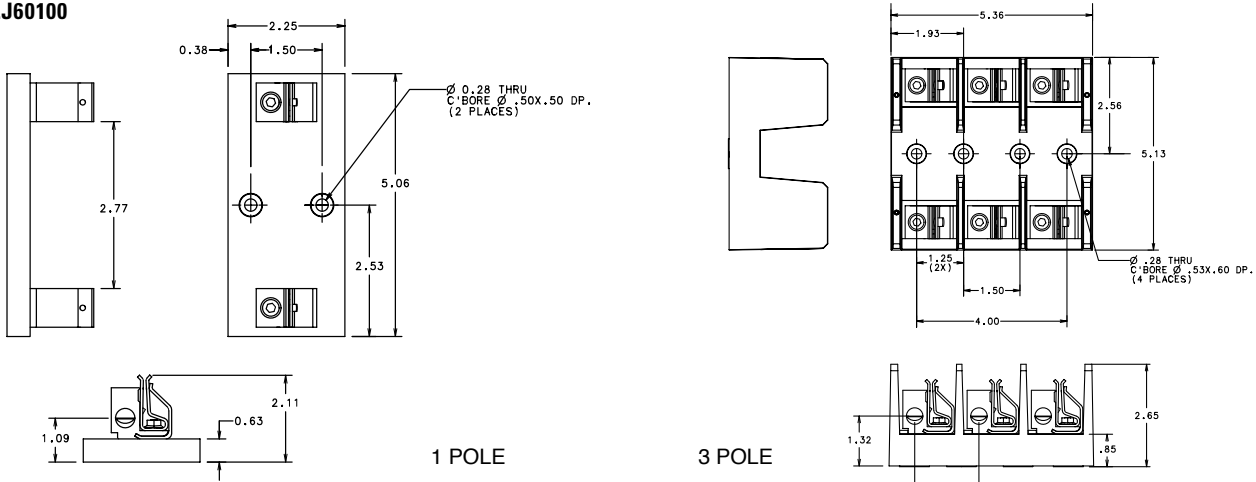

LJ60200

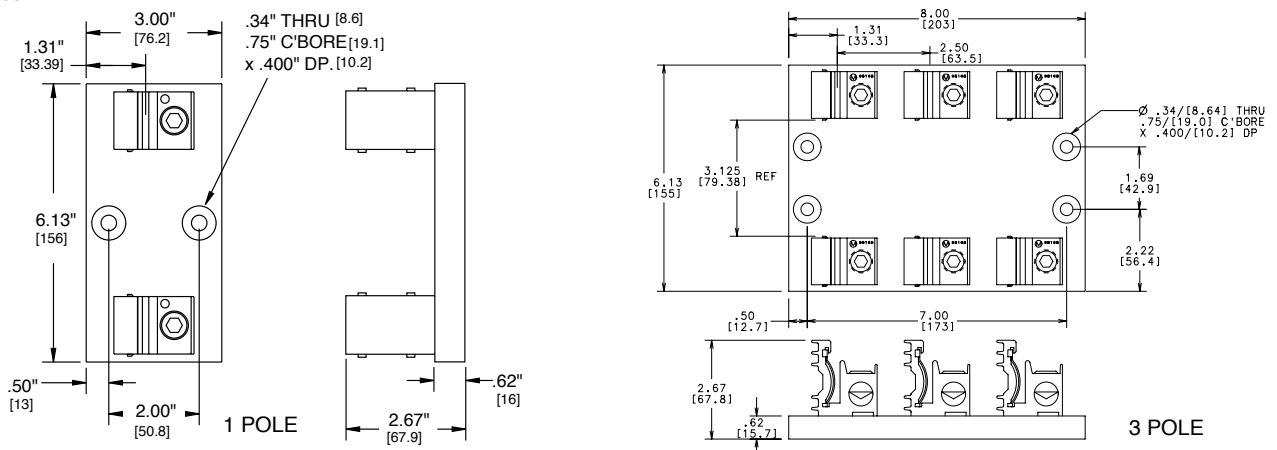

Class J Fuse Blocks

600 Volt

LJ60400

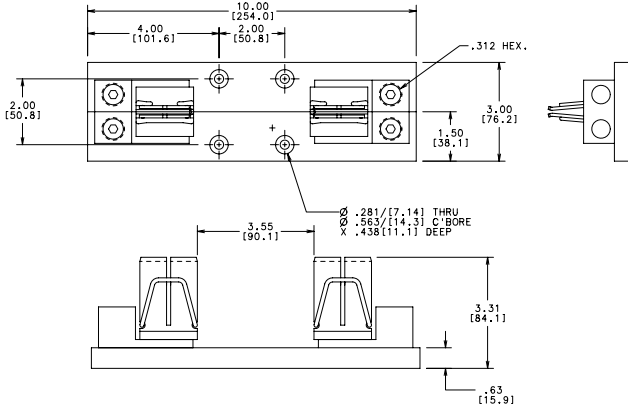

1 POLE

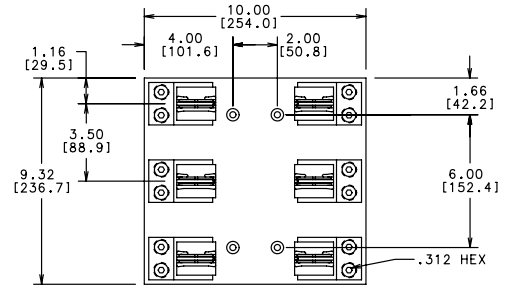

3 POLE

LJ60600

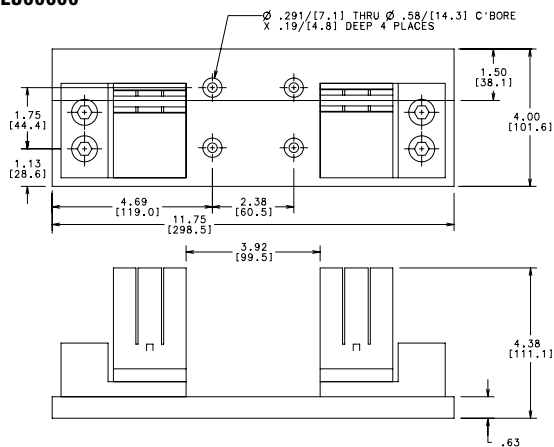

1 POLE

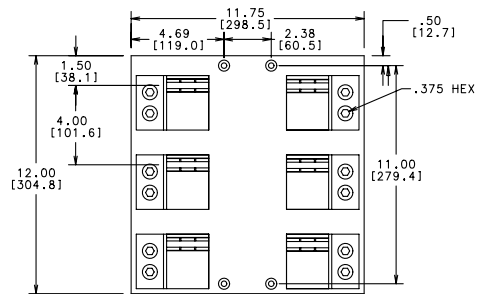

3 POLE

Class T Fuse Blocks

300 and 600 Volt



Features/Benefits

Bases are molded phenolic. To provide a low resistance connection and long-range reliability, steel reinforcing springs are supplied as standard. Larger blocks employ an integral heat sink for maximum heat dissipation.

Specifications

- Voltage Ratings:** 300 Volts AC
600 Volts AC
- Ampere Ratings:** 0 – 600 amperes
- Approvals:** UL Listed (File No. E14721)
CSA Certified (File No. LR73091)

Recommended Fuses

JLLN (300V) and JLLS (600V) series fuses
300 and 600 volt fuse blocks are designed for use with miniaturized Class T fuses. Class T fuses are very fast acting, current-limiting, and approximately one-third the size of electrically comparable Class RK1 fuses.

Class T 300V

Amp Rating	No. of Poles	Catalog Number	Connector Type (Add Suffix Shown)		Maximum Wire Size
			Screw	Box Lug	
30	2	LT30030-2		CR	S = #10 CU
	3	LT30030-3		CR	C = #2 CU
60	2	LT30060-2		CR	C = #2 CU-AL
	3	LT30060-3		CR	
	4	LT30060-4		CR	
100	1	LT30100-1		C	#2/0 CU-AL
	2	LT30100-2		C	
	3	LT30100-3		C	
200	1	LT30200-1		C	250 MCM CU-AL
400	1	LT30400-1		C	(2) 250 MCM CU-AL
600	1	LT30600-1		C	(2) 500 MCM CU-AL

Note: Reinforcing springs standard on all 300 volt Class T fuse blocks up to 100 amperes. 300 volt Class T blocks 200 amperes and larger have stud mountings.

Class T 600V

Amp Rating	No. of Poles	Catalog Number	Connector Type (Add Suffix Shown)		Maximum Wire Size
			Screw	Box Lug	
30	1	LT60030-1	SR	CR	S = #10 CU
	2	LT60030-2	SR	CR	C = #2 CU-AL
	3	LT60030-3	SR	CR	
60	1	LT60060-1		CR	C = #2 CU-AL
	2	LT60060-2		CR	
	3	LT60060-3		CR	
100	1	LT60100-1		C	#2/0 CU-AL
	2	LT60100-2		C	
	3	LT60100-3		C	
200	1	LT60200-1		C	250 MCM CU-AL
400	1	LT60400-1		C	(2) 250 MCM CU-AL
600	1	LT60600-1		C	(2) 500 MCM CU-AL

Note: Reinforcing springs standard on all 600 volt Class T fuse blocks up to 60 amperes. 600 volt Class T blocks 100 amperes and larger have stud mountings.

LT30030

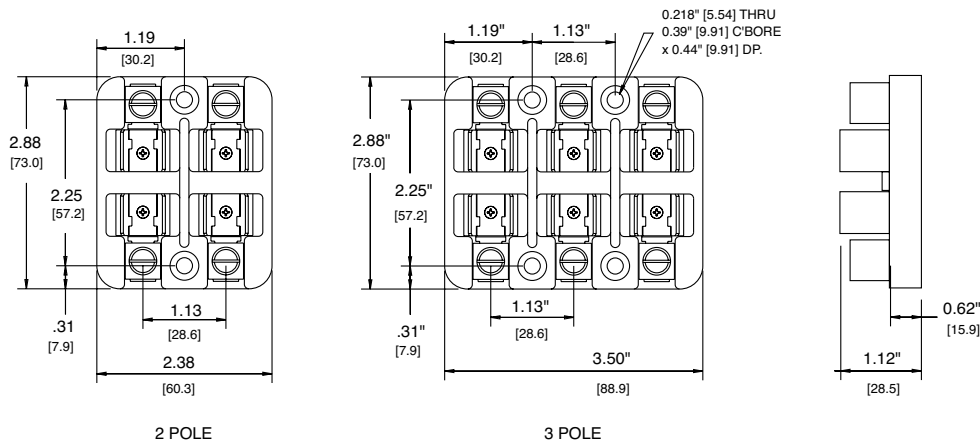

Class T Fuse Blocks

300 Volt

LT30060

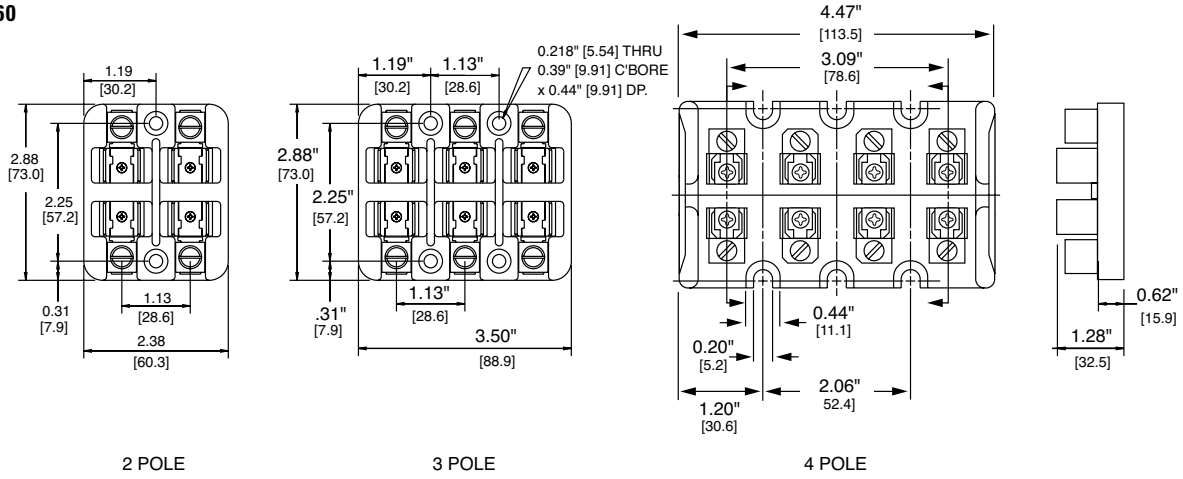

LT30100

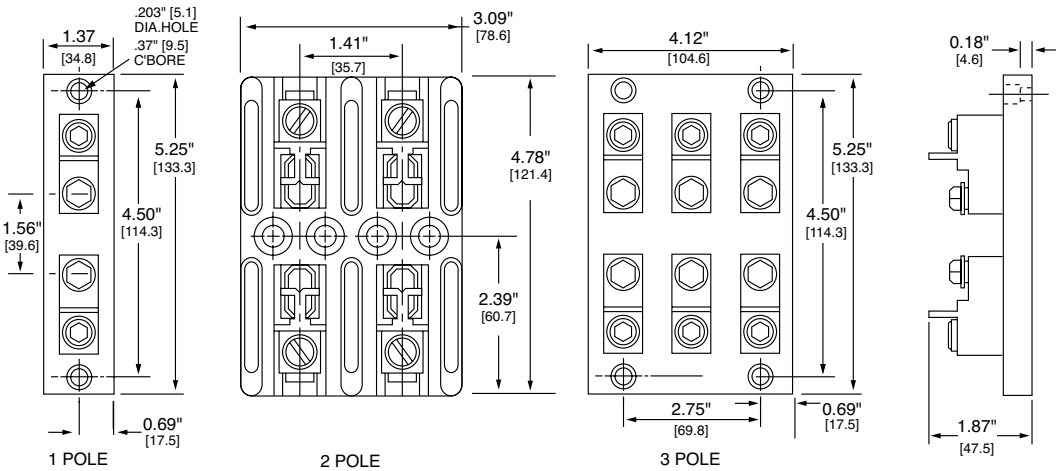

LT30200

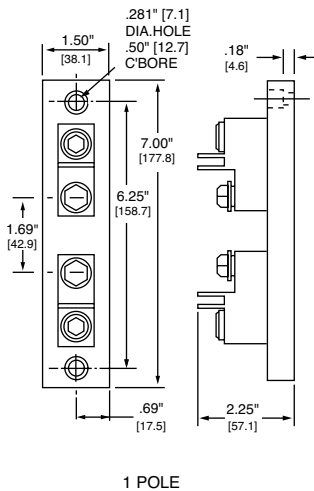

LT30400

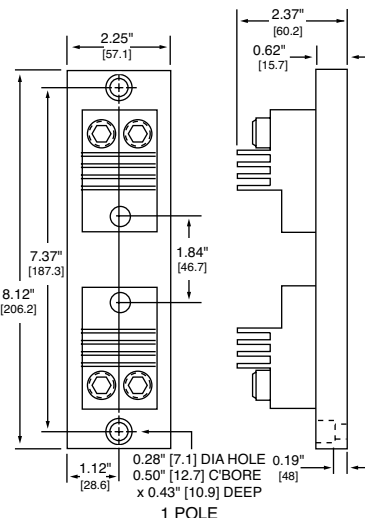

LT30600

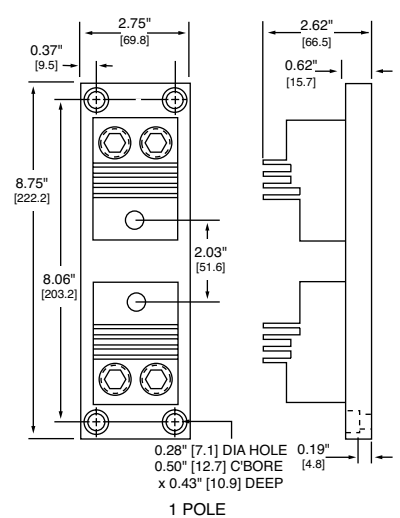

Class T Fuse Blocks

600 Volt

LT60030

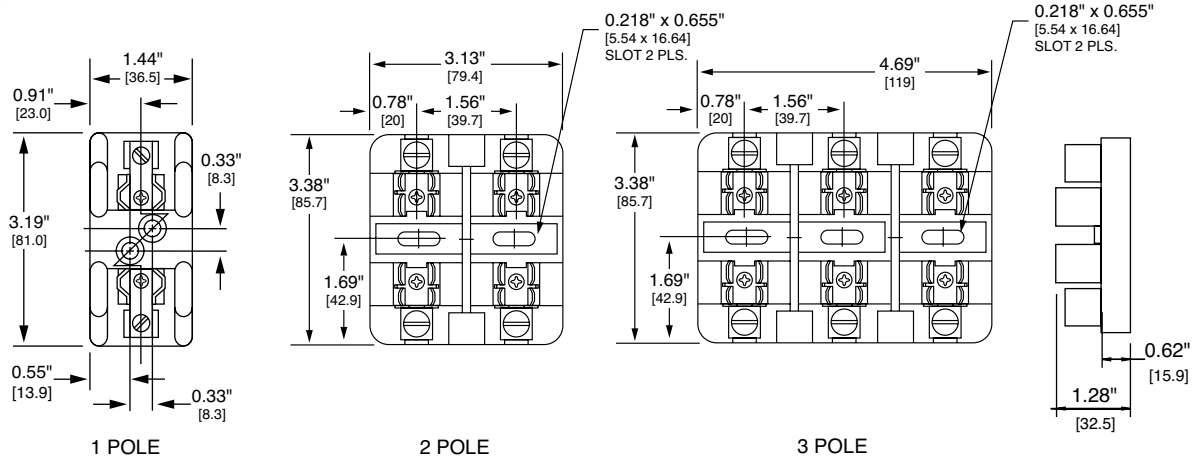

LT60060

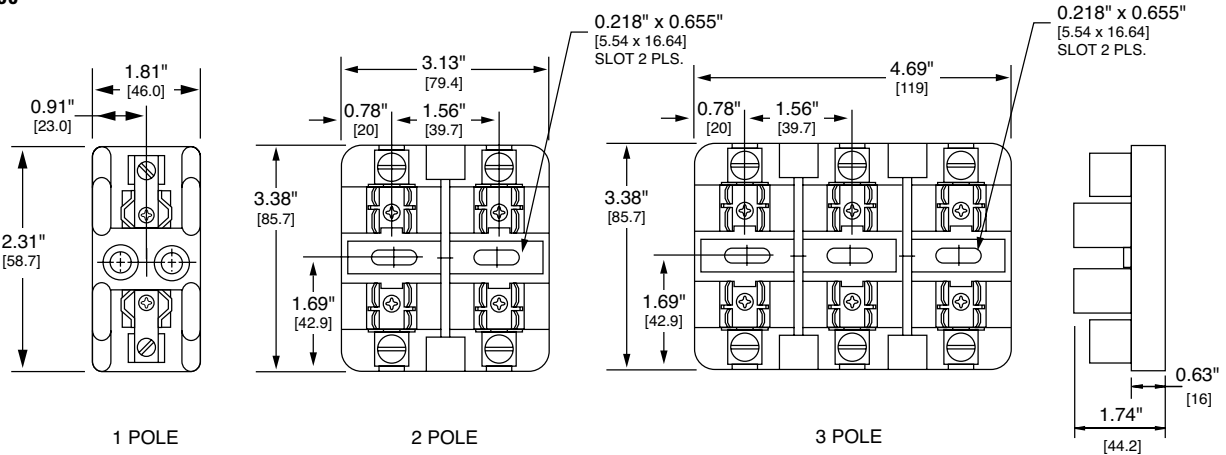

LT60100

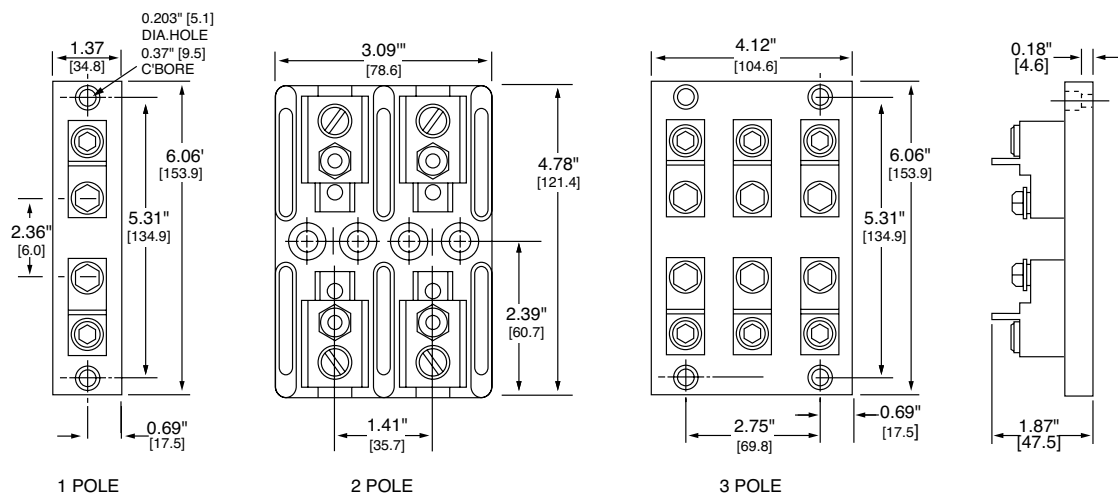

Class T Fuse Blocks

600 Volt

LT60200

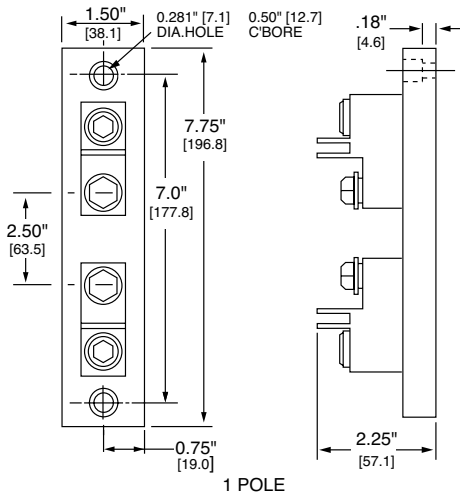

LT60400

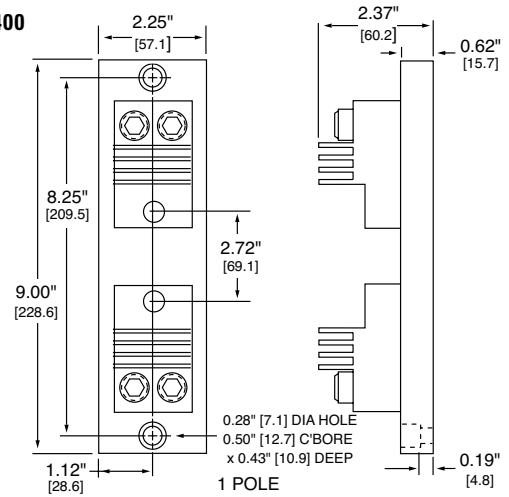

LT60600

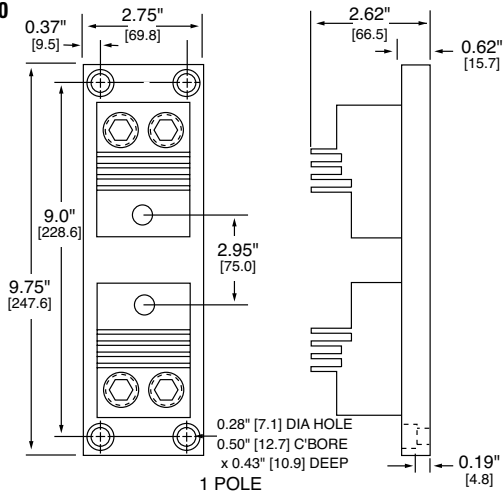

Class G Fuse Blocks



Class G fuse blocks are designed for use with 480 volt time-delay, current-limiting Class G fuses. They meet requirements for branch circuit protection.

Specifications

- Voltage Ratings:** 600 Volts AC (0 – 20A)
480 Volts AC (25 – 60A)
- Ampere Ratings:** 0 – 60 amperes
- Approvals:** UL Listed: 15, 20 & 30A (File No. E14721)
60A (File No. E14853)
CSA Certified: 15, 20 & 30A (File No. LR7316)
60A (File No. LR47235)

Recommended Fuses

SLC series fuses

Amp Rating	No. of Poles	Catalog Number	Connector Type (Add Suffix Shown)			Maximum Wire Size
			Screw	Pressure Plate	Box Lug	
15*	1	LG30015-1	SQ			#10 CU
	2	LG30015-2	SQ			
	3	LG30015-3	SQ			
20*	1	LG30020-1	SQ			#10 CU
	2	LG30020-2	SQ			
	3	LG30020-3	SQ			
30*	1	L30030G-1	SQ	PQ		#10 CU
	2	L30030G-2	SQ	PQ		
	3	L30030G-3	SQ	PQ		
60	1	LG30060-1			CR	#2 CU-AL
	2	LG30060-2			CR	
	3	LG30060-3			CR	

* Note: 15, 20 & 30A Class G fuse blocks are equipped with 20A Quick Connect Terminals. 60A fuse block equipped with reinforcing spring as standard.

LG30015 & LG30020

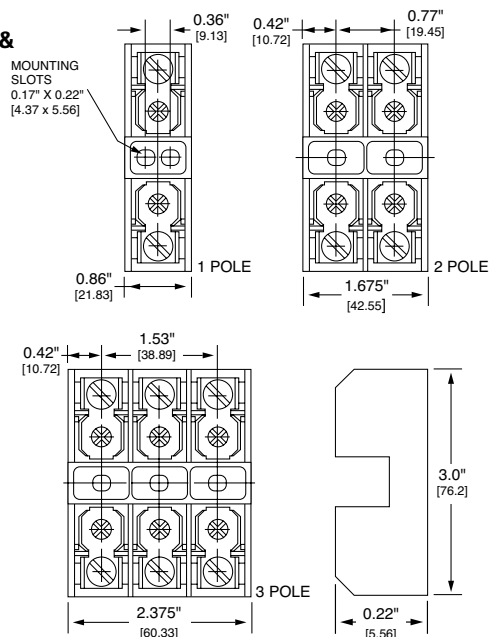

LG30060

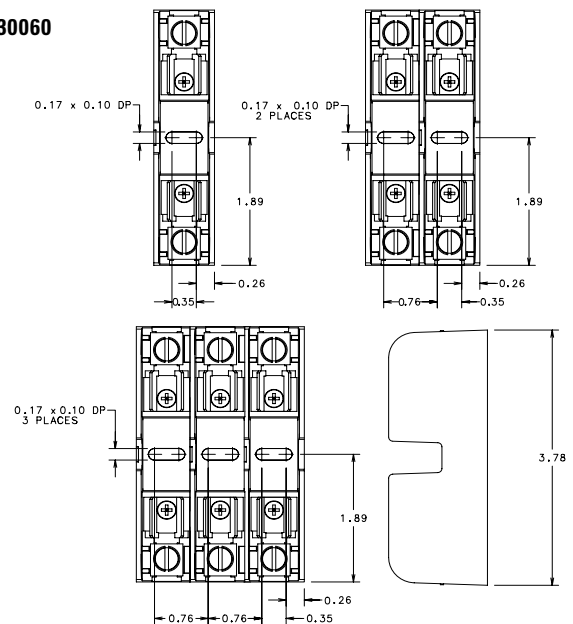

Note: Refer to the Midget/Class CC Fuse Blocks for L30030G 30A Class G Block dimensions.

Class CC/CD and Midget Fuse Blocks

600 Volt



Space saving 600 volt, 30 amp molded case fuse blocks with side barriers for isolation. Class CC blocks and Midget blocks are identical except Class CC blocks incorporate a rejection feature to assure proper fusing.

Safety

- Rejection feature — Class CC fuse blocks have a rejection feature which prevents the insertion of fuses with lower interrupting rating or voltage ratings. Class CC fuses are rated 600 volts and have an

interrupting rating of 200,000 amperes. Midget fuse voltage ratings vary and their interrupting rating may be as low as 10,000 amperes. *Note that Class CC fuses may be used in Midget fuse blocks, but Midget fuses cannot be used in Class CC blocks.*

Long life

- High-strength materials — Class CC and Midget fuse blocks are molded of high-strength, high-temperature material to minimize block breakage during handling and installation, as well as damage caused by overheating.
- Reduced resistance, less heat — High conductivity, one-piece copper alloy fuse clips have lower resistance than traditional two-piece brass or phosphor bronze fuse clips, which minimizes heat rise and watts loss within the fuse block.

Reduced inventory

- Gangable — Interlocking fuse blocks allow ganging to produce a fuse block with any number of poles.
- Flexible terminal arrangements — 30A Class CC and Midget fuse blocks are available with type C box lug, type SQ screw, or type PQ pressure plate terminals. Type SQ terminals have binding-head screws, while type PQ terminals have captive pressure plates. Both terminal types can accommodate side or top mounted quick-connect terminals. This flexibility allows the accommodation of most needs and reduces part inventory requirements.
- 60A CD fuse blocks are available with type C box lug terminals.
- DIN rail mountable — FBDIN1 adapters permit snap-mounting Littelfuse Class CC and Midget 30 amp fuse blocks directly to standard or low profile 35mm symmetrical “hat” and 32mm asymmetrical DIN rails. Patented DIN rail adapters snap securely to Littelfuse fuse blocks and to DIN rails without tools. They can be readily removed from rails by lifting the disconnect tab.
- L60060C 60A fuse blocks have patented integral DIN rail adapters which allow direct mounting to 35mm “hat” type DIN rails.

Specifications

Voltage Rating:	600 Volts AC/600 Volts DC
Ampere ratings:	L60030C: 30 amps L60030M: 30 amps L60060C: 60 amps
Dielectric strength:	1200 volts minimum
Clip/terminals:	Tin-plated copper alloy
Box lug:	Copper
Screw and captive pressure plate:	Zinc-plated steel
Base:	Thermoplastic. UL 94V0 flammability rating.
Approvals:	Class CC: UL Listed (File No. E14721) Midget: UL Recognized (File No. E14721) Class CC/Midget: CSA Certified (File No. LR7316)

Recommended Fuses

Class CC Blocks:

CCMR | KLDR | KLKR

Midget Blocks:

BLF | BLS | FLM | FLU | KLKD | LA60Q-2
BLN | FLA | FLQ | KLK | KLO

Class CD Blocks:

CCMR

Note: L60030M can be used up to 40A.

Class CC/CD and Midget Fuse Blocks

600 Volt

Class CC 30A Fuse Blocks

Amp Rating	No. of Poles	Catalog Number	Connector Type (Add Suffix Shown)	Maximum Wire Size
30	1	L60030C-1C	Box Lug	#6 CU
	2	L60030C-2C		
	3	L60030C-3C		
30	1	L60030C-1PQ	Pressure Plate/ Q. C. Terminal	#10 CU
	2	L60030C-2PQ		
	3	L60030C-3PQ		
30	1	L60030C-1SQ	Screw/ Q. C. Terminal	#10 CU
	2	L60030C-2SQ		
	3	L60030C-3SQ		

Class CD 60A Fuse Blocks

Amp Rating	No. of Poles	Catalog Number	Connector Type (Add Suffix Shown)	Maximum Wire Size
60	1	L60060C-1C	Box Lug	#6 CU
	2	L60060C-2C		
	3	L60060C-3C		
60	Adder Block	L60060C-AC	Box Lug	#6 CU

Note: Quick Connect Terminals are rated at 20 amperes.

Midget Fuse Blocks

Amp Rating	No. of Poles	Catalog Number	Connector Type (Add Suffix Shown)	Maximum Wire Size
30	1	L60030M-1C	Box Lug	#6 CU
	2	L60030M-2C		
	3	L60030M-3C		
30	1	L60030M-1PQ	Pressure Plate/ Q. C. Terminal	#10 CU
	2	L60030M-2PQ		
	3	L60030M-3PQ		
30	1	L60030M-1SQ	Screw/ Q. C. Terminal	#10 CU
	2	L60030M-2SQ		
	3	L60030M-3SQ		

Note: Quick Connect Terminals are rated at 20 amperes.

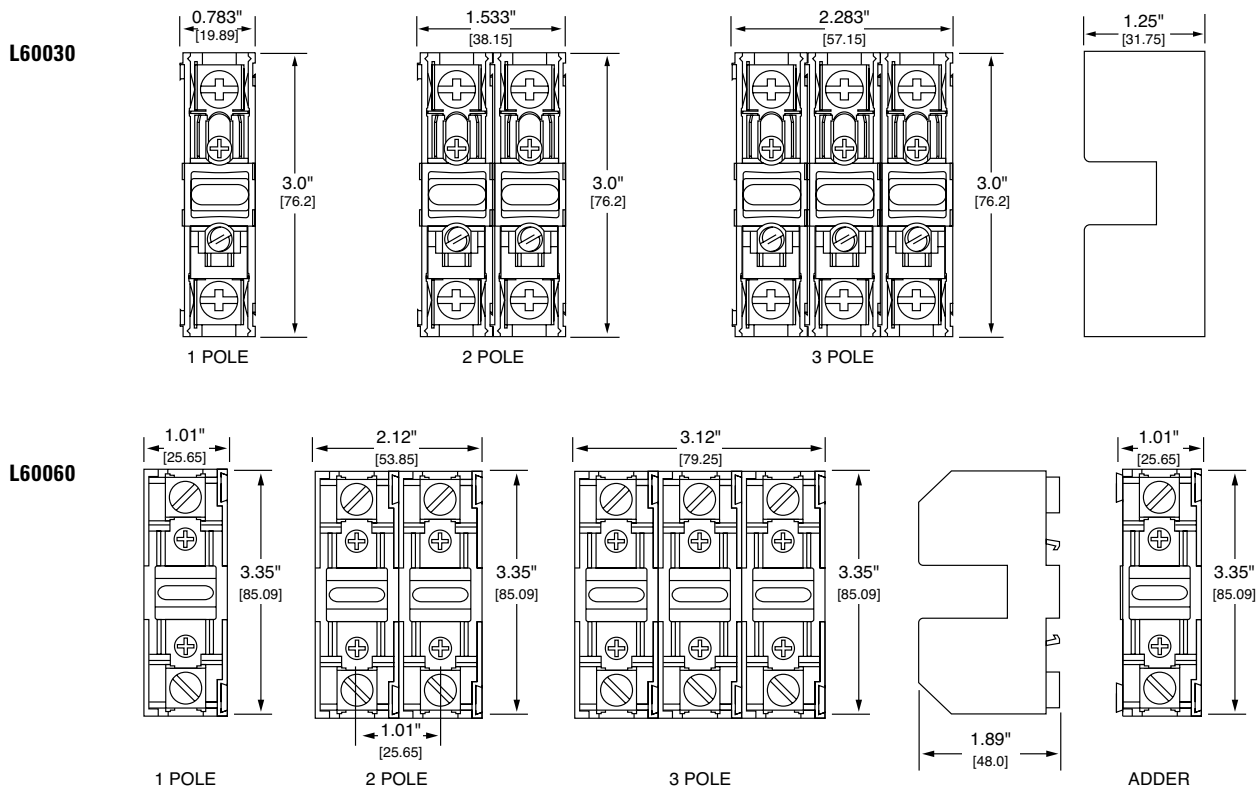

Class CC and Midget Fuse Block Accessories

DIN Rail Adapters and Cover Pullers

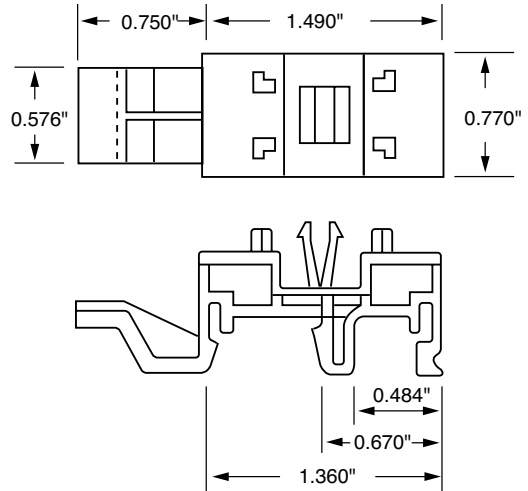
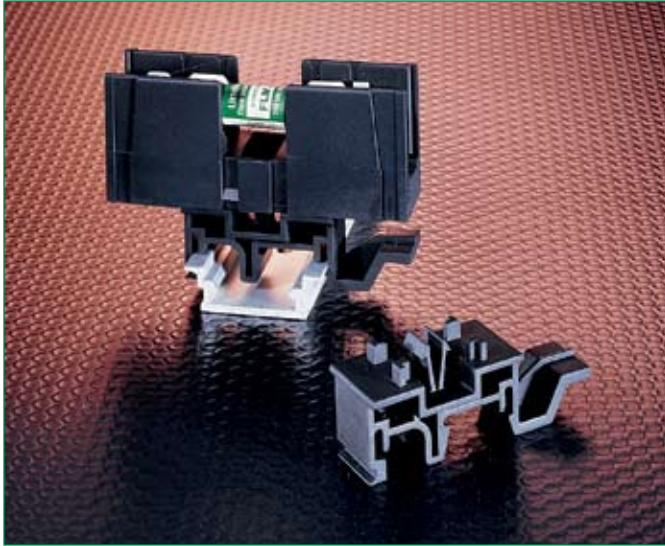

DIN Rail Adapter — FBDIN1

FBDIN1 is for use with 30A Midget, Class CC and Class G fuse blocks. The patented design permits snap-mounting of Littelfuse Class CC and Midget 30A fuse blocks directly to standard and low profile 35mm symmetrical "hat" and 32mm asymmetrical DIN rails. Adapters snap securely to Littelfuse fuse blocks and to DIN rails without tools. They may be readily removed from rails by lifting the disconnect tab.

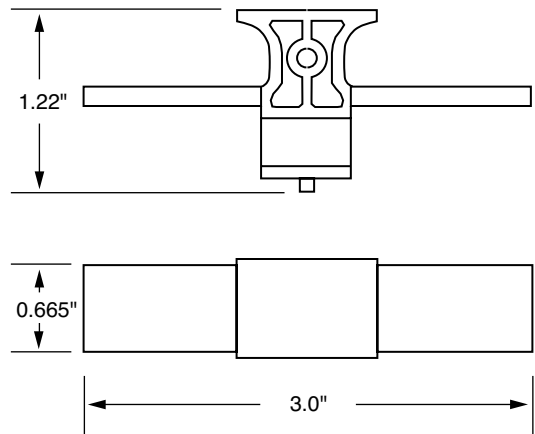
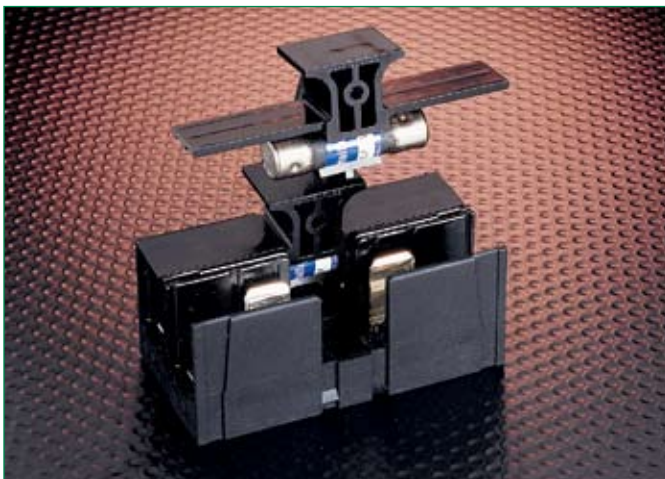
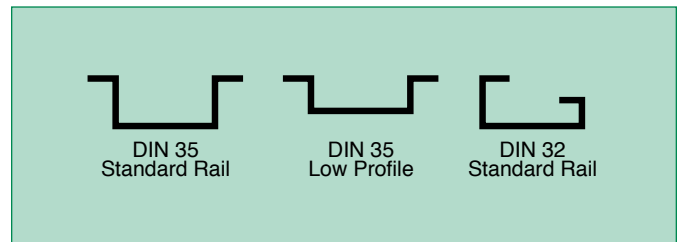

Cover Puller — SPL001

Littelfuse Class CC and Midget fuse cover puller is designed to provide protection to personnel, as well as make removal of fuses from fuse blocks easy and safe. Once installed on the fuse, the cover puller allows removal of the fuse without the use of a separate puller.

- Meets "Dead Front" requirements for use in control panels.
- Permits safe, easy removal.
- Works with existing fuse block. No special hinged fuse blocks are required.
- Easily gangable with 1/8" diameter wire.
- For use with all 600 volt Class CC and Midget 1/10 — 30A fuses.
- Use with Class CC L60030C series and L60030M series fuse blocks.
- Label provided for easy fuse identification.
- For 2-pole cover puller, order DSPL001.

Fuse Blocks, Holders and Accessories

POWR-SAFE "Dead Front" Holders



Littelfuse POWR-SAFE "Dead Front" holders provide optimum protection to personnel. Indicating and non-indicating versions are available in 1, 2, 3, or 4 poles for Class CC and Midget fuses.

Dimensions in inches (mm in parentheses)

- LPSM/LPSC POWR-SAFE Holders

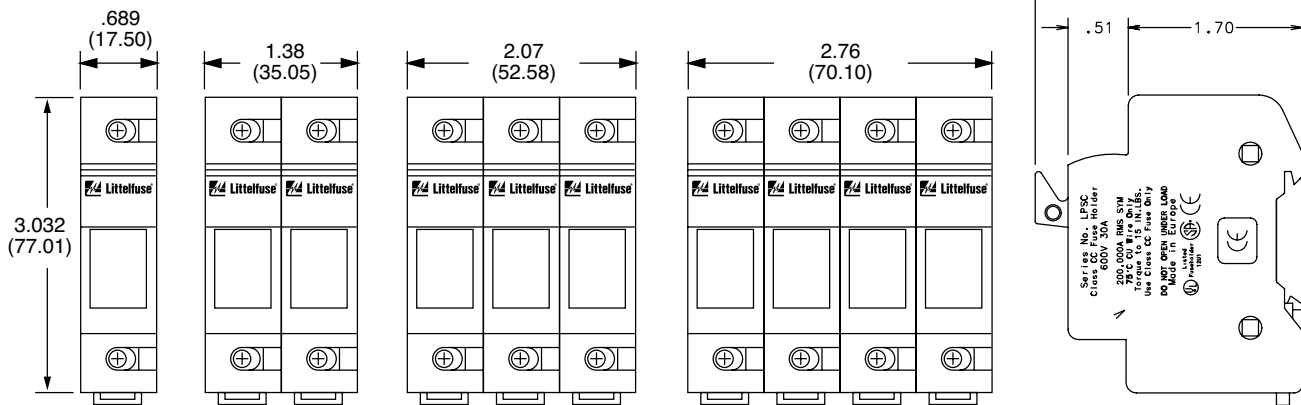

Features/benefits

- Meets "Dead Front" requirements and IEC Type IP20 Protection
- Mountable on 35mm Din Rail
- Blown fuse identification (Indicating versions only)
- Easy installation and removal of fuses. No special fuse pullers or tools required.
- UL Listed for branch circuit protection (Class CC versions only)
- Compact design
- Ventilated design for cooler operation
- Indicates above 80 volts (ID versions only)

Ordering information

Indicating Part Number	Non-Indicating Part Number	Fuse Type	Number of Poles
LPSC001ID	LPSC001	Class CC	1
LPSC002ID	LPSC002	Class CC	2
LPSC003ID	LPSC003	Class CC	3
LPSC004ID	LPSC004	Class CC	4
LPSM001ID	LPSM001	Midget	1
LPSM002ID	LPSM002	Midget	2
LPSM003ID	LPSM003	Midget	3
LPSM004ID	LPSM004	Midget	4

Multi-pole Assembly Kit: Order No: CYHP001
(Kit contains 20 connector pincers and 10 handle pins.)

NOTE: Contact factory for DC rated versions.

Specifications

Voltage Rating: 600 Volts AC/DC
Ampere Rating: 30 amperes
Interrupting Rating: 200 kA (Class CC)
 100 kA (Midget)
Terminal type: Pressure plate
Suggested Torque: 15 lb.
Wire Range: #6—#14CU

Material: Thermo-Plastic
Flammability Rating: 94V0
Approvals: UL Listed (LPSC File No: E14721)
 UL Recognized (LPSM File No: E14721)
 CSA Certified (LPSC/LPSM File No: LR7316)
 IEC Type IP20 Protection
 CE Certified

Fuse Blocks, Holders and Accessories

Class J POWR-SAFE Holders



Littelfuse POWR-SAFE “Dead Front” fuseholders provide optimum protection to personnel. An integral DIN-Rail adapter system allows fuse holders to be mounted on 35mm DIN-Rail without the use of tools or special parts. Indicating and non-indicating versions are available in 1, 2, or 3 poles for Class J fuses.

Features/benefits

- Meets “Dead Front” requirements and IEC Type IP20 protection.
- Mountable on 35mm DIN-Rail.
- Blown fuse identification (Indicating versions only).
- Easy installation and removal of fuses. No special fuse pullers or tools required.
- UL listed for branch circuit protection.
- Ventilated design for cooler operation.

Ordering Information

Littelfuse Catalog No.	Littelfuse System No.	No. of Poles	Pack Qty.	Voltage Rating	Ampere Rating	Options
LPSJ30-1	LPSJ301.Z	1	6	600V	30A	–
LPSJ30-2	LPSJ302.Z	2	3	600V	30A	–
LPSJ30-3	LPSJ303.Z	3	2	600V	30A	–
LPSJ30-1ID	LPSJ301.ZXID	1	6	600V	30A	Indicating
LPSJ30-2ID	LPSJ302.ZXID	2	3	600V	30A	Indicating
LPSJ30-3ID	LPSJ303.ZXID	3	2	600V	30A	Indicating
LPSJ60-1	LPSJ601.Z	1	6	600V	60A	–
LPSJ60-2	LPSJ602.Z	2	3	600V	60A	–
LPSJ60-3	LPSJ603.Z	3	2	600V	60A	–
LPSJ60-1ID	LPSJ601.ZXID	1	6	600V	60A	Indicating
LPSJ60-2ID	LPSJ602.ZXID	2	3	600V	60A	Indicating
LPSJ60-3ID	LPSJ603.ZXID	3	2	600V	60A	Indicating

Multi-Pole Assembly Kit: Order No: US3J2PAK to assemble two LPSJ30-1
 US3J3PAK to assemble three LPSJ30-1
 US6J2PAK to assemble two LPSJ60-1
 US6J3PAK to assemble three LPSJ60-1

Dimensions in inches (mm in parentheses)

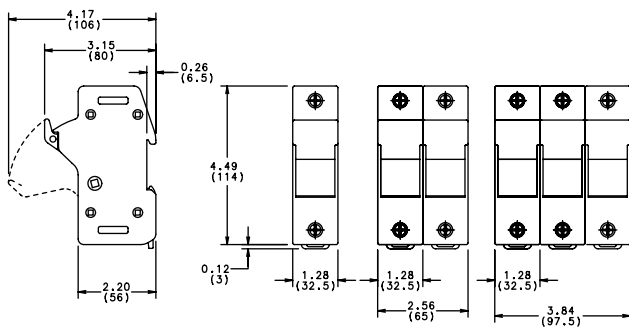

30 Amp

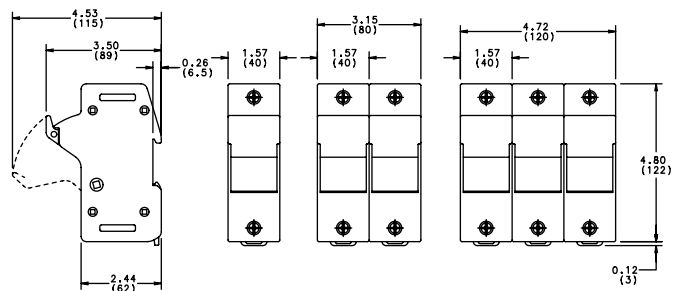

60 Amp

Specifications

Voltage Rating: 600 VAC
Interrupting Rating: 200 kA
Ampere Rating: 30 and 60 amperes
Terminal Type: Pressure plate
Suggested Torque: 30A – 35 inch-pounds
 60A – 45 inch-pounds
Wire Range: #2 – #14CU

Material: Thermo-plastic
Flammability Rating: 94V0
Approvals: UL Listed
 CSA Certified
 IEC Type IP20 Protection
 CE

Fuse Blocks, Holders and Accessories



POWR-Covers - Fuse Block Covers

Littelfuse fuse block covers protect personnel from accidentally contacting energized contacts. Covers are available for Class H, R, J, and CD type fuses up to 100 amps.

Features/benefits

- Meets “Dead Front” requirements and IEC Type IP20 Protection for most applications (see note)
- Easily gangable with optional “gang-slide” adapters
- Added safety to personnel
- Unique design allows Littelfuse Indicator® fuses to be seen through covers
- Ventilated to avoid fuse derating
- Covers are reusable
- Covers fit most competitor blocks
- LJ60100-3PC is a three pole clear plastic cover

For “Gang Slide” Adapters order:

- PCGS-2 for 2 poles
- PCGS-3 for 3 poles

NOTE: Contact Factory for specific applications.

Ordering information

Littelfuse Part Number	For Use With Fuse Block Number	Voltage	Amp	Fuse Class
LH25030-PC	LH25030/LR25030 series	250	30	H/R
LH25060-PC	LH25060/LR25060 series	250	60	H/R
LH25100-PC	LH25100/LR25100 series	250	100	H/R
LH60030-PC	LH60030/LR60030 series	600	30	H/R
LH60060-PC	LH60060/LR60060 series	600	60	H/R
LH60100-PC	LH60100/LR60100 series	600	100	H/R
LJ60030-PC	LJ60030 series only	600	30	J
LJ60060-PC	LJ60060 series only	600	60	J
LJ60100-PC*	LJ60100-1CR only	600	100	J
LJ60100-3PC	LJ60100-3CR only	600	100	J
L60060C-PC	L60060C series only	600	60	CD

**Note: For use with Class J fuses with 1" diameter, Littelfuse series JLS.*

Specifications

Voltage Rating: 600 Volts
Ampere Rating: Class H: 0-100 amps
 Class R: 0-100 amps
 Class J: 0-100 amps
 Class CD: 0-60 amps

Material: Thermoplastic
Approvals: UL Listed (File No: E184929)
 CSA Certified (File No: LR7316)

Fuse Blocks, Holders and Accessories



Fuse Pullers

Littelfuse ergonomically designed fuse pullers are the safe way of handling power fuses. They offer greater ease in removing fuses. This new molded design is superior to standard pullers because it offers a more comfortable and natural grip when pulling fuses, improving performance. Part No. LPFP

Part Number & Application

Midget Fuse Puller	MFP:	For 3/16" to 1/2" dia. fuses.
Pocket Fuse Puller	LPFP:	For 0 – 200A 250V, 0 – 100A 600V (9/16" – 119/32" dia. fuses)
Giant Fuse Puller	GFP:	61 – 600A 250V, 61 – 400A 600V (11/16" – 219/32" dia. fuses)
Tri-Puller	097023:	For ATO® and glass fuses.



POWR-JAW Clip Clamps

POWR-JAW clamps improve the contact between fuse and clip. The unnecessary heat from poor contact due to the loss of spring force in the clips can cause nuisance fuse opening and premature aging of surrounding components.

- High temperature phenolic resin knob designed for the most severe environments.
- 7 sizes to provide effective coverage.
- Simple design makes installation easy.

Part Number	Volts	Amperes
LCC 1	250	0-30
LCC 2	250	35-60
LCC 2	600	0-30
LCC 4	600	35-60
LCC 5	250/600	70-100
LCC 6	250/600	110-200
LCC 7	250/600	225-400
LCC 8	250/600	450-600

Note: POWR-JAW Clip Clamps are sold individually, not in pairs. A minimum of 1/8" of clearance between the fuse block barrier and fuse clip is required to install clip clamps.

Fuse Blocks, Holders and Accessories



571 Series Panel Mounted Fuseholders

Panel mount fuseholders are available for supplementary or Class CC branch circuit protection. Class CC fuses have a rejection feature on one end cap which mates with the rejection feature of Littelfuse Class CC fuse blocks and fuseholders to prevent the installation of fuses with lower voltage ratings or interrupting ratings. Watertight version must be front panel mounted.

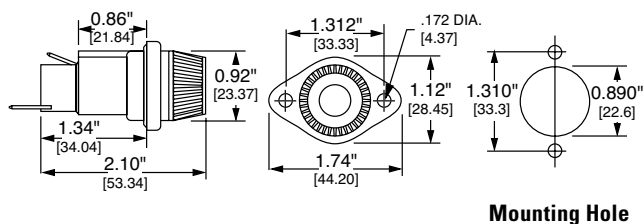

Ordering Information

Part Number		Bottom Terminal	Fuse Length Range*	For Use With
Standard	Watertight			
571 027	571 027P	Straight	1 ⁵ / ₁₆ " – 1 ³ / ₈ "	Midget Fuses
571 028	571 028P	Rt. Angle		
571 007	571 007P	Straight	1 ¹³ / ₃₂ " – 1 ¹ / ₂ "	Midget Fuses
571 008	571 008P	Rt. Angle		
571 OCC	571 OCCP	Straight	1 ¹ / ₂ "	Class CC Fuses
571 RCC	571 RCCP	Rt. Angle		

*Fuse diameter is 1³/₃₂".

Note: Contact the factory for versions with pre-assembled wire leads.

O-Rings: 901-184 (body)
901-260 (knob)

Specifications

Voltage Rating: 600 Volts
Ampere Rating: 30 amperes for Class CC and Midget fuses
Dielectric strength: 4000 Volts
Terminals: Tin-plated brass combination solder and quick-connect
Molded parts: Black thermoplastic
Approvals: UL Recognized (File No. E14721) — 571 series
UL Recognized for branch circuit protection — 571 OCC/RCC
CSA Certified (File No. LR7316)

Blocks and Holders

NEW



572 Series Panel Mounted Fuseholders

The 572 series panel mount fuse holders are designed to minimize installation time. The unique design incorporates a snap-mount feature that allows the holder to be installed without any tools or mounting hardware.

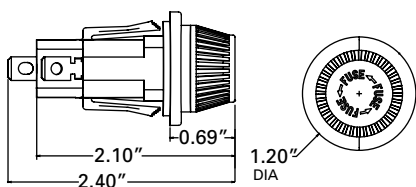

Ordering Information

Part Number		Bottom Terminal	Fuse Length Range*	For Use With
Standard	Watertight			
572 027	572 027P	Straight	1 ⁵ / ₁₆ " – 1 ³ / ₈ "	Midget Fuses
572 028	572 028P	Rt. Angle		
572 007	572 007P	Straight	1 ¹³ / ₃₂ " – 1 ¹ / ₂ "	Midget Fuses
572 008	572 008P	Rt. Angle		
572 OCC	572 OCCP	Straight	1 ¹ / ₂ "	Class CC Fuses
572 RCC	572 RCCP	Rt. Angle		

*Fuse diameter is 13/32"

Note: Contact the factory for versions with preassembled wire leads.

Specifications

Voltage Rating: 600 Volts
Ampere Rating: 30 Amperes for Class CC and Midget fuses
Dielectric Strength: 4000 Volts
Terminals: Tin-plated brass combination solder and quick-connect
Molder Parts: Black thermoplastic
Approvals: UL Recognized (File No. E14721) – 572 Series
UL Recognized for branch circuit protection – 571 OCC/RCC
CSA Certified (File No. LR7316)
Mounting: Designed to fit 14-18 gauge panels with Double "D" punch or 0.875" knock-out hole.

Fuse Blocks, Holders and Accessories



LFFB Series Limiter Fuse Block

The Littelfuse LFFB fuse block is designed to accept CNL and CNN style limiter fuses. Typical applications include: forklifts, golf carts, and other low voltage battery-operated equipment.

Specifications

- Voltage Rating:** 150 VAC/VDC
- Ampere Range:** 1 – 400 amperes
- Approvals:** Pending
- Construction:** Base — thermoplastic
Studs — steel zinc plated

Ordering Information

Example catalog number: LFFB001
Example system number: LFFB0001Z

Dimensions

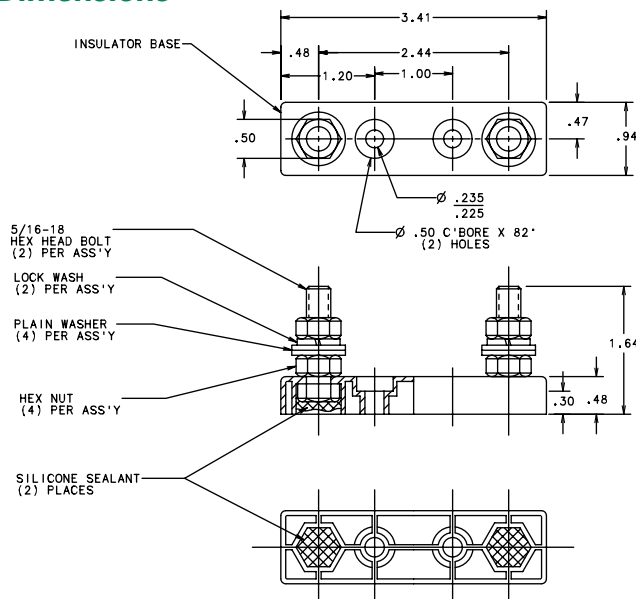

Recommended fuses

Littelfuse CNL/CNN limiter fuses and competitors' equivalents.



LHFH Inline Fuse Holder

The Littelfuse LHFH waterproof inline fuse holder is ideal for harsh environments. The easy to assemble one-piece molded thermoplastic body is a bright green color for high visibility. The LHFH holder accepts #12 to #18 gauge wire and features the voltage and ampere rating molded into the body, along with a wire strip gauge. Withstands solvents and vibration, for use with 1/4" x 1/4" fuses.

Installation Instructions

1. Thread wire through fuse holder body.
2. Strip wire insulation per strip gauge.
3. Crimp wire to fuse clip.*
4. Pull wire through and seat fuse clip in the holder body.
5. Insert desired fuse type and rating.
6. Snap holder body together.

*Recommended crimping tools: Thomas & Betts No. WT-111M

NOTE: Wire is not supplied with the holder.

Specifications

- Voltage Rating:** 32 Volts
- Ampere Rating:** 30 amperes

Semiconductor Fuse Blocks



Modular-designed Semiconductor fuse blocks are designed to accommodate a wide range of Semiconductor fuses, with a maximum diameter of 3". This modular design greatly reduces inventory requirements. They are sold in pairs and are constructed of molded phenolic, with plated steel studs.

LSCR001

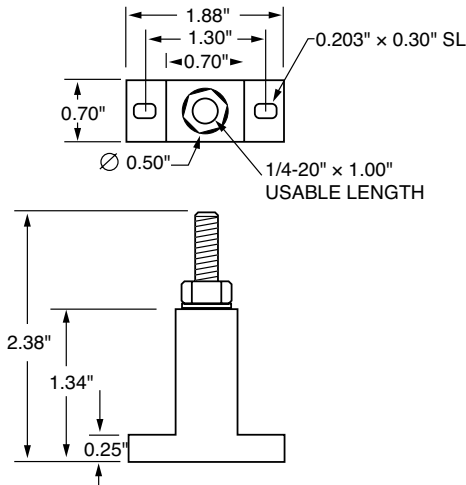

LSCR002

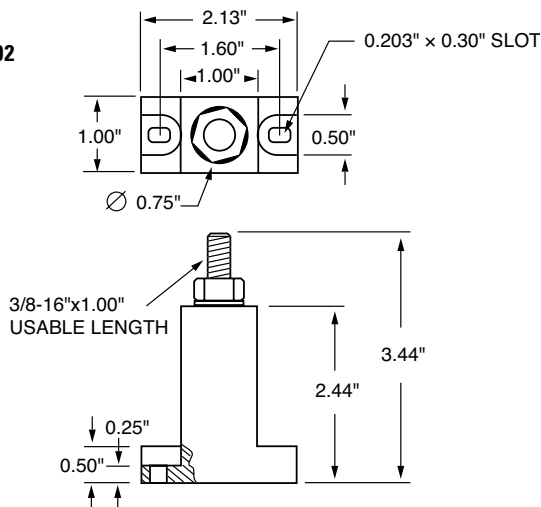

Recommended Fuses

Semiconductor fuses. See tables below.

LSCR001

Semiconductor fuse block selection guide

Fuse Series	Ampere Rating
L15S	70 – 400
L25S, LA30QS	35 – 60
L25S	70 – 200
L50S, LA50QS	35 – 60
L50S, LA50QS	70 – 100
L50S	125 – 200
L60S	35 – 60
L60S	70 – 100
L60S	125 – 200
L70S, LA70QS	35 – 60
L70S, LA70QS	70 – 100
KLC	1 – 30
KLC	35 – 60
LA100P	35 – 60

LSCR002

Semiconductor fuse block selection guide

Fuse Series	Ampere Rating
L15S, LA15QS	500 – 800
L25S, LA30QS	225 – 700
L25S, LA30QS	800
L50S, LA50QS	225 – 400
L50S, LA50QS	450 – 600
L50S, LA50QS	700 – 800
L60S	225 – 400
L60S	450 – 600
L60S	700 – 800
L70S, LA70QS	125 – 200
L70S, LA70QS	225 – 400
L70S, LA70QS	450 – 800
KLC	70 – 100
KLC	125 – 200
KLC	225 – 400
KLC	450 – 800
LA100P	70 – 800
JLLN	700 – 1200

Specifications

- Voltage rating:** LSCR001: Accepts fuses 1" diameter or less at 600V. Also accepts 1 1/16" diameter fuses at 700 – 1000V. LSCR002: Accepts fuses up to 3" diameter at 1000V.
- Ampere ratings:** LSCR001: 1 – 400 ampere capacity. LSCR002: 70 – 800 ampere capacity.
- Approvals:** UL Recognized (File No. E14721)
- Stud Size:** LSCR001: 1/4 - 20 thread (Torque: 65 In. LBS.) LSCR002: 3/8 - 16 thread (Torque: 192 In. LBS.)
- Base:** Molded phenolic. 150° C temperature rating.
- Terminal construction:** Plated steel. Supplied with nut and Belleville washer.

Semiconductor Fuse Blocks



Littelfuse 1LS series modular style semiconductor fuse blocks accommodate a wide range of semiconductor fuses. Blocks are provided in pairs with fuse mounting hardware.

- 2-piece modular design
- General purpose phenolic base
- Tin plated aluminum box lugs
- Dove-tailed interlocking feature (1LS101 only)
- Hex-head bolts and Belleville washers provided

Ordering Information

Littelfuse Catalog No.	Ampere Rating	Wire Range	Torque Rating	Approvals
1LS101	100A	#2/0 - 14 CU/AL	120 IN. LBS.	UL Recognized
1LS102	400A	250MCM - #6 CU/AL	275 IN. LBS.	UL Recognized
1LS103	400A	250MCM - #6 CU/AL	275 IN. LBS.	UL Recognized
1LS104	600A	500MCM - #6 CU/AL	375 IN. LBS.	UL Recognized
1LS108	400A	250MCM - #6 CU/AL	275 IN. LBS.	Self-Certified
1LS109	400A	250MCM - #6 CU/AL	275 IN. LBS.	Self-Certified
1LS110	400A	250MCM - #6 CU/AL	275 IN. LBS.	Self-Certified

Specifications

Voltage Rating: 600 Volts
Ampere Range: 1 – 600 amperes
Approvals: UL Recognized under the components program
Insulator Base: 150° C general purpose phenolic
 Box Lug Terminal: Tin plated aluminum

Dimensions

Dimensions for reference only.

1LS101

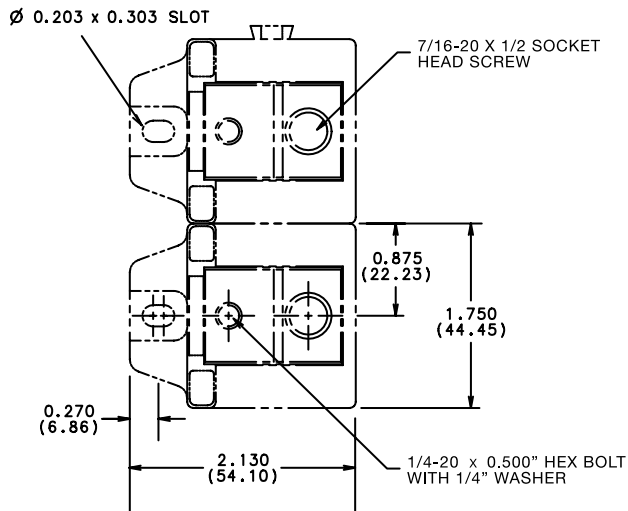

1LS102

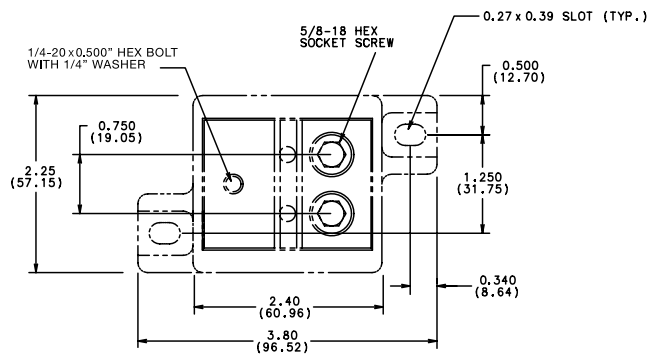

Semiconductor Fuse Blocks

Dimensions

1LS103

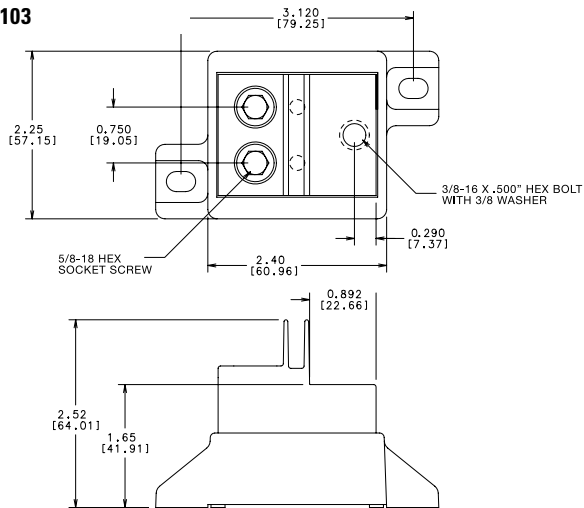

1LS104

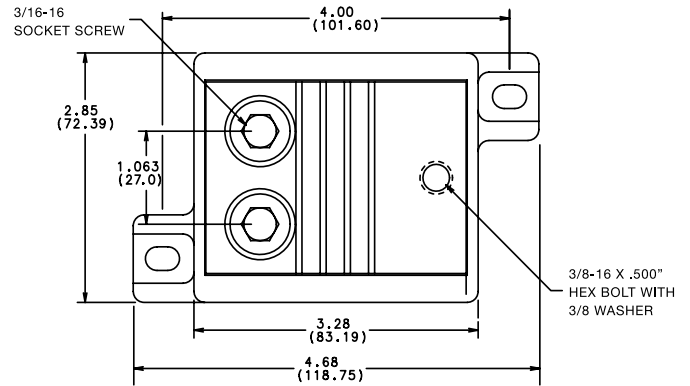

1LS108

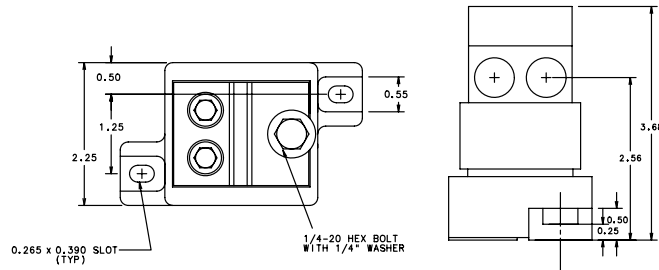

1LS109

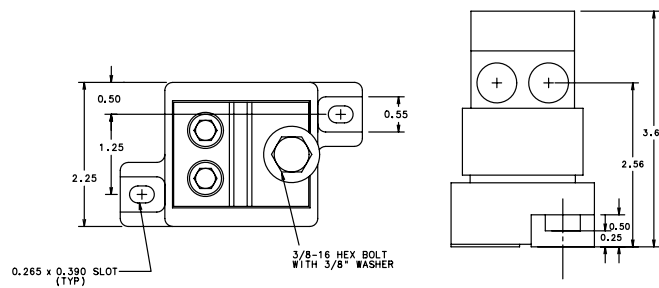

1LS110

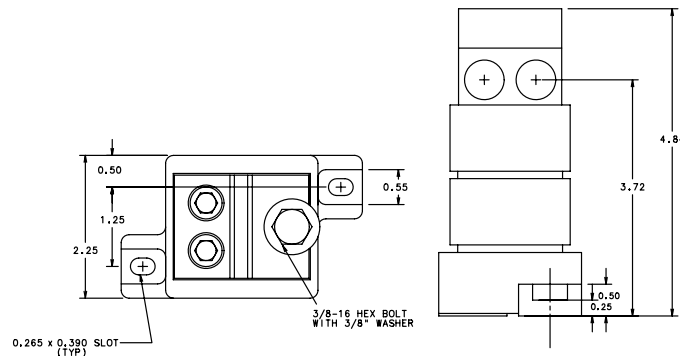

POWR-BLOKS™

Distribution/Splicer Blocks and Covers



POWR-BLOKS power distribution blocks offer a safe, convenient way of splicing cables, providing a fixed junction tap-off point or splitting primary power into secondary circuits. LX2xxx-DIN series offers integral DIN-Rail mount and an optional hinged safety cover.

Applications

Typical applications include heating, air conditioning and refrigeration systems, elevator systems, material handling equipment, control panels, motor controls, switchgear, and anywhere power needs to be distributed to more than one load.

Specifications

Voltage Rating: 600V
Amperage: Based on NEC Table 310.16, using 75°C copper wire
Material: Phenolic rated at 150°C and Thermoplastic rated at 125°C (LD1400 and LS1300 series only)

Connectors

Box lug connectors are designed for use with a single, solid or class B or C stranded conductor. Use of more than one conductor per connector opening or use of extra-flexible, fine stranded conductors, such as welding cable, voids the UL Listing, and may cause overheating. Manufacturers of cable terminations can furnish crimp-on sleeves for fine stranded conductors which permit these conductors to be used with box lugs.

Ampere Ratings

The ampere rating per pole for power distribution blocks is based on the line ampacity of 75°C insulated conductors per NEC Table 310.16. If 60°C insulated conductors are used, load must not exceed the ampacity of 60°C conductors. Use of conductors rated in excess of 75°C is permitted (for example 90°C), however, load must not exceed the ampacity of 75°C conductors.

Ordering Information

Distribution Block
Example Part No.

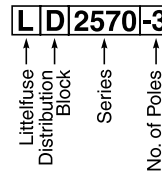

Splicer Block
Example Part No.

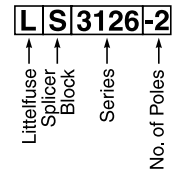

Note: Aluminum blocks can use copper or aluminum wire; copper blocks can only use copper wire.

Connector: Standard: Highly conductive aluminum, tin plated
 Copper: Highly conductive copper, tin plated
Flammability Rating: 94V-0
Approvals: UL Recognized (File No. E171395)
 CSA Certified (File No. LR700111)

POWR-BLOKS™

Distribution/Splicer Blocks and Covers



Littelfuse optional power distribution block covers provide protection against accidental shorting between poles caused by loose wires, tools, or other conductive material. They also protect personnel from accidentally contacting energized connectors. Clear plastic covers are available for most blocks. New Lx2xxx-xDIN series blocks offer a hinged cover. To order protective covers, match the number of poles for the block to the cover.

Distribution Block Covers

Hinged Plastic Covers

Littelfuse Part Number	For use with Distribution/Splicer Block No.	Number of Poles
LCH132-1	LD2xxx-1DIN / LS2xxx-1DIN	1
LCH132-2	LD2xxx-2DIN / LS2xxx-2DIN	2
LCH132-3	LD2xxx-3DIN / LS2xxx-3DIN	3

Note: Optional hinged covers snap on to blocks.



Clear Plastic Covers

Littelfuse Part Number	For use with Distribution/Splicer Block No.	Number of Poles
LPBC0-2	LD0xxx-2 / LS0xxx-2	2
LPBC0-3	LD0xxx-3 / LS0xxx-3	3
LPBC2-1	LD2xxx-1 / LS2xxx-1	1
LPBC2-2	LD2xxx-2 / LS2xxx-2	2
LPBC2-3	LD2xxx-3 / LS2xxx-3	3
LPBC3-1	LD3xxx-1 / LS3xxx-1	1
LPBC3-2	LD3xxx-2 / LS3xxx-2	2
LPBC3-3	LD3xxx-3 / LS3xxx-3	3
LPBC4-1	LD4xxx-1 / LS4xxx-1	1
LPBC4-2	LD4xxx-2 / LS4xxx-2	2
LPBC4-3	LD4xxx-3 / LS4xxx-3	3
LPBC5-1	LD5xxx-1 / LS5xxx-1	1
LPBC5-2	LD5xxx-2 / LS5xxx-2	2
LPBC5-3	LD5xxx-3 / LS5xxx-3	3

Note: For installation of optional clear plastic covers, use the screws provided with each cover.

POWR-BLOKS™

Distribution/Splicer Blocks and Covers

Distribution Block Selection Guide

Connector Configuration			Amp Rating per Pole	Number of Poles	Line		Load		Figure	Littelfuse Catalog Number
Mat'l	Line	Load			Wire Range	Openings per Pole	Wire Range	Openings per Pole		
AL			115	1	#2 - #14	1	#10 - #18	4	2	LD1400-1
			115	2	#2 - #14	1	#10 - #18	4	2	LD1400-2
			115	3	#2 - #14	1	#10 - #18	4	2	LD1400-3
			115	4	#2 - #14	1	#10 - #18	4	2	LD1400-4
AL			175	2	2/0 - #14	1	#4 - #14	6	1	LD0401-2
			175	3	2/0 - #14	1	#4 - #14	6	1	LD0401-3
AL			175	2	2/0 - #14	1	#4 - #14	4	1	LD0402-2
			175	3	2/0 - #14	1	#4 - #14	4	1	LD0402-3
AL			310	2	350mcm - #6	1	#4 - #14	6	1	LD0404-2
			310	3	350mcm - #6	1	#4 - #14	6	1	LD0404-3
AL			175	1	2/0 - #14	1	#4 - #14	4	3	LD2570-1
			175	2	2/0 - #14	1	#4 - #14	4	3	LD2570-2
			175	3	2/0 - #14	1	#4 - #14	4	3	LD2570-3
CU			175	1	2/0 - #14	1	#4 - #14	4	3	LD2970-1
			175	2	2/0 - #14	1	#4 - #14	4	3	LD2970-2
			175	3	2/0 - #14	1	#4 - #14	4	3	LD2970-3
AL			335	1	400mcm - #6	1	#2 - #14	4	5	LD3552-1
			335	2	400mcm - #6	1	#2 - #14	4	5	LD3552-2
			335	3	400mcm - #6	1	#2 - #14	4	5	LD3552-3
AL			335	1	400mcm - #6	1	#2 - #14	6	5	LD3553-1
			335	2	400mcm - #6	1	#2 - #14	6	5	LD3553-2
			335	3	400mcm - #6	1	#2 - #14	6	5	LD3553-3
AL			350	1	2/0 - #14	2	#4 - #14	6	5	LD3555-1
			350	2	2/0 - #14	2	#4 - #14	6	5	LD3555-2
			350	3	2/0 - #14	2	#4 - #14	6	5	LD3555-3
CU			380	1	500mcm - #4	1	#2 - #14	6	5	LD3953-1
			380	2	500mcm - #4	1	#2 - #14	6	5	LD3953-2
			380	3	500mcm - #4	1	#2 - #14	6	5	LD3953-3
CU			350	1	2/0 - #14	2	#4 - #14	6	5	LD3955-1
			350	2	2/0 - #14	2	#4 - #14	6	5	LD3955-2
			350	3	2/0 - #14	2	#4 - #14	6	5	LD3955-3
AL			380	1	500mcm - #4	1	#2 - #14	6	6	LD4551-1
			380	2	500mcm - #4	1	#2 - #14	6	6	LD4551-2
			380	3	500mcm - #4	1	#2 - #14	6	6	LD4551-3
AL			335	1	400mcm - #6	1	#2 - #14	8	6	LD4560-1
			335	2	400mcm - #6	1	#2 - #14	8	6	LD4560-2
			335	3	400mcm - #6	1	#2 - #14	8	6	LD4560-3
AL			380	1	500mcm - #4	1	#2 - #14	12	7	LD5552-1
			380	2	500mcm - #4	1	#2 - #14	12	7	LD5552-2
			380	3	500mcm - #4	1	#2 - #14	12	7	LD5552-3
AL			380	1	500mcm - #4	1	2/0 - #14	6	7	LD5579-1
			380	2	500mcm - #4	1	2/0 - #14	6	7	LD5579-2
			380	3	500mcm - #4	1	2/0 - #14	6	7	LD5579-3
AL			760	1	500mcm - #4	2	2/0 - #14	8	7	LD5586-1
			760	2	500mcm - #4	2	2/0 - #14	8	7	LD5586-2
			760	3	500mcm - #4	2	2/0 - #14	8	7	LD5586-3
AL			665	1	500mcm - #4	1	2/0 - #14	4	7	LD5587-1
				350mcm - #6	1					
			665	2	500mcm - #4	1	2/0 - #14	4	7	LD5587-2
				350mcm - #6	1					
665	3	500mcm - #4	1	2/0 - #14	4	7	LD5587-3			
		350mcm - #6	1							

POWR-BLOKS™

Distribution/Splicer Blocks and Covers

Distribution Block Selection Guide

Connector Configuration			Amp Rating per Pole	Number of Poles	Line		Load		Figure	Littelfuse Catalog Number
Mat'l	Line	Load			Wire Range	Openings per Pole	Wire Range	Openings per Pole		
AL			760	1	500mcm-#4	2	#4 - #14	12	7	LD5592-1
			760	2	500mcm-#4	2	#4 - #14	12	7	LD5592-2
			760	3	500mcm-#4	2	#4 - #14	12	7	LD5592-3
AL			380	1	500mcm-#4	1	#2 - #14	8	7	LD5594-1
			380	2	500mcm-#4	1	#2 - #14	8	7	LD5594-2
			380	3	500mcm-#4	1	#2 - #14	8	7	LD5594-3
CU			760	1	500mcm-#4	2	2/0 - #14	8	7	LD5986-1
			760	2	500mcm-#4	2	2/0 - #14	8	7	LD5986-2
			760	3	500mcm-#4	2	2/0 - #14	8	7	LD5986-3
CU			760	1	500mcm-#4	2	#2 - #14	12	7	LD5992-1
			760	2	500mcm-#4	2	#2 - #14	12	7	LD5992-2
			760	3	500mcm-#4	2	#2 - #14	12	7	LD5992-3
AL			175	1	2/0 - #14	1	#4 - #14	4	4	LD2570-1DIN
			175	2	2/0 - #14	1	#4 - #14	4	4	LD2570-2DIN
			175	3	2/0 - #14	1	#4 - #14	4	4	LD2570-3DIN
			175	Adder	2/0 - #14	1	#4 - #14	4	4	LD2570-ADIN
AL			175	1	2/0 - #14	1	#4 - #14	6	4	LD2580-1DIN
			175	2	2/0 - #14	1	#4 - #14	6	4	LD2580-2DIN
			175	3	2/0 - #14	1	#4 - #14	6	4	LD2580-3DIN
			175	Adder	2/0 - #14	1	#4 - #14	6	4	LD2580-ADIN
CU			175	1	2/0 - #14	1	#4 - #14	4	4	LD2970-1DIN
			175	2	2/0 - #14	1	#4 - #14	4	4	LD2970-2DIN
			175	3	2/0 - #14	1	#4 - #14	4	4	LD2970-3DIN
			175	Adder	2/0 - #14	1	#4 - #14	4	4	LD2970-ADIN

Blocks and Holders

POWR-BLOKS™

Distribution/Splicer Blocks and Covers

Splicer Block Selection Guide

Connector Configuration			Amp Rating per Pole	Number of Poles	Line		Load		Figure	Littelfuse Catalog Number
Mat'l	Line	Load			Wire Range	Openings per Pole	Wire Range	Openings per Pole		
AL			310	2	350mcm-#6	1	350mcm-#6	1	1	LS0303-2
			310	3	350mcm-#6	1	350mcm-#6	1	1	LS0303-3
AL			115	1	#2 - #14	1	#2 - #14	1	2	LS1300-1
			115	2	#2 - #14	1	#2 - #14	1	2	LS1300-2
			115	3	#2 - #14	1	#2 - #14	1	2	LS1300-3
			115	4	#2 - #14	1	#2 - #14	1	2	LS1300-4
CU			150	1	1/0 - #18	1	1/0 - #18	1	3	LS2121-1
			150	2	1/0 - #18	1	1/0 - #18	1	3	LS2121-2
			150	3	1/0 - #18	1	1/0 - #18	1	3	LS2121-3
AL			115	1	#2 - #14	1	#2 - #14	1	3	LS2552-1
			115	2	#2 - #14	1	#2 - #14	1	3	LS2552-2
			115	3	#2 - #14	1	#2 - #14	1	3	LS2552-3
AL			175	1	2/0 - #14	1	2/0 - #14	1	3	LS2572-1
			175	2	2/0 - #14	1	2/0 - #14	1	3	LS2572-2
			175	3	2/0 - #14	1	2/0 - #14	1	3	LS2572-3
AL			255	1	250mcm-#6	1	250mcm-#6	1	5	LS3123-1
			255	2	250mcm-#6	1	250mcm-#6	1	5	LS3123-2
			255	3	250mcm-#6	1	250mcm-#6	1	5	LS3123-3
CU			255	1	250mcm-#6	1	250mcm-#6	1	5	LS3124-1
			255	2	250mcm-#6	1	250mcm-#6	1	5	LS3124-2
			255	3	250mcm-#6	1	250mcm-#6	1	5	LS3124-3
AL			310	1	350mcm-#6	1	350mcm-#6	1	5	LS3126-1
			310	2	350mcm-#6	1	350mcm-#6	1	5	LS3126-2
			310	3	350mcm-#6	1	350mcm-#6	1	5	LS3126-3
AL			420	1	600mcm-#4	1	600mcm-#4	1	6	LS4557-1
			420	2	600mcm-#4	1	600mcm-#4	1	6	LS4557-2
			420	3	600mcm-#4	1	600mcm-#4	1	6	LS4557-3
AL			620	1	350mcm-#4	2	350mcm-#4	2	7	LS5129-1
			620	2	350mcm-#4	2	350mcm-#4	2	7	LS5129-2
			620	3	350mcm-#4	2	350mcm-#4	2	7	LS5129-3
AL			760	1	500mcm-#4	2	500mcm-#4	2	7	LS5301-1
			760	2	500mcm-#4	2	500mcm-#4	2	7	LS5301-2
			760	3	500mcm-#4	2	500mcm-#4	2	7	LS5301-3
AL			175	1	2/0 - #14	1	2/0 - #14	1	4	LS2572-1DIN
			175	2	2/0 - #14	1	2/0 - #14	1	4	LS2572-2DIN
			175	3	2/0 - #14	1	2/0 - #14	1	4	LS2572-3DIN
			175	A	2/0 - #14	1	2/0 - #14	1	4	LS2572-ADIN
CU			175	1	2/0 - #14	1	2/0 - #14	1	4	LS2972-1DIN
			175	2	2/0 - #14	1	2/0 - #14	1	4	LS2972-2DIN
			175	3	2/0 - #14	1	2/0 - #14	1	4	LS2972-3DIN
			175	A	2/0 - #14	1	2/0 - #14	1	4	LS2972-ADIN

POWR-BLOKS™

Distribution/Splicer Blocks and Covers

LX0XXX

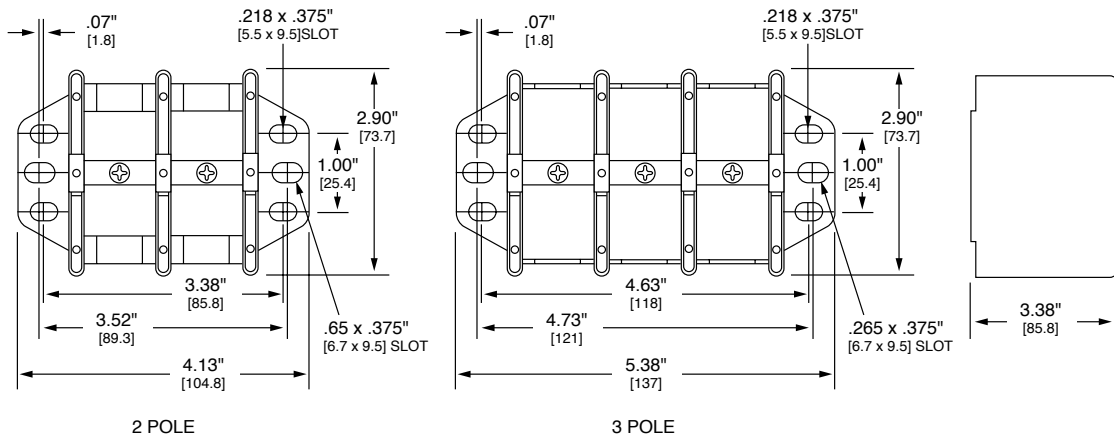

Figure 1

LX1XXX

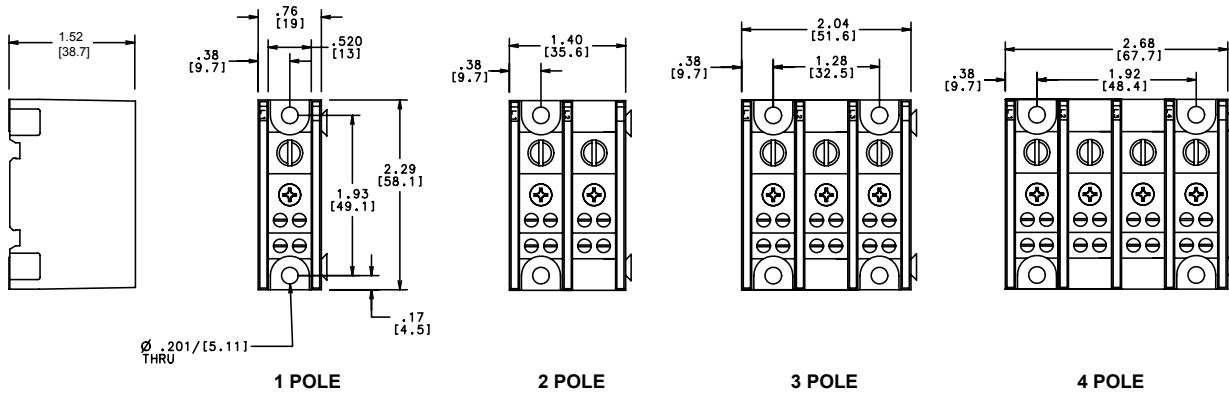

Figure 2

LX2XXX

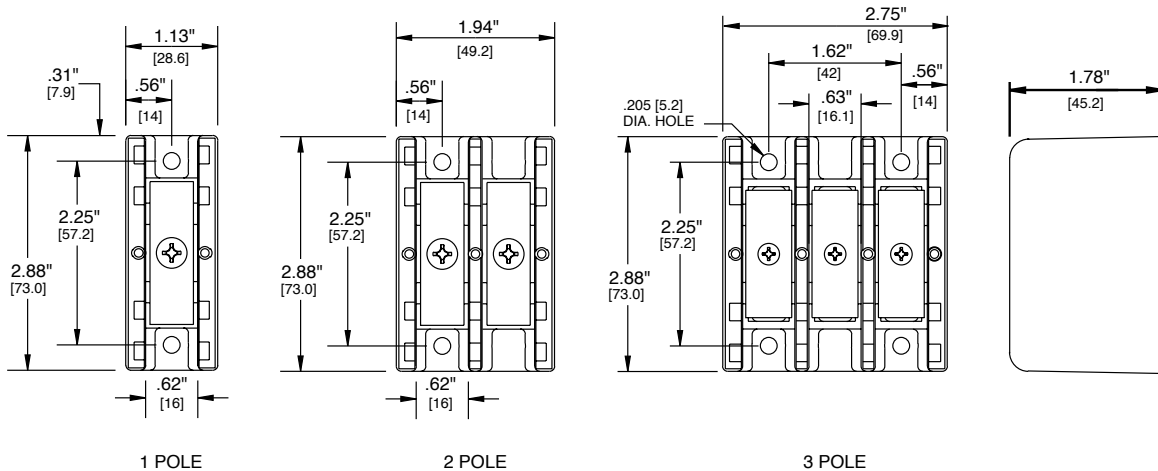

Figure 3

POWR-BLOKS™

Distribution/Splicer Blocks and Covers

LX2XXX-XDIN

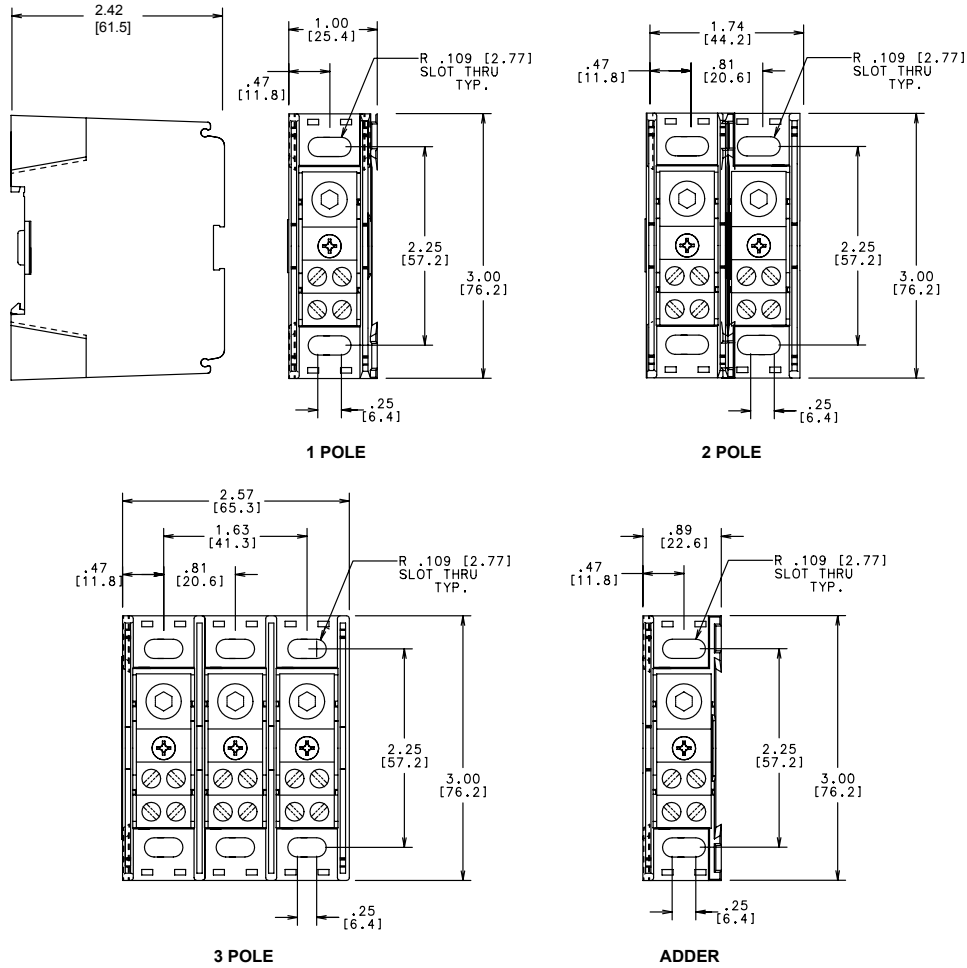

Figure 4

LX3XXX

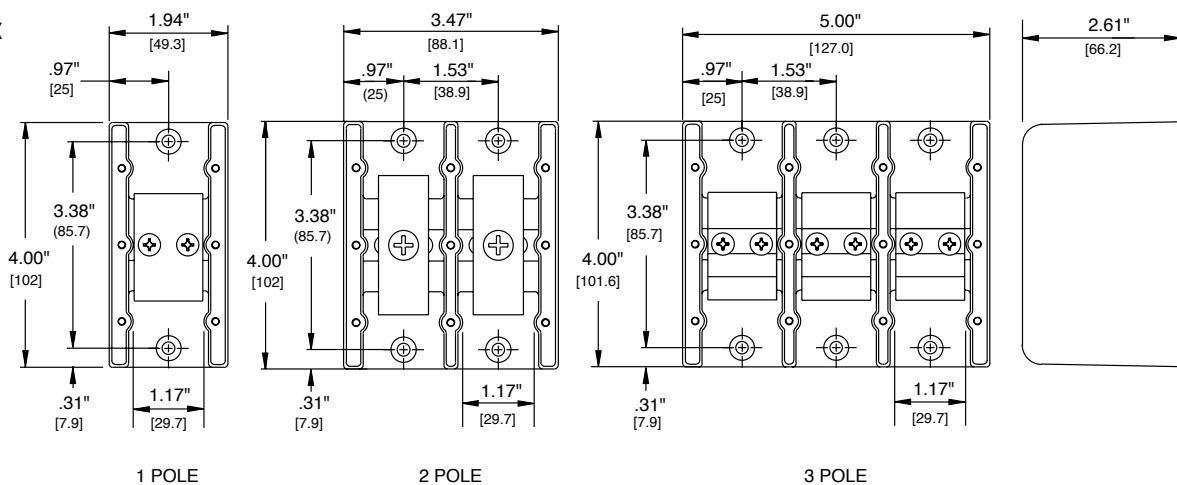

Figure 5

POWR-BLOKS™

Distribution/Splicer Blocks and Covers

LX4XXX

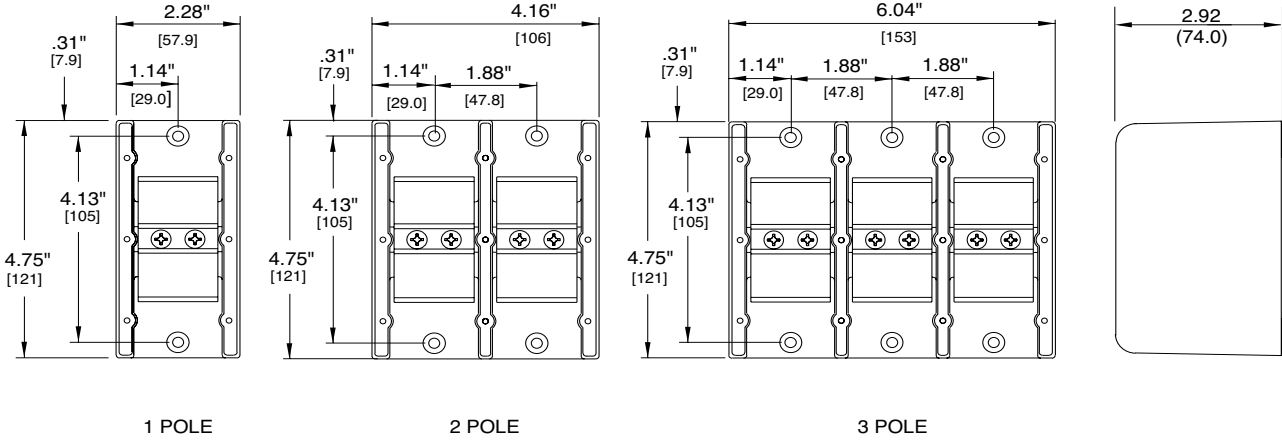

Figure 6

LX5XXX

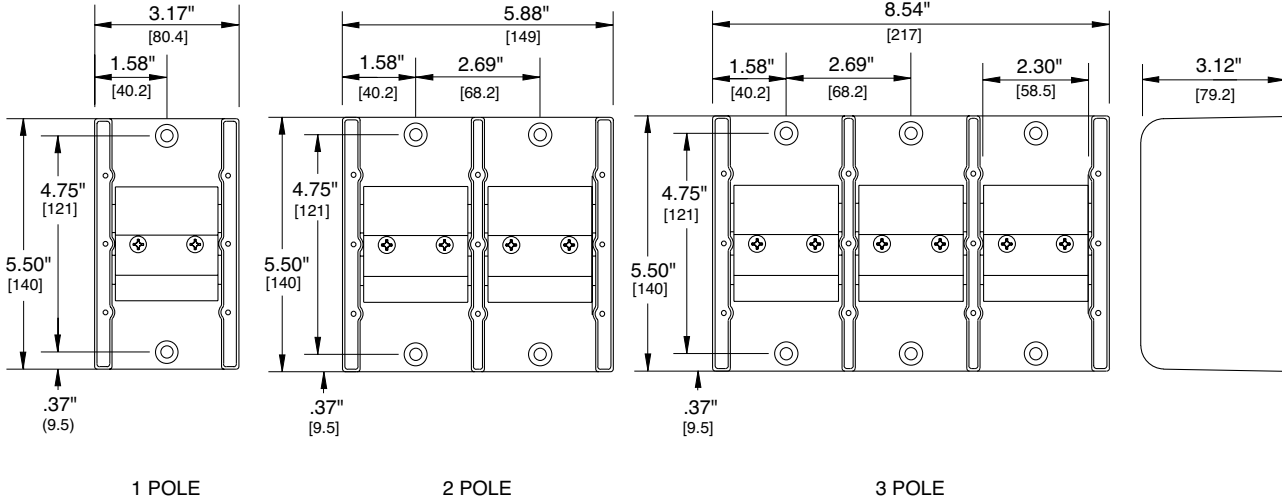
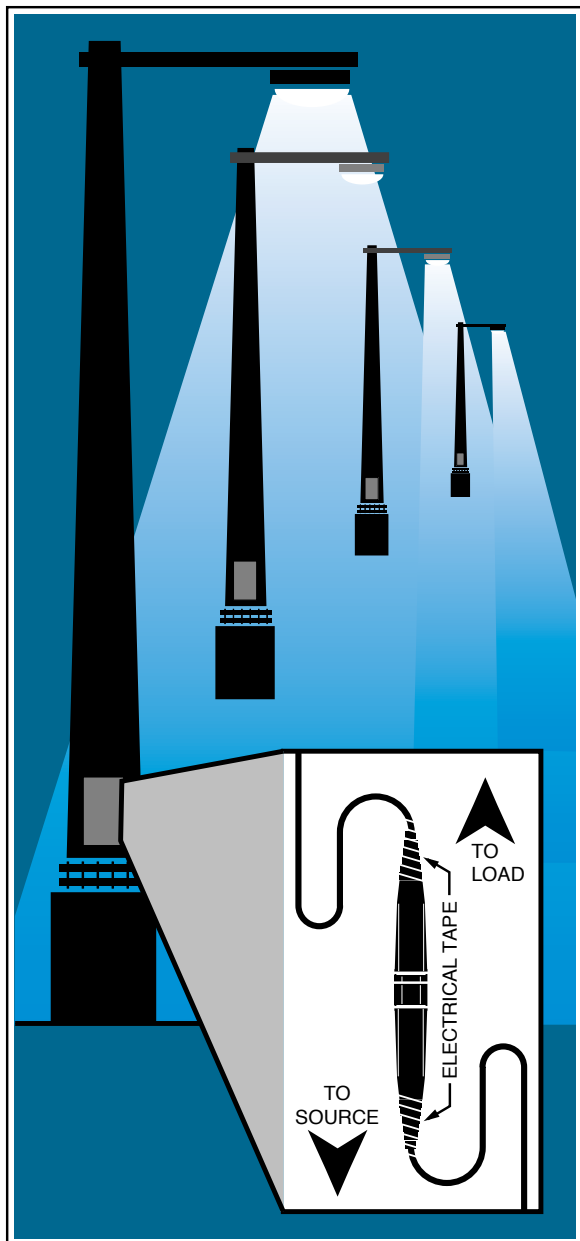

Figure 7

In-Line Watertight Fuseholders



Littelfuse 600 volt in-line watertight fuse holders are the ideal answer for all high humidity and corrosive environments where fuses are required. Available in both breakaway and non-breakaway, single and double pole versions, these fuseholders allow maximum flexibility for any application.

Applications

Street, alley, and parking lot lighting
 Security and perimeter lighting
 Traffic signals
 Outdoor illuminated signs
 Sports lighting
 Boat electrical circuits
 Tractors and yard equipment
 General outdoor circuit protection

Benefits

- Safety — Permits individual fixture or device to be disconnected from circuit for servicing. Eliminates possibility of shock.
- Individual fixture fusing — Prevents loss of one fixture through accident, vandalism, or end of life from darkening the entire circuit.
- Simplifies maintenance — Being able to immediately identify the one faulted fixture eliminates testing the entire circuit, speeds repair, and allows the individual unit to be serviced while the rest of the circuit is functioning.
- Reduces damage from fault — Can prevent faulted ballast or other failure from severely damaging fixture or device, reducing necessary repair or need of replacement.

Features

- Watertight — Internal O-ring provides watertight seal.
- Superior terminal seals — Ultrasonically-welded terminals provide maximum strength and eliminate leaking at terminals.
- Break resistant — Fiberglass reinforced polymer body resists damage from dropping or impact much better than phenolic look-alikes.
- Flexible terminations — Accommodates a wide range of stranded or solid copper or aluminum conductors. Terminations are available for one or two conductors, with either crimp or screw terminals.
- One-pole and two-pole models available to accommodate all system voltages up to 600V.

Specifications

Voltage rating: 600 Volts
Ampere rating: 30 amperes
 200,000 amperes rms symmetrical (with Class CC fuses)

Approvals:
LEB/LEX series: UL Recognized Miscellaneous Fuseholder per UL 512 (File No. E14721)
 CSA Certified per C22.2, No. 39 (File No. LR7316)

LEC/LEY series: UL Listed Class CC Branch Circuit Fuseholder per UL 512 (File No. E14721)
 CSA Certified per C22.2, No. 39 (File No. LR7316)

Mating fuses

LEB/LEX series: Accepts all 1 1/2" x 19/32" Midget and Class CC fuses
 Littelfuse types BLF, BLN, FLM, FLO, KLK, KLKD, KLKR, KLDR and CCMR.

LEC/LEY series: Accepts only Class CC fuses.
 Littelfuse types KLKR, KLDR and CCMR.

In-Line Watertight Fuseholders

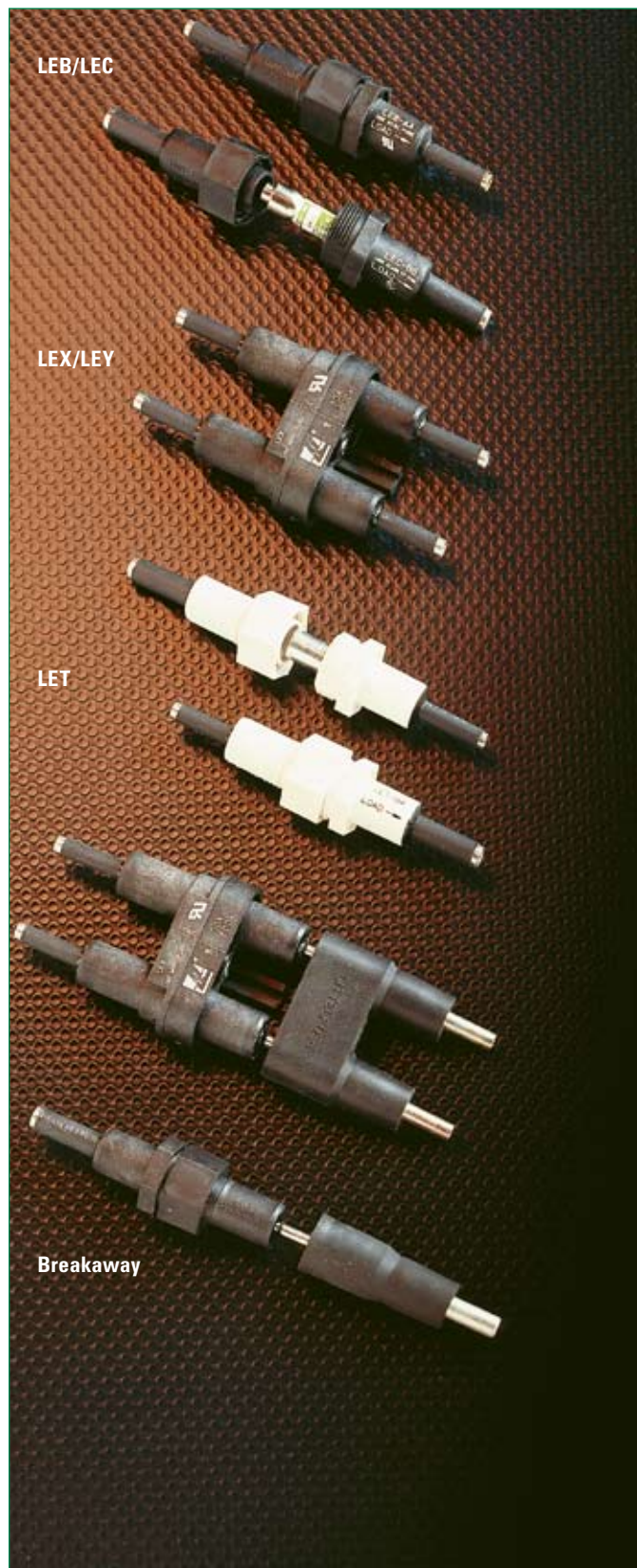

One-pole LEB and LEC Fuseholders

Basic single-pole LEB and LEC watertight fuseholders provide protection for a variety of circuits. LEB fuseholders accept all $1\frac{3}{32}$ " x $1\frac{1}{2}$ " midget fuses providing supplemental overcurrent protection. LEC fuseholders are UL Listed Class CC fuseholders which accept only Class CC fuses and meet National Electrical Code requirements for branch circuit protection. The most common use for either fuseholder is for protection of lighting circuits. However, consider them wherever there is a need for secure in-line protection, from boat circuits to electric wheelchairs. Great flexibility is achieved when the basic holders are combined with breakaway receptacles, Y-terminals and insulating boots.

Two-pole LEX and LEY Fuseholders

LEX and LEY fuseholders are intended for use on line-to-line circuits up to 600 volts and are ideal for line-to-line loads such as 240 or 480 volt ballasts. When the line and load sections of LEX and LEY fuseholders are separated, or when the fuseholder is removed from a two-pole breakaway receptacle, both lines are disconnected simultaneously. This prevents the possibility of shock from backfeeding through an exposed fuse, which could happen with single-pole fuseholders. The LEX holder is a two-pole version of the LEB and accepts midget fuses, providing supplementary overcurrent protection. The LEY holder is a two-pole version of the LEC, which accepts only Class CC fuses, and may be used to provide branch circuit protection. Both fuseholders may be equipped with Y-terminals, breakaway receptacles and insulating boots.

One-pole LET Solid Neutral Disconnects

The LET solid neutral disconnect is designed for use as a no-load non-fused disconnect. Similar in design to the LEB series fuseholders, the LET is easily identified by its all white body. Internally, it has a permanently installed solid tin-plated copper neutral slug which eliminates the possibility of placing a fuse in the neutral side of the circuit. Fusing the neutral side causes a safety hazard and also violates the National Electrical Code. The LET is available in both breakaway and non-breakaway configurations with a wide variety of terminations.

Breakaway Feature

Littelfuse LEB, LEC, and LET single-pole fuseholders and LEX and LEY two-pole fuseholders are available with an optional breakaway feature required to meet state and federal highway commission standards requiring fuseholders to readily disconnect from the line in case of a pole knockdown. The breakaway feature consists of a receptacle permanently attached to the power line and a fuseholder with matching terminals. When knockdown occurs, the parts separate readily. The breakaway receptacle terminal is deeply recessed so that energized parts are not exposed. The fuse remains safely enclosed inside the now de-energized watertight fuseholder. After the pole has been reinstalled, the fuseholder is easily plugged into the receptacle, immediately restoring service. The breakaway feature may also be used in marinas, travel trailer parks and other locations where circuits subjected to strain must be safely disconnected.

In-Line Watertight Fuseholders



A & B Crimp Terminal

C & D Crimp Terminal

J Terminal

Y Terminal

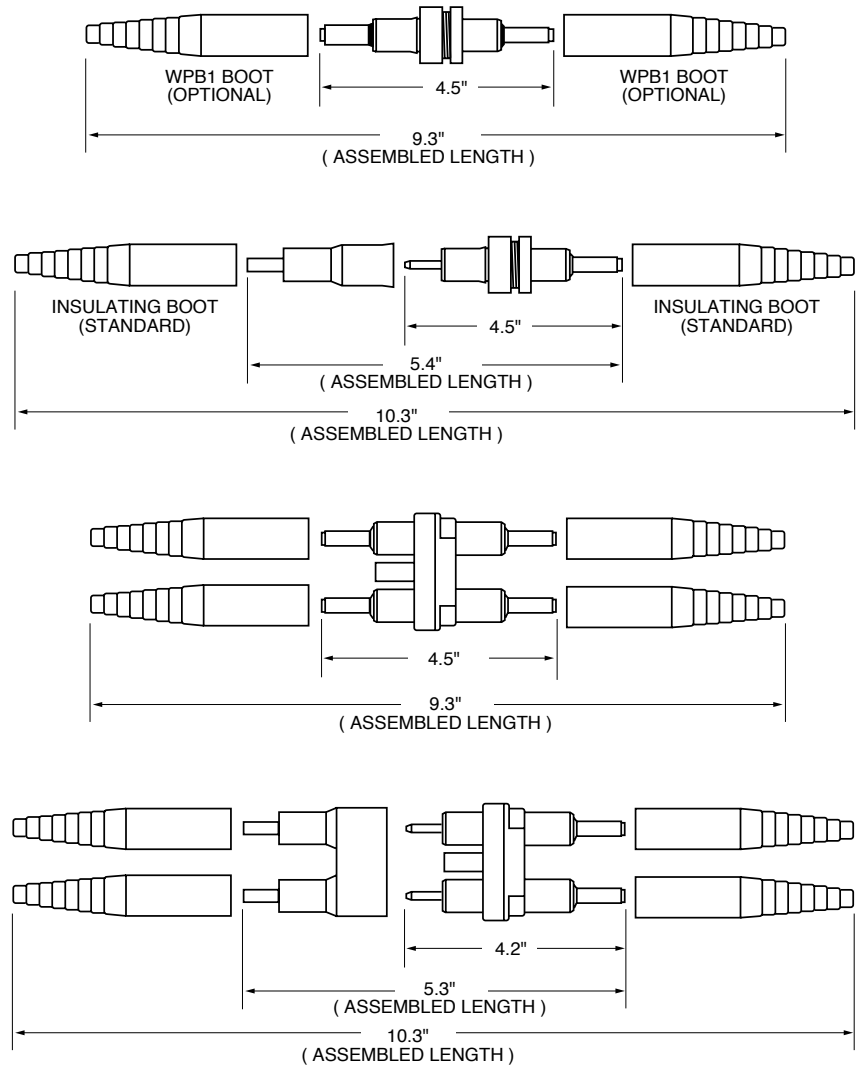

Insulating Boots

Molded from engineering grade thermoplastics, the WPB1 and WPB2 provide a high resistance to corrosive environments and deliver a watertight seal. Boots are supplied as standard with all breakaway versions. Weatherproof boots WPB1 and WPB2 can be purchased separately for all non-breakaway holders. Part number WPB1 contains one standard boot for use with A, B, C, D, or J termination. Part number WPB2 contains one Y-pole boot for use with the Y-pole termination. For watertight protection of non-breakaway Y-pole fuseholders, order one WPB1 and one WPB2 boot. For non-breakaway double-pole LEX and LEY holders with A, B, C, D, or J terminations, order four WPB1 boots. These insulating boots are designed to fit snugly onto wire insulation, but for best results with varying wire insulation sizes, a tape wrap should be completed.

Recommended Crimping Tools

The following crimping tools or equivalents may be used on either the non-breakaway or breakaway watertight in-line fuseholders.

Terminal Size	T&B Part No.	Burndy Part No.
A	WT161M	—
B	WT161M	MR4C
C	WT115A	Hypress Y34A
D	WT115A	Hypress Y34A

Ordering Information

To order Littelfuse in-line fuseholders and disconnects by part number, refer to the charts on the next page.



Fuseholder Type	Description
LEB	One-pole in-line fuseholder for Midget and Class CC fuses
LEC	One-pole in-line fuseholder for Class CC fuses
LET	One-pole in-line solid neutral disconnect
LEX	Two-pole in-line fuseholder for Midget and Class CC fuses
LEY	Two-pole in-line fuseholder for Class CC fuses

In-Line Watertight Fuseholders

Selection Guide For Single Pole LEB/LEC Fuseholders

Standard Part No.	Breakaway Part No.	Fuse Type	Load Terminal Selection					Line Terminal Selection				
			Terminal Type	Load Terminal Wire Size Range	No. of Wires per Terminal	Solid Wire	Stranded Wire	Terminal Type	Line Terminal Wire Size Range	No. of Wires per Terminal	Solid Wire	Stranded Wire
LEB-AA LEC-AA	LEB-AA-S LEC-AA-S	Midget Class CC	Copper Crimp	#12 to #8 #12	1 2	X X	X X	Copper Crimp	#12 to #8 #12	1 2	X X	X X
LEB-AB LEC-AB	LEB-AB-S LEC-AB-S	Midget Class CC	Copper Crimp	#12 to #8 #12	1 2	X X	X X	Copper Crimp	#10 #6 #4	2 1 1	X X —	X X X
LEB-AC LEC-AC	— —	Midget Class CC	Copper Crimp	#12 to #8 #12	1 2	X X	X X	Copper Crimp	#8 #4	2 1	X —	X X
LEB-AD LEC-AD	— —	Midget Class CC	Copper Crimp	#12 to #8 #12	1 2	X X	X X	Copper Crimp	#6 #2	2 1	X —	X X
LEB-AJ LEC-AJ	LEB-AJ-S LEC-AJ-S	Midget Class CC	Copper Crimp	#12 to #8 #12	1 2	X X	X X	Copper Set-Screw	#12 to #8 #10 to #2	1 1	X —	— X
LEB-AYC LEC-AYC	LEB-AYC-S LEC-AYC-S	Midget Class CC	Copper Crimp	#12 to #8 #12	1 2	X X	X X	"Y" Type Copper Set-Screw	#12 to #8 #10 to #2	1 1	X —	— X
LEB-BA LEC-BA	LEB-BA-S LEC-BA-S	Midget Class CC	Copper Crimp	#10 #6 #4	2 1 1	X X —	X X X	Copper Crimp	#12 to #8 #12	1 2	X X	X X
LEB-BB LEC-BB	LEB-BB-S LEC-BB-S	Midget Class CC	Copper Crimp	#10 #6 #4	2 1 1	X X —	X X X	Copper Crimp	#10 #6 #4	2 1 1	X X —	X X X
LEB-BC LEC-BC	— —	Midget Class CC	Copper Crimp	#10 #6 #4	2 1 1	X X —	X X X	Copper Crimp	#8 #4	2 1	X —	X X
LEB-BD LEC-BD	— —	Midget Class CC	Copper Crimp	#10 #6 #4	2 1 1	X X —	X X X	Copper Crimp	#6 #2	2 1	X —	X X
LEB-BJ LEC-BJ	LEB-BJ-S LEC-BJ-S	Midget Class CC	Copper Crimp	#10 #6 #4	2 1 1	X X —	X X X	Copper Set-Screw	#12 to #8 #10 to #2	1 1	X —	— X
LEB-BYC LEC-BYC	LEB-BYC-S LEC-BYC-S	Midget Class CC	Copper Crimp	#10 #6 #4	2 1 1	X X —	X X X	"Y" Type Copper Set-Screw	#12 to #8 #10 to #2	1 1	X —	— X
LEB-CA LEC-CA	— —	Midget Class CC	Copper Crimp	#8 #4	2 1	X —	X X	Copper Crimp	#12 to #8 #12	1 2	X X	X X
LEB-CB LEC-CB	— —	Midget Class CC	Copper Crimp	#8 #4	2 1	X —	X X	Copper Crimp	#10 #6 #4	2 1 1	X X —	X X X
LEB-CC LEC-CC	— —	Midget Class CC	Copper Crimp	#8 #4	2 1	X —	X X	Copper Crimp	#8 #4	2 1	X —	X X
LEB-CD LEC-CD	— —	Midget Class CC	Copper Crimp	#8 #4	2 1	X —	X X	Copper Crimp	#6 #2	2 1	X —	X X
LEB-CJ LEC-CJ	— —	Midget Class CC	Copper Crimp	#8 #4	2 1	X —	X X	Copper Set-Screw	#12 to #8 #10 to #2	1 1	X —	X X
LEB-CYC LEC-CYC	— —	Midget Class CC	Copper Crimp	#8 #4	2 1	X —	X X	"Y" Type Copper Set-Screw	#12 to #8 #10 to #2	1 1	X —	— X
LEB-DA LEC-DA	— —	Midget Class CC	Copper Crimp	#6 #2	2 1	X —	X X	Copper Crimp	#12 to #8 #12	1 2	X X	— X
LEB-DB LEC-DB	— —	Midget Class CC	Copper Crimp	#6 #2	2 1	X —	X X	Copper Crimp	#10 #6 #4	2 1 1	X X —	X X X
LEB-DC LEC-DC	— —	Midget Class CC	Copper Crimp	#6 #2	2 1	X —	X X	Copper Crimp	#8 #4	2 1	X —	X X
LEB-DD LEC-DD	— —	Midget Class CC	Copper Crimp	#6 #2	2 1	X —	X X	Copper Crimp	#6 #2	2 1	X —	X X
LEB-DJ LEC-DJ	— —	Midget Class CC	Copper Crimp	#6 #2	2 1	X —	X X	Copper Set-Screw	#12 to #8 #10 to #2	2 1	X —	X X
LEB-DYC LEC-DYC	— —	Midget Class CC	Copper Crimp	#6 #2	2 1	X —	X X	"Y" Type Copper Set-Screw	#12 to #8 #10 to #2	1 1	X —	— X
LEB-JJ LEC-JJ	LEB-JJ-S LEC-JJ-S	Midget Class CC	Copper Set Screw	#12 to #8 #10 to #2	1 1	X —	— X	Copper Set-Screw	#12 to #8 #10 to #2	1 1	X —	— X
LEB-JYC LEC-JYC	LEB-JYC-S LEC-JYC-S	Midget Class CC	Copper Set Screw	#12 to #8 #10 to #2	1 1	X —	— X	"Y" Type Copper Set-Screw	#12 to #8 #10 to #2	1 1	X —	— X

Blocks and Holders

In-Line Watertight Fuseholders

Selection Guide For Double Pole LEX/LEY Fuseholders

Standard Part No.	Breakaway Part No.	Fuse Type	Load Terminal Selection					Line Terminal Selection				
			Terminal Type	Load Terminal Wire Size Range	No. of Wires per Terminal	Solid Wire	Stranded Wire	Terminal Type	Line Terminal Wire Size Range	No. of Wires per Terminal	Solid Wire	Stranded Wire
LEX-AA LEY-AA	LEX-AA-S LEY-AA-S	Midget Class CC	Copper Crimp	#12 to #8 #12	1 2	X X	X X	Copper Crimp	#12 to #8 #12	1 2	X X	X X
LEX-AB LEY-AB	LEX-AB-S LEY-AB-S	Midget Class CC	Copper Crimp	#12 to #8 #12	1 2	X X	X X	Copper Crimp	#10 #6 #4	2 1 1	X X —	X X X
LEX-AC LEY-AC	— —	Midget Class CC	Copper Crimp	#12 to #8 #12	1 2	X X	X X	Copper Crimp	#8 #4	2 1	X —	X X
LEX-AD LEY-AD	— —	Midget Class CC	Copper Crimp	#12 to #8 #12	1 2	X X	X X	Copper Crimp	#6 #2	2 1	X —	X X
LEX-AYC LEY-AYC	LEX-AYC-S LEY-AYC-S	Midget Class CC	Copper Crimp	#12 to #8 #12	1 2	X X	X X	"Y" Type Copper Set-Screw	#12 to #8 #10 to #2	1 1	X —	— X
LEX-BA LEY-BA	LEX-BA-S LEY-BA-S	Midget Class CC	Copper Crimp	#10 #6 #4	2 1 1	X X —	X X X	Copper Crimp	#12 to #8 #12	1 2	X X	X X
LEX-BB LEY-BB	LEX-BB-S LEY-BB-S	Midget Class CC	Copper Crimp	#10 #6 #4	2 1 1	X X —	X X X	Copper Crimp	#10 #6 #4	2 1 1	X X —	X X X
LEX-BC LEY-BC	— —	Midget Class CC	Copper Crimp	#10 #6 #4	2 1 1	X X —	X X X	Copper Crimp	#8 #4	2 1	X —	X X
LEX-BD LEY-BD	— —	Midget Class CC	Copper Crimp	#10 #6 #4	2 1 1	X X —	X X X	Copper Crimp	#6 #2	2 1	X —	X X
LEX-BYC LEY-BYC	LEX-BYC-S LEY-BYC-S	Midget Class CC	Copper Crimp	#10 #6 #4	2 1 1	X X —	X X X	"Y" Type Copper Set-Screw	#12 to #8 #10 to #2	1 1	X —	— X
LEX-CA LEY-CA	— —	Midget Class CC	Copper Crimp	#8 #4	2 1	X —	X X	Copper Crimp	#12 to #8 #12	1 2	X X	X X
LEX-CB LEY-CB	— —	Midget Class CC	Copper Crimp	#8 #4	2 1	X —	X X	Copper Crimp	#10 #6 #4	2 1 1	X X —	X X X
LEX-CC LEY-CC	— —	Midget Class CC	Copper Crimp	#8 #4	2 1	X —	X X	Copper Crimp	#8 #4	2 1	X —	X X
LEX-CD LEY-CD	— —	Midget Class CC	Copper Crimp	#8 #4	2 1	X —	X X	Copper Crimp	#6 #2	2 1	X —	X X
LEX-CJ LEY-CJ	— —	Midget Class CC	Copper Crimp	#8 #4	2 1	X —	X X	Copper Set-Screw	#12 to #8 #10 to #2	1 1	X —	— X
LEX-CYC LEY-CYC	— —	Midget Class CC	Copper Crimp	#8 #4	2 1	X —	X X	"Y" Type Copper Set-Screw	#12 to #8 #10 to #2	1 1	X —	— X
LEX-DA LEY-DA	— —	Midget Class CC	Copper Crimp	#6 #2	2 1	X —	X X	Copper Crimp	#12 to #8 #12	1 2	X X	X X
LEX-DB LEY-DB	— —	Midget Class CC	Copper Crimp	#6 #2	2 1	X —	X X	Copper Crimp	#10 #6 #4	2 1 1	X X —	X X X
LEX-DC LEY-DC	— —	Midget Class CC	Copper Crimp	#6 #2	2 1	X —	X X	Copper Crimp	#8 #4	2 1	X —	X X
LEX-DD LEY-DD	— —	Midget Class CC	Copper Crimp	#6 #2	2 1	X —	X X	Copper Crimp	#6 #2	2 1	X —	X X
LEX-DJ LEY-DJ	— —	Midget Class CC	Copper Crimp	#6 #2	2 1	X —	X X	Copper Set-Screw	#12 to #8 #10 to #2	1 1	X —	— X
LEX-DYC LEYDYC	— —	Midget Class CC	Copper Crimp	#6 #2	2 1	X —	X X	"Y" Type Copper Set-Screw	#12 to #8 #10 to #2	1 1	X —	— X
LEX-JJ LEY-JJ	LEX-JJ-S LEY-JJ-S	Midget Class CC	Copper Set-Screw	#12 to #8 #10 to #2	1 1	X —	— X	Copper Set-Screw	#12 to #8	1 1	X —	— X

In-Line Watertight Fuseholders

Selection Guide For Solid Neutral LET Fuseholders

Standard Part No.	Breakaway Part No.	Fuse Type	Load Terminal Selection					Line Terminal Selection				
			Terminal Type	Load Terminal Wire Size Range	No. of Wires per Terminal	Solid Wire	Stranded Wire	Terminal Type	Line Terminal Wire Size Range	No. of Wires per Terminal	Solid Wire	Stranded Wire
LET-AA	LET-AA-S	Solid Neutral	Copper Crimp	#12 to #8	1	X	X	Copper Crimp	#12 to #8	1	X	X
				#12	2	X	X		#12	2	X	X
LET-AB	LET-AB-S	Solid Neutral	Copper Crimp	#12 to #8	1	X	X	Copper Crimp	#10	2	X	X
				#12	2	X	X		#6	1	X	X
									#4	1	—	X
LET-AYC	LET-AYC-S	Solid Neutral	Copper Crimp	#12 to #8	1	X	X	"Y" Type Copper Set-Screw	#12 to #8	1	X	—
				#12	2	X	X		#10 to #2	1	—	X
LET-BA	LET-BA-S	Solid Neutral	Copper Crimp	#10	2	X	X	Copper Crimp	#12 to #8	1	X	X
				#6	1	X	X		#12	2	X	X
				#4	1	—	X					
LET-BB	LET-BB-S	Solid Neutral	Copper Crimp	#10	2	X	X	Copper Crimp	#10	2	X	X
				#6	1	X	X		#6	1	X	X
				#4	1	—	X		#4	1	—	X
LET-BYC	LET-BYC-S	Solid Neutral	Copper Crimp	#10	2	X	X	"Y" Type Copper Set-Screw	#12 to #8	1	X	—
				#6	1	X	X		#10 to #2	1	—	X
				#4	1	—	X					
LET-JJ	LET-JJ-S	Solid Neutral	Copper Set-Screw	#12 to #8	1	X	—	Copper Set-Screw	#12 to #8	1	X	—
				#10 to #2	1	—	X		#10 to #2	1	—	X
LET-JYC	LET-JYC-S	Solid Neutral	Copper Set-Screw	#12 to #8	1	X	—	"Y" Type Copper Set-Screw	#12 to #8	1	X	—
				#10 to #2	1	—	X		#10 to #2	1	—	X

Terminal Selection Guide

Terminal Designation	Terminal Description	Number of Wires per Terminal	Wire Range	Wire Type
A	Copper Crimp	1	#12-#8	Solid/Stranded
		2	#12	Solid/Stranded
B	Copper Crimp	2	#10	Solid/Stranded
		1	#6	Solid/Stranded
		1	#4	Stranded
C	Copper Crimp	2	#8	Solid/Stranded
		1	#4	Stranded
D	Copper Crimp	2	#6	Solid/Stranded
		1	#2	Stranded
J	Copper Set Screw	1	#12-#8	Solid
		2	#10-#2	Stranded
Y (2 terminals)	"Y" Style Copper Set Screw	1	#12-#8	Solid
		1	#10-#2	Stranded

Компания «Life Electronics» занимается поставками электронных компонентов импортного и отечественного производства от производителей и со складов крупных дистрибьюторов Европы, Америки и Азии.

С конца 2013 года компания активно расширяет линейку поставок компонентов по направлению коаксиальный кабель, кварцевые генераторы и конденсаторы (керамические, пленочные, электролитические), за счёт заключения дистрибьюторских договоров

Мы предлагаем:

- Конкурентоспособные цены и скидки постоянным клиентам.
- Специальные условия для постоянных клиентов.
- Подбор аналогов.
- Поставку компонентов в любых объемах, удовлетворяющих вашим потребностям.
- Приемлемые сроки поставки, возможна ускоренная поставка.
- Доставку товара в любую точку России и стран СНГ.
- Комплексную поставку.
- Работу по проектам и поставку образцов.
- Формирование склада под заказчика.
- Сертификаты соответствия на поставляемую продукцию (по желанию клиента).
- Тестирование поставляемой продукции.
- Поставку компонентов, требующих военную и космическую приемку.
- Входной контроль качества.
- Наличие сертификата ISO.

В составе нашей компании организован Конструкторский отдел, призванный помогать разработчикам, и инженерам.

Конструкторский отдел помогает осуществить:

- Регистрацию проекта у производителя компонентов.
- Техническую поддержку проекта.
- Защиту от снятия компонента с производства.
- Оценку стоимости проекта по компонентам.
- Изготовление тестовой платы монтаж и пусконаладочные работы.



Тел: +7 (812) 336 43 04 (многоканальный)

Email: org@lifeelectronics.ru