

## SE-701 MANUAL

### GROUND-FAULT MONITOR

Revision 10-C-072414

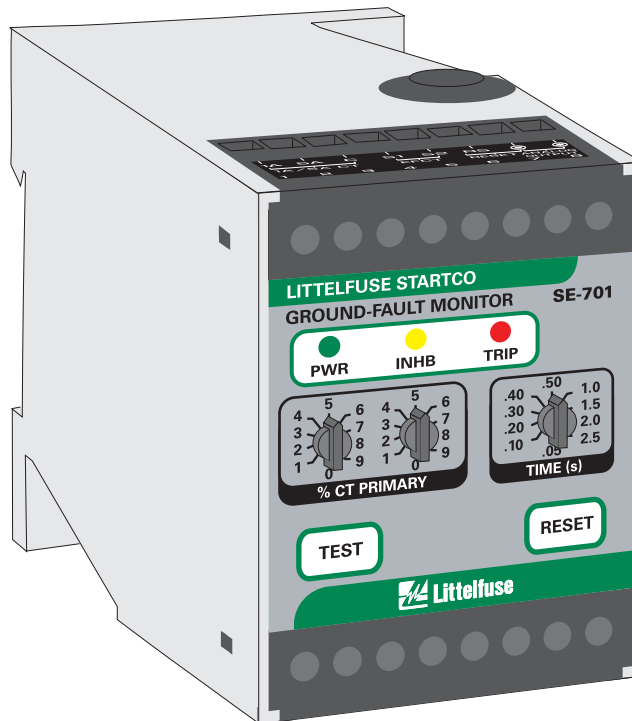

Copyright © 2014 by Littelfuse Startco

All rights reserved.

This page intentionally left blank.

## TABLE OF CONTENTS

SECTION	PAGE
<b>1 Introduction</b> .....	1
1.1 General .....	1
1.2 Current-Sensor Selection .....	1
<b>2 Operation</b> .....	1
2.1 Configuration-Switch Settings .....	1
2.1.1 Relay Operating Mode .....	1
2.1.2 Trip Inhibit .....	1
2.1.3 CT Verification .....	1
2.1.4 Filter Selection .....	1
2.1.5 Reset Mode .....	1
2.2 Front-Panel Controls .....	2
2.2.1 Ground-Fault Trip Level .....	2
2.2.2 Ground-Fault Trip Time .....	2
2.2.3 Reset .....	2
2.2.4 Test .....	2
2.3 Front-Panel Indication .....	2
2.3.1 Power .....	2
2.3.2 Trip .....	2
2.3.3 Trip Inhibit .....	2
2.4 Analog Output .....	2
2.5 Self Diagnostics .....	2
<b>3 Installation</b> .....	3
<b>4 SE-701 Compatibility</b> .....	6
<b>5 Technical Specifications</b> .....	14
<b>6 Ordering Information</b> .....	16
<b>7 Warranty</b> .....	17
<b>8 Ground-Fault Performance Test</b> .....	18
<b>Appendix A SE-701 Revision History</b> .....	20

## LIST OF FIGURES

FIGURE	PAGE
1 SE-701 Outline and Mounting Details .....	4
2 Typical Connection Diagrams .....	5
3 Typical Three-Phase-Starter Connection .....	5
4 EFCT-1 Outline and Mounting Details .....	7
5 EFCT-2 Outline and Mounting Details .....	8
6 EFCT-26 and SE-CS30-26 Outline and Mounting Details .....	9
7 SE-CS30-70 Current Sensor .....	10
8 SE-CS30-4, -5, and -8 Current Sensors .....	11
9 PMA-55 Panel-Mount Adapter .....	12
10 PMA-60 Panel-Mount Adapter .....	13
11 PGA-0500 Analog Percent Current Meter .....	14
12 Ground-Fault-Test Circuits .....	18

## LIST OF TABLES

TABLE	PAGE
1 Trip-Features Comparison .....	6
2 Ground-Fault-Test Record .....	19

## DISCLAIMER

Specifications are subject to change without notice. Littelfuse Startco is not liable for contingent or consequential damages, or for expenses sustained as a result of incorrect application, incorrect adjustment, or a malfunction.

This page intentionally left blank.

## 1. INTRODUCTION

### 1.1 GENERAL

The SE-701 is a microprocessor-based ground-fault monitor for resistance-grounded and solidly grounded systems. It is uniquely suited for use on systems with significant harmonic content. Its output relay can operate in the fail-safe or non-fail-safe mode for undervoltage or shunt-trip applications. The SE-701 has one output relay with isolated normally open and normally closed contacts for use in independent control circuits. Additional features include LED trip, power, and inhibit indication, autoreset or latching trips with front-panel and remote reset, trip memory, test button, self diagnostics, 0- to 5-V analog output, inputs for ground-fault current sensors, CT verification for EFCT-series current sensors, digital selector switches, switch-selectable algorithms for fixed-frequency or variable-frequency applications, and an inhibit that can be enabled to prevent the output relay from operating during a high-current ground fault.

Ground-fault current is sensed by a current transformer. Core-balance zero sequence current sensors (CT's) are most commonly used. Bus bar or toroid style CT's can also be used on the neutral to ground connection. See Fig. 2 in Technical Note CT-08 available at [www.littelfuse.com](http://www.littelfuse.com). The trip level of the ground-fault circuit is switch selectable in 1% increments from 1 to 99% of the CT rating.

### 1.2 CURRENT-SENSOR SELECTION

An SE-701 has inputs for 1-, 5-A, and 50-mA-secondary CT's. Choose a CT that provides the required ground-fault-trip range.

For ground-fault detection, the ground-fault trip level must be substantially below the prospective ground-fault current. In a solidly grounded system, prospective ground-fault current is similar to phase-fault current. In a resistance-grounded system, prospective ground-fault current is defined by the neutral-grounding-resistor let-through-current rating.

In a solidly grounded system, protection against arcing ground faults requires a ground-fault CT that will detect low-level fault current but not saturate up to the operating value of the system overcurrent protection. In general, immunity to saturation is proportional to CT mass.

To eliminate nuisance tripping, surge current must not saturate the CT.

For low-level ground-fault protection use an EFCT-1, EFCT-2, or EFCT-26 earth-fault CT with a 5-A-primary rating. However, protection at this level might not be possible because of high surge current or prospective ground-fault current.

For CT-selection assistance, see Technical Note CT-01 available at [www.littelfuse.com/relayscontrols](http://www.littelfuse.com/relayscontrols).

## 2. OPERATION

### 2.1 CONFIGURATION-SWITCH SETTINGS

See Fig. 1.

#### 2.1.1 RELAY OPERATING MODE

Switch 1 is used to set the operating mode of the output relay. In the fail-safe mode, the output relay energizes when the ground-fault circuit is not tripped. In the fail-safe mode, non-volatile memory retains the trip status of the SE-701. If tripped, and the supply voltage is cycled, the SE-701 will remain tripped, with the trip relay de-energized and the TRIP LED on, until reset.

In the non-fail-safe mode, the output relay energizes when a ground-fault trip occurs. In the non-fail-safe mode, trip status is not retained in non-volatile memory.

#### 2.1.2 TRIP INHIBIT

Switch 2 is used to select Class I or Class II operation. In the OFF position, high-current trip inhibit is off for Class I operation. In the ON position, high-current trip inhibit is on for Class II operation. If high-current trip inhibit is on and ground-fault current escalates above eleven times the CT-primary rating before the ground-fault circuit trips, the output relay will not operate until ground-fault current falls below eight times the CT-primary rating. This feature allows overcurrent protection to operate in applications where the ground-fault current can be larger than the interrupting capacity of the device tripped by the SE-701.

#### 2.1.3 CT VERIFICATION

Switch 3 is used to enable CT verification with an EFCT-series CT. In the ON position, a trip will occur if the CT is disconnected. Switch 3 must be in the OFF position when an EFCT-series CT is not used and must be in the ON position when an EFCT is used.

#### 2.1.4 FILTER SELECTION

Switch 4 is used to select the filtering algorithm for a fixed-frequency (50/60 Hz) or variable-frequency application. The FIXED FREQUENCY setting uses a DFT filter that allows lower trip levels to be used by rejecting harmonics that can cause nuisance tripping.

The VARIABLE FREQUENCY setting uses a peak-detection algorithm with a wider bandwidth for fault detection in variable-frequency drive applications.

#### 2.1.5 RESET MODE

Switch 5 is used to select autoreset or latching trips. See Section 2.2.3.

## 2.2 FRONT-PANEL CONTROLS

### 2.2.1 GROUND-FAULT TRIP LEVEL

The % CT PRIMARY selector switches are used to set the ground-fault trip level as a percentage of the CT-primary rating.

In tripping systems, a ground-fault trip level of 10 to 20% of the prospective ground-fault current is often used. In alarm-only systems, a value of 50% of the prospective ground-fault current is often used. To avoid sympathetic tripping, the trip level must be above the charging current of the protected feeder.

A 0% selection provides protection at 1%.

### 2.2.2 GROUND-FAULT TRIP TIME

The SE-701 has a definite-time trip characteristic. The TIME (s) selector switch is used to set the ground-fault trip delay time for coordination with upstream and downstream ground-fault devices. Coordination requires the same trip level for all ground-fault devices in a system and the trip time to progressively increase upstream. The amount of equipment removed from the system will be a minimum if the first ground-fault device to operate is the one immediately upstream from the fault.

### 2.2.3 RESET

If the Reset Mode switch is in the LATCHING position, a trip remains latched until the RESET button is pressed or the remote-reset terminals are momentarily connected. In the non-fail-safe mode, cycling the supply voltage will also reset the SE-701.

If the Reset Mode switch is in the AUTORESET position, a trip will reset when the fault is removed.

The reset circuit responds only to a momentary closure so that a jammed or shorted button will not prevent a trip. The front-panel RESET button is inoperative when the remote-reset terminals (6 and 7) are connected.

### 2.2.4 TEST

The TEST button is used to test the ground-fault circuit, the indication, and the output relay. When the TEST button is pressed for one second, a test signal is applied to the ground-fault-detection circuit, the circuit will trip, the TRIP LED will light, and the output relay will operate. If high-current inhibit has been selected, the INHB LED will light.

## 2.3 FRONT-PANEL INDICATION

### 2.3.1 POWER

The green LED labelled PWR indicates the presence of supply voltage.

### 2.3.2 TRIP

The red LED labelled TRIP indicates a trip. A solid red LED indicates a ground-fault trip. A flashing LED

indicates a trip initiated by a CT fault. Two fast flashes indicate a diagnostic trip. See Section 2.5.

### 2.3.3 TRIP INHIBIT

The yellow LED labelled INHB indicates that output-relay operation was inhibited during a high-current ground fault. See Section 2.1.2. When a ground-fault trip occurs during a high-current ground fault, both the TRIP and INHB LED's will be ON. Inhibit indication is reset when the ground-fault trip is reset. Inhibit operation and indication will not respond if the trip-inhibit switch is in the OFF position.

## 2.4 ANALOG OUTPUT

The non-isolated, 0- to 5-V analog output indicates ground-fault current sensed by the ground-fault CT. The output is 5 V when ground-fault current is 100% of the CT-primary rating. Use a PGA-0500 Analog Percent Current Meter with the PGA-05CV Voltage Converter to indicate ground-fault current. See Figs. 2, 3, and 11.

## 2.5 SELF DIAGNOSTICS

A diagnostic trip is indicated by two fast flashes of the TRIP LED. It can be caused by a diagnostic problem detected by the watchdog timer or from an incorrect reading from non-volatile memory. Press RESET or cycle supply voltage. If the problem persists, contact Littelfuse Startco.

### 3. INSTALLATION

**NOTE:** Mounting, terminal-block connections, and wiring must conform to applicable local electrical codes. Check all applicable codes prior to installation.

An SE-701 can be surface or DIN-rail-mounted. See Fig. 1. Panel mounting requires a PMA-55 or PMA-60 Panel-Mount Adapter. See Figs. 9 and 10.

Use terminal 11 (L1) as the line terminal on ac supply systems or the positive terminal on dc supply systems. Use Terminal 10 (L2/N) as the neutral terminal on ac systems or the negative terminal on dc systems. Connect terminal 9 ( $\oplus$ ) to ground.

Pass the phase conductors through the CT window—for 4-wire and single-phase systems also pass the neutral conductor through the CT window, as shown in Figs. 2 and 3. Do not pass ground conductors through the CT window. In applications that require shields or drain wires to pass through the CT window, return them through the CT window before connecting them to ground. If a ground-fault CT with a 5-A secondary is used, connect it to terminals 2 and 3 (terminals 1 and 3 with a 1-A secondary) and ground terminal 3. If an EFCT-x is used, connect it to terminals 4 and 5, connect the shield to terminal 5, and ground terminal 5. Set configuration switch 3 to ON. Remove the connection to terminal 9 for dielectric-strength testing—all inputs and outputs have ANSI/IEEE C37.90 surge-protection circuits that conduct above 300 Vac. See Figs. 4, 5, and 6 for EFCT-series dimensional drawings and Figs. 6, 7, and 8 for the SE-CS30-series current sensors.

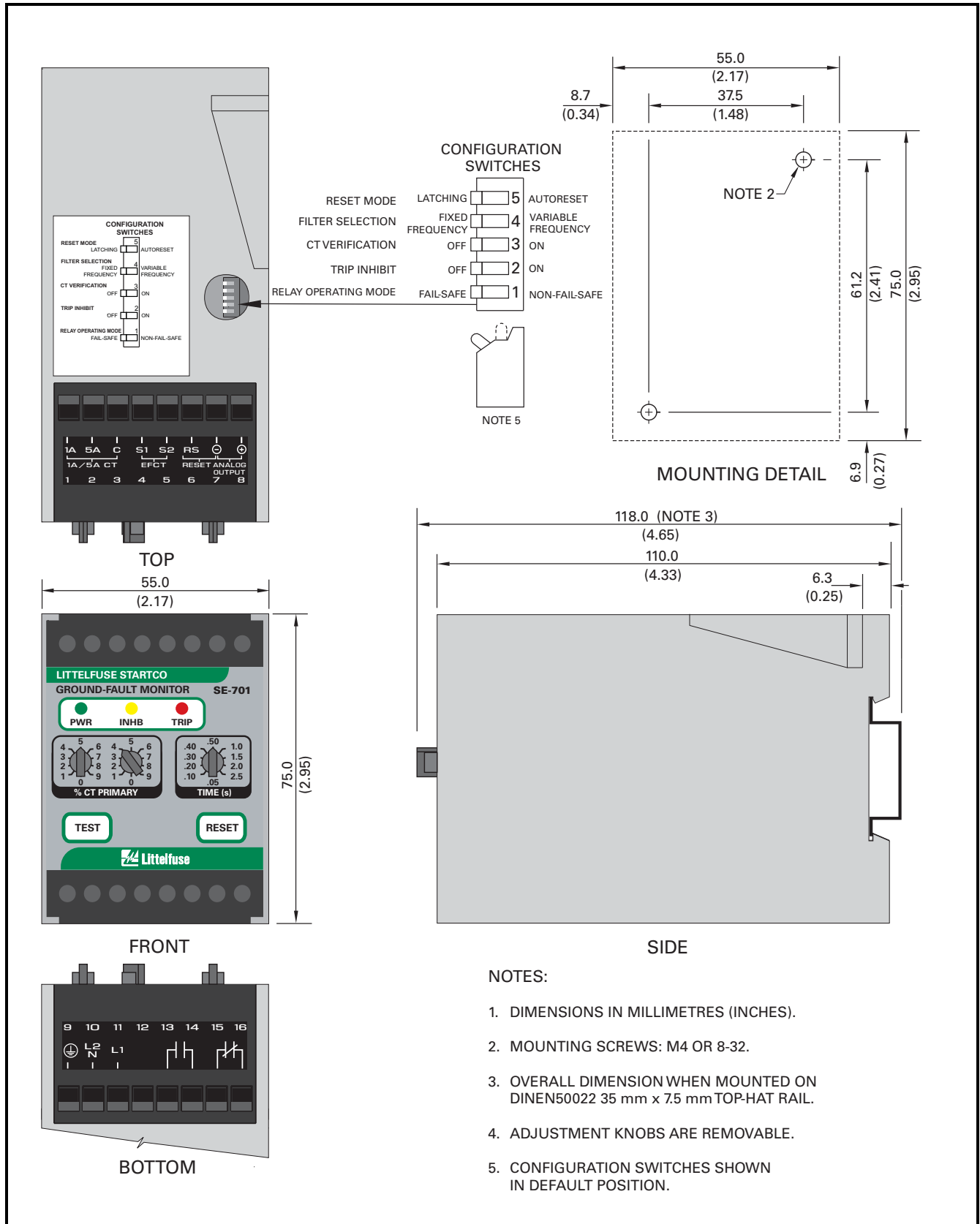

FIGURE 1. SE-701 Outline and Mounting Details.



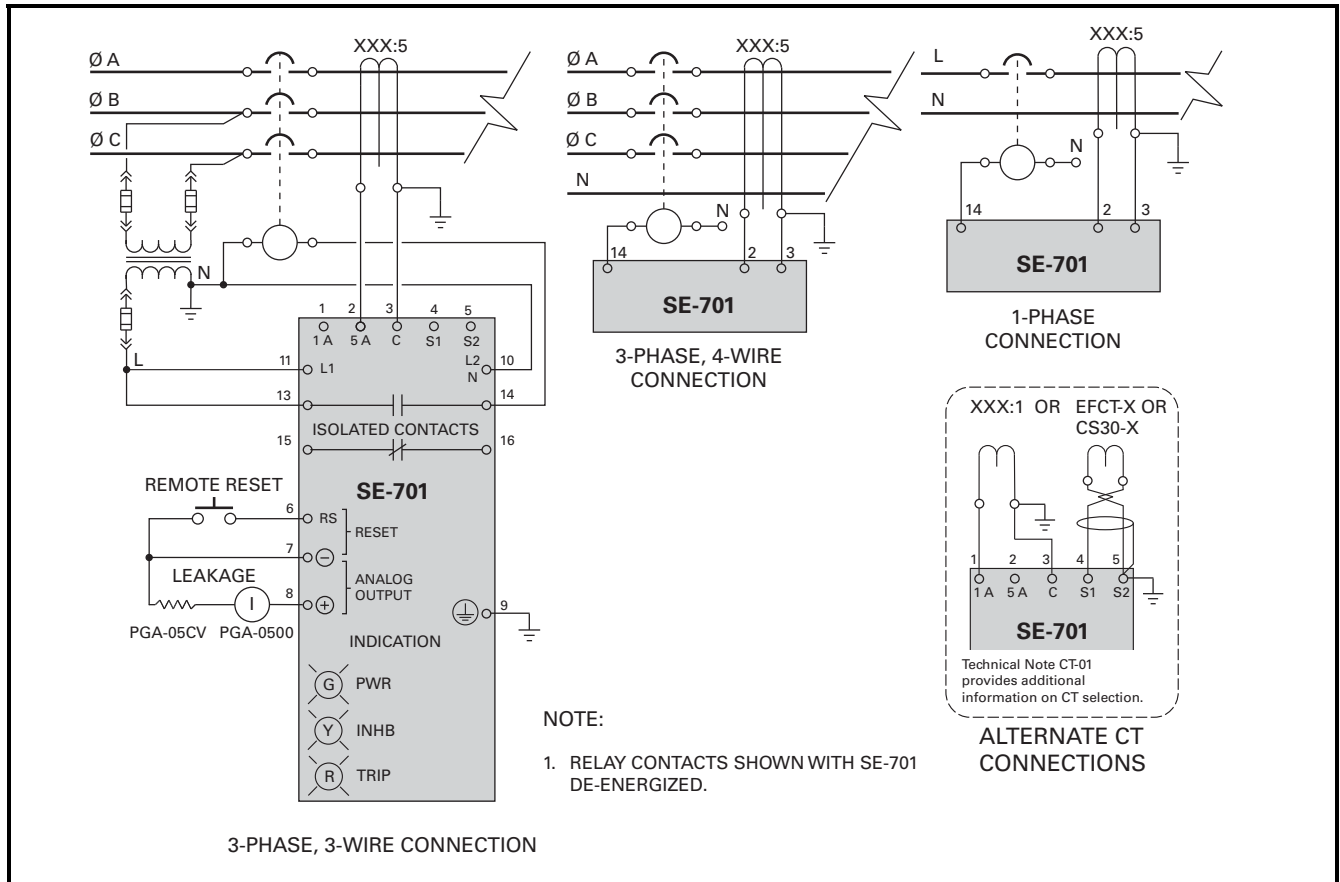

FIGURE 2. Typical Connection Diagrams.

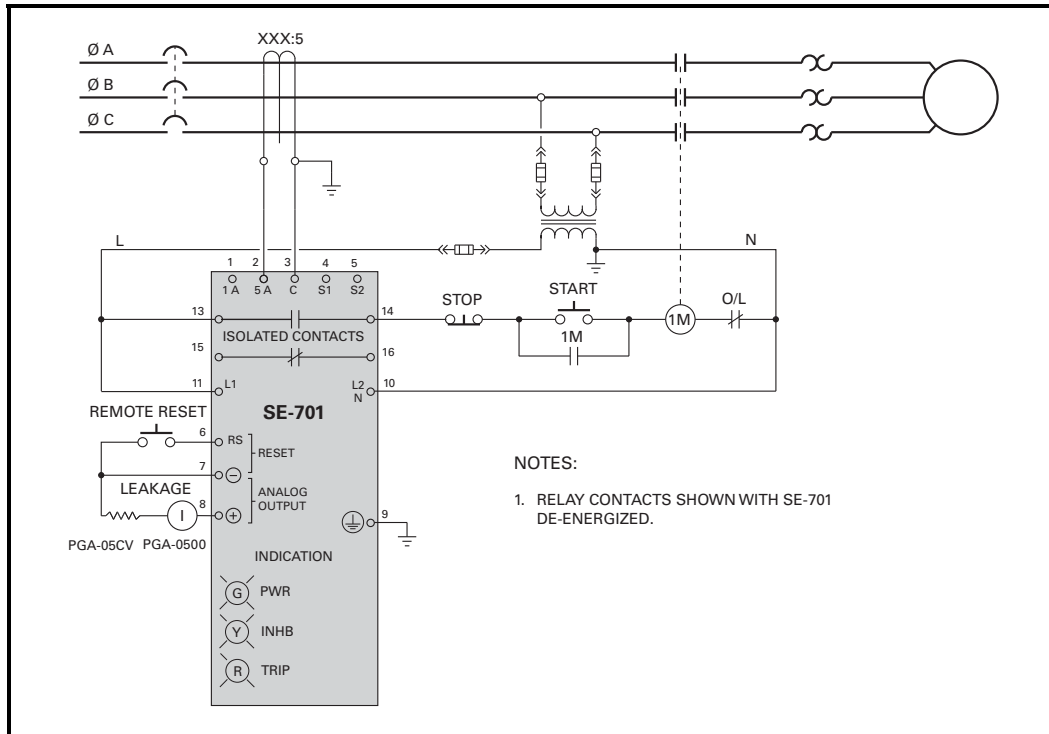

FIGURE 3. Typical Three-Phase-Starter Connection.

#### 4. SE-701 COMPATIBILITY

The current SE-701 has been enhanced with the addition of non-volatile trip memory for the fail-safe relay operating mode. Prior to hardware revision 07, a mechanical flag was used instead of non-volatile trip memory. The current revision of the SE-701 can directly replace previous revision 00 to 06 units. Beginning with hardware revision 09, CT verification must be enabled when used with an EFCT-series earth-fault CT. Previous-revision SE-701 units used with EFCT-series CT's can operate with CT verification enabled or disabled. See Section 2.1.3. The hardware-revision number is listed on the SE-701 model/serial-number label affixed to the SE-701 enclosure. The SE-701 generations are compared in Table 1.

The SE-701 was previously available with SE-701-01 120-Vac and SE-701-02 240-Vac supply-voltage options. These have been discontinued. An SE-701-0U 120/240 Vac/Vdc unit can directly replace an SE-701-01 or SE-701-02.

TABLE 1. TRIP-FEATURES COMPARISON

		HARDWARE REVISION		
		00 to 06	≥ 07	≥ 09
LED trip indication		Yes	Yes	
Mechanical flag trip indication		Yes	No	
Non-volatile trip memory		No	Yes	
Device state after supply voltage cycled when tripped (ground-fault removed)	Fail-safe	Trip LED: Off Trip relay: Energized Trip flag: Red	Trip LED: On Trip relay: De-energized	
	Non-fail-safe	Trip LED: Off Trip relay: De-energized Trip flag: Red	Trip LED: Off Trip relay: De-energized	
CT Detection must be ON for EFCT		No	No	Yes

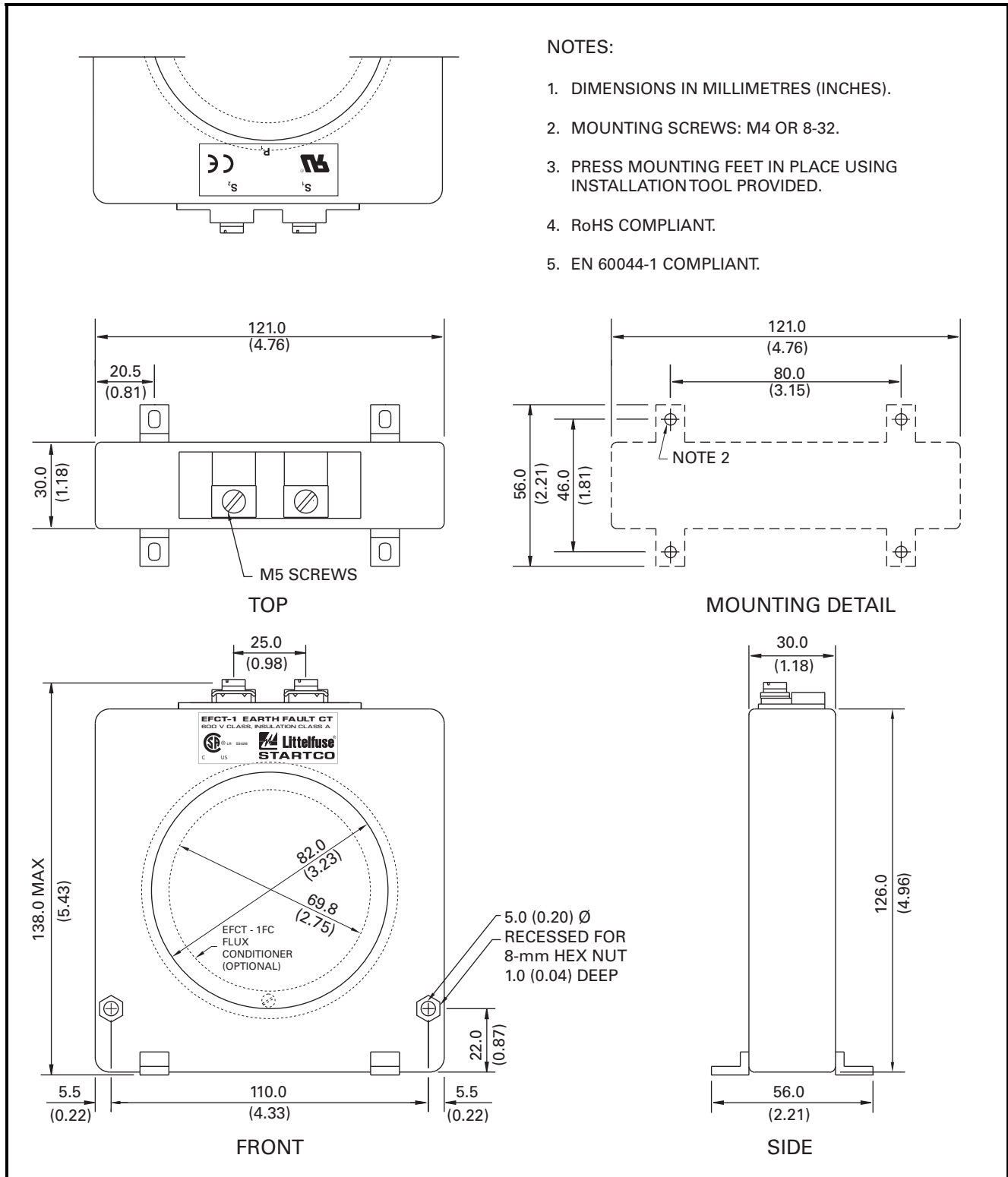

FIGURE 4. EFCT-1 Outline and Mounting Details.

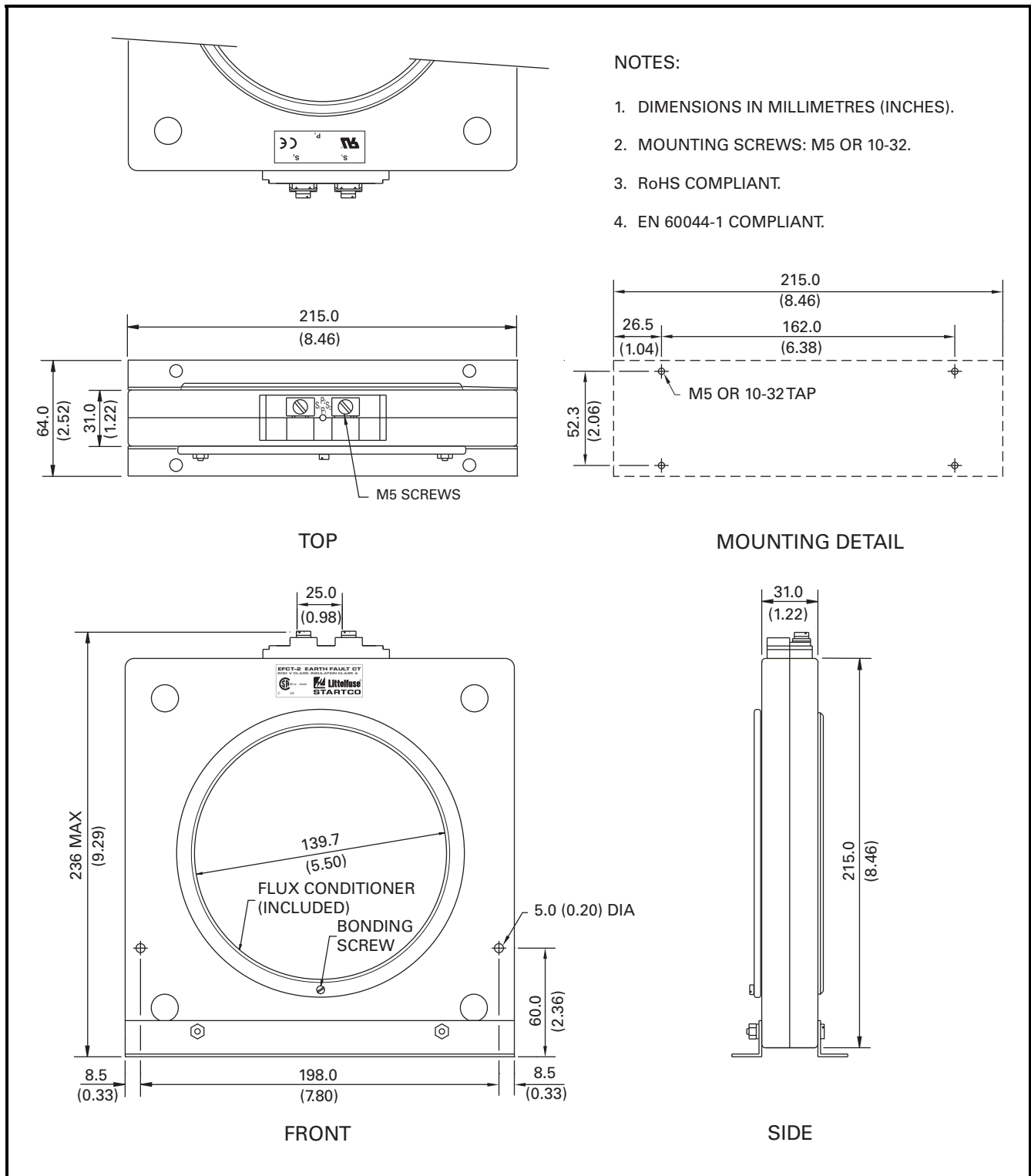

FIGURE 5. EFCT-2 Outline and Mounting Details.

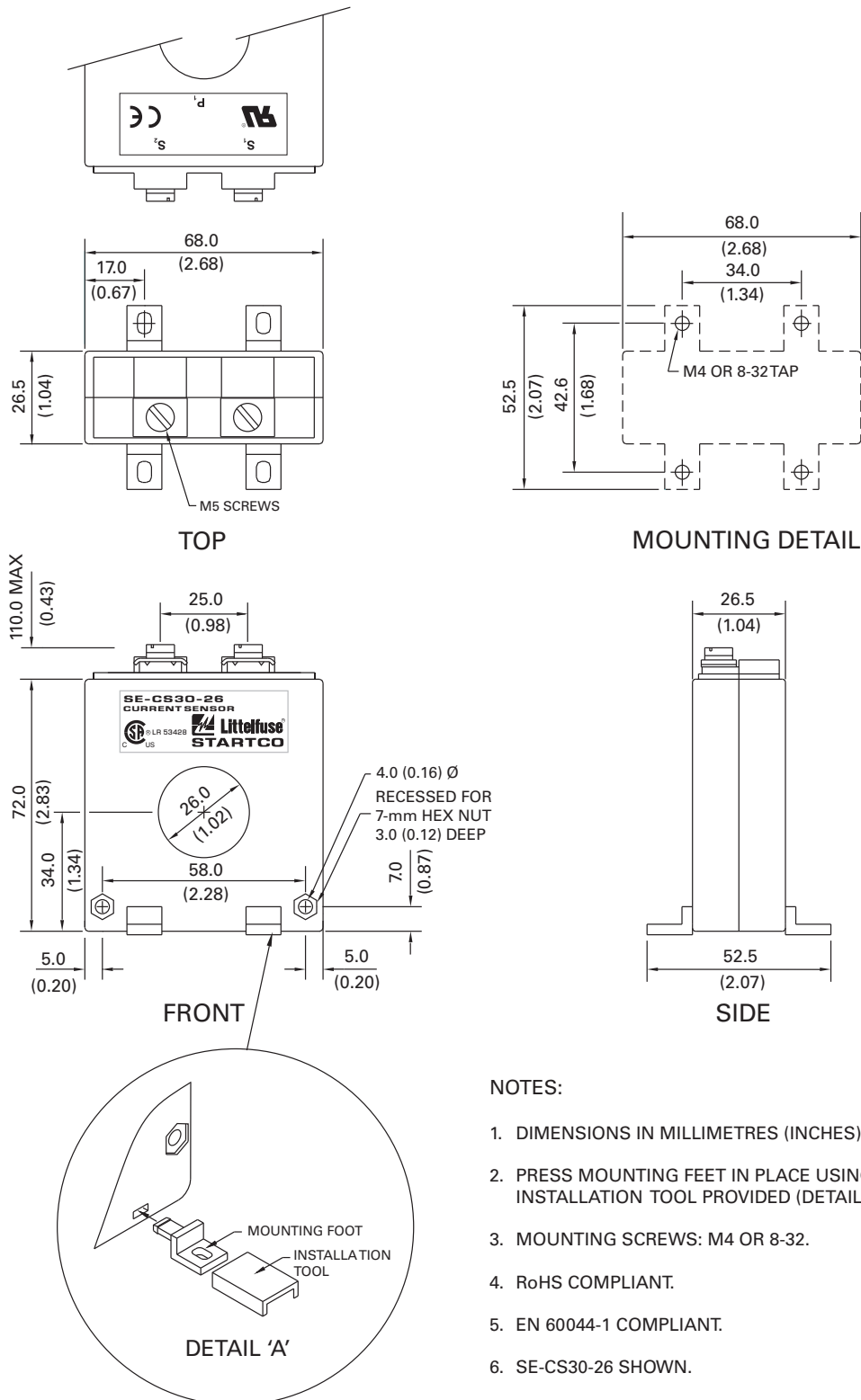

FIGURE 6. EFCT-26 and SE-CS30-26 Outline and Mounting Details.

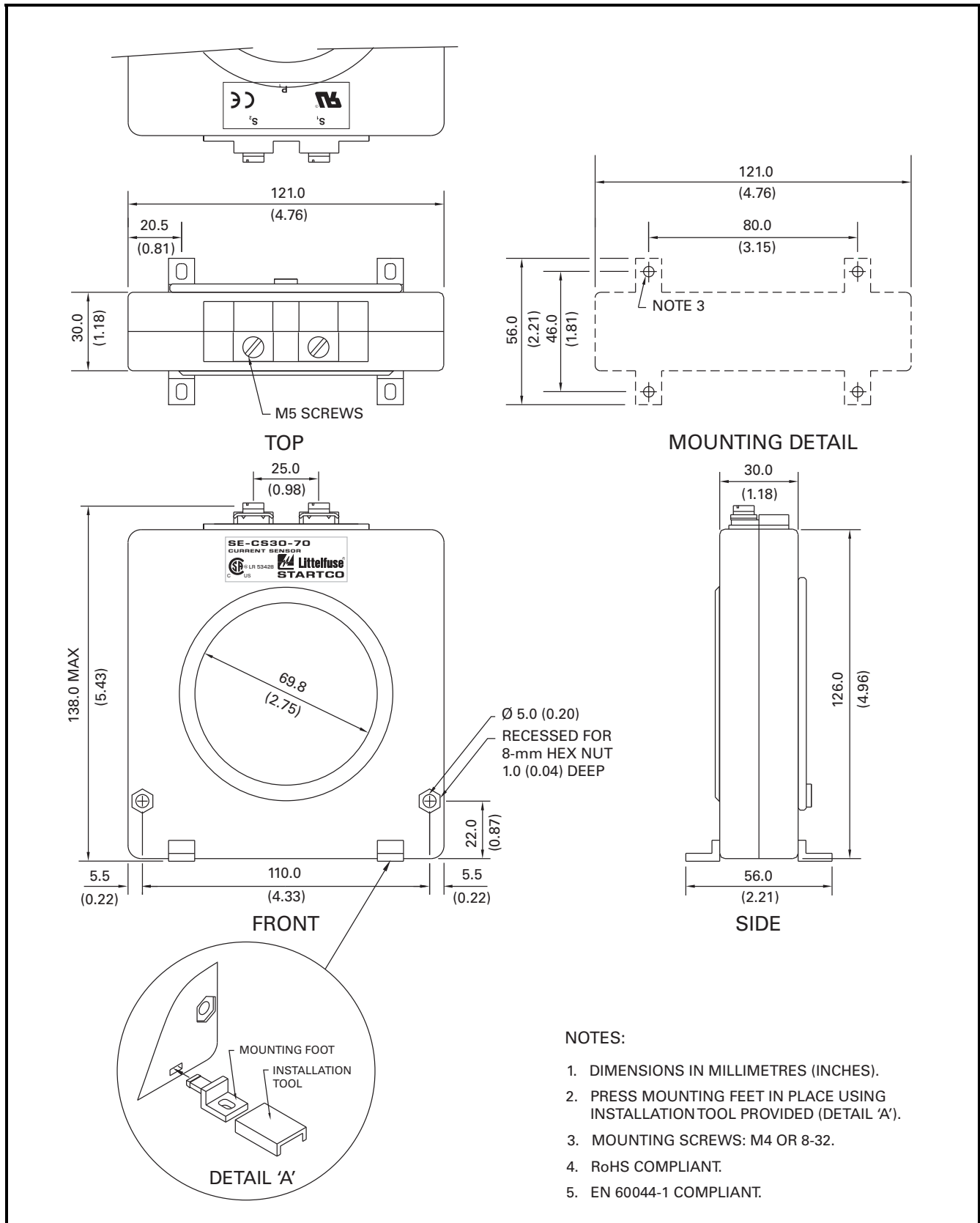

FIGURE 7. SE-CS30-70 Current Sensor.

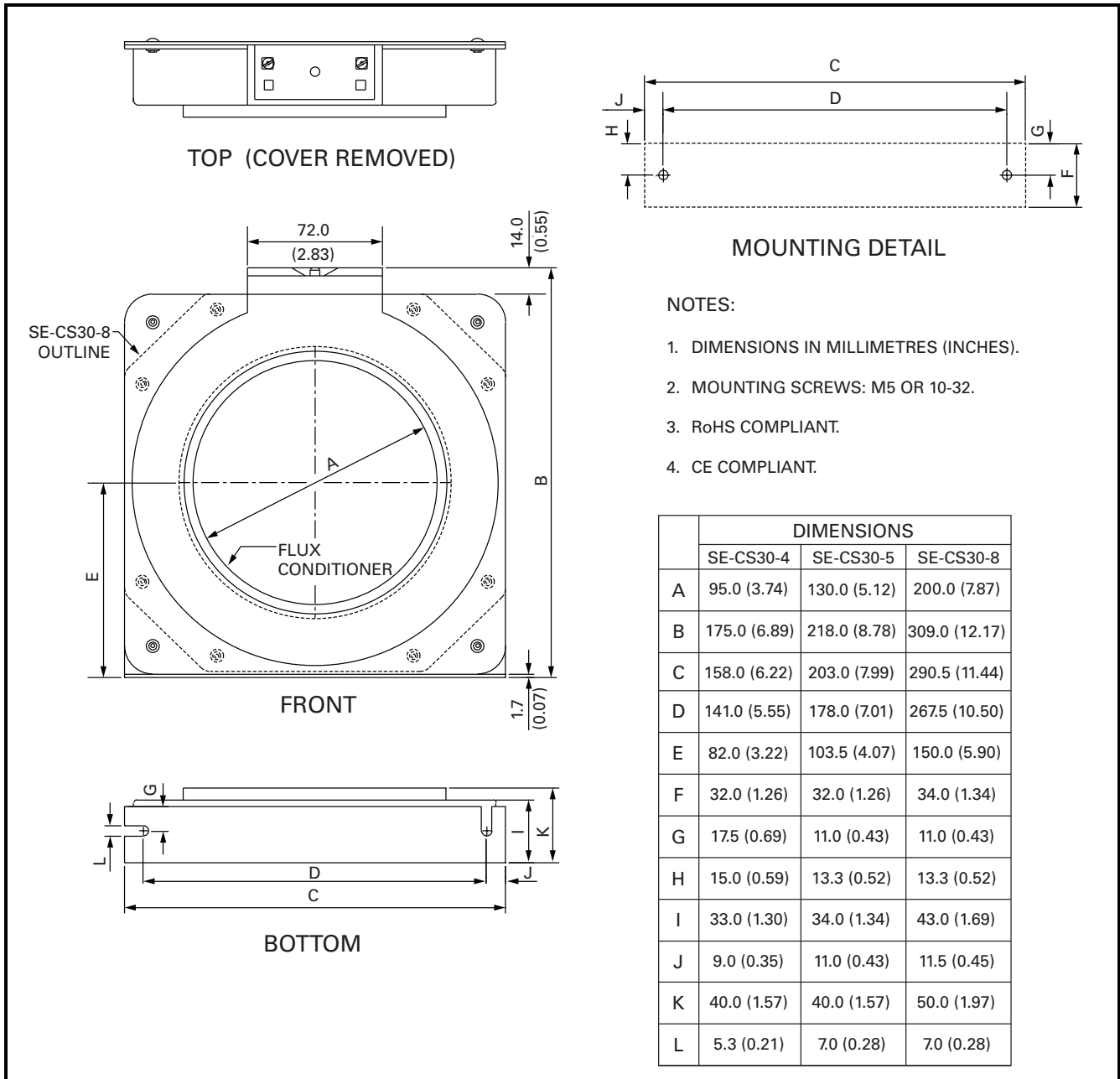

FIGURE 8. SE-CS30-4, -5, and -8 Current Sensors.

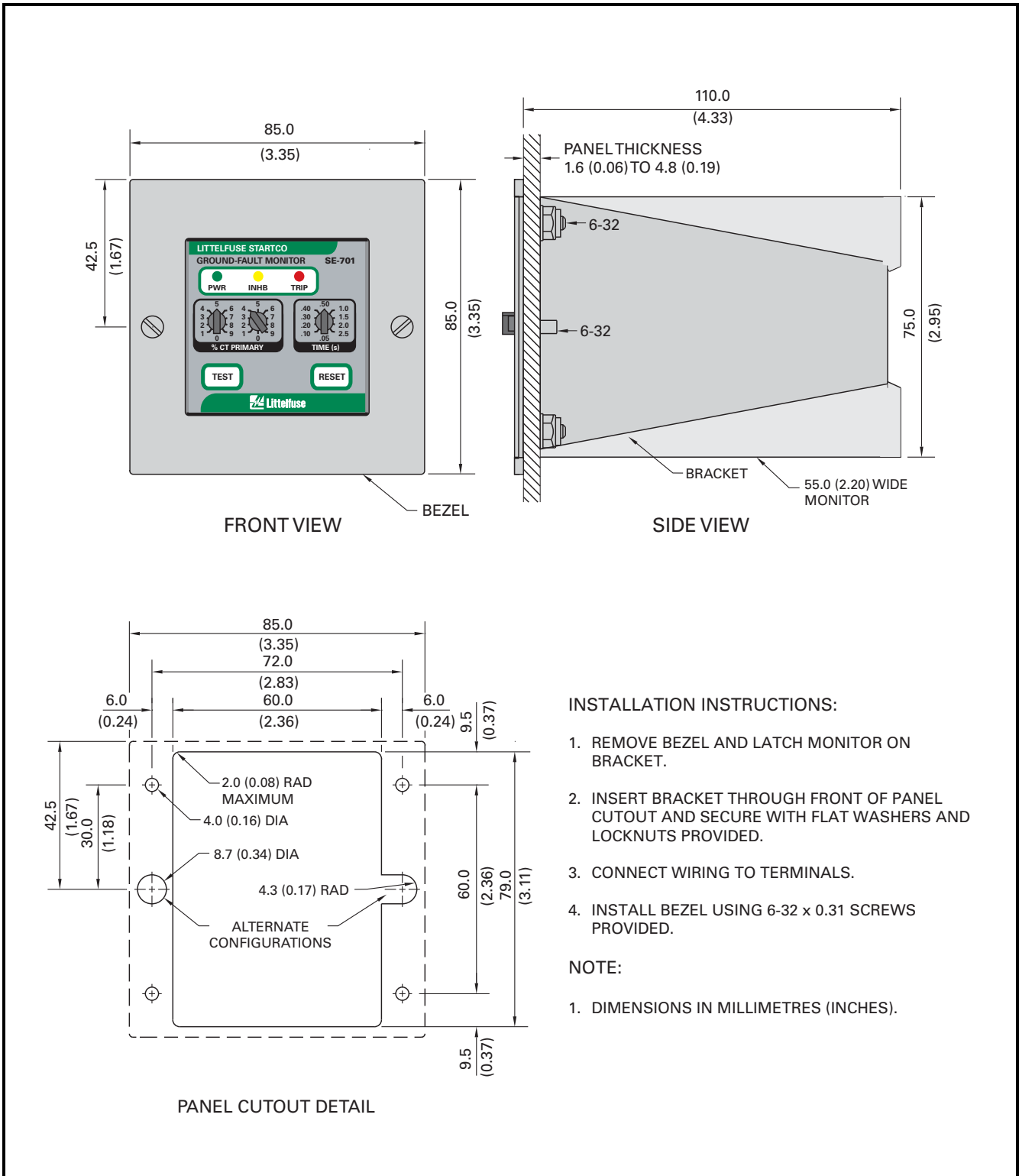

FIGURE 9. PMA-55 Panel-Mount Adapter.



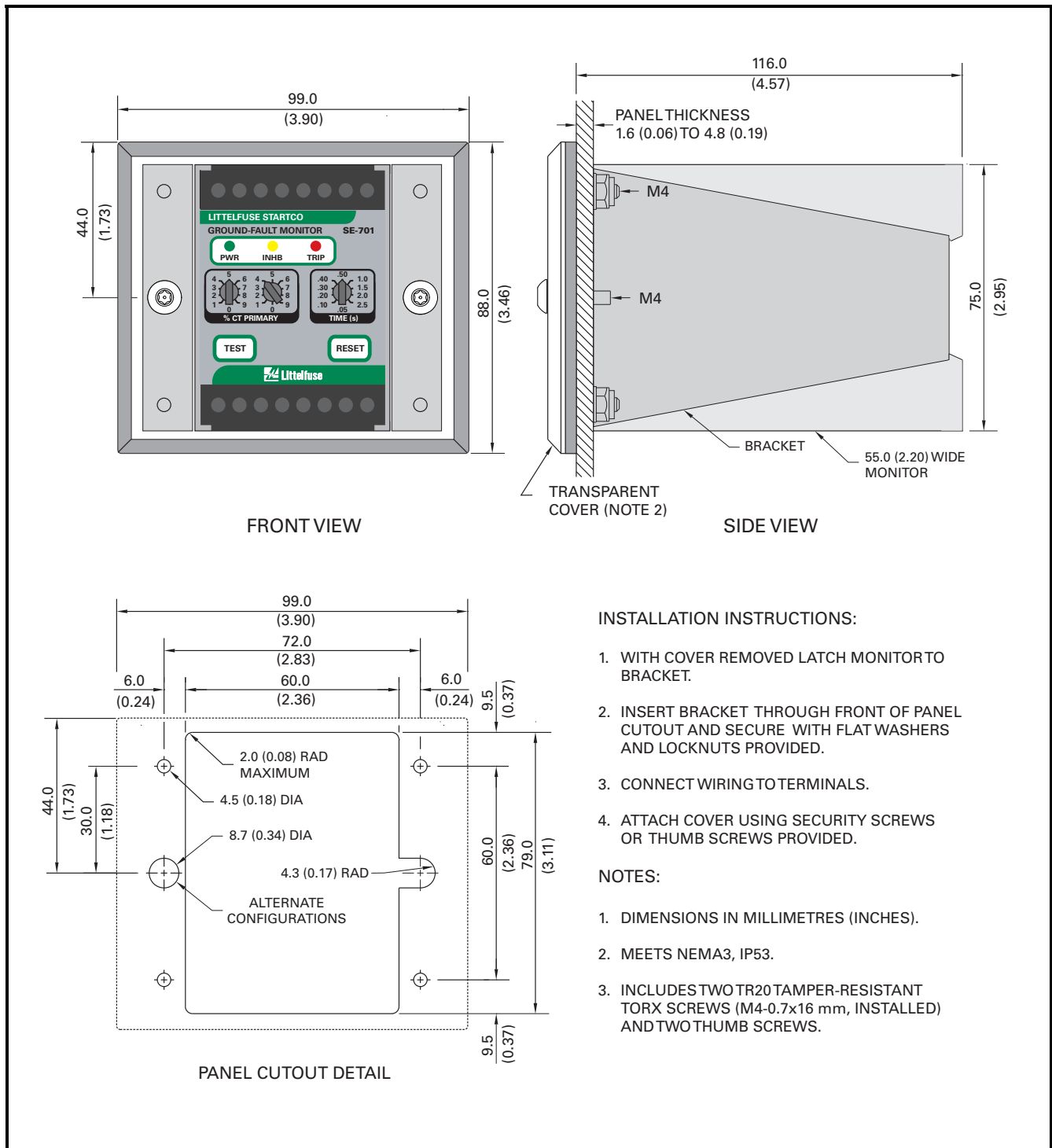

FIGURE 10. PMA-60 Panel-Mount Adapter.

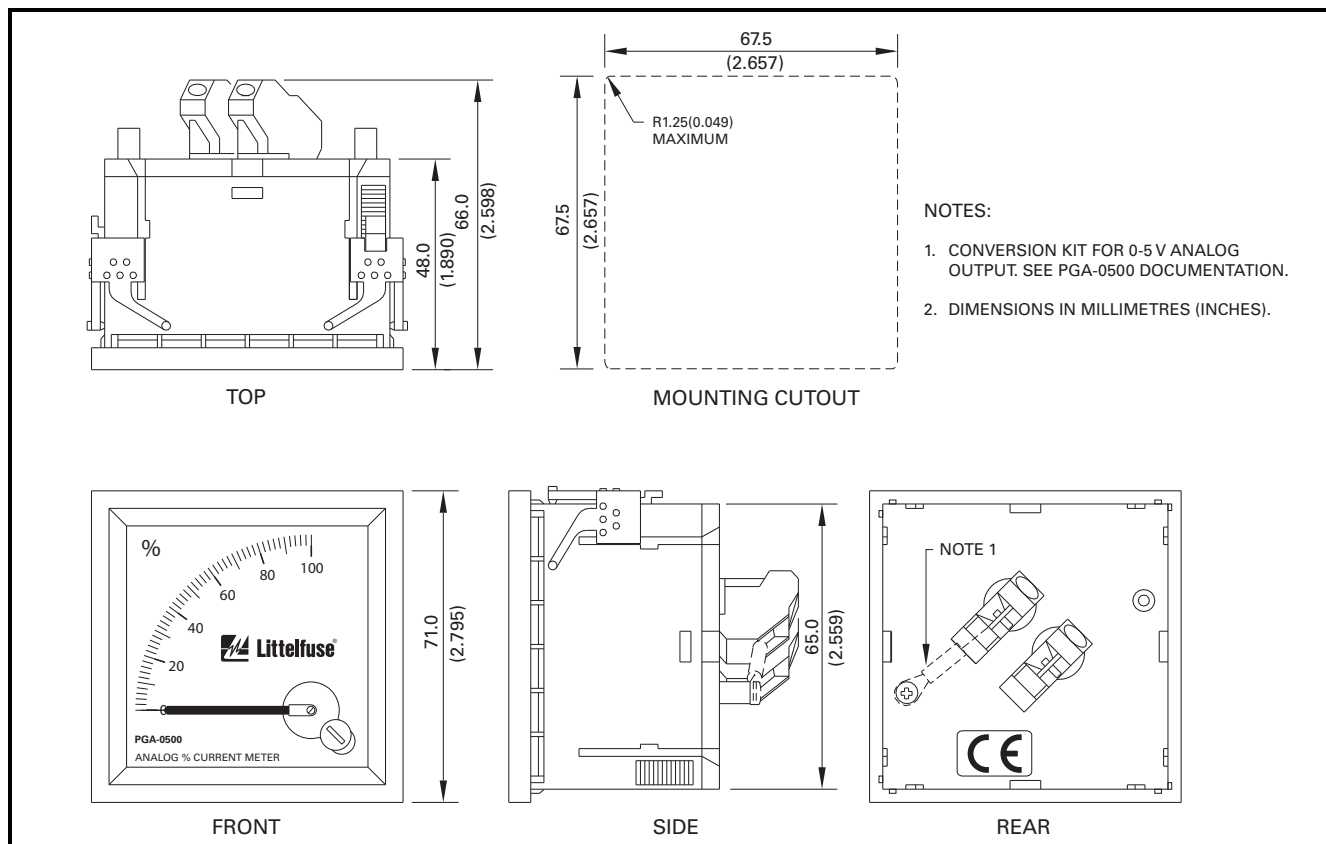

FIGURE 11. PGA-0500 Analog Percent Current Meter.

## 5. TECHNICAL SPECIFICATIONS

### Supply:

0U Option	5 VA, 120 to 240 Vac, (+20, -55%) 50/60 Hz; 2 W, 100 to 240 Vdc, (+20, -25%)
0D Option	2 W, 12 to 30 Vdc, (+20, -25%)
0T Option	2 W, 40 to 55 Vdc, (+20, -25%)
03 Option	2.5 VA, 24 Vac, (+15, -40%), 50/60 Hz

Trip-Level Range..... 1 to 99% CT-Primary  
Rating in 1% increments  
(50 mA to 4.95 A with  
EFCT-x)

Trip-Time Settings..... 0.05, 0.10, 0.20, 0.30,  
0.40, 0.50, 1.0, 1.5, 2.0,  
and 2.5 s

### Accuracies <sup>(1)</sup>:

Trip Level <sup>(2)</sup> ..... Largest of 5% of setting or:

#### 1-A input:

1% setting ..... -10, +15 mA  
2 - 99% setting ..... 10 mA

#### 5-A and EFCT <sup>(4)</sup> inputs:

1% setting ..... -35, +60 mA  
2 - 99% setting ..... 35 mA

Trip Time <sup>(3)</sup> ..... 5% of setting  
(-25, +20 ms minimum)

### Trip Inhibit:

Off ..... Class I  
On ..... Class II  
Level ..... 11 x CT-Primary Rating

### Input:

Algorithms ..... DFT or Peak  
DFT 3 dB Frequency Resp ... 32 to 86 Hz  
Peak 3 dB Frequency Resp ... 20 to 420 Hz  
CT ..... 1- or 5-A Secondary  
Rating, or EFCT-x  
CT Detection ..... Open-Circuit Detection  
with EFCT-x

<p>Thermal Withstand:</p> <p>  Continuous..... 5 x CT-Secondary Rating</p> <p>  1-Second..... 80 x CT-Secondary Rating</p> <p>Burden:</p> <p>  5-A input..... &lt; 0.01 Ω</p> <p>  1-A input..... &lt; 0.05 Ω</p> <p>  EFCT input..... 2 Ω</p> <p>Analog Output:</p> <p>  Range..... 0 to 5 Vdc,                     5 V = 100% CT Rating</p> <p>  Output Impedance..... 220 Ω</p> <p>Reset ..... Front-Panel Button and                     Remote N.O. Momentary                     Contact</p> <p>Functional Test..... Front-Panel Button</p> <p>Output Relay:</p> <p>  Contact Configuration..... Isolated N.O. and N.C.</p> <p>  Operating Mode..... Fail-Safe or Non-Fail-Safe</p> <p>  CSA/UL Contact Rating.... 8 A General Use, 250 Vac,                                     8 A Resistive, 30 Vdc                                     0.25 HP, 120/240 Vac</p> <p>Supplemental Contact Ratings:</p> <p>  Carry Current..... 8 A, maximum</p> <p>  Break:</p> <p>    30 Vdc..... 240 W Resistive,                     170 W Inductive                     (L/R=7 ms)</p> <p>    120 Vdc..... 24 W Resistive,                     17 W Inductive (L/R=7 ms)</p> <p>    ac..... 2,000 VA Resistive,                     875 VA Inductive                     (PF = 0.4)</p> <p>    (Subjct to maximums of 8 A and 250 Vac/     30 Vdc or 200 mA at 120 Vdc)</p> <p>Trip Mode..... Latching or Autoreset</p> <p>Terminals..... Wire-clamping,                     24 to 12 AWG                     (0.2 to 2.5 mm<sup>2</sup>)                     conductors</p> <p>Dimensions:</p> <p>  Height..... 75 mm (3.0")</p> <p>  Width..... 55 mm (2.2")</p> <p>  Depth..... 113 mm (4.5")</p> <p>Shipping Weight..... 0.45 kg (1 lb)</p>	<p>Environment:</p> <p>  Operating Temperature:</p> <p>    Altitude:</p> <p>      ≤ 1,000 m (3,281')..... -40 to 60°C                                     (-40 to 140°F)</p> <p>      3,000 m (9,843')..... -40 to 55°C                                     (-40 to 131°F)</p> <p>      5,000 m (16,404')..... -40 to 50°C                                     (-40 to 122°F)</p> <p>  Storage Temperature..... -55 to 80°C                                     (-67 to 160°F)</p> <p>  Humidity..... 85% Non-Condensing</p> <p>  Altitude..... 5,000 m (16,404')                     maximum</p> <p>PWB Conformal Coating..... MIL-1-46058 qualified                                     UL QMJU2 recognized</p> <p>Surge Withstand..... ANSI/IEEE 37.90.1-1989                                     (Oscillatory and Fast                                     Transient)</p> <p>Vibration..... EN60255-21-1 (Vibration,                     Shock, and Seismic)                     EN60255-21-2 (Shock and                     Bump)</p> <p>EMC Tests:</p> <p>  Verification tested in accordance with EN 50263:2000</p> <p>    Radiated and Conducted</p> <p>    Emissions..... CISPR 11:2009,                     CISPR 22:2008,                     EN55022:2010                     Class A</p> <p>  Current Harmonics and   Voltage Fluctuation..... IEC 61000-3-2 and                                     IEC 61000-3-3                                     Class A</p> <p>Electrostatic Discharge..... IEC 61000-4-2                                     ± 6 kV contact discharge                                     (direct and indirect)                                     ± 8 kV air discharge</p> <p>Radiated RF Immunity..... IEC 61000-4-3                                     10 V/m, 80-1000 MHz,                                     80% AM (1 kHz)                                     10 V/m, 900 MHz,                                     200 Hz pulse modulated</p>
---	--

Fast Transient .....	IEC 61000-4-4 ±4 kV on AC mains and I/O lines
Surge Immunity .....	IEC 61000-4-5 Zone B ± 1 kV differential mode ± 2 kV common mode
Conducted RF Immunity ...	IEC 61000-4-6 10 V, 0.15-80 MHz, 80% AM (1 kHz)
Magnetic Field Immunity ...	IEC 61000-4-8 50 Hz and 60 Hz , 30 A/m and 300 A/m
Voltage Interruption .....	IEC 61000-4-11, IEC 61000-4-29, 0% for 5, 10, 20, 50, 100 & 200 ms 3x each
Power Frequency .....	IEC 61000-4-16 Zone A: differential mode 150 Vrms Zone A: common mode 300 Vrms
1 MHz Burst .....	IEC 61000-4-18 ± 1 kV differential mode (line-to-line) ± 2.5 kV common mode
RFI Compliance .....	FCC Part 15, Subpart B, Class A – Unintentional Radiators

Certification.....CSA, Canada and USA



Australia



FCC



CE, European Union



Complies to IEC 61010-1:2001 (2<sup>nd</sup> Edition);  
EN 61010-1:2001 (2<sup>nd</sup> Edition) Safety Requirements  
for Electrical Equipment for Measurement, Control,  
and Laboratory Use – Part 1.

**NOTES:**

- (1) Over operating temperature range of -40 to 60°C (-40 to 140°F).
- (2) CT accuracy not included.
- (3) Trip time at 3 x trip-level setting from the first peak.
- (4) For maximum lead resistance of 1 Ω.

**6. ORDERING INFORMATION**

SE-701-0□-□□

Conformal Coating:  
Blank – Partial Conformal Coating  
CC – Full Conformal Coating

Supply:  
3 – 24-Vac Supply  
U – Universal 120/240-Vac/Vdc Supply  
D – 12/24-Vdc Supply  
T – 48-Vdc Supply

EFCT-1 .....	Earth-Fault CT, 5-A-primary rating, 82 mm (3.2”) window
EFCT-1FC .....	Flux Conditioner for EFCT-1, 70 mm (2.7”) window
EFCT-2 .....	Earth-Fault CT, with Flux Conditioner, 5-A-primary rating, 139 mm (5.5”) window
EFCT-26 .....	Earth-Fault CT, 5-A-primary rating, 26 mm (1”) window

(All EFCT’s include 6 m (19.2’) 22 AWG (0.3 mm<sup>2</sup>)  
shielded cable.)

SE-CS30-26.....	Current Sensor, 26.0 mm (1.02") window
SE-CS30-70.....	Current Sensor c/w Flux Conditioner, 69.8 mm (2.75") window
SE-CS30-4.....	Current Sensor c/w Flux Conditioner, 95.0 mm (3.74") window
SE-CS30-5.....	Current Sensor c/w Flux Conditioner, 130.0 mm (5.12") window
SE-CS30-8.....	Current Sensor c/w Flux Conditioner, 200.0 mm (7.87") window
5SHT-101-E <sup>(1)</sup> .....	Current Sensor, 100-A-primary rating, 40 mm (1.6") window
5SHT-151-E <sup>(1)</sup> .....	Current Sensor, 150-A-primary rating, 40 mm (1.6") window
5SHT-500-E <sup>(1)</sup> .....	Current Sensor, 50-A-primary rating, 40 mm (1.6") window
7SHT-301-E <sup>(1)</sup> .....	Current Sensor, 300-A-primary rating, 64 mm (2.5") window
7SHT-401-E <sup>(1)</sup> .....	Current Sensor, 400-A-primary rating, 64 mm (2.5") window
PGA-0500.....	Analog Percent Current Meter (PGA-05CV included)
PMA-55.....	Panel-Mount Adapter, NEMA 1
PMA-60.....	Panel-Mount Adapter, NEMA 3, IP53. Includes two TR20 tamper-resistant Torx screws and two thumb screws.
PMA-3.....	Adapter Plate, GES/MCGG
PMA-6.....	Adapter Plate, FPL-GFRM
PMA-15.....	Adapter Plate, MGFR
SE-EFVC.....	Voltage Clamp

Consult factory for custom mounting adapters.

**NOTES:**

<sup>(1)</sup> Includes mounting brackets.

**7. WARRANTY**

The SE-701 Ground-Fault Monitor is warranted to be free from defects in material and workmanship for a period of five years from the date of purchase.

Littelfuse Startco will (at Littelfuse Startco's option) repair, replace, or refund the original purchase price of an SE-701 that is determined by Littelfuse Startco to be defective if it is returned to the factory, freight prepaid, within the warranty period. This warranty does not apply to repairs required as a result of misuse, negligence, an accident, improper installation, tampering, or insufficient care. Littelfuse Startco does not warrant products repaired or modified by non-Littelfuse Startco personnel.

## 8. GROUND-FAULT PERFORMANCE TEST

To meet the requirements of the National Electrical Code (NEC), as applicable, the overall ground-fault protection system requires a performance test when first installed. A written record of the performance test is to be retained by those in charge of the electrical installation in order to make it available to the authority having jurisdiction. A test-record form is provided for recording the date and the final results of the performance tests. The following ground-fault system tests are to be conducted by qualified personnel:

- Evaluate the interconnected system in accordance with the overall equipment manufacturer's detailed instructions.
- Verify proper location of the ground-fault current sensor. Ensure the cables pass through the ground-fault-current-sensor window. This check can be done visually with knowledge of the circuit. The connection of the current-sensor secondary to the SE-701 is not polarity sensitive.
- Verify that the system is correctly grounded and that alternate ground paths do not exist that bypass the current sensor. High-voltage testers and resistance bridges can be used to determine the existence of alternate ground paths.
- Verify proper reaction of the circuit-interrupting device in response to a simulated or controlled ground-fault current. To simulate ground-fault current, use CT-primary current injection. Fig. 12 (a) shows a test circuit using an SE-400 Ground-Fault-Relay Test Unit. The SE-400 has a programmable output of 0.5 to 9.9 A for a duration of 0.1 to 9.9 seconds. Set the test current to 120% of the SE-701 setting. Fig. 12 (b) shows a test circuit using an SE-100T Ground-Fault-Relay Tester. The SE-100T provides a test current of 0.65 or 2.75 A for testing 0.5- and 2.0-A trip levels. Inject the test current through the current-sensor window for at least 2.5 seconds. Verify that the circuit under test has reacted properly. Correct any problems and re-test until the proper reaction is verified.
- Record the date and the results of the test on the attached test-record form.

**NOTE:** Do not inject test current directly into CT-input terminals 1, 2, 3, 4, and 5.

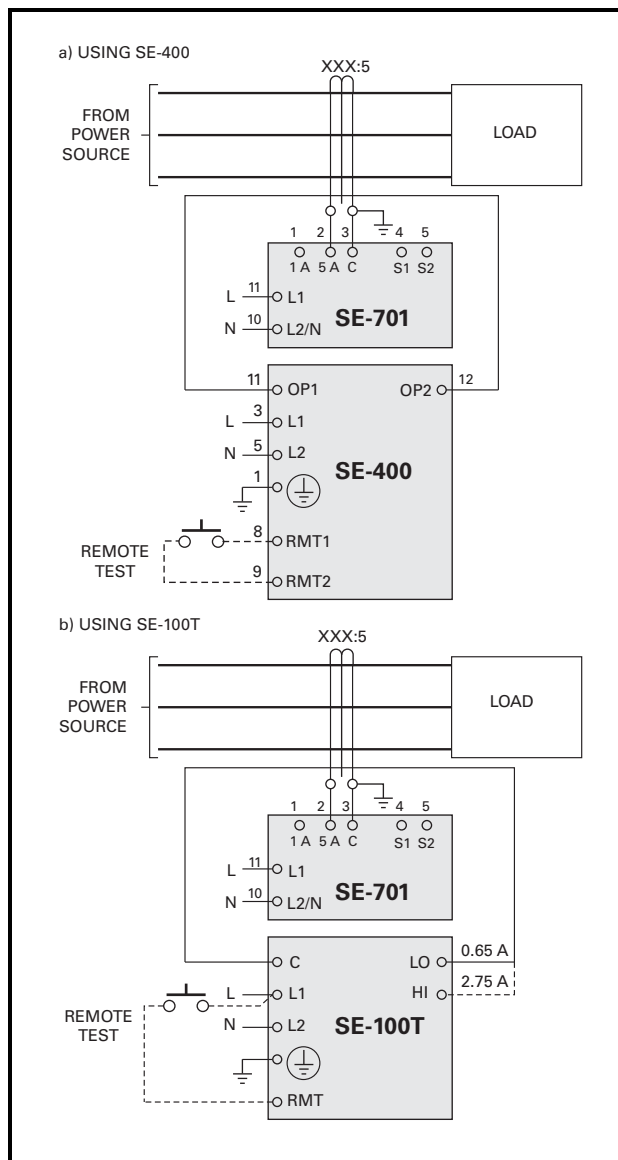

FIGURE 12. Ground-Fault-Test Circuits.



**APPENDIX A  
SE-701 REVISION HISTORY**

<b>MANUAL RELEASE DATE</b>	<b>MANUAL REVISION</b>	<b>PRODUCT REVISION (REVISION NUMBER ON PRODUCT LABEL)</b>
July 24, 2014	10-C-072414	09
October 21, 2013	10-B-102113	
April 12, 2013	10-A-041213	

**MANUAL REVISION HISTORY**

**REVISION 10-C-072414**

**SECTION 4**

Fig. 8 updated.

**SECTION 5**

Update to include altitude and vibration specifications.

**APPENDIX A**

Revision history updated.

**REVISION 10-B-102113**

**SECTION 4**

Fig. 6 updated to include EFCT-26 and SE-CS30-26.

**SECTION 5**

Conformal coating specifications added.  
FCC certification mark added.

**SECTION 6**

Updated ordering information with full conformal coating (CC) option.

**APPENDIX A**

Revision history updated.

**REVISION 10-A-041213**

**SECTION 3**

Figs. 2 and 3 updated to include PGA-05CV.

**SECTION 4**

Figs. 7, 8, and 9 added.

**SECTION 5**

Environment section updated to include Fahrenheit temperature range.

**SECTION 6**

Additional current sensors added to ordering information.

**APPENDIX A**

Revision history added.

**PRODUCT REVISION HISTORY**

**REVISION 09**

Firmware: Improved operation of front-panel test button.



Компания «Life Electronics» занимается поставками электронных компонентов импортного и отечественного производства от производителей и со складов крупных дистрибьюторов Европы, Америки и Азии.

С конца 2013 года компания активно расширяет линейку поставок компонентов по направлению коаксиальный кабель, кварцевые генераторы и конденсаторы (керамические, пленочные, электролитические), за счёт заключения дистрибьюторских договоров

Мы предлагаем:

- Конкуренспособные цены и скидки постоянным клиентам.
- Специальные условия для постоянных клиентов.
- Подбор аналогов.
- Поставку компонентов в любых объемах, удовлетворяющих вашим потребностям.
- Приемлемые сроки поставки, возможна ускоренная поставка.
- Доставку товара в любую точку России и стран СНГ.
- Комплексную поставку.
- Работу по проектам и поставку образцов.
- Формирование склада под заказчика.
- Сертификаты соответствия на поставляемую продукцию (по желанию клиента).
- Тестирование поставляемой продукции.
- Поставку компонентов, требующих военную и космическую приемку.
- Входной контроль качества.
- Наличие сертификата ISO.

В составе нашей компании организован Конструкторский отдел, призванный помогать разработчикам, и инженерам.

Конструкторский отдел помогает осуществить:

- Регистрацию проекта у производителя компонентов.
- Техническую поддержку проекта.
- Защиту от снятия компонента с производства.
- Оценку стоимости проекта по компонентам.
- Изготовление тестовой платы монтаж и пусконаладочные работы.



Тел: +7 (812) 336 43 04 (многоканальный)

Email: [org@lifeelectronics.ru](mailto:org@lifeelectronics.ru)