

Dual Photovoltaic MOSFET Driver Solid State Relay

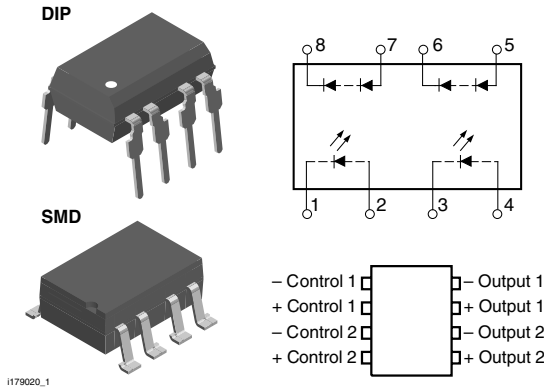

DESCRIPTION

The VO1263AB/AAC photovoltaic MOSFET driver consists of two LEDs optically coupled to two photodiode arrays. The photodiode array provides a floating source with adequate voltage and current to drive high-power MOSFET transistors. Optical coupling provides a high I/O isolation voltage. In order to turn the MOSFET off, an external resistance (gate-to-source) is required for gate discharge.

FEATURES

- High open circuit voltage, up to 14.6 V typical
- High short circuit current, up to 42 μ A typical
- Isolation test voltage 5300 V_{RMS}
- Logic compatible input
- High reliability
- Lead (Pb)-free component
- Component in accordance to RoHS 2002/95/EC and WEEE 2002/96/EC



RoHS
COMPLIANT

APPLICATIONS

- High-side driver
- Solid state relays
- Floating power supply
- Power control
- Data acquisition
- ATE
- Isolated switching

Note

See "solid state relays" (application note 56)

AGENCY APPROVALS

UL1577: file no. E52744 system code H or J, double protection

DIN EN: 60747-5-5

CUL: file no. E52744, equivalent to CSA bulletin 5A

ORDER INFORMATION		
PART	REMARKS	PACKAGE
VO1263AAC	Tubes	SMD-8
VO1263AACTR	Tape and reel	SMD-8
VO1263AB	Tubes	DIP-8

ABSOLUTE MAXIMUM RATINGS (1)				
PARAMETER	TEST CONDITION	SYMBOL	VALUE	UNIT
SSR				
LED input ratings continuous forward current		I _F	50	mA
LED input ratings reverse voltage	I _R ≤ 10 μ A	V _R	5.0	V
Photodiode array reverse voltage	I _R ≤ 2.0 μ A	V _R	100	V
Ambient operating temperature range		T _{amb}	- 40 to + 100	°C
Storage temperature range		T _{stg}	- 40 to + 150	°C
Pin soldering temperature (2)	t = 7.0 s max.	T _{slid}	270	°C
Input to output isolation voltage	t = 60 s min.	V _{ISO}	5300	V _{RMS}

Notes

(1) T_{amb} = 25 °C, unless otherwise specified.

Stresses in excess of the absolute maximum ratings can cause permanent damage to the device. Functional operation of the device is not implied at these or any other conditions in excess of those given in the operational sections of this document. Exposure to absolute maximum ratings for extended periods of the time can adversely affect reliability.

(2) Refer to reflow profile for soldering conditions for surface mounted devices (SMD). Refer to wave profile for soldering conditions for through hole devices (DIP).

ELECTRICAL CHARACTERISTICS						
PARAMETER	TEST CONDITION	SYMBOL	MIN.	TYP.	MAX.	UNIT
LED forward voltage	$I_F = 10 \text{ mA}$	V_F	1.2	1.3	1.6	V
Detector reverse voltage	$I_R = 2.0 \text{ }\mu\text{A}$	$V_{R(PDA)}$		350		V
Open circuit voltage (pins 5, 6 or 7, 8)	$I_F = 5.0 \text{ mA}$	V_{OC}		13.3		V
	$I_F = 10 \text{ mA}$	V_{OC}	10.3	13.8	16.5	V
	$I_F = 15 \text{ mA}$	V_{OC}		14		V
	$I_F = 20 \text{ mA}$	V_{OC}		14.3		V
	$I_F = 30 \text{ mA}$	V_{OC}		14.6		V
Short circuit current (pins 5, 6 or 7, 8)	$I_F = 5.0 \text{ mA}$	I_{SC}	3.0	6.0		μA
	$I_F = 10 \text{ mA}$	I_{SC}	7.5	15		μA
	$I_F = 15 \text{ mA}$	I_{SC}	11	22		μA
	$I_F = 20 \text{ mA}$	I_{SC}	15	30		μA
	$I_F = 30 \text{ mA}$	I_{SC}	21	42		μA

Note

$T_{amb} = 25 \text{ }^\circ\text{C}$, unless otherwise specified.

Minimum and maximum values are testing requirements. Typical values are characteristics of the device and are the result of engineering evaluations. Typical values are for information only and are not part of the testing requirements.

SAFETY AND INSULATION RATINGS						
PARAMETER	TEST CONDITION	SYMBOL	MIN.	TYP.	MAX.	UNIT
Climatic classification (according to IEC 68 part 1)				40/100/21		
Comparative tracking index		CTI	175		399	
V_{IOTM}			8000			V
V_{IORM}			630			V
P_{SO}					500	mW
I_{SI}					300	mA
T_{SI}					175	$^\circ\text{C}$
Creepage distance			7			mm
Clearance distance			7			mm

FUNCTIONAL DESCRIPTION

Figure 1 outlines the IV characteristics of the illuminated photodiode array (PDA). For operation at voltages below V_{OC} , the PDA acts as a nearly constant current source. The actual region of operation depends upon the load.

The amount of current applied to the LED (pins 1 and 2 or 3 and 4) determines the amount of light produced for the PDA. For high temperature operation, more LED current may be required.



VO1263AAC/VO1263AACTR/VO1263AB

Dual Photovoltaic MOSFET Driver Solid State Relay Vishay Semiconductors

TYPICAL CHARACTERISTICS

$T_{amb} = 25\text{ }^{\circ}\text{C}$, unless otherwise specified

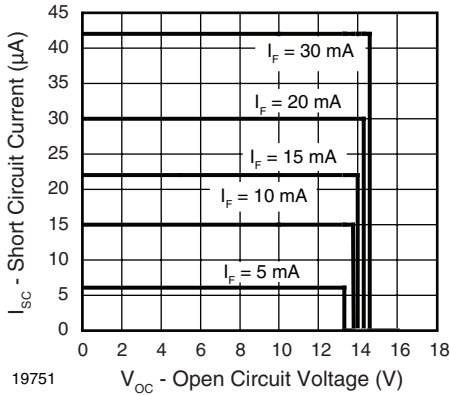

Fig. 1 - Short Circuit Current vs. Open Circuit Voltage

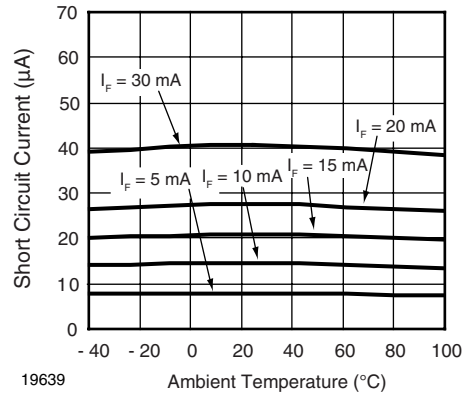

Fig. 4 - Short Circuit Current vs. Temperature

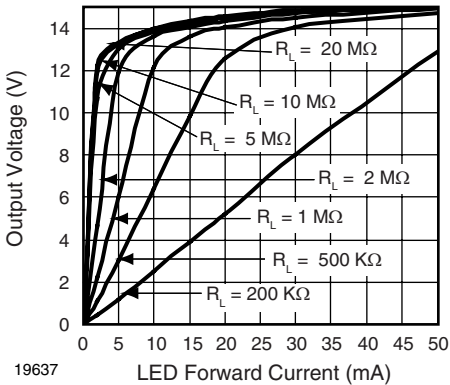

Fig. 2 - Output Voltage vs. LED Current

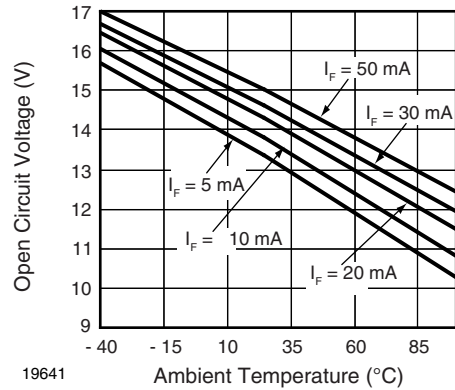

Fig. 5 - Open Circuit Voltage vs. Temperature

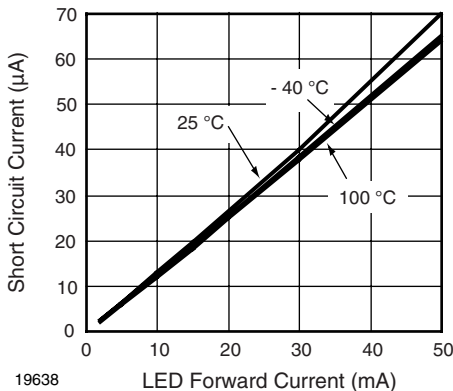

Fig. 3 - I_{sc} vs. LED Forward Current

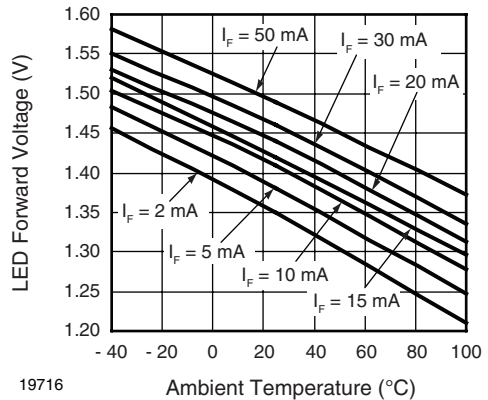
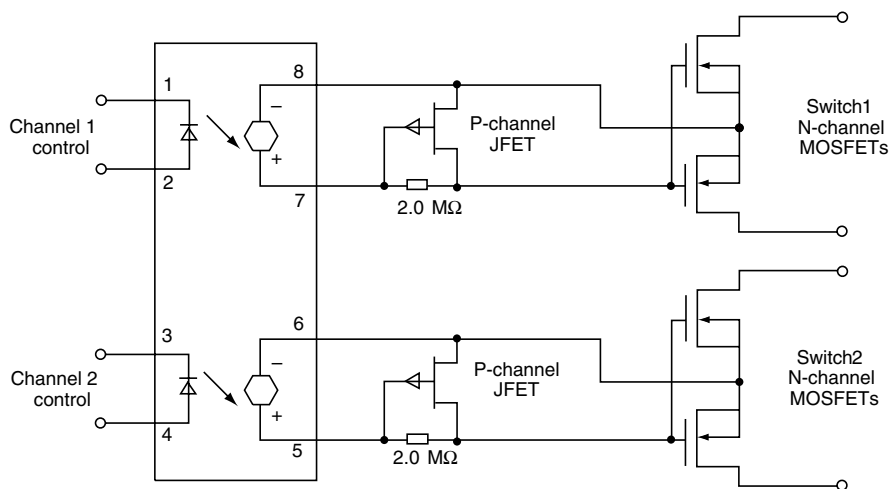

Fig. 6 - LED Forward Voltage vs. Temperature

VO1263AAC/VO1263AACTR/VO1263AB

Vishay Semiconductors Dual Photovoltaic MOSFET Driver Solid State Relay



ih1262cb_09

Fig. 7 - Typical Dual Form A Solid State Relay Application



VO1263AAC/VO1263AACTR/VO1263AB

Dual Photovoltaic MOSFET Driver Solid State Relay Vishay Semiconductors

PACKAGE DIMENSIONS in inches (millimeters)

DIP

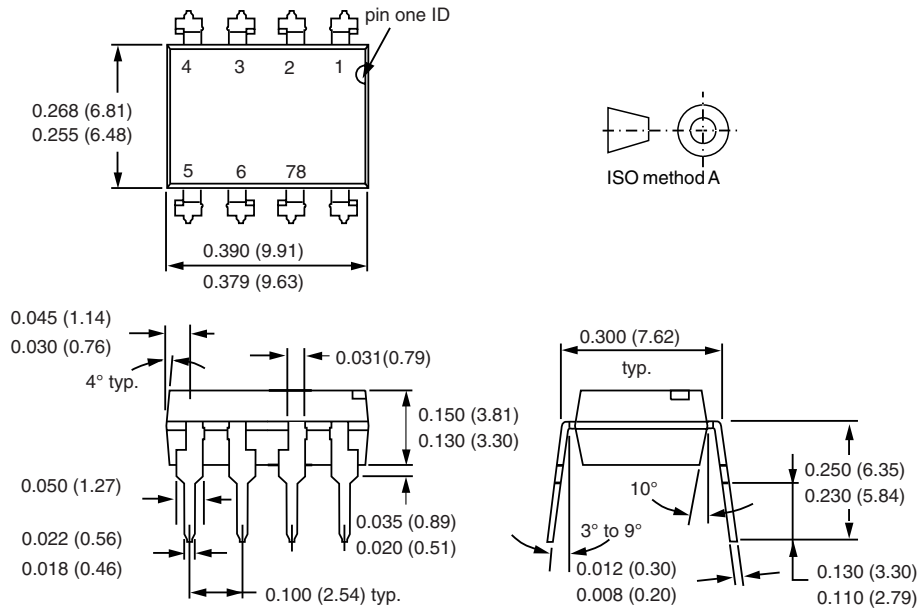

i178008

SMD

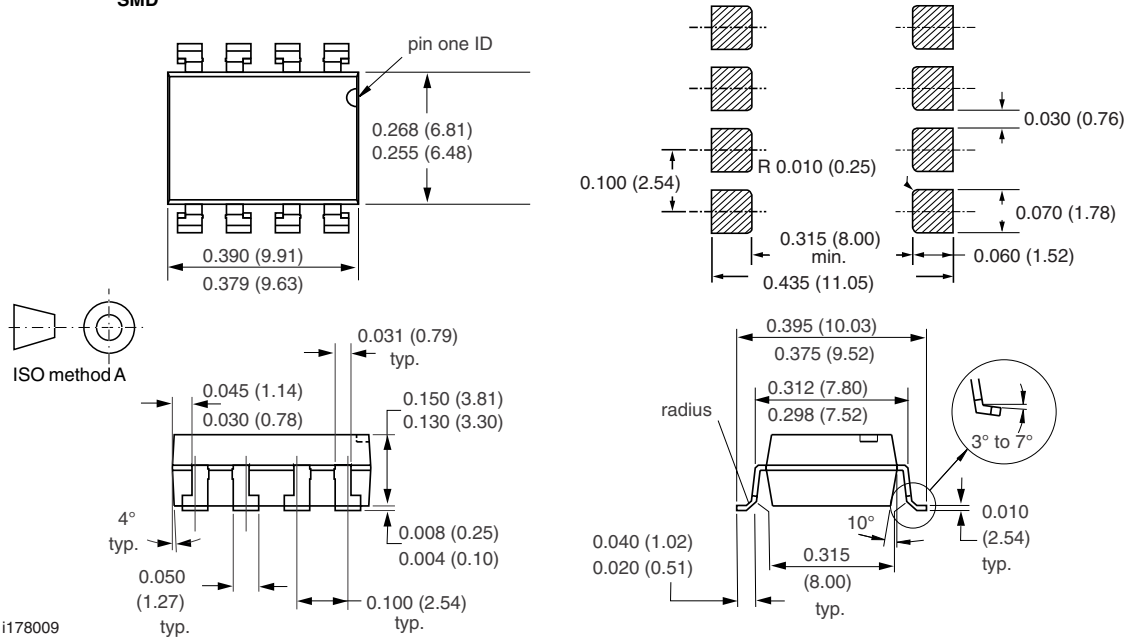

i178009



OZONE DEPLETING SUBSTANCES POLICY STATEMENT

It is the policy of Vishay Semiconductor GmbH to

1. Meet all present and future national and international statutory requirements.
2. Regularly and continuously improve the performance of our products, processes, distribution and operating systems with respect to their impact on the health and safety of our employees and the public, as well as their impact on the environment.

It is particular concern to control or eliminate releases of those substances into the atmosphere which are known as ozone depleting substances (ODSs).

The Montreal Protocol (1987) and its London Amendments (1990) intend to severely restrict the use of ODSs and forbid their use within the next ten years. Various national and international initiatives are pressing for an earlier ban on these substances.

Vishay Semiconductor GmbH has been able to use its policy of continuous improvements to eliminate the use of ODSs listed in the following documents.

1. Annex A, B and list of transitional substances of the Montreal Protocol and the London Amendments respectively.
2. Class I and II ozone depleting substances in the Clean Air Act Amendments of 1990 by the Environmental Protection Agency (EPA) in the USA.
3. Council Decision 88/540/EEC and 91/690/EEC Annex A, B and C (transitional substances) respectively.

Vishay Semiconductor GmbH can certify that our semiconductors are not manufactured with ozone depleting substances and do not contain such substances.

We reserve the right to make changes to improve technical design
and may do so without further notice.

Parameters can vary in different applications. All operating parameters must be validated for each customer application by the customer. Should the buyer use Vishay Semiconductors products for any unintended or unauthorized application, the buyer shall indemnify Vishay Semiconductors against all claims, costs, damages, and expenses, arising out of, directly or indirectly, any claim of personal damage, injury or death associated with such unintended or unauthorized use.

Vishay Semiconductor GmbH, P.O.B. 3535, D-74025 Heilbronn, Germany



Disclaimer

All product specifications and data are subject to change without notice.

Vishay Intertechnology, Inc., its affiliates, agents, and employees, and all persons acting on its or their behalf (collectively, "Vishay"), disclaim any and all liability for any errors, inaccuracies or incompleteness contained herein or in any other disclosure relating to any product.

Vishay disclaims any and all liability arising out of the use or application of any product described herein or of any information provided herein to the maximum extent permitted by law. The product specifications do not expand or otherwise modify Vishay's terms and conditions of purchase, including but not limited to the warranty expressed therein, which apply to these products.

No license, express or implied, by estoppel or otherwise, to any intellectual property rights is granted by this document or by any conduct of Vishay.

The products shown herein are not designed for use in medical, life-saving, or life-sustaining applications unless otherwise expressly indicated. Customers using or selling Vishay products not expressly indicated for use in such applications do so entirely at their own risk and agree to fully indemnify Vishay for any damages arising or resulting from such use or sale. Please contact authorized Vishay personnel to obtain written terms and conditions regarding products designed for such applications.

Product names and markings noted herein may be trademarks of their respective owners.

Компания «Life Electronics» занимается поставками электронных компонентов импортного и отечественного производства от производителей и со складов крупных дистрибьюторов Европы, Америки и Азии.

С конца 2013 года компания активно расширяет линейку поставок компонентов по направлению коаксиальный кабель, кварцевые генераторы и конденсаторы (керамические, пленочные, электролитические), за счёт заключения дистрибьюторских договоров

Мы предлагаем:

- Конкуренспособные цены и скидки постоянным клиентам.
- Специальные условия для постоянных клиентов.
- Подбор аналогов.
- Поставку компонентов в любых объемах, удовлетворяющих вашим потребностям.
- Приемлемые сроки поставки, возможна ускоренная поставка.
- Доставку товара в любую точку России и стран СНГ.
- Комплексную поставку.
- Работу по проектам и поставку образцов.
- Формирование склада под заказчика.
- Сертификаты соответствия на поставляемую продукцию (по желанию клиента).
- Тестирование поставляемой продукции.
- Поставку компонентов, требующих военную и космическую приемку.
- Входной контроль качества.
- Наличие сертификата ISO.

В составе нашей компании организован Конструкторский отдел, призванный помогать разработчикам, и инженерам.

Конструкторский отдел помогает осуществить:

- Регистрацию проекта у производителя компонентов.
- Техническую поддержку проекта.
- Защиту от снятия компонента с производства.
- Оценку стоимости проекта по компонентам.
- Изготовление тестовой платы монтаж и пусконаладочные работы.



Тел: +7 (812) 336 43 04 (многоканальный)
Email: org@lifeelectronics.ru