

## FEATURES

2.25 V to 5.5 V operating voltage range

Low power consumption (4  $\mu$ A)

High voltage (22 V) tolerance on inputs

Output stages

**ADCMP370:** open-drain, high voltage (22 V tolerance)

**ADCMP371:** push-pull

50 nA input bias current

150 nA input offset current

9 mV input offset voltage

Rail-to-rail, common-mode input range

Specified over  $-40^{\circ}\text{C}$  to  $+85^{\circ}\text{C}$  temperature range

5-lead SC70 packaging

## APPLICATIONS

Voltage detectors

Battery management systems

Analog-to-digital converters

Low voltage applications

Battery-powered electronics

Portable equipment

## GENERAL DESCRIPTION

The **ADCMP370/ADCMP371** are general-purpose comparators with input offset voltages of 9 mV (maximum) and low power consumption, which make them ideal for battery-powered, portable equipment.

The **ADCMP371** has a push-pull output stage, while the **ADCMP370** has an open-drain output. The inputs on both parts and the output on the **ADCMP370** can tolerate voltages up to 22 V, making them suitable for use as voltage detectors in portable equipment.

The devices are available in space-efficient, 5-lead SC70 packaging.

## FUNCTIONAL BLOCK DIAGRAMS

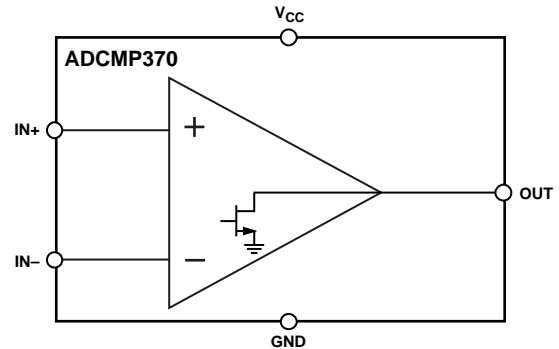

Figure 1.

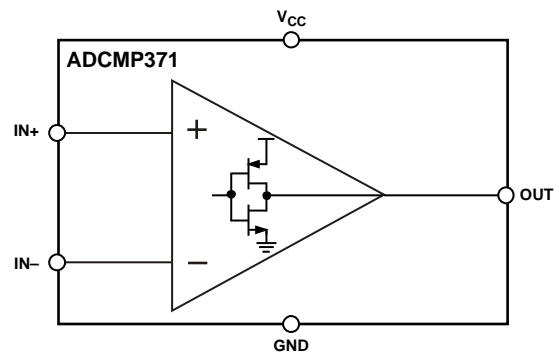

Figure 2.

Rev. D

[Document Feedback](#)

Information furnished by Analog Devices is believed to be accurate and reliable. However, no responsibility is assumed by Analog Devices for its use, nor for any infringements of patents or other rights of third parties that may result from its use. Specifications subject to change without notice. No license is granted by implication or otherwise under any patent or patent rights of Analog Devices. Trademarks and registered trademarks are the property of their respective owners.

**TABLE OF CONTENTS**

|                                |   |  |    |
|--------------------------------|---|--|----|
| Features .....                 | 1 | Pin Configuration and Function Descriptions..... | 5  |
| Applications.....              | 1 | Typical Performance Characteristics .....        | 6  |
| General Description .....      | 1 | Applications.....                                | 9  |
| Functional Block Diagrams..... | 1 | Basic Comparator .....                           | 9  |
| Revision History .....         | 2 | Adding Hysteresis.....                           | 9  |
| Specifications.....            | 3 | Outline Dimensions .....                         | 11 |
| Absolute Maximum Ratings.....  | 4 | Ordering Guide .....                             | 11 |
| ESD Caution.....               | 4 |  |    |

**REVISION HISTORY**

**6/14—Rev. C to Rev. D**

Change to Adding Hysteresis Section..... 10

**8/13—Rev. B to Rev. C**

Changes to  $V_{IN\_HI}$  and  $V_{IN\_LO}$  Equations..... 9

**3/11—Rev. A to Rev. B**

Changes to Figure 19 Caption..... 9

Changes to Adding Hysteresis Section .....

Added Figure 21 and Figure 22, Renumbered Sequentially .....

Updated Outline Dimensions .....

**1/06—Rev. 0 to Rev. A**

Changes to Features..... 1

Changes to Figure 19..... 9

Changes to Figure 20 Caption..... 10

Updated Outline Dimensions .....

**10/04—Revision 0: Initial Version**

## SPECIFICATIONS

$V_{CC}$  = full operating range,  $T_A$  =  $-40^{\circ}\text{C}$  to  $+85^{\circ}\text{C}$ , unless otherwise noted.

Table 1.

| Parameter                          | Min          | Typ | Max      | Unit                           | Test Conditions/Comments                   |
|------------------------------------|--------------|-----|----------|--------------------------------|--|
| SUPPLY                             |              |     |          |                                |  |
| $V_{CC}$ Operating Voltage Range   | 2.25         |     | 5.5      | V                              |  |
| Supply Current                     |              | 4   | 7        | $\mu\text{A}$                  |  |
| COMMON-MODE INPUT RANGE            | 0            |     | $V_{CC}$ | V                              |  |
| INPUT OFFSET VOLTAGE               |              |     | 9        | mV                             | $V_{IN} = V_{CC} / 2$                      |
| INPUT OFFSET VOLTAGE AVERAGE DRIFT |              | 5   |          | $\mu\text{V}/^{\circ}\text{C}$ | $V_{CM} = 0\text{ V}$                      |
| INPUT BIAS CURRENT                 |              |     | 50       | nA                             | $V_{IN} = V_{CC} / 2$                      |
| INPUT OFFSET CURRENT               |              |     | 150      | nA                             | $V_{IN} = V_{CC} / 2$                      |
| OUT VOLTAGE LOW                    |              |     | 0.4      | V                              | $IN+ < IN-, I_{SINK} = 1.2\text{ mA}$      |
| OUT VOLTAGE HIGH (ADCMP371)        | $0.8 V_{CC}$ |     |          | V                              | $IN+ > IN-, I_{SOURCE} = 500\ \mu\text{A}$ |
| OUT LEAKAGE CURRENT (ADCMP370)     |              |     | 1        | $\mu\text{A}$                  | $IN+ > IN-, OUT = 22\text{ V}$             |
| Output Rise Time                   |              | 30  |          | ns                             | $C_{OUT} = 15\text{ pF}$                   |
| Output Fall Time                   |              | 45  |          | ns                             | $C_{OUT} = 15\text{ pF}$                   |
| TIMING                             |              |     |          |                                |  |
| Propagation Delay                  |              | 5   |          | $\mu\text{s}$                  | Input overdrive = 10 mV                    |
|                                    |              | 2   |          | $\mu\text{s}$                  | Input overdrive = 100 mV                   |

## ABSOLUTE MAXIMUM RATINGS

$T_A = 25^\circ\text{C}$ , unless otherwise noted.

**Table 2.**

| Parameter                             | Rating                     |
|---------------------------------------|----------------------------|
| $V_{CC}$                              | -0.3 V to +6 V             |
| IN+, IN-                              | -0.3 V to +25 V            |
| OUT (ADCMP370)                        | -0.3 V to +25 V            |
| OUT (ADCMP371)                        | -0.3 V to $V_{CC} + 0.3$ V |
| Operating Temperature Range           | -40°C to +85°C             |
| Storage Temperature Range             | -65°C to +150°C            |
| $\theta_{JA}$ Thermal Impedance, SC70 | 146°C/W                    |
| Lead Temperature                      |                            |
| Soldering (10 sec)                    | 300°C                      |
| Vapor Phase (60 sec)                  | 215°C                      |
| Infrared (15 sec)                     | 220°C                      |

Stresses above those listed under Absolute Maximum Ratings may cause permanent damage to the device. This is a stress rating only; functional operation of the device at these or any other conditions above those indicated in the operational section of this specification is not implied. Exposure to absolute maximum rating conditions for extended periods may affect device reliability.

### ESD CAUTION



**ESD (electrostatic discharge) sensitive device.** Charged devices and circuit boards can discharge without detection. Although this product features patented or proprietary protection circuitry, damage may occur on devices subjected to high energy ESD. Therefore, proper ESD precautions should be taken to avoid performance degradation or loss of functionality.

## PIN CONFIGURATION AND FUNCTION DESCRIPTIONS

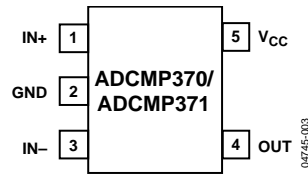

Figure 3. Pin Configuration

Table 3. Pin Function Descriptions

| Pin No. | Mnemonic        | Description   |
|---------|-----------------|---|
| 1       | IN+             | Noninverting Input.   |
| 2       | GND             | Ground.   |
| 3       | IN-             | Inverting Input.  |
| 4       | OUT             | Comparator Output. Open drain for <a href="#">ADCMP370</a> . Push-pull for <a href="#">ADCMP371</a> . |
| 5       | V <sub>CC</sub> | Power Supply.   |

TYPICAL PERFORMANCE CHARACTERISTICS

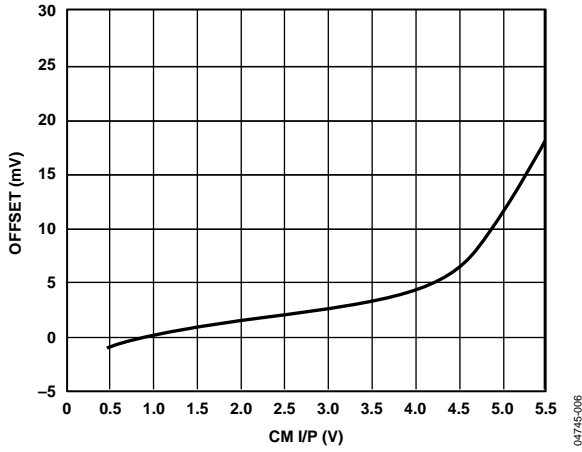

Figure 4. Input Offset vs. Common-Mode Input Voltage

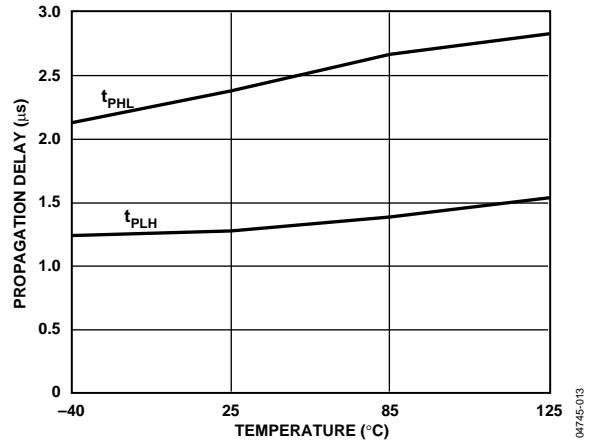

Figure 7. Propagation Delay vs. Temperature

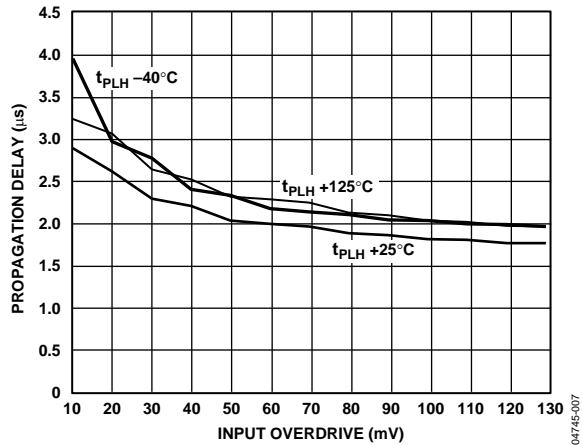

Figure 5. Propagation Delay vs. Input Overdrive (Low to High)

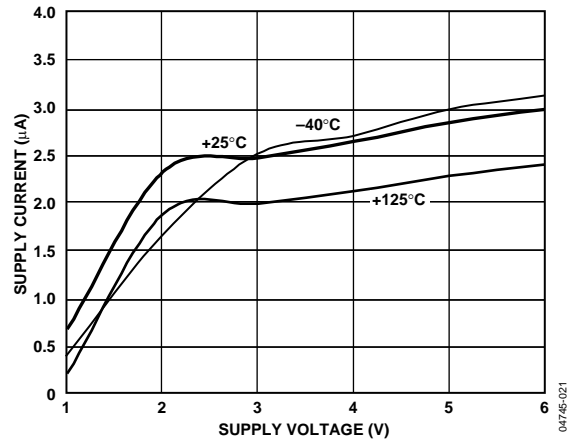

Figure 8. Supply Current vs. Supply Voltage (Output Low)

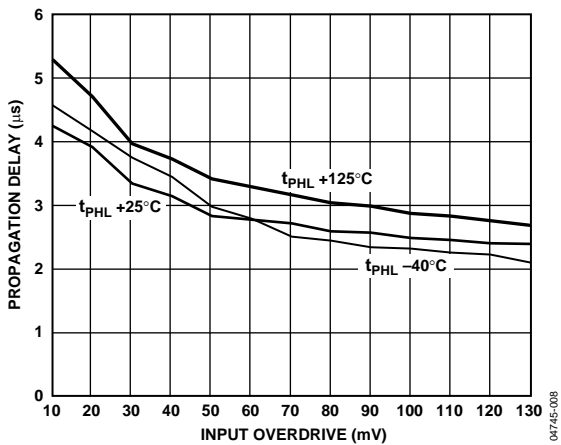

Figure 6. Propagation Delay vs. Input Overdrive (High to Low)

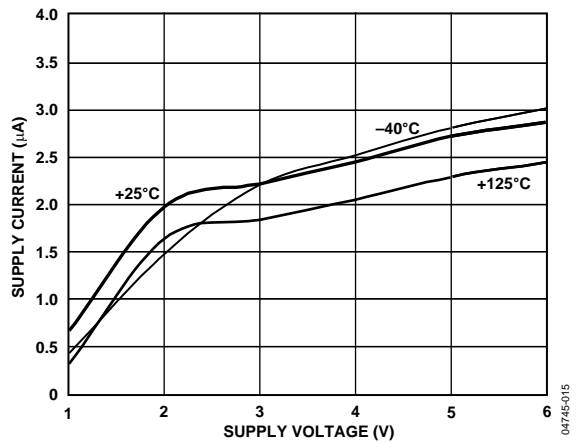

Figure 9. Supply Current vs. Supply Voltage (Output High)

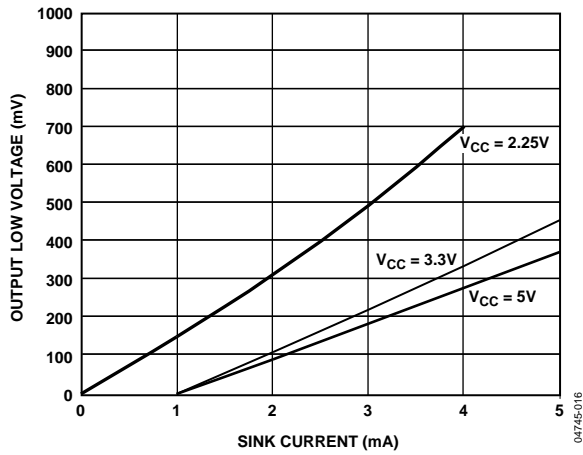

Figure 10. Output Low Voltage vs. Sink Current

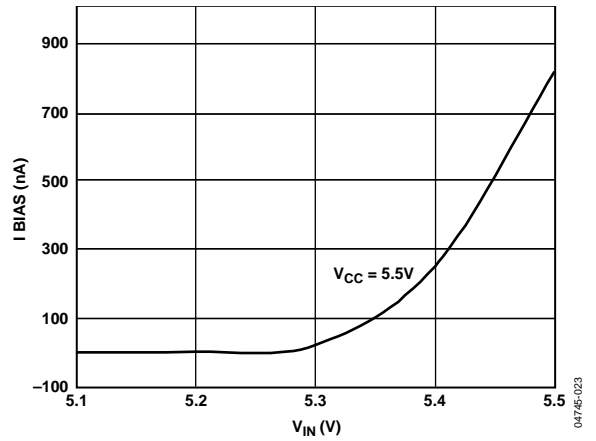

Figure 13. Input Bias Current vs. Input Voltage

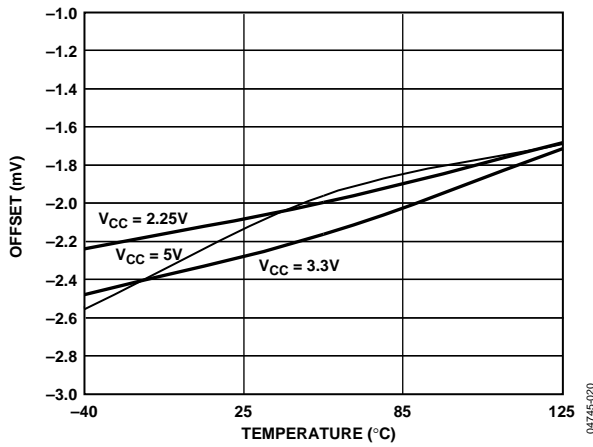

Figure 11. Input Offset vs. Temperature

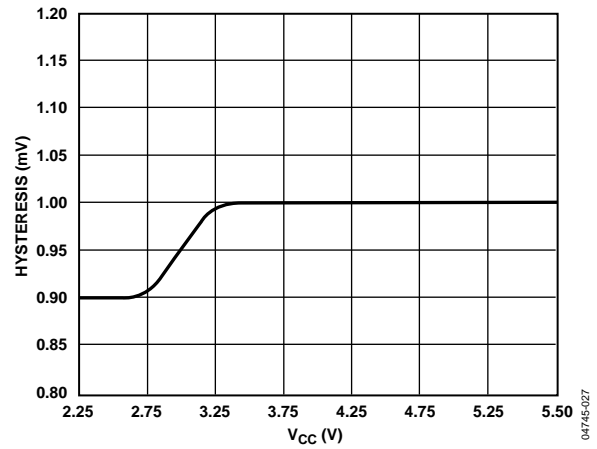

Figure 14. Hysteresis vs. Supply Voltage

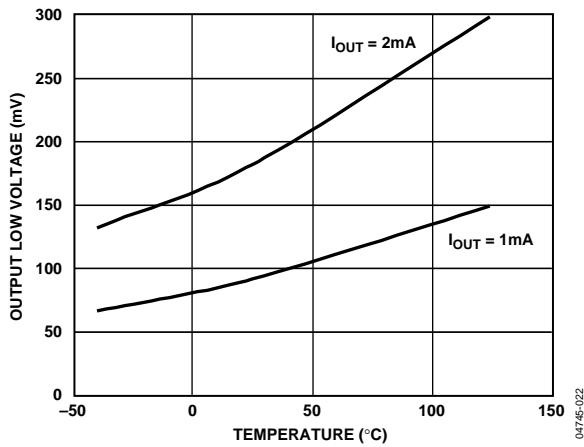

Figure 12. Output Low Voltage vs. Temperature

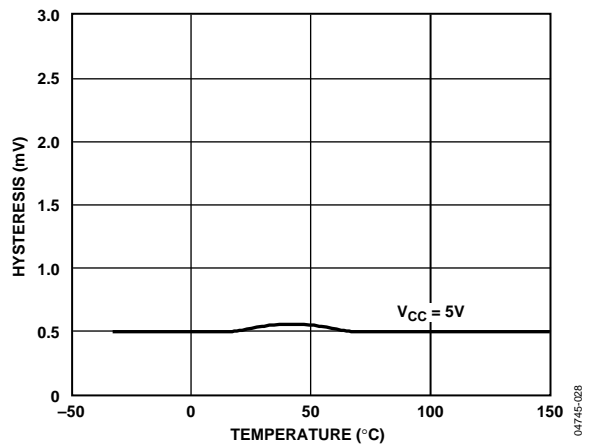

Figure 15. Hysteresis vs. Temperature

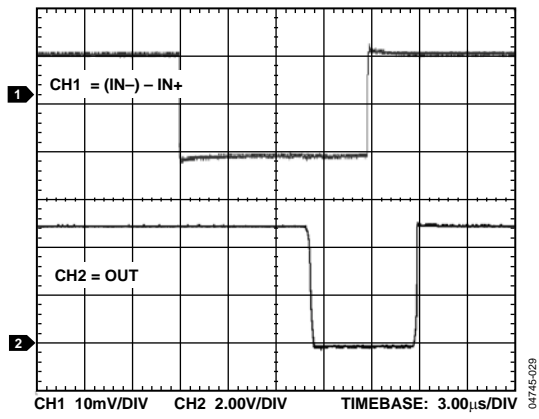

Figure 16. Propagation Delay Timing 10 mV Overdrive

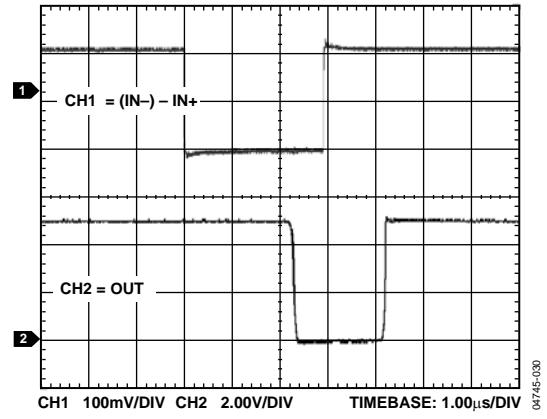

Figure 17. Propagation Delay Timing 100 mV Overdrive



## APPLICATIONS

### BASIC COMPARATOR

In its most basic configuration, a comparator can be used to convert an analog input signal to a digital output signal. The analog signal on IN+ is compared to the voltage on IN−, and the voltage at OUT is either high or low, depending on whether IN+ is at a higher or lower potential than IN−, respectively.

The ADCMP370 and ADCMP371 have different digital output structures. The ADCMP370 has an open-drain output stage that requires an external resistor to pull OUT to the logic high voltage level when the output transistor is switched off. This voltage level can be as high as 22 V. The same 22 V tolerance also applies to the inputs of the comparators. The pull-up resistor should be large enough to avoid excessive power dissipation but small enough to switch logic levels reasonably quickly when the comparator output is connected to other digital circuitry. A suitable value is between 1 kΩ and 10 kΩ. The ADCMP371 has a push-pull output stage, which has an internal PMOS pull-up and, therefore, does not require an external resistor. Faster switching speeds between low and high rails are possible, but the logic high level is limited to V<sub>CC</sub>.

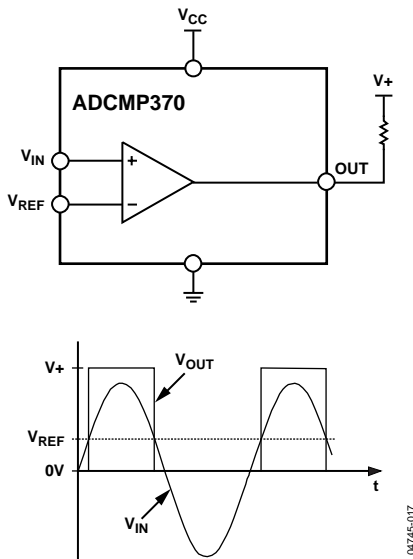

Figure 18. Basic Comparator and Input and Output Signals

### ADDING HYSTERESIS

To prevent oscillations at the output caused by noise or slowly moving signals passing the switching threshold, positive feedback can be used to add hysteresis to the differential input.

For the noninverting configuration, shown in Figure 19, two resistors are used to create different switching thresholds, depending on whether the input signal is increasing or decreasing in magnitude. When the input voltage is increasing, the threshold is above V<sub>REF</sub>, and when it is decreasing, the threshold is below V<sub>REF</sub>.

The upper input threshold level is given by

$$V_{IN\_HI} = \frac{V_{REF}(R1 + R2)}{R2}$$

The lower input threshold level is given by

$$V_{IN\_LO} = \frac{V_{REF}(R1 + R2) - V_{CC}R1}{R2}$$

The hysteresis is the difference between these voltage levels

$$\Delta V_{IN} = \frac{V_{CC}R1}{R2}$$

In the example in Figure 19, Resistor R1 and Resistor R2 are chosen to give 1 V hysteresis about the reference of 2.5 V, with V<sub>CC</sub> = 5 V.

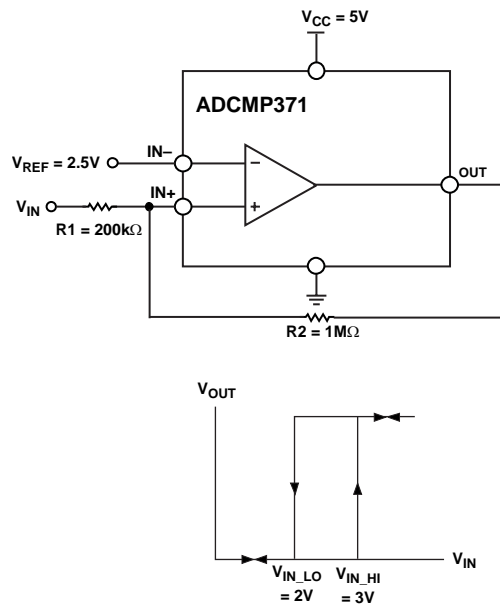

Figure 19. Noninverting ADCMP371 Comparator Configuration with Hysteresis

With the inverting configuration, the upper and lower switching thresholds are

$$V_{IN\_HI} = \frac{V_{CC}R2}{(R1 \parallel R3) + R2}$$

$$V_{IN\_HI} = \frac{V_{CC} \times R2(R1 + R3)}{(R1 \times R3) + (R2 \times R1) + (R2 \times R3)}$$

$$V_{IN\_LO} = \frac{V_{CC}(R2 \parallel R3)}{R1 + (R2 \parallel R3)}$$

$$V_{IN\_LO} = \frac{V_{CC} \times R2 \times R3}{(R1 \times R3) + (R2 \times R1) + (R2 \times R3)}$$

The hysteresis is the difference between these voltage levels and is given by

$$\Delta V_{IN} = \frac{V_{CC} \times R1 \times R2}{(R1 \times R3) + (R2 \times R1) + (R2 \times R3)}$$

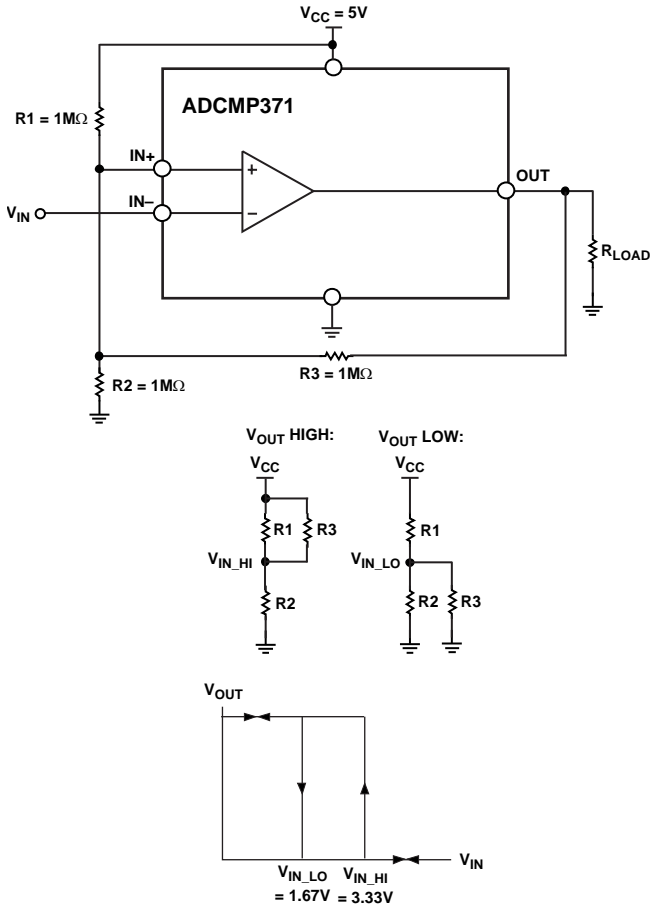

Figure 20. Inverting ADCMP371 Comparator Configuration with Hysteresis

For the ADCMP370 configuration, a pull-up resistor is required for the open-drain output, which affects the hysteresis calculation. The noninverting ADCMP370 configuration is shown in Figure 21. The upper switching threshold is

$$V_{IN\_HI} = \frac{V_{REF}(R1 + R2)}{R2}$$

The lower input threshold level is given by

$$V_{IN\_LO} = \frac{V_{REF}(R1 + R2 + R_{PULLUP}) - V_{CC}R1}{R2 + R_{PULLUP}}$$

The hysteresis is the difference between these voltage levels

$$\Delta V_{IN} = \frac{V_{CC}R1}{R2 + R_{PULLUP}}$$

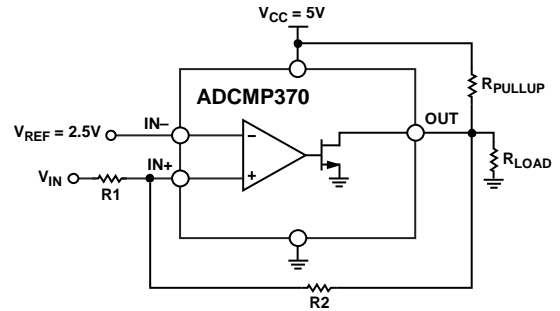

Figure 21. Noninverting ADCMP370 Comparator Configuration with Hysteresis

The inverting ADCMP370 configuration is shown in Figure 22. The upper and lower switching thresholds are

$$V_{IN\_HI} = \frac{V_{CC}R2}{(R1 \parallel (R3 + R_{PULLUP})) + R2}$$

$$V_{IN\_HI} = \frac{V_{CC} \times R2(R1 + (R3 + R_{PULLUP}))}{(R1 \times (R3 + R_{PULLUP})) + (R2 \times R1) + (R2 \times (R3 + R_{PULLUP}))}$$

$$V_{IN\_LO} = \frac{V_{CC}(R2 \parallel (R3 + R_{PULLUP}))}{R1 + (R2 \parallel (R3 + R_{PULLUP}))}$$

$$V_{IN\_LO} = \frac{V_{CC} \times R2 \times (R3 + R_{PULLUP})}{(R1 \times (R3 + R_{PULLUP})) + (R2 \times R1) + (R2 \times (R3 + R_{PULLUP}))}$$

assuming  $R_{LOAD} \gg R1, R2, R3, R_{PULLUP}$ .

The hysteresis is the difference between these voltage levels and is given by

$$\Delta V_{IN} = \frac{V_{CC} \times R1 \times R2}{(R1 \times (R3 + R_{PULLUP})) + (R2 \times R1) + (R2 \times (R3 + R_{PULLUP}))}$$

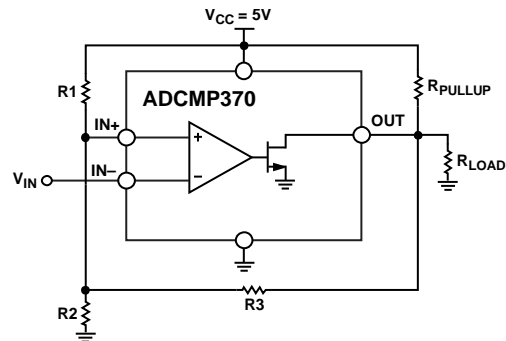
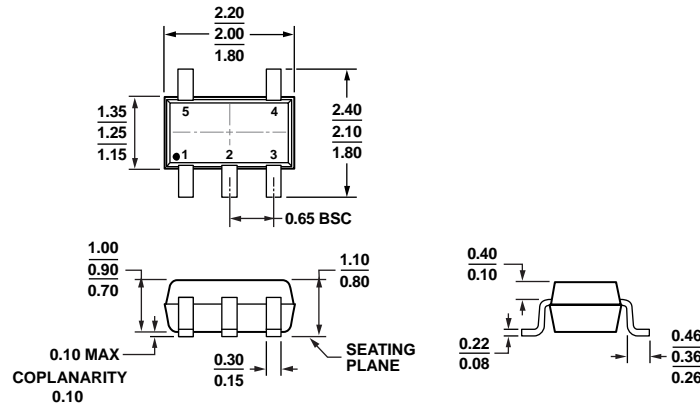

Figure 22. Inverting ADCMP370 Comparator Configuration with Hysteresis

### OUTLINE DIMENSIONS



COMPLIANT TO JEDEC STANDARDS MO-203-AA

Figure 23. 5-Lead Thin Shrink Small Outline Transistor Package [SC70] (KS-5)

Dimensions shown in millimeters

072019-A

### ORDERING GUIDE

| Model <sup>1</sup> | Temperature Range | Package Description | Package Option | Branding |
|--------------------|-------------------|---------------------|----------------|----------|
| ADCMP370AKS-REEL   | -40°C to +85°C    | 5-Lead SC70         | KS-5           | M1F      |
| ADCMP370AKS-REEL7  | -40°C to +85°C    | 5-Lead SC70         | KS-5           | M1F      |
| ADCMP370AKSZ-REEL  | -40°C to +85°C    | 5-Lead SC70         | KS-5           | M8P      |
| ADCMP370AKSZ-REEL7 | -40°C to +85°C    | 5-Lead SC70         | KS-5           | M8P      |
| ADCMP371AKS-REEL   | -40°C to +85°C    | 5-Lead SC70         | KS-5           | M1G      |
| ADCMP371AKS-REEL7  | -40°C to +85°C    | 5-Lead SC70         | KS-5           | M1G      |
| ADCMP371AKSZ-REEL7 | -40°C to +85°C    | 5-Lead SC70         | KS-5           | M8W      |

<sup>1</sup> Z = RoHS Compliant Part.

**NOTES**

Компания «Life Electronics» занимается поставками электронных компонентов импортного и отечественного производства от производителей и со складов крупных дистрибьюторов Европы, Америки и Азии.

С конца 2013 года компания активно расширяет линейку поставок компонентов по направлению коаксиальный кабель, кварцевые генераторы и конденсаторы (керамические, пленочные, электролитические), за счёт заключения дистрибьюторских договоров

Мы предлагаем:

- Конкурентоспособные цены и скидки постоянным клиентам.
- Специальные условия для постоянных клиентов.
- Подбор аналогов.
- Поставку компонентов в любых объемах, удовлетворяющих вашим потребностям.
- Приемлемые сроки поставки, возможна ускоренная поставка.
- Доставку товара в любую точку России и стран СНГ.
- Комплексную поставку.
- Работу по проектам и поставку образцов.
- Формирование склада под заказчика.
- Сертификаты соответствия на поставляемую продукцию (по желанию клиента).
- Тестирование поставляемой продукции.
- Поставку компонентов, требующих военную и космическую приемку.
- Входной контроль качества.
- Наличие сертификата ISO.

В составе нашей компании организован Конструкторский отдел, призванный помогать разработчикам, и инженерам.

Конструкторский отдел помогает осуществить:

- Регистрацию проекта у производителя компонентов.
- Техническую поддержку проекта.
- Защиту от снятия компонента с производства.
- Оценку стоимости проекта по компонентам.
- Изготовление тестовой платы монтаж и пусконаладочные работы.



Тел: +7 (812) 336 43 04 (многоканальный)  
Email: [org@lifeelectronics.ru](mailto:org@lifeelectronics.ru)