

S1D13A05 LCD/USB Companion Chip

February 2009

The S1D13A05 is an LCD/USB solution designed for seamless connection to a wide variety of microprocessors. The S1D13A05 integrates a USB slave controller and an LCD graphics controller with an embedded 256K byte SRAM display buffer. The LCD controller supports all standard panel types and multiple TFT types eliminating the need for an external timing control IC. The S1D13A05 includes a Hardware Acceleration Engine to greatly improve screen drawing functions and the built-in USB controller provides revision 1.1 compliance for applications requiring a USB client. This high level of integration provides a low cost, low power, single chip solution to meet the demands of embedded markets requiring USB client support, such as Mobile Communications devices and Palm-size PCs.

The S1D13A05 utilizes a guaranteed low-latency CPU architecture that provides support for microprocessors without READY/WAIT# handshaking signals. The 32-bit internal data path, write buffer and the Hardware Acceleration Engine provide high performance bandwidth into display memory allowing for fast display updates.

Additionally, products requiring a rotated display can take advantage of the SwivelView™ feature which provides hardware rotation of the display memory transparent to the software application. The S1D13A05 also provides support for “Picture-in-Picture Plus” (a variable size Overlay window).

The S1D13A05, with its integrated USB client, provides impressive support for Palm OS® handhelds. However, its impartiality to CPU type or operating system makes it an ideal display solution for a wide variety of applications.

■ FEATURES

- Embedded 256KB Display Buffer.
- Low Operating Voltage.
- Low-latency CPU interface.
- Direct support for multiple CPU types.
- Programmable resolutions and color depths.
- Passive LCD support.
- Active Matrix LCD support.
- Extended TFT interfaces (Type 2, 3, 4).
- ‘Direct’ Sharp HR-TFT support (including Mode 2).
- ‘Direct’ Casio TFT support.
- USB Client, Revision 1.1 compliant.
- SwivelView™ (90°, 180°, 270° hardware rotation of displayed image).
 - (Patent # 5,734,875 - Patent # 5,956,049 - Patent #6,262,751)
- “Picture-in-Picture Plus”.
- Pixel Doubling.
- Hardware Acceleration Engine.
- Software Initiated Power Save Mode.
- 48MHz crystal for USBCLK.
- Software Video Invert.
- 121-pin PFBGA and 128-pin QFP5 packages.



■ SYSTEM BLOCK DIAGRAM

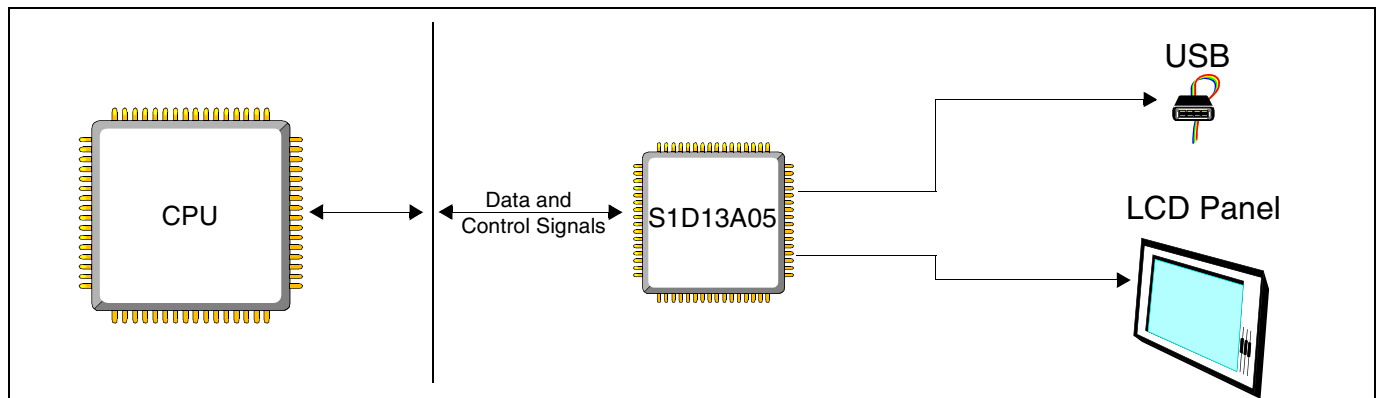

S1D13A05

DESCRIPTION

Memory Interface

- Embedded 256K byte SRAM display buffer.

CPU Interface

- 'Fixed' low-latency CPU access times.
- Direct support for:
 - Hitachi SH-4 / SH-3.
 - Motorola M68xxx (REDCAP2, DragonBall, ColdFire).
 - Motorola Dragonball SZ support (66MHz)
 - MPU bus interface with programmable READY.

Integrated USB Features

- USB Client, Revision 1.1 Compliant.

Power Down Modes

- Software Initiated Power Save Mode.

Operating Voltage

- $CORE_{VDD}$ 2.0 ± 10% volts or 2.5 ± 10% volts.
- IO_{VDD} 3.3 ± 10% volts.

Clock Source

- Three independent clock inputs including dedicated USB clock (single clock possible if USB not required).
- 48MHz crystal oscillator for USBCLK.

Package

- 121-pin PFBGA
- 128-pin QFP5

Integrated LCD Controller Features

- 1/2/4/8/16 bit-per-pixel (bpp) support.
- Up to 64 gray shades on monochrome passive panels.
- Up to 64K colors on passive/active matrix panels.
- Single-panel, single-drive passive displays.
 - 4/8-bit monochrome and 4/8/16-bit color interfaces.
- 9/12/18-bit Active matrix TFT interface.
- 'Direct support for multiple TFT interfaces (Epson, Sharp, Type 2, 3, 4, external timing IC not required).
- SwivelView: hardware rotation by 90°, 180°, 270°.
- "Picture-in-Picture Plus": displays a variable size window overlaid over background image.
- Pixel Doubling: horizontal and vertical resolutions can be doubled without any additional memory.
- Software video invert.
- Typical resolutions supported:
 - 320x320 @ 16bpp
 - 160x160 @ 16bpp (2 pages)
 - 160x240 @ 16bpp
- 2D BitBLT Engine.

Write BLT	Transparent Write BLT
Move BLT	Transparent Move BLT
Solid Fill BLT	Read BLT
Pattern Fill	Color Expansion BLT
Move BLT with Color Expansion	

CONTACT YOUR SALES REPRESENTATIVE FOR THESE COMPREHENSIVE DESIGN TOOLS

- S1D13A05 Technical Manual
- Palm OS® Hardware Abstraction Layer
- S5U13A05 Evaluation Boards
- Windows® CE Display Driver
- CPU Independent Software Utilities
- VXWorks® Tornado™ Display Driver

Japan

Seiko Epson Corporation
 IC International Sales Group
 421-8, Hino, Hino-shi
 Tokyo 191-8501, Japan
 Tel: 042-587-5812
 Fax: 042-587-5564
<http://www.epson.co.jp/>

Hong Kong

Epson Hong Kong Ltd.
 20/F., Harbour Centre
 25 Harbour Road
 Wanchai, Hong Kong
 Tel: 2585-4600
 Fax: 2827-4346
<http://www.epson.com.hk/>

North America

Epson Electronics America, Inc.
 2580 Orchard Parkway
 San Jose, CA 95131, USA
 Tel: (408) 922-0200
 Fax: (408) 922-0238
<http://www.eea.epson.com/>

Europe

Epson Europe Electronics GmbH
 Riesstrasse 15
 80992 Munich, Germany
 Tel: 089-14005-0
 Fax: 089-14005-110
<http://www.epson-electronics.de/>

Taiwan

Epson Taiwan Technology & Trading Ltd.
 14F, No. 7
 Song Ren Road
 Taipei 110
 Tel: 02-8786-6688
 Fax: 02-8786-6677
<http://www.epson.com.tw/>

Singapore

Epson Singapore Pte Ltd
 1 HarbourFront Place #03-02
 HarbourFront Tower One
 Singapore, 098633
 Tel: (65) 6586-5500
 Fax: (65) 6271-3182
<http://www.epson.com.sg/>

© SEIKO EPSON CORPORATION 2001-2008. All rights reserved.
 Information in this document is subject to change without notice. You may download and use this document, but only for your own use in evaluating Seiko Epson/EPSON products. You may not modify the document. Epson Research and Development, Inc. disclaims any representation that the contents of this document are accurate or current. The Programs/Technologies described in this document may contain material protected under U.S. and/or International Patent laws. EPSON is a registered trademark of Seiko Epson Corporation. Palm Computing is a registered trademark and the Palm OS platform Platinum logo is a trademark of Palm Computing, Inc., 3Com or its subsidiaries. Microsoft, Windows, and the Windows Embedded Partner Logo are registered trademarks of Microsoft Corporation. All other trademarks are the property of their respective owners.

Компания «Life Electronics» занимается поставками электронных компонентов импортного и отечественного производства от производителей и со складов крупных дистрибьюторов Европы, Америки и Азии.

С конца 2013 года компания активно расширяет линейку поставок компонентов по направлению коаксиальный кабель, кварцевые генераторы и конденсаторы (керамические, пленочные, электролитические), за счёт заключения дистрибьюторских договоров

Мы предлагаем:

- Конкурентоспособные цены и скидки постоянным клиентам.
- Специальные условия для постоянных клиентов.
- Подбор аналогов.
- Поставку компонентов в любых объемах, удовлетворяющих вашим потребностям.
- Приемлемые сроки поставки, возможна ускоренная поставка.
- Доставку товара в любую точку России и стран СНГ.
- Комплексную поставку.
- Работу по проектам и поставку образцов.
- Формирование склада под заказчика.
- Сертификаты соответствия на поставляемую продукцию (по желанию клиента).
- Тестирование поставляемой продукции.
- Поставку компонентов, требующих военную и космическую приемку.
- Входной контроль качества.
- Наличие сертификата ISO.

В составе нашей компании организован Конструкторский отдел, призванный помогать разработчикам, и инженерам.

Конструкторский отдел помогает осуществить:

- Регистрацию проекта у производителя компонентов.
- Техническую поддержку проекта.
- Защиту от снятия компонента с производства.
- Оценку стоимости проекта по компонентам.
- Изготовление тестовой платы монтаж и пусконаладочные работы.



Тел: +7 (812) 336 43 04 (многоканальный)

Email: org@lifeelectronics.ru