

Description

SE555Q is precision timing circuit capable of producing accurate time delays or oscillation. In the time-delay or monostable mode of operation, the timed interval is controlled by a single external resistor and capacitor network. In the astable mode of operation, the frequency and duty cycle can be controlled independently with two external resistors and a single external capacitor.

The threshold and trigger levels normally are two-thirds and one-third, respectively, of V_{CC} . These levels can be altered by use of the control-voltage terminal. When the trigger input falls below the trigger level, the flip-flop is set, and the output goes high. If the trigger input is above the trigger level and the threshold input is above the threshold level, the flip-flop is reset and the output is low. The reset (RESET) input can override all other inputs and can be used to initiate a new timing cycle. When RESET goes low, the flip-flop is reset, and the output goes low. When the output is low, a low-impedance path is provided between discharge (DISCH) and ground.

The output circuit is capable of sinking or sourcing current up to 200mA. Operation is specified for supplies of 5V to 15V. With a 5V supply, output levels are compatible with TTL inputs.

Features

- Timing from Microseconds to Hours
- Astable or Monostable Operation
- Adjustable Duty Cycle
- TTL Compatible Output Can Source or Sink up to 200mA
- Automotive Grade
 - Qualified to AEC-Q100 Grade 1
- "Green" Molding Compound (No Br, Sb)
- **Totally Lead-Free & Fully RoHS Compliant (Notes 1 & 2)**
- **Halogen and Antimony Free. "Green" Device (Note 3)**
- **PPAP Capable (Note 4)**

- Notes:
1. No purposely added lead. Fully EU Directive 2002/95/EC (RoHS) & 2011/65/EU (RoHS 2) compliant.
 2. See http://www.diodes.com/quality/lead_free.html for more information about Diodes Incorporated's definitions of Halogen- and Antimony-free, "Green" and Lead-free.
 3. Halogen- and Antimony-free "Green" products are defined as those which contain <900ppm bromine, <900ppm chlorine (<1500ppm total Br + Cl) and <1000ppm antimony compounds.
 4. Automotive products are AEC-Q100 qualified and are PPAP capable. Refer to http://www.diodes.com/product_compliance_definitions.html.

Pin Assignments

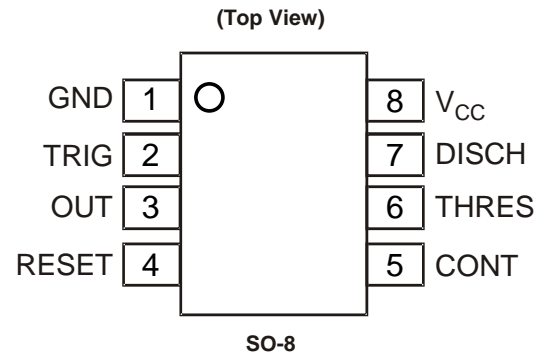

Pin Descriptions

Pin Number	Pin Name	Description
1	GND	Ground
2	TRIG	Trigger set $1/3V_{CC}$
3	OUT	Timer output
4	RESET	Reset active low
5	CONT	External adjustment of internal threshold and trigger voltages
6	THRES	Threshold set to $2/3 V_{CC}$
7	DISCH	Low impedance discharge path
8	V _{CC}	Chip supply voltage

Functional Block Diagram

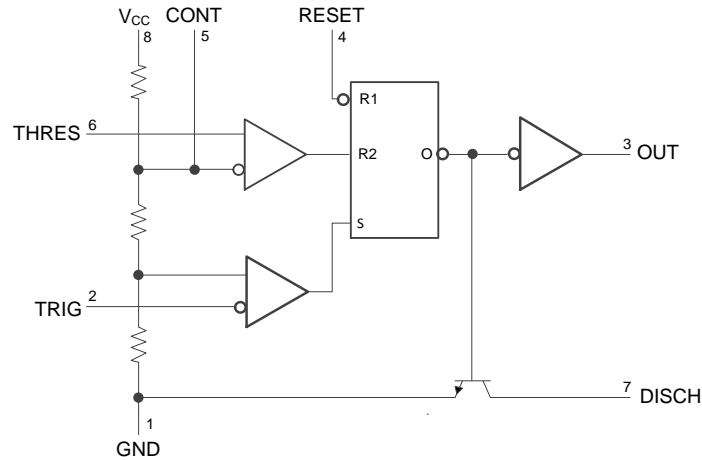

RESET can override TRIG, which can override THRESH

Functional Table

Pin Name	Nominal Trigger Voltage	Threshold Voltage	Output	Discharge Switch
GND	Irrelevant	Irrelevant	Low	On
TRIG	$<1/3V_{CC}$	Irrelevant	High	Off
OUT	$<1/3V_{CC}$	$<2/3V_{CC}$	Low	On
RESET	$<1/3V_{CC}$	$<2/3V_{CC}$	As previously established	

Absolute Maximum Ratings (Note 5) (@ $T_A = +25^\circ\text{C}$, unless otherwise stated.)

Symbol	Parameter	Rating	Unit
V_{CC}	Supply Voltage (Note 6)	18	V
V_I	Input Voltage	CONT, RESET, THRES, TRIG	V_{CC}
I_O	Output Current	± 225	mA
θ_{JA}	Package Thermal Resistance Junction-to-Ambient (Note 7)	130	$^\circ\text{C/W}$
θ_{JC}	Package Thermal Resistance Junction-to-Case (Note 8)	15	$^\circ\text{C/W}$
T_J	Junction Temperature	+150	$^\circ\text{C}$
T_{STG}	Storage Temperature	-65 to +150	$^\circ\text{C}$

- Notes:
- Stresses beyond those listed under "absolute maximum ratings" may cause permanent damage to the device. These are stress ratings only. Functional operation of the device at these or any other conditions beyond those indicated under "recommended operating conditions" is not implied. Exposure to absolute-maximum-rated conditions for extended periods may affect device reliability.
 - All voltage values are with respect ground.
 - Maximum power dissipation is a function of $T_J(\text{max})$, θ_{JA} , and T_A . The maximum allowable power dissipation at any allowable ambient temperature is $P_D = (T_J(\text{max}) - T_A)/\theta_{JA}$. Operating at the absolute maximum T_J of +150 $^\circ\text{C}$ can affect reliability.
 - Maximum power dissipation is a function of $T_J(\text{max})$, θ_{JC} , and T_A . The maximum allowable power dissipation at any allowable ambient temperature is $P_D = (T_J(\text{max}) - T_C)/\theta_{JA}$. Operating at the absolute maximum T_J of +150 $^\circ\text{C}$ can affect reliability.

Recommended Operating Conditions ($T_A = +25^\circ\text{C}$)

Symbol	Parameter	Min	Max	Unit
V_{CC}	Supply Voltage	4.5	15	V
V_I	Input Voltage	CONT, RESET, THRES, TRIG	V_{CC}	V
I_O	Output Current	—	± 200	mA
T_A	Operating Ambient Temperature	-40	+125	$^\circ\text{C}$

Electrical Characteristics ($V_{CC} = 5\text{V}$ to 15V , $T_A = +25^\circ\text{C}$, unless otherwise stated.)

Symbol	Parameter	Test conditions	Min	Typ	Max	Unit
V_{TH}	Threshold Voltage Level	$V_{CC} = 15\text{V}$	8.8	10	11.2	V
		$V_{CC} = 5\text{V}$	2.4	3.3	4.2	
I_{TH}	Threshold Current (Note 9)	—	—	30	250	nA
V_{TR}	Trigger Voltage Level	$V_{CC} = 15\text{V}$	4.5	5	5.6	V
		$V_{CC} = 5\text{V}$	1.1	1.67	2.2	
I_{TR}	Trigger Current	TRIG at 0V	—	0.5	2	μA
V_{RST}	RESET Voltage Level	—	0.3	0.7	1	V
I_{RST}	RESET Current	RESET at V_{CC}	—	0.1	0.4	mA
		RESET at 0V	—	-0.4	-1.5	
I_{DIS}	DISCH Switch Off-state Current	—	—	20	100	nA
V_{DIS}	DISCH Saturation Voltage with Output Low (Note 10)	$V_{CC} = 15\text{V}$, $I_{DIS} = 15\text{mA}$	—	180	480	mV
		$V_{CC} = 5\text{V}$, $I_{DIS} = 4.5\text{mA}$	—	80	200	
V_{CON}	CONT Voltage (Open Circuit)	$V_{CC} = 15\text{V}$	9	10	11	V
		$V_{CC} = 5\text{V}$	2.6	3.3	4	

Electrical Characteristics (Cont. $V_{CC} = 5V$ to $15V$, $T_A = +25^\circ C$, unless otherwise stated.)

Symbol	Parameter	Test conditions	Min	Typ.	Max	Unit	
V_{OL}	Low Level Output Voltage	$V_{CC} = 15V, I_{OL} = 10mA$	—	0.1	0.25	V	
		$V_{CC} = 15V, I_{OL} = 50mA$	—	0.4	0.75		
		$V_{CC} = 15V, I_{OL} = 100mA$	—	2	2.5		
		$V_{CC} = 15V, I_{OL} = 200mA$	—	2.5	—		
		$V_{CC} = 5V, I_{OL} = 5mA$	—	0.1	0.35		
		$V_{CC} = 5V, I_{OL} = 8mA$	—	0.15	0.4		
V_{OH}	High Level Output Voltage	$V_{CC} = 15V, I_{OH} = -100mA$	12.75	13.3	—	V	
		$V_{CC} = 15V, I_{OH} = -200mA$	—	12.5	—		
		$V_{CC} = 5V, I_{OH} = -100mA$	2.75	3.3	—		
I_{CC}	Supply Current	Output low, no load	$V_{CC} = 15V$	—	10	15	mA
			$V_{CC} = 5V$	—	3	6	
		Output high, no load	$V_{CC} = 15V$	—	9	13	
			$V_{CC} = 5V$	—	2	5	
T_{ER}	Initial Error of Timing Interval (Note 11)	Each time, monostable (Note 12)	—	1	3	%	
		Each time, astable (Note 13)	—	2.25	—		
T_{TC}	Temperature Coefficient of Timing Interval	Each time, monostable (Note 12)	$T_A = \text{full range}$	—	50	—	ppm/ $^\circ C$
		Each time, astable (Note 13)		—	150	—	
T_{VCC}	Supply Voltage Sensitivity of Timing Interval	Each time, monostable (Note 12)	—	0.1	0.5	%/ V	
		Each time, astable (Note 13)	—	0.3	—		
t_{RI}	Output Pulse Rise Time	$C_L = 15pF$	—	100	300	ns	
t_{FA}	Output Pulse Fall Time	$C_L = 15pF$	—	100	300	ns	

- Notes:
9. This parameter influences the maximum value of the timing resistors R_A and R_B in the circuit of Figure 12. For example, when $V_{CC} = 5V$, the maximum value is $R = R_A + R_B \approx 3.4M\Omega$, and for $V_{CC} = 15V$, the maximum value is $10M\Omega$.
 10. No protection against excessive pin 7 current is necessary providing package dissipation rating is not exceeded.
 11. Timing interval error is defined as the difference between the measured value and the average value of a random sample from each process run.
 12. Values specified are for a device in a monostable circuit similar to Figure 9, with the following component values: $R_A = 2k\Omega$ to $100k\Omega$, $C = 0.1\mu F$.
 13. Values specified are for a device in an astable circuit similar to Figure 12, with the following component values: $R_A = 1k\Omega$ to $100k\Omega$, $C = 0.1\mu F$.

Typical Performance Characteristics

Low Level Output Voltage vs. Low Level Output Current @ $V_{CC} = 5V$

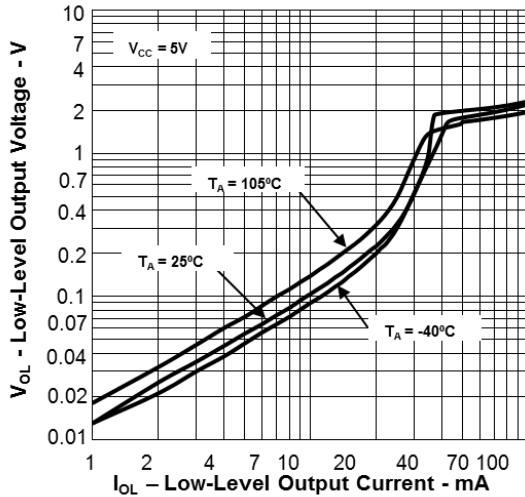

Low Level Output Voltage vs. Low Level Output Current @ $V_{CC} = 10V$

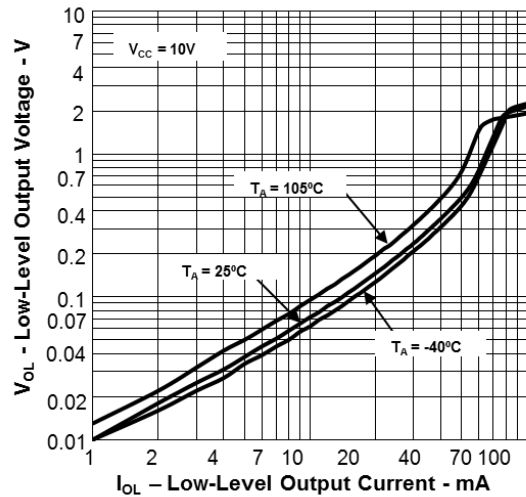

Low Level Output Voltage vs. Low Level Output Current @ $V_{CC} = 15V$

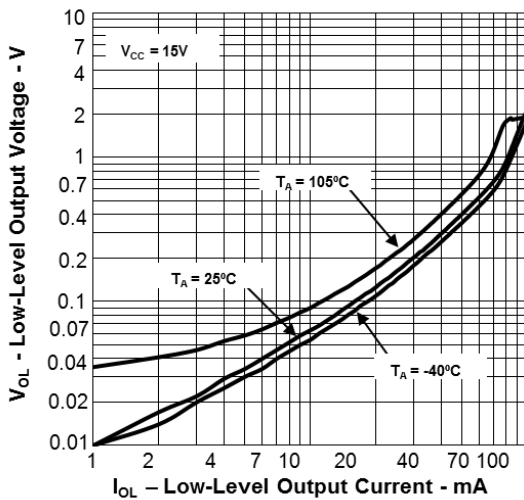

Drop Between Supply Voltage and Output vs. High Level Output Current

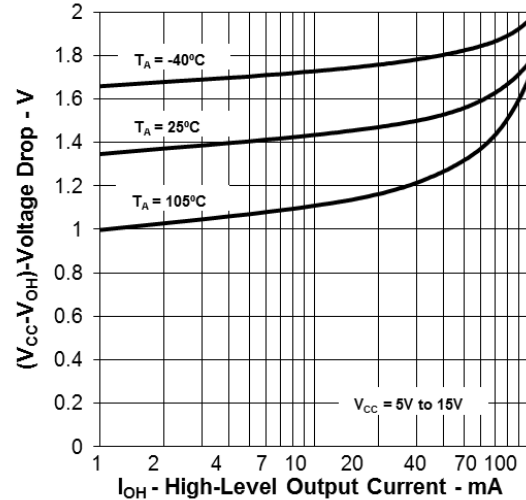

Supply Current vs. Supply Voltage

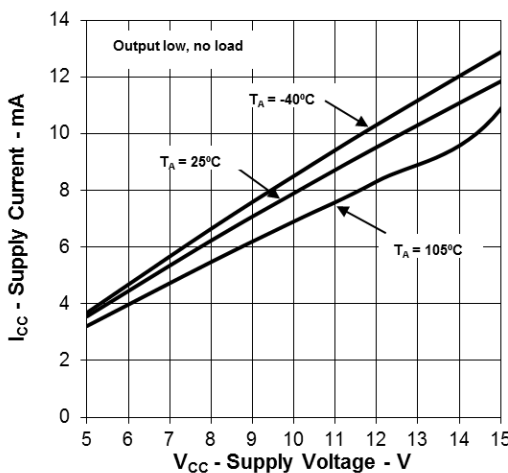

Propagation Delay Time vs. Lowest Voltage Level of Trigger Pulse

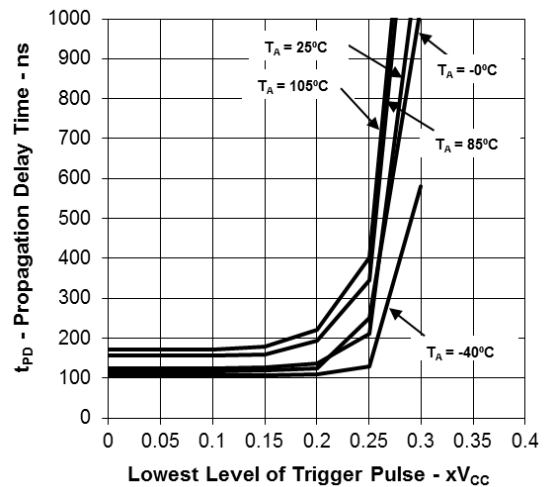

Typical Performance Characteristics (Cont.)

**Normalized Output Pulse Duration
(Monostable Mode) vs. Supply Voltage**

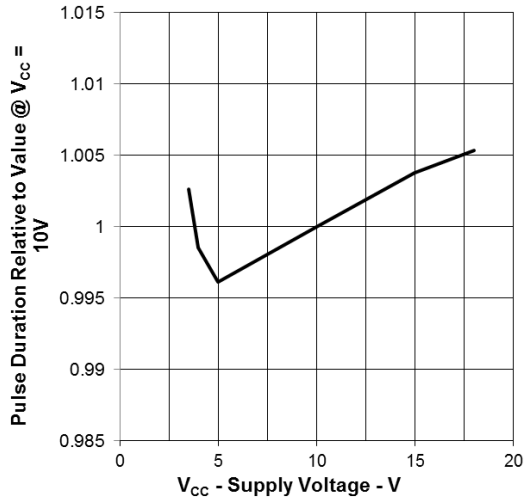

**Normalized Output Pulse Duration
(Monostable Mode) vs. Free-Air Temperature**

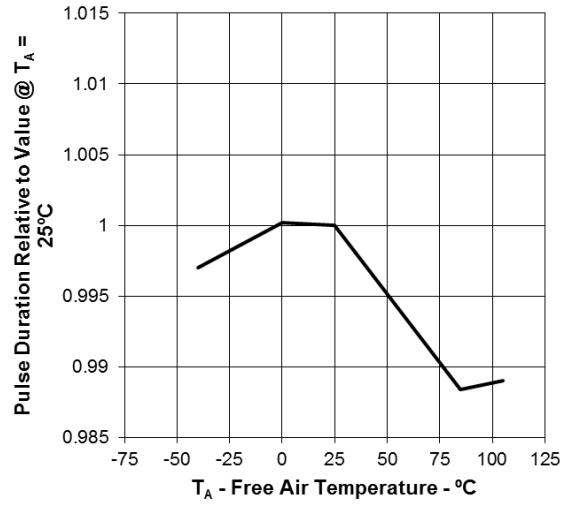

Typical Applications Characteristics

Monostable Operation

For monostable operation, any of the '555 timers can be connected as shown in Figure 1. If the output is low, application of a negative-going pulse to the trigger (TRIG) sets the internal flip-flop and drives the output high. Capacitor C is then charged through R_A until the voltage across the capacitor reaches the threshold voltage of the threshold (THRES) input. If TRIG has returned to a high level, the output of the threshold comparator resets the internal flip-flop, drives the output low, and discharges C.

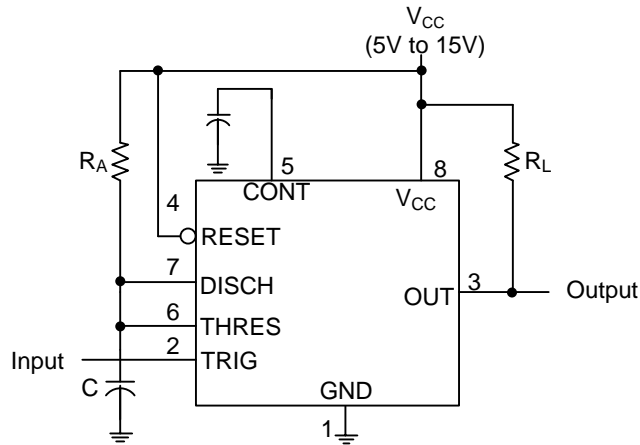

Figure 1. Monostable Operation

Monostable operation is initiated when TRIG voltage falls below the trigger threshold. Once initiated, the sequence ends only if TRIG is high for at least $10\mu\text{s}$ before the end of the timing interval. When the trigger is grounded, the comparator storage time can be as long as $10\mu\text{s}$, which limits the minimum monostable pulse width to $10\mu\text{s}$. Because of the threshold level and saturation voltage of Q1, the output pulse duration is approximately $t_W = 1.1R_A C$. Figure 3 is a plot of the time constant for various values of R_A and C. The threshold levels and charge rates both are directly proportional to the supply voltage, V_{CC} . The timing interval is, therefore, independent of the supply voltage, so long as the supply voltage is constant during the time interval.

Applying a negative-going trigger pulse simultaneously to RESET and TRIG during the timing interval discharges C and reinitiates the cycle, commencing on the positive edge of the reset pulse. The output is held low as long as the reset pulse is low. To prevent false triggering, when RESET is not used, it should be connected to V_{CC} .

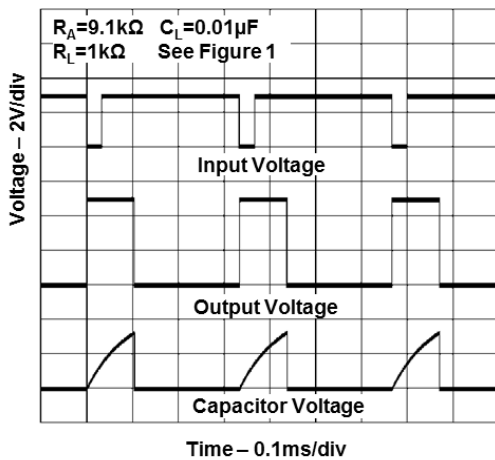

Figure 2. Typical Monostable Waveforms

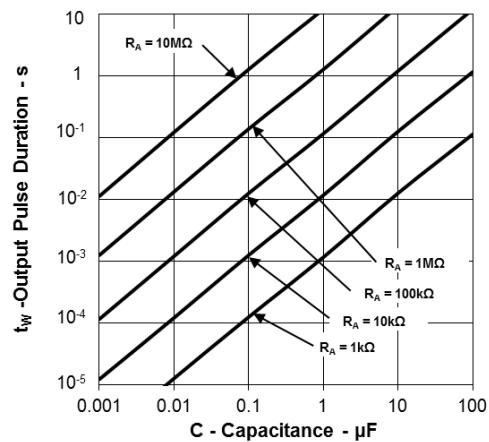

Figure 3. Output Pulse Duration vs. Capacitance

Typical Applications Characteristics (Cont.)

Astable Operation

As shown in Figure 4, adding a second resistor, R_B , to the circuit of Figure 1 and connecting the trigger input to the threshold input causes the timer to self-trigger and run as a multivibrator. The capacitor C charges through R_A and R_B and then discharges through R_B . Therefore, the duty cycle is controlled by the values of R_A and R_B .

This astable connection results in capacitor C charging and discharging between the threshold-voltage level ($\approx 0.67V_{CC}$) and the trigger-voltage level ($\approx 0.33V_{CC}$). As in the monostable circuit, charge and discharge time (and, therefore, the frequency and duty cycle) are independent of the supply voltage.

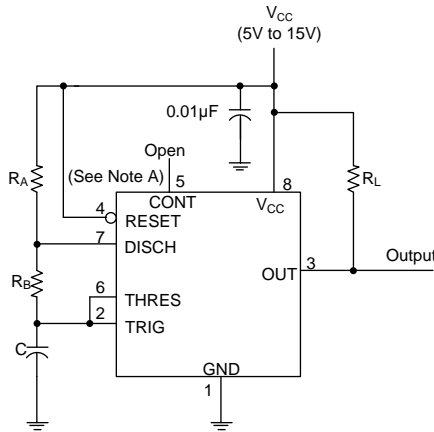

Decoupling CONT voltage to ground with a capacitor can improve operation. This should be evaluated for individual applications.

Figure 4. Circuit for Astable Operation

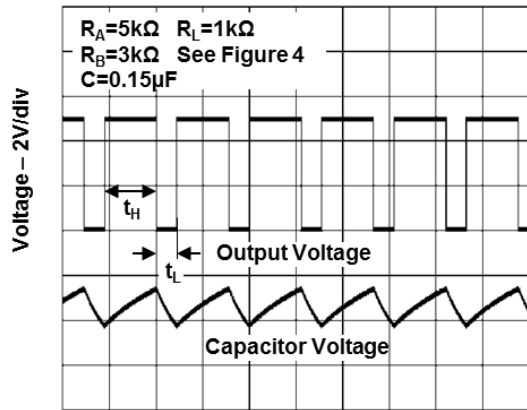

Figure 5. Typical Astable Waveforms

Figure 5 shows typical waveforms generated during astable operation. The output high-level duration t_H and low-level duration t_L can be calculated as follows:

$$t_H = 0.693(R_A + R_B)C$$

$$t_L = 0.693(R_B)C$$

Other useful equations are:

$$\text{period} = t_H + t_L = 0.693(R_A + 2R_B)C$$

$$\text{frequency} = 1.44 / (R_A + 2R_B)C$$

$$\text{output driver duty cycle} = t_L / (t_H + t_L) = R_B / (R_A + 2R_B)$$

$$\text{output waveform duty cycle} = t_H / (t_H + t_L) = 1 - R_B / (R_A + 2R_B)$$

$$\text{low to high ratio} = t_L / t_H = R_B / (R_A + R_B)$$

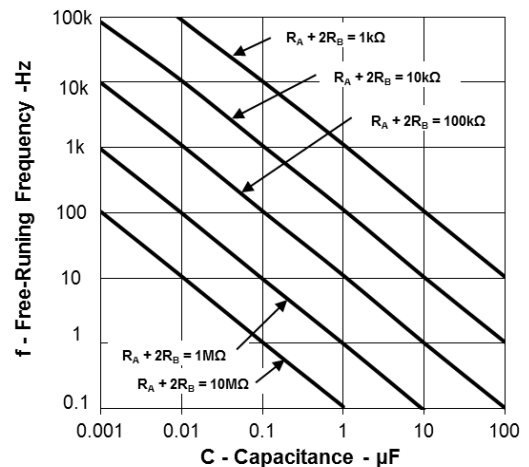

Figure 6. Free Running Frequency

Typical Applications Characteristics (Cont.)

Missing Pulse Detector

The circuit shown in Figure 7 can be used to detect a missing pulse or abnormally long spacing between consecutive pulses in a train of pulses. The timing interval of the monostable circuit is retriggered continuously by the input pulse train as long as the pulse spacing is less than the timing interval. A longer pulse spacing, missing pulse, or terminated pulse train permits the timing interval to be completed, thereby generating an output pulse as shown in Figure 8.

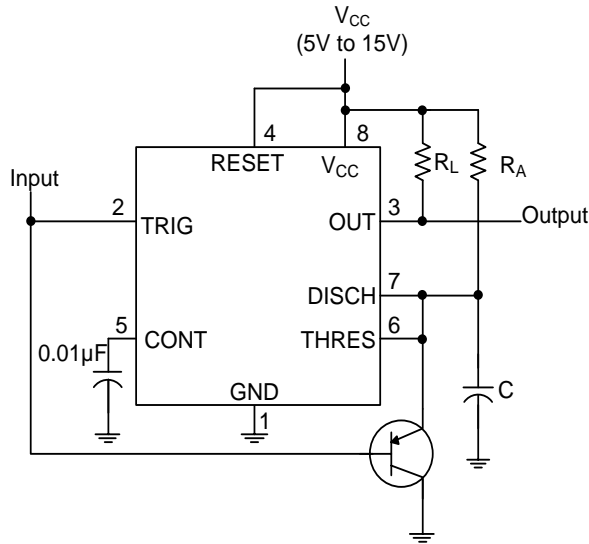

Figure 7. Circuit for Missing Pulse Dectector

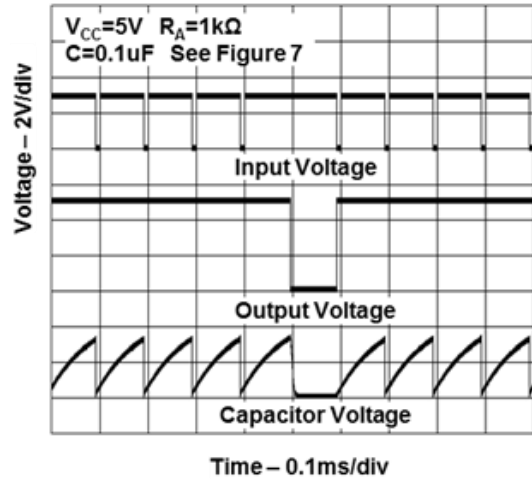

Figure 8. Timing Waveforms for Missing Pulse Dectector

Frequency Divider

By adjusting the length of the timing cycle, the basic circuit of Figure 1 can be made to operate as a frequency divider. Figure 9 shows a divide-by-three circuit that makes use of the fact that retriggering cannot occur during the timing cycle.

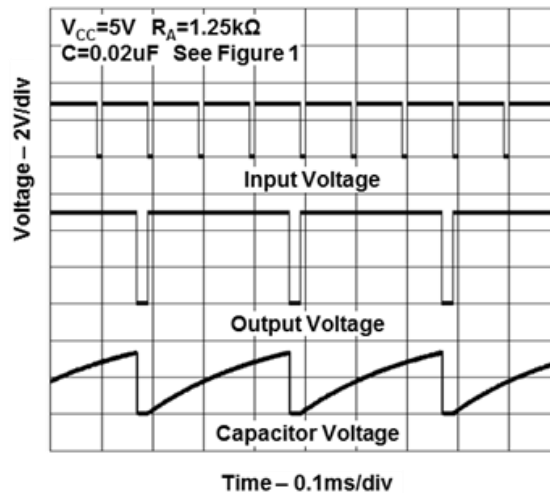
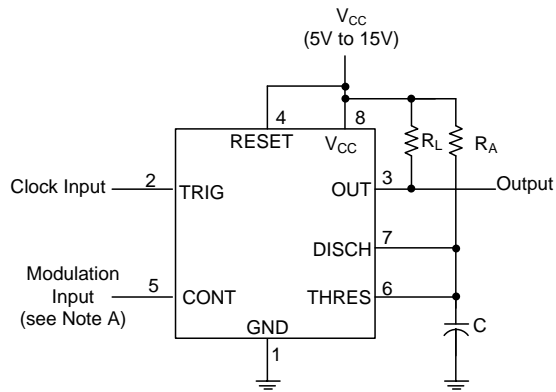

Figure 9. Divide by Three Circuit Waveforms

Typical Applications Characteristics (Cont.)

Pulse Width Modulation

The operation of the timer can be modified by modulating the internal threshold and trigger voltages, which is accomplished by applying an external voltage (or current) to CONT. Figure 10 shows a circuit for pulse-width modulation. A continuous input pulse train triggers the monostable circuit, and a control signal modulates the threshold voltage. Figure 11 shows the resulting output pulse-width modulation. While a sine-wave modulation signal is shown, any wave shape could be used.



The modulating signal can be directly or capacitively coupled to CONT. For direct coupling, the effects of modulation source voltage and impedance on the bias of the timer should be considered.

Figure 10. Circuit for Pulse Width Modulation

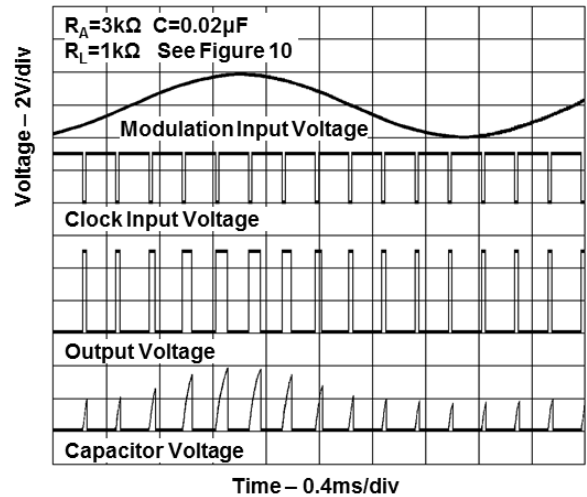
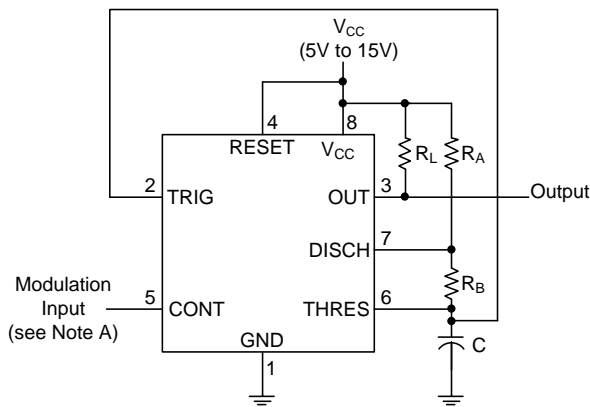

Figure 11. Pulse Width Modulation Timing Diagrams

Pulse Position Modulation

As shown in Figure 12, any of these timers can be used as a pulse-position modulator. This application modulates the threshold voltage and, thereby, the time delay, of a free-running oscillator. Figure 13 shows a triangular-wave modulation signal for such a circuit; however, any wave shape could be used.



The modulating signal can be directly or capacitively coupled to CONT. For direct coupling, the effects of modulation source voltage and impedance on the bias of the timer should be considered.

Figure 12. Circuit for Pulse Position Modulation

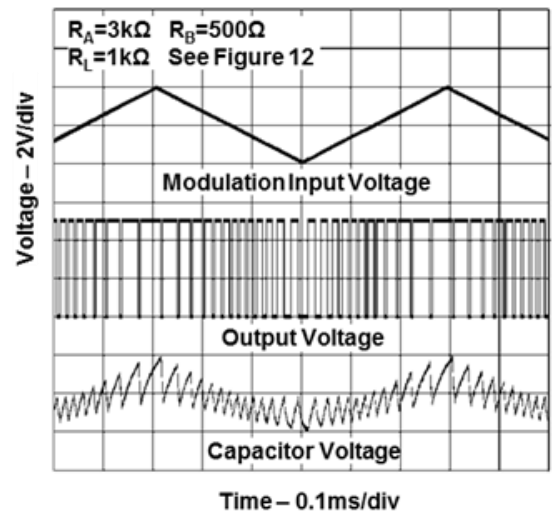
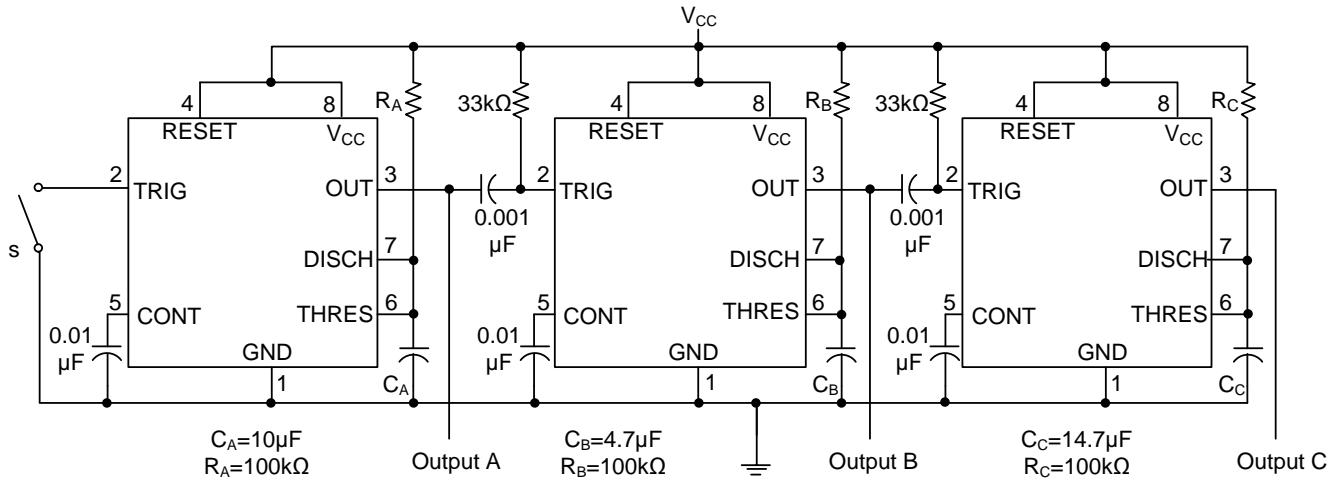

Figure 13. Pulse Position Modulation Timing Diagrams

Typical Applications Characteristics (Cont.)

Sequential Timer

Many applications, such as computers, require signals for initializing conditions during start-up. Other applications, such as test equipment, require activation of test signals in sequence. These timing circuits can be connected to provide such sequential control. The timers can be used in various combinations of astable or monostable circuit connections, with or without modulation, for extremely flexible waveform control. Figure 14 shows a sequencer circuit with possible applications in many systems, and Figure 15 shows the output waveforms.



Note A: S closes momentarily at t=0.

Figure 14. Circuit for Sequential Timer

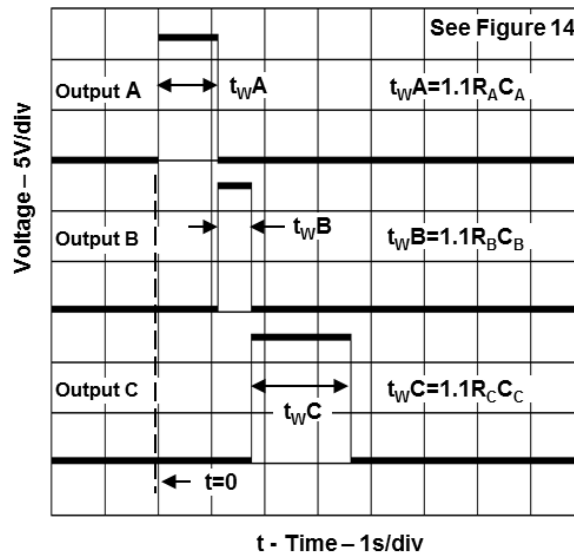
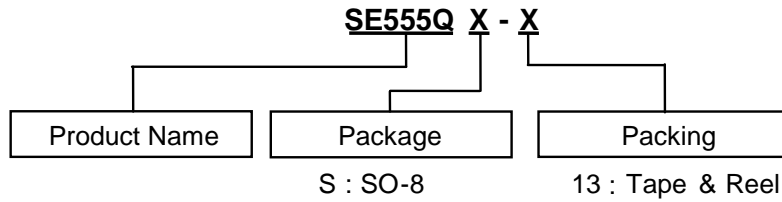

Figure 15. Sequential Timer Waveforms

Ordering Information



Part Number	Operating Temperature	Package Code	Packaging (Note 14)	13" Tape and Reel	
				Quantity	Part Number Suffix
SE555QS-13	-40 to +125°C	S	SO-8	2500/Tape & Reel	-13

Note: 14. Pad layout as shown in Diodes Incorporated's package outline PDFs, which can be found on our website at <http://www.diodes.com/package-outlines.html>.

Marking Information

SO-8

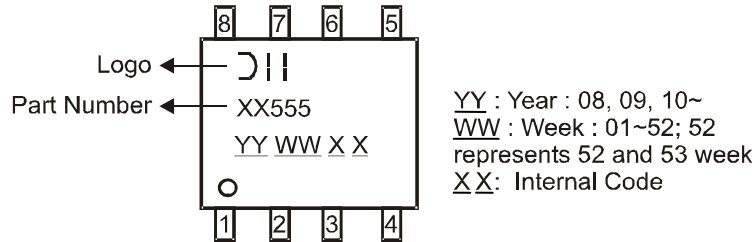

Package Outline Dimensions

Please see <http://www.diodes.com/package-outlines.html> for the latest version.

SO-8

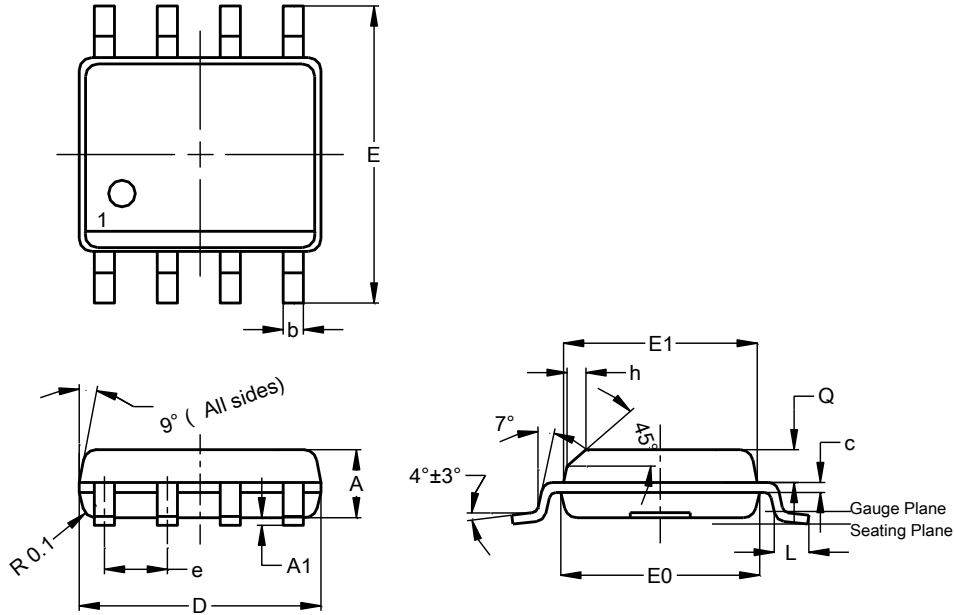

SO-8			
Dim	Min	Max	Typ
A	1.40	1.50	1.45
A1	0.10	0.20	0.15
b	0.30	0.50	0.40
c	0.15	0.25	0.20
D	4.85	4.95	4.90
E	5.90	6.10	6.00
E1	3.80	3.90	3.85
E0	3.85	3.95	3.90
e	--	--	1.27
h	--	--	0.35
L	0.62	0.82	0.72
Q	0.60	0.70	0.65
All Dimensions in mm			

Suggested Pad Layout

Please see <http://www.diodes.com/package-outlines.html> for the latest version.

SO-8

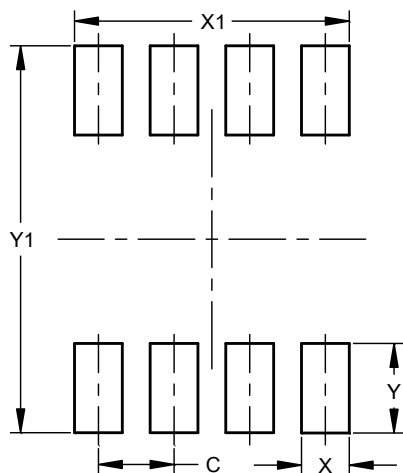

Dimensions	Value (in mm)
C	1.27
X	0.802
X1	4.612
Y	1.505
Y1	6.50

IMPORTANT NOTICE

DIODES INCORPORATED MAKES NO WARRANTY OF ANY KIND, EXPRESS OR IMPLIED, WITH REGARDS TO THIS DOCUMENT, INCLUDING, BUT NOT LIMITED TO, THE IMPLIED WARRANTIES OF MERCHANTABILITY AND FITNESS FOR A PARTICULAR PURPOSE (AND THEIR EQUIVALENTS UNDER THE LAWS OF ANY JURISDICTION).

Diodes Incorporated and its subsidiaries reserve the right to make modifications, enhancements, improvements, corrections or other changes without further notice to this document and any product described herein. Diodes Incorporated does not assume any liability arising out of the application or use of this document or any product described herein; neither does Diodes Incorporated convey any license under its patent or trademark rights, nor the rights of others. Any Customer or user of this document or products described herein in such applications shall assume all risks of such use and will agree to hold Diodes Incorporated and all the companies whose products are represented on Diodes Incorporated website, harmless against all damages.

Diodes Incorporated does not warrant or accept any liability whatsoever in respect of any products purchased through unauthorized sales channel. Should Customers purchase or use Diodes Incorporated products for any unintended or unauthorized application, Customers shall indemnify and hold Diodes Incorporated and its representatives harmless against all claims, damages, expenses, and attorney fees arising out of, directly or indirectly, any claim of personal injury or death associated with such unintended or unauthorized application.

Products described herein may be covered by one or more United States, international or foreign patents pending. Product names and markings noted herein may also be covered by one or more United States, international or foreign trademarks.

This document is written in English but may be translated into multiple languages for reference. Only the English version of this document is the final and determinative format released by Diodes Incorporated.

LIFE SUPPORT

Diodes Incorporated products are specifically not authorized for use as critical components in life support devices or systems without the express written approval of the Chief Executive Officer of Diodes Incorporated. As used herein:

A. Life support devices or systems are devices or systems which:

1. are intended to implant into the body, or
2. support or sustain life and whose failure to perform when properly used in accordance with instructions for use provided in the labeling can be reasonably expected to result in significant injury to the user.

B. A critical component is any component in a life support device or system whose failure to perform can be reasonably expected to cause the failure of the life support device or to affect its safety or effectiveness.

Customers represent that they have all necessary expertise in the safety and regulatory ramifications of their life support devices or systems, and acknowledge and agree that they are solely responsible for all legal, regulatory and safety-related requirements concerning their products and any use of Diodes Incorporated products in such safety-critical, life support devices or systems, notwithstanding any devices- or systems-related information or support that may be provided by Diodes Incorporated. Further, Customers must fully indemnify Diodes Incorporated and its representatives against any damages arising out of the use of Diodes Incorporated products in such safety-critical, life support devices or systems.

Copyright © 2017, Diodes Incorporated

www.diodes.com

Компания «Life Electronics» занимается поставками электронных компонентов импортного и отечественного производства от производителей и со складов крупных дистрибьюторов Европы, Америки и Азии.

С конца 2013 года компания активно расширяет линейку поставок компонентов по направлению коаксиальный кабель, кварцевые генераторы и конденсаторы (керамические, пленочные, электролитические), за счёт заключения дистрибьюторских договоров

Мы предлагаем:

- Конкуренеспособные цены и скидки постоянным клиентам.
- Специальные условия для постоянных клиентов.
- Подбор аналогов.
- Поставку компонентов в любых объемах, удовлетворяющих вашим потребностям.
- Приемлемые сроки поставки, возможна ускоренная поставка.
- Доставку товара в любую точку России и стран СНГ.
- Комплексную поставку.
- Работу по проектам и поставку образцов.
- Формирование склада под заказчика.
- Сертификаты соответствия на поставляемую продукцию (по желанию клиента).
- Тестирование поставляемой продукции.
- Поставку компонентов, требующих военную и космическую приемку.
- Входной контроль качества.
- Наличие сертификата ISO.

В составе нашей компании организован Конструкторский отдел, призванный помогать разработчикам, и инженерам.

Конструкторский отдел помогает осуществить:

- Регистрацию проекта у производителя компонентов.
- Техническую поддержку проекта.
- Защиту от снятия компонента с производства.
- Оценку стоимости проекта по компонентам.
- Изготовление тестовой платы монтаж и пусконаладочные работы.



Тел: +7 (812) 336 43 04 (многоканальный)

Email: org@lifeelectronics.ru