

## Main

Range of product	Zelio Logic
Product or component type	Modular smart relay

## Complementary

Local display	With
Number of control scheme lines	0...500 with FBD programming 0...240 with ladder programming
Cycle time	6...90 ms
Backup time	10 years at 77 °F (25 °C)
Clock drift	6 s/month at 77 °F (25 °C) 12 min/year at 32...131 °F (0...55 °C)
Checks	Program memory on each power up
[Us] rated supply voltage	12 V
Supply voltage limits	10.4...14.4 V
Supply current	250 mA (without extension) 400 mA (with extensions)
Power dissipation in W	3 W without extension 5 W with extensions
Reverse polarity protection	With
Discrete input number	16 conforming to EN/IEC 61131-2 type 1
Discrete input type	Resistive
Discrete input voltage	12 V DC
Discrete input current	4 mA
Counting frequency	1 kHz for discrete input
Voltage state 1 guaranteed	$\geq 7$ V for IB...IG used as discrete input circuit $\geq 5.6$ V for I1...IA and IH...IR discrete input circuit
Voltage state 0 guaranteed	$\leq 3$ V for IB...IG used as discrete input circuit $\leq 2.4$ V for I1...IA and IH...IR discrete input circuit
Current state 1 guaranteed	$\geq 2$ mA for I1...IA and IH...IR discrete input circuit $\geq 0.5$ mA for IB...IG used as discrete input circuit
Current state 0 guaranteed	$\leq 0.2$ mA for IB...IG used as discrete input circuit $\leq 0.9$ mA for I1...IA and IH...IR discrete input circuit
Input compatibility	3-wire proximity sensors PNP (discrete input)
Analogue input number	6
Analogue input type	Common mode
Analogue input range	0...10 V 0...12 V
Maximum permissible voltage	14.4 V (analogue input circuit)
Analogue input resolution	8 bits at maximum voltage
LSB value	39 mV (analogue input circuit)
Conversion time	Smart relay cycle time analogue input circuit
Conversion error	+/- 5 % at 77 °F (25 °C) for analogue input circuit +/- 6.2 % at 131 °F (55 °C) for analogue input circuit
Repeat accuracy	+/- 2 % at 131 °F (55 °C) for analogue input circuit
Operating distance	10 m between stations, with screened cable (sensor not isolated) analogue input

The information provided in this documentation contains general descriptions and/or technical characteristics of the performance of the products contained herein. This documentation is not intended as a substitute for and is not to be used for determining suitability or reliability of these products for specific user applications. It is the duty of any such user or integrator to perform the appropriate and complete risk analysis, evaluation and testing of the products with respect to the relevant specific application or use thereof. Neither Schneider Electric Industries SAS nor any of its affiliates or subsidiaries shall be responsible or liable for misuse of the information contained herein.

	circuit
Input impedance	14 kOhm (IB...IG used as analogue input circuit) 14 kOhm (IB...IG used as discrete input circuit) 2.7 kOhm (I1...IA and IH...IR discrete input circuit)
Number of outputs	10 relay output(s)
Output voltage limits	24...250 V AC (relay output) 5...30 V DC (relay output)
Contacts type and composition	NO relay output
Output thermal current	5 A for 2 outputs (relay output) 8 A for 8 outputs (relay output)
Electrical durability	500000 cycles AC-12at 230 V, 1.5 Afor relay output conforming to EN/IEC 60947-5-1 500000 cycles AC-15at 230 V, 0.9 Afor relay output conforming to EN/IEC 60947-5-1 500000 cycles DC-12at 24 V, 1.5 Afor relay output conforming to EN/IEC 60947-5-1 500000 cycles DC-13at 24 V, 0.6 Afor relay output conforming to EN/IEC 60947-5-1
Switching capacity in mA	>= 10 mAat 12 V (relay output)
Operating rate in Hz	0.1 Hz (at Ie)for relay output 10 Hz (no load)for relay output
Mechanical durability	10000000 cycles (relay output)
[Uimp] rated impulse withstand voltage	4 kV conforming to EN/IEC 60947-1 and EN/IEC 60664-1
Clock	With
Response time	10 ms (from state 0 to state 1) relay output 5 ms (from state 1 to state 0) relay output
Connections - terminals	Screw terminals, clamping capacity: 1 x 0.2...1 x 2.5 mm <sup>2</sup> AWG 25...AWG 14 semi-solid Screw terminals, clamping capacity: 1 x 0.2...1 x 2.5 mm <sup>2</sup> AWG 25...AWG 14 solid Screw terminals, clamping capacity: 1 x 0.25...1 x 2.5 mm <sup>2</sup> AWG 24...AWG 14 flexible with cable end Screw terminals, clamping capacity: 2 x 0.2...2 x 1.5 mm <sup>2</sup> AWG 24...AWG 16 solid Screw terminals, clamping capacity: 2 x 0.25...2 x 0.75 mm <sup>2</sup> AWG 24...AWG 18 flexible with cable end
Tightening torque	4.42 lbf.in (0.5 N.m)
Overvoltage category	III conforming to EN/IEC 60664-1
Product weight	0.88 lb(US) (0.4 kg)

## Environment

immunity to microbreaks	<= 1 ms repeated 20 times
product certifications	CSA C-Tick GL GOST UL
standards	EN/IEC 60068-2-27 Ea EN/IEC 60068-2-6 Fc EN/IEC 61000-4-11 EN/IEC 61000-4-12 EN/IEC 61000-4-2 level 3 EN/IEC 61000-4-3 EN/IEC 61000-4-4 level 3 EN/IEC 61000-4-5 EN/IEC 61000-4-6 level 3
IP degree of protection	IP20 (terminal block) conforming to IEC 60529 IP40 (front panel) conforming to IEC 60529
environmental characteristic	EMC directive conforming to EN/IEC 61000-6-2 EMC directive conforming to EN/IEC 61000-6-3 EMC directive conforming to EN/IEC 61000-6-4 EMC directive conforming to EN/IEC 61131-2 zone B Low voltage directive conforming to EN/IEC 61131-2
disturbance radiated/conducted	Class B conforming to EN 55022-11 group 1
pollution degree	2 conforming to EN/IEC 61131-2
ambient air temperature for operation	-4...104 °F (-20...40 °C) in non-ventilated enclosure conforming to IEC 60068-2-1 and IEC 60068-2-2 -4...131 °F (-20...55 °C) conforming to IEC 60068-2-1 and IEC 60068-2-2
ambient air temperature for storage	-40...158 °F (-40...70 °C)
operating altitude	6561.68 ft (2000 m)
altitude transport	<= 10000 ft (3048 m)

### Offer Sustainability

WARNING: This product can expose you to chemicals including:

WARNING: This product can expose you to chemicals including:

Lead and lead compounds, which is known to the State of California to cause cancer and birth defects or other reproductive harm.

Lead and lead compounds, which is known to the State of California to cause cancer and birth defects or other reproductive harm.

For more information go to [www.p65warnings.ca.gov](http://www.p65warnings.ca.gov)

For more information go to [www.p65warnings.ca.gov](http://www.p65warnings.ca.gov)

### Contractual warranty

Warranty period

18 months

## Compact and Modular Smart Relays

### Mounting on 35 mm/1.38 in. DIN Rail

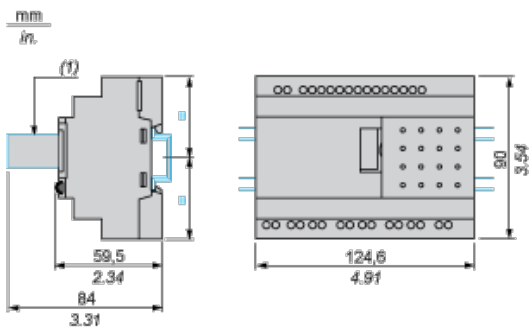

(1) With SR2USB01 or SR2BTC01

### Screw Fixing (Retractable Lugs)

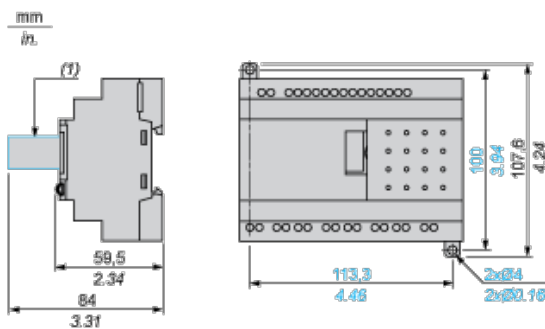

(1) With SR2USB01 or SR2BTC01

### Position of Display

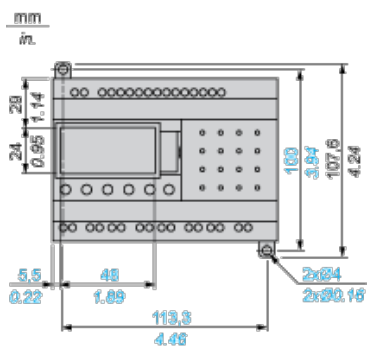

## Compact and Modular Smart Relays

### Connection of Smart Relays on DC Supply

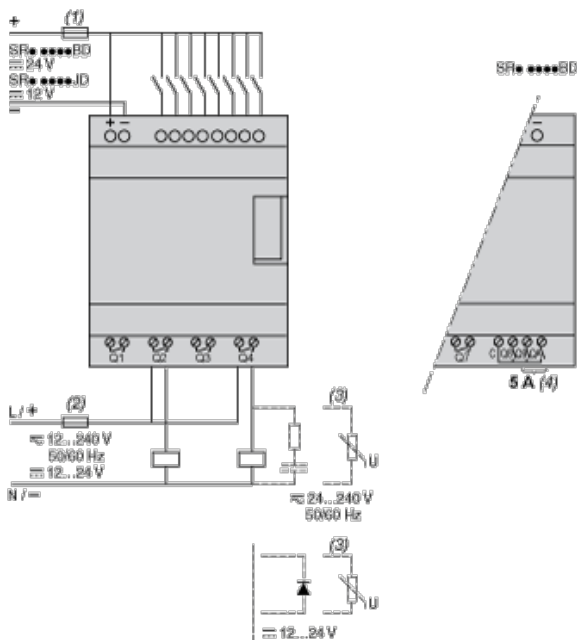

- (1) 1 A quick-blow fuse or circuit-breaker.
- (2) Fuse or circuit-breaker.
- (3) Inductive load.
- (4) Q9 and QA: 5 A (max. current in terminal C: 10 A).

### Discrete Input Used for 3-Wire Sensors

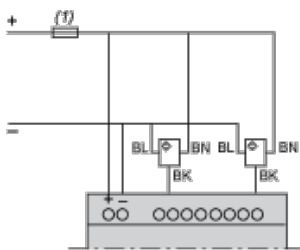

- (1) 1 A quick-blow fuse or circuit-breaker.

### Connection of Smart Relays on DC Supply, with Discrete I/O Extension Modules

#### SR3B...JD + SR3XT...JD, SR3B...BD + SR3XT...BD

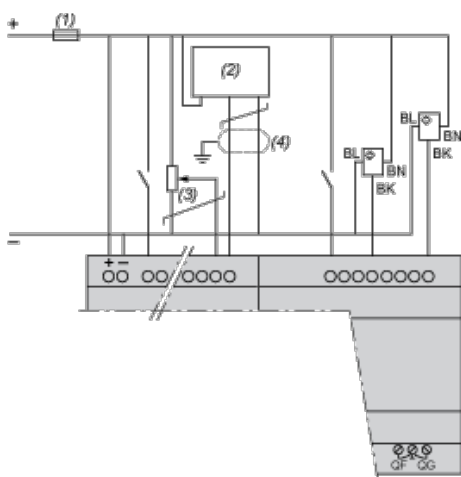

- (1) 1 A quick-blow fuse or circuit-breaker.
- (2) Ca: Analog sensor / Ta: Analog transmitter.
- (3) Recommended values: 2.2 k $\Omega$  / 0.5 W (10 k $\Omega$  max.)
- (4) Screened cables, maximum length 10 m / 32.80 feet.

**NOTE:** QF and QG : 5 A for SR3XT141••

### Compact and Modular Smart Relays

## Electrical Durability of Relay Outputs

(in millions of operating cycles, conforming to IEC/EN 60947-5-1)

DC-12 (1)

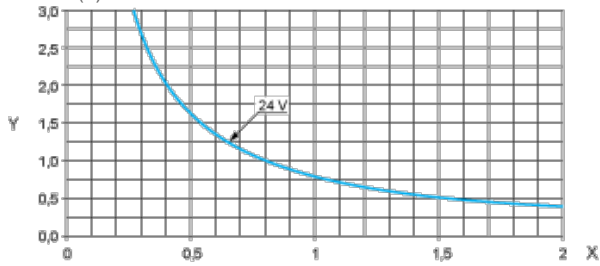

X: Current (A)

Y: Millions of operating cycles

(1) DC-12: control of resistive loads and of solid state loads isolated by opto-coupler,  $L/R \leq 1$  ms.

DC-13 (1)

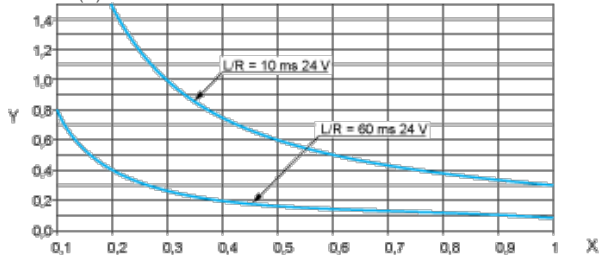

X: Current (A)

Y: Millions of operating cycles

(1) DC-13: switching electromagnets,  $L/R \leq 2 \times (U_e \times I_e)$  in ms,  $U_e$ : rated operational voltage,  $I_e$ : rated operational current (with a protection diode on the load, DC-12 curves must be used with a coefficient of 0.9 applied to the number in millions of operating cycles).

Компания «Life Electronics» занимается поставками электронных компонентов импортного и отечественного производства от производителей и со складов крупных дистрибьюторов Европы, Америки и Азии.

С конца 2013 года компания активно расширяет линейку поставок компонентов по направлению коаксиальный кабель, кварцевые генераторы и конденсаторы (керамические, пленочные, электролитические), за счёт заключения дистрибьюторских договоров

Мы предлагаем:

- Конкуренеспособные цены и скидки постоянным клиентам.
- Специальные условия для постоянных клиентов.
- Подбор аналогов.
- Поставку компонентов в любых объемах, удовлетворяющих вашим потребностям.
- Приемлемые сроки поставки, возможна ускоренная поставка.
- Доставку товара в любую точку России и стран СНГ.
- Комплексную поставку.
- Работу по проектам и поставку образцов.
- Формирование склада под заказчика.
- Сертификаты соответствия на поставляемую продукцию (по желанию клиента).
- Тестирование поставляемой продукции.
- Поставку компонентов, требующих военную и космическую приемку.
- Входной контроль качества.
- Наличие сертификата ISO.

В составе нашей компании организован Конструкторский отдел, призванный помогать разработчикам, и инженерам.

Конструкторский отдел помогает осуществить:

- Регистрацию проекта у производителя компонентов.
- Техническую поддержку проекта.
- Защиту от снятия компонента с производства.
- Оценку стоимости проекта по компонентам.
- Изготовление тестовой платы монтаж и пусконаладочные работы.



Тел: +7 (812) 336 43 04 (многоканальный)

Email: [org@lifeelectronics.ru](mailto:org@lifeelectronics.ru)