

NB2305A

3.3 V Zero Delay Clock Buffer

The NB2305A is a versatile, 3.3 V zero delay buffer designed to distribute high-speed clocks. It accepts one reference input and drives out five low-skew clocks. It is available in a 8 pin package.

The -1H version of the NB2305A operates at up to 133 MHz, and has higher drive than the -1 devices. All parts have on-chip PLL's that lock to an input clock on the REF pin. The PLL feedback is on-chip and is obtained from the CLKOUT pad.

Multiple NB2305A devices can accept the same input clock and distribute it. In this case the skew between the outputs of the two devices is guaranteed to be less than 700 ps.

All outputs have less than 200 ps of cycle-to-cycle jitter. The input and output propagation delay is guaranteed to be less than 350 ps, and the output to output skew is guaranteed to be less than 250 ps.

The NB2305A is available in two different configurations, as shown in the ordering information table. The NB2305A1 is the base part. The NB2305Ax1H* is the high drive version of the -1 and its rise and fall times are much faster than -1 part.

Features

- 15 MHz to 133 MHz Operating Range, Compatible with CPU and PCI Bus Frequencies
- Zero Input - Output Propagation Delay
- Multiple Low-Skew Outputs
- Output-Output Skew Less than 250 ps
- Device-Device Skew Less than 700 ps
- One Input Drives 5 Outputs
- Less than 200 ps Cycle-to-Cycle Jitter is Compatible with Pentium® Based Systems
- Available in 8 Pin, 150 mil SOIC Package and 8 Pin TSSOP 4.4 mm
- 3.3 V Operation, Advanced 0.35 μ CMOS Technology
- These are Pb-Free Devices



ON Semiconductor®

<http://onsemi.com>

MARKING DIAGRAMS*



SOIC-8
D SUFFIX
CASE 751

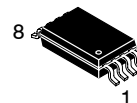
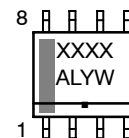

TSSOP-8
DT SUFFIX
CASE 948J



XXXX = Device Code
A = Assembly Location
L = Wafer Lot
Y = Year
W = Work Week
▪ = Pb-Free Package
(Note: Microdot may be in either location)

*For additional marking information, refer to Application Note AND8002/D.

ORDERING INFORMATION

See detailed ordering and shipping information in the package dimensions section on page 6 of this data sheet.

*x = C for Commercial; I for Industrial.

NB2305A

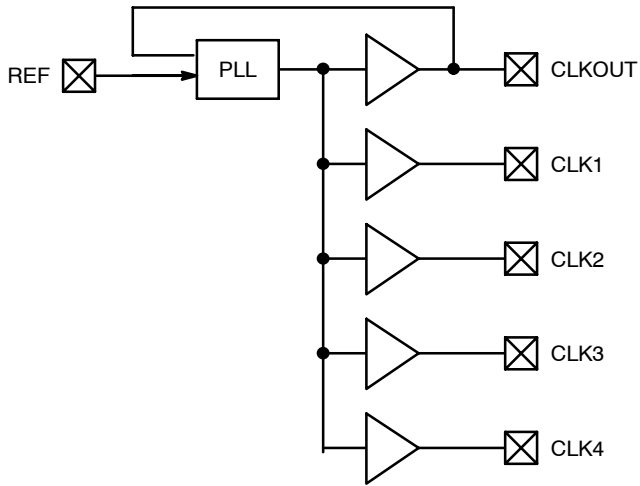

Figure 1. Block Diagram

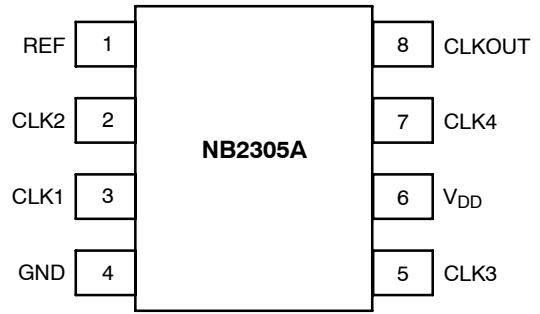

Figure 2. Pin Configuration

Table 1. PIN DESCRIPTION

Pin #	Pin Name	Description
1	REF (Note1)	Input reference frequency, 5 V tolerant input.
2	CLK2 (Note 2)	Buffered clock output.
3	CLK1 (Note 2)	Buffered clock output.
4	GND	Ground.
5	CLK3 (Note 2)	Buffered clock output.
6	V _{DD}	3.3 V supply.
7	CLK4 (Note 2)	Buffered clock output.
8	CLKOUT (Note 2)	Buffered clock output, internal feedback on this pin.

1. Weak pulldown.
2. Weak pulldown on all outputs.

NB2305A

Table 2. MAXIMUM RATINGS

Parameter	Min	Max	Unit
Supply Voltage to Ground Potential	-0.5	+7.0	V
DC Input Voltage (Except REF)	-0.5	$V_{DD} + 0.5$	V
DC Input Voltage (REF)	-0.5	7	V
Storage Temperature	-65	+150	°C
Maximum Soldering Temperature (10 sec)		260	°C
Junction Temperature		150	°C
Static Discharge Voltage (per MIL-STD-883, Method 3015)		>2000	V

Maximum ratings are those values beyond which device damage can occur. Maximum ratings applied to the device are individual stress limit values (not normal operating conditions) and are not valid simultaneously. If these limits are exceeded, device functional operation is not implied, damage may occur and reliability may be affected.

Table 3. OPERATING CONDITIONS FOR COMMERCIAL AND INDUSTRIAL TEMPERATURE DEVICES

Parameter	Description	Min	Max	Unit
V_{DD}	Supply Voltage	3.0	3.6	V
T_A	Operating Temperature (Ambient Temperature)	Commercial Industrial	0 70 85	°C
C_L	Load Capacitance, below 100 MHz		30	pF
C_L	Load Capacitance, from 100 MHz to 133 MHz		10	pF
C_{IN}	Input Capacitance		7	pF

Table 4. ELECTRICAL CHARACTERISTICS FOR COMMERCIAL AND INDUSTRIAL TEMPERATURE DEVICES

Parameter	Description	Test Conditions	Min	Max	Unit
V_{IL}	Input LOW Voltage (Note 3)			0.8	V
V_{IH}	Input HIGH Voltage (Note 3)		2.0		V
I_{IL}	Input LOW Current	$V_{IN} = 0\text{ V}$		50	μA
I_{IH}	Input HIGH Current	$V_{IN} = V_{DD}$		100	μA
V_{OL}	Output LOW Voltage	$I_{OL} = 8\text{ mA} (-1)$ $I_{OL} = 12\text{ mA} (-1H)$		0.4	V
V_{OH}	Output HIGH Voltage	$I_{OH} = -8\text{ mA} (-1)$ $I_{OH} = -12\text{ mA} (-1H)$	2.4		V
I_{DD}	Supply Current (Commercial Temp)	Unloaded outputs at 66.67 MHz, Select inputs at V_{DD}		34	mA
I_{DD}	Supply Current (Industrial Temp)	Unloaded outputs at 100 MHz 66.67 MHz 33 MHz Select inputs at V_{DD} or GND, at Room Temp		50 34 19	mA

3. REF input has a threshold voltage of $V_{DD}/2$.

NB2305A

Table 5. SWITCHING CHARACTERISTICS (Commercial and Industrial) (Note 4)

Parameter	Description	Test Conditions	Min	Typ	Max	Unit
1/t ₁	Output Frequency	30 pF load 10 pF load	15 15		100 133.33	MHz
1/t ₁	Duty Cycle = (t ₂ / t ₁) * 100 (-1, -1H) (-1H)	Measured at 1.4 V, F _{OUT} = 66.67 MHz < 50 MHz	40 45	50 50	60 55	%
t ₃	Output Rise Time (-1) (-1H)	Measured between 0.8 V and 2.0 V			2.5 1.5	ns
t ₄	Output Fall Time (-1) (-1H)	Measured between 2.0 V and 0.8 V			2.5 1.5	ns
t ₅	Output-to-Output Skew	All outputs equally loaded			250	ps
t ₆	Delay, REF Rising Edge to CLKOUT Rising Edge	Measured at V _{DD} /2		0	±350	ps
t ₇	Device-to-Device Skew	Measured at V _{DD} /2 on the CLKOUT pins of the device		0	700	ps
t _J	Cycle-to-Cycle Jitter	Measured at 66.67 MHz, loaded outputs			200	ps
t _{LOCK}	PLL Lock Time	Stable power supply, valid clock presented on REF pin			1.0	ms
t _{r_in}	REF Input Rise Time	Measured between 0.8 V to 2.0 V			1.0	ns
t _{f_in}	REF Input Rise Fall Time	Measured between 2.0 V to 0.8 V			1.0	ns

4. All parameters specified with loaded outputs.

Zero Delay and Skew Control

All outputs should be uniformly loaded to achieve Zero Delay between input and output. Since the CLKOUT pin is the internal feedback to the PLL, its relative loading can adjust the input-output delay.

For applications requiring zero input-output delay, all outputs, including CLKOUT, must be equally loaded. Even if CLKOUT is not used, it must have a capacitive load equal to that on other outputs, for obtaining zero-input-output delay.

SWITCHING WAVEFORMS

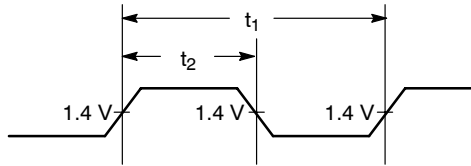

Figure 3. Duty Cycle Timing

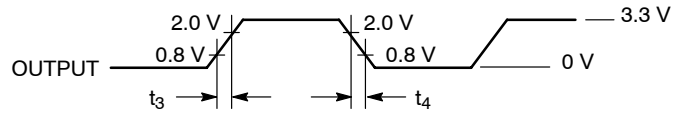

Figure 4. All Outputs Rise/Fall Time

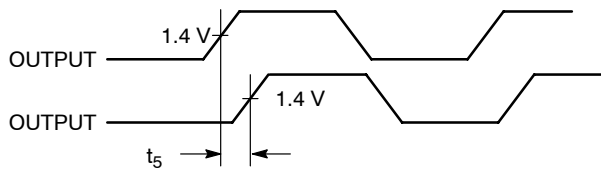

Figure 5. Output - Output Skew

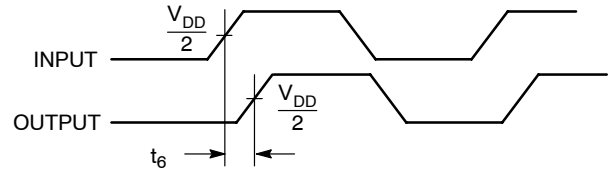

Figure 6. Input - Output Propagation Delay

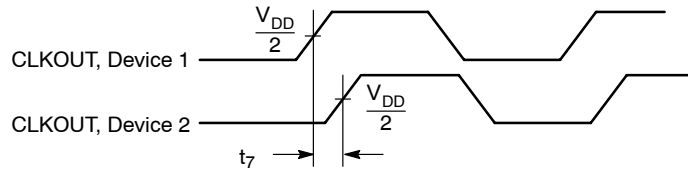

Figure 7. Device - Device Skew

NB2305A

TEST CIRCUITS

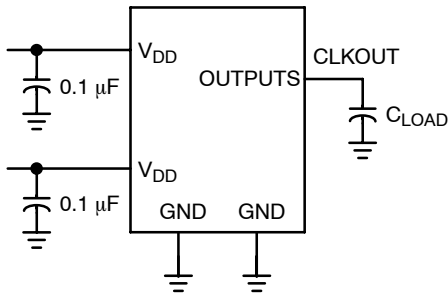

Figure 8. Test Circuit #1

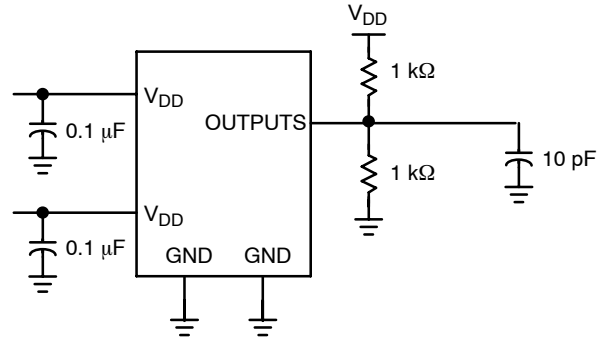

Figure 9. Test Circuit #2
For parameter t_b (output slew rate) on -1H devices

ORDERING INFORMATION

Device	Marking	Operating Range	Package	Shipping [†]	Availability
NB2305AC1DG	5C1	Commercial	SOIC-8 (Pb-Free)	98 Units / Rail	Now
NB2305AC1DR2G	5C1	Commercial	SOIC-8 (Pb-Free)	2500 Tape & Reel	Now
NB2305AI1DG	5I1	Industrial	SOIC-8 (Pb-Free)	98 Units / Rail	Now
NB2305AI1DR2G	5I1	Industrial	SOIC-8 (Pb-Free)	2500 Tape & Reel	Now
NB2305AC1HDG	5C1H	Commercial	SOIC-8 (Pb-Free)	98 Units / Rail	Now
NB2305AC1HDR2G	5C1H	Commercial	SOIC-8 (Pb-Free)	2500 Tape & Reel	Now
NB2305AI1HDG	5I1H	Industrial	SOIC-8 (Pb-Free)	98 Units / Rail	Now
NB2305AI1HDR2G	5I1H	Industrial	SOIC-8 (Pb-Free)	2500 Tape & Reel	Now
NB2305AC1DTG	5C1	Commercial	TSSOP-8 (Pb-Free)	100 Units / Rail	Now
NB2305AC1DTR2G	5C1	Commercial	TSSOP-8 (Pb-Free)	2500 Tape & Reel	Now
NB2305AI1DTG	5I1	Industrial	TSSOP-8 (Pb-Free)	100 Units / Rail	Now
NB2305AI1DTR2G	5I1	Industrial	TSSOP-8 (Pb-Free)	2500 Tape & Reel	Now
NB2305AC1HDTG	5C1H	Commercial	TSSOP-8 (Pb-Free)	100 Units / Rail	Now
NB2305AC1HDTR2G	5C1H	Commercial	TSSOP-8 (Pb-Free)	2500 Tape & Reel	Now
NB2305AI1HDTG	5I1H	Industrial	TSSOP-8 (Pb-Free)	100 Units / Rail	Now
NB2305AI1HDTR2G	5I1H	Industrial	TSSOP-8 (Pb-Free)	2500 Tape & Reel	Now

[†]For information on tape and reel specifications, including part orientation and tape sizes, please refer to our Tape and Reel Packaging Specifications Brochure, BRD8011/D.

NB2305A

PACKAGE DIMENSIONS

SOIC-8 NB
CASE 751-07
ISSUE AG

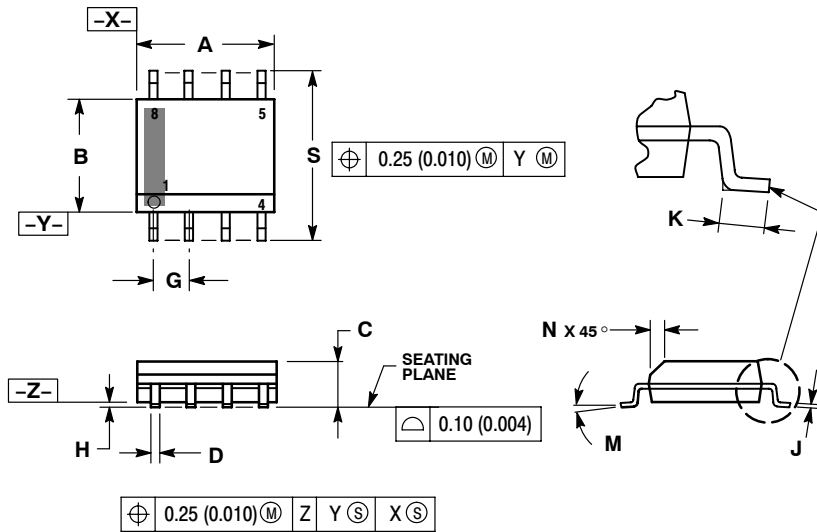

NOTES:

1. DIMENSIONING AND TOLERANCING PER ANSI Y14.5M, 1982.
2. CONTROLLING DIMENSION: MILLIMETER.
3. DIMENSION A AND B DO NOT INCLUDE MOLD PROTRUSION.
4. MAXIMUM MOLD PROTRUSION 0.15 (0.006) PER SIDE.
5. DIMENSION D DOES NOT INCLUDE DAMBAR PROTRUSION. ALLOWABLE DAMBAR PROTRUSION SHALL BE 0.127 (0.005) TOTAL IN EXCESS OF THE D DIMENSION AT MAXIMUM MATERIAL CONDITION.
6. 751-01 THRU 751-06 ARE OBSOLETE. NEW STANDARD IS 751-07.

DIM	MILLIMETERS		INCHES	
	MIN	MAX	MIN	MAX
A	4.80	5.00	0.189	0.197
B	3.80	4.00	0.150	0.157
C	1.35	1.75	0.053	0.069
D	0.33	0.51	0.013	0.020
G	1.27 BSC		0.050 BSC	
H	0.10	0.25	0.004	0.010
J	0.19	0.25	0.007	0.010
K	0.40	1.27	0.016	0.050
M	0° 8°		0° 8°	
N	0.25	0.50	0.010	0.020
S	5.80	6.20	0.228	0.244

SOLDERING FOOTPRINT*

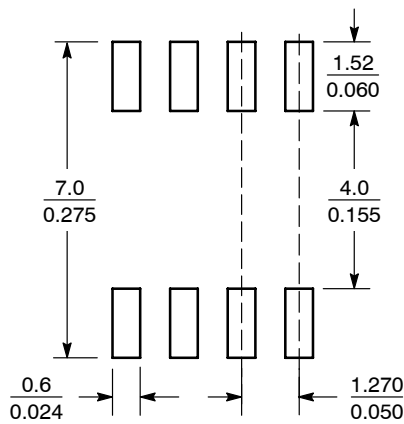

SCALE 6:1 $\left(\frac{\text{mm}}{\text{inches}} \right)$

*For additional information on our Pb-Free strategy and soldering details, please download the ON Semiconductor Soldering and Mounting Techniques Reference Manual, SOLDERRM/D.

NB2305A

PACKAGE DIMENSIONS

TSSOP-8
CASE 948J-01
ISSUE A

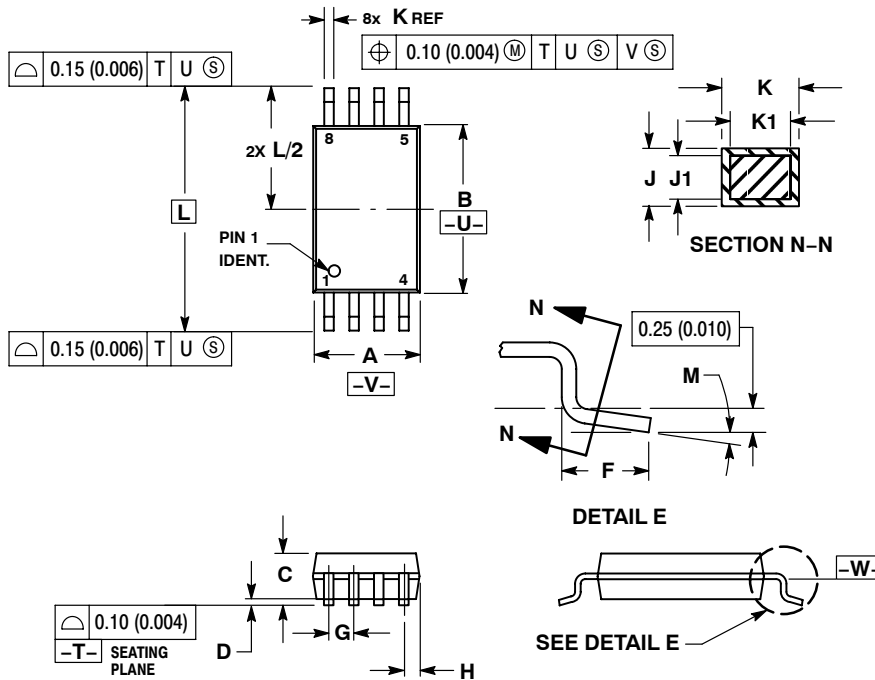

NOTES:

- DIMENSIONING AND TOLERANCING PER ANSI Y14.5M, 1982.
- CONTROLLING DIMENSION: MILLIMETER.
- DIMENSION A DOES NOT INCLUDE MOLD FLASH. PROTRUSIONS OR GATE BURRS. MOLD FLASH OR GATE BURRS SHALL NOT EXCEED 0.15 (0.006) PER SIDE.
- DIMENSION B DOES NOT INCLUDE INTERLEAD FLASH OR PROTRUSION. INTERLEAD FLASH OR PROTRUSION SHALL NOT EXCEED 0.25 (0.010) PER SIDE.
- DIMENSION K DOES NOT INCLUDE DAMBAR PROTRUSION. ALLOWABLE DAMBAR PROTRUSION SHALL BE 0.08 (0.003) TOTAL IN EXCESS OF THE K DIMENSION AT MAXIMUM MATERIAL CONDITION.
- TERMINAL NUMBERS ARE SHOWN FOR REFERENCE ONLY.
- DIMENSION A AND B ARE TO BE DETERMINED AT DATUM PLANE -W-.

DIM	MILLIMETERS		INCHES	
	MIN	MAX	MIN	MAX
A	2.90	3.10	0.114	0.122
B	4.30	4.50	0.169	0.177
C	---	1.20	---	0.047
D	0.05	0.15	0.002	0.006
F	0.50	0.75	0.020	0.030
G	0.65 BSC		0.026 BSC	
H	0.50	0.60	0.020	0.024
J	0.09	0.20	0.004	0.008
J1	0.09	0.16	0.004	0.006
K	0.19	0.30	0.007	0.012
K1	0.19	0.25	0.007	0.010
L	6.40 BSC		0.252 BSC	
M	0°	8°	0°	8°

Pentium is a registered trademark of Intel Corporation.
Licensed under US patent Nos 5,488,627, 6,646,463 and 5,631,920.

ON Semiconductor and are registered trademarks of Semiconductor Components Industries, LLC (SCILLC). SCILLC reserves the right to make changes without further notice to any products herein. SCILLC makes no warranty, representation or guarantee regarding the suitability of its products for any particular purpose, nor does SCILLC assume any liability arising out of the application or use of any product or circuit, and specifically disclaims any and all liability, including without limitation special, consequential or incidental damages. "Typical" parameters which may be provided in SCILLC data sheets and/or specifications can and do vary in different applications and actual performance may vary over time. All operating parameters, including "Typicals" must be validated for each customer application by customer's technical experts. SCILLC does not convey any license under its patent rights nor the rights of others. SCILLC products are not designed, intended, or authorized for use as components in systems intended for surgical implant into the body, or other applications intended to support or sustain life, or for any other application in which the failure of the SCILLC product could create a situation where personal injury or death may occur. Should Buyer purchase or use SCILLC products for any such unintended or unauthorized application, Buyer shall indemnify and hold SCILLC and its officers, employees, subsidiaries, affiliates, and distributors harmless against all claims, costs, damages, and expenses, and reasonable attorney fees arising out of, directly or indirectly, any claim of personal injury or death associated with such unintended or unauthorized use, even if such claim alleges that SCILLC was negligent regarding the design or manufacture of the part. SCILLC is an Equal Opportunity/Affirmative Action Employer. This literature is subject to all applicable copyright laws and is not for resale in any manner.

PUBLICATION ORDERING INFORMATION

LITERATURE FULFILLMENT:
Literature Distribution Center for ON Semiconductor
P.O. Box 5163, Denver, Colorado 80217 USA
Phone: 303-675-2175 or 800-344-3860 Toll Free USA/Canada
Fax: 303-675-2176 or 800-344-3867 Toll Free USA/Canada
Email: orderlit@onsemi.com

N. American Technical Support: 800-282-9855 Toll Free
USA/Canada
Europe, Middle East and Africa Technical Support:
Phone: 421 33 790 2910
Japan Customer Focus Center
Phone: 81-3-5773-3850

ON Semiconductor Website: www.onsemi.com
Order Literature: <http://www.onsemi.com/orderlit>
For additional information, please contact your local Sales Representative

Компания «Life Electronics» занимается поставками электронных компонентов импортного и отечественного производства от производителей и со складов крупных дистрибьюторов Европы, Америки и Азии.

С конца 2013 года компания активно расширяет линейку поставок компонентов по направлению коаксиальный кабель, кварцевые генераторы и конденсаторы (керамические, пленочные, электролитические), за счёт заключения дистрибьюторских договоров

Мы предлагаем:

- Конкурентоспособные цены и скидки постоянным клиентам.
- Специальные условия для постоянных клиентов.
- Подбор аналогов.
- Поставку компонентов в любых объемах, удовлетворяющих вашим потребностям.
- Приемлемые сроки поставки, возможна ускоренная поставка.
- Доставку товара в любую точку России и стран СНГ.
- Комплексную поставку.
- Работу по проектам и поставку образцов.
- Формирование склада под заказчика.
- Сертификаты соответствия на поставляемую продукцию (по желанию клиента).
- Тестирование поставляемой продукции.
- Поставку компонентов, требующих военную и космическую приемку.
- Входной контроль качества.
- Наличие сертификата ISO.

В составе нашей компании организован Конструкторский отдел, призванный помогать разработчикам, и инженерам.

Конструкторский отдел помогает осуществить:

- Регистрацию проекта у производителя компонентов.
- Техническую поддержку проекта.
- Защиту от снятия компонента с производства.
- Оценку стоимости проекта по компонентам.
- Изготовление тестовой платы монтаж и пусконаладочные работы.



Тел: +7 (812) 336 43 04 (многоканальный)

Email: org@lifeelectronics.ru