

VSC7426

24-Port Layer-2 Gigabit Ethernet Switch with 12 Fully Integrated Copper PHYs and Embedded 416 MHz CPU

Microsemi's next-generation switch delivers the industry's lowest power GbE switching solution.

The VSC7426 is the industry's first fully integrated 24-port Gigabit Ethernet switch with 12 copper PHYs in a single package. In conjunction with Microsemi's 12-port PHY VSC8512 or VSC8522, a 24-port switch can be designed using only two ICs.

The VSC7426 leverages Microsemi's new 65 nm SimpliPHY™ technology, resulting in the one of the most cost-effective and lowest power consumption devices in the industry. The dual chip solution combines the most advanced Ethernet energy efficiency features for bringing green technology solutions to market.

The VSC7426 provides a rich set of Small Medium Enterprise (SME) Ethernet switching features such as Layer-2 forwarding with advanced TCAM-based VLAN and QoS processing, enabling the delivery of differentiated services. Security is ensured through frame processing using a TCAM-based Versatile Content Aware Processor (VCAP-II). The VSC7426 contains a powerful 416 MHz CPU, enabling full management of the switch.

A comprehensive application programming interface (API) and software development package is available for Layer-2 Managed Ethernet applications for faster time-to-market. The software API package integrates easily with third-party software, preserving existing software investments.

Highlights

- Supports IEEE 802.3az and green energy efficiency modes with ActiPHY™ and PerfectReach™
- Lowest BOM solution requires only two ICs
- Three QSGMII MAC interfaces

Applications

- Ethernet switches
- Edge and Access platforms
- Customer-premises equipment (CPE) and network termination equipment (NTE)

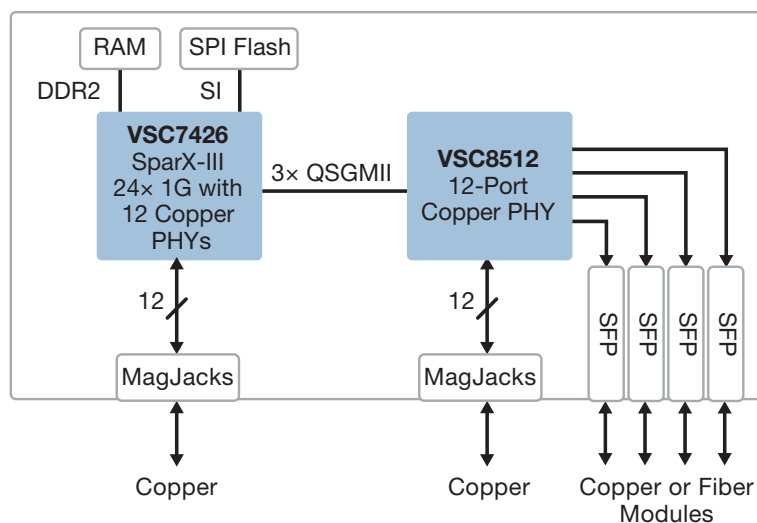

VSC7426

24-Port Layer-2 Gigabit Ethernet Switch with 12 Fully Integrated Copper PHYs and Embedded 416 MHz CPU

Best-In-Class Power Consumption

- Lowest power 24-port Gigabit Ethernet switch available in the market
- Green energy efficiency modes including ActiPHY™, Perfect-Reach™, and Draft IEEE 802.3az
- Two ICs reduce overall power requirements
- Optimal power consumption for all link speeds

Features

- Twelve integrated IEEE 802.3ab-compliant 10/100/1000BASE-T Ethernet copper transceivers with VeriPHY™ cable diagnostics
- Three QSGMII MAC interfaces
- Integrated 416 MHz MIPS CPU with DDR2 and serial Flash interface
- Advanced Access and QoS Control Lists (ACL and QCL) support through TCAM-based match patterns
- Integrated temperature monitoring circuit
- Integrated fan controller
- 8 K MAC addresses and 4 K VLAN support
- Supports IEEE 1149.1 JTAG boundary scan, IEEE 1149.6 AC-JTAG, QSGMII v1.2, and 100BASE-FX and 1000BASE-X

Layer 2 Switching

- 24-port Gigabit Ethernet switch with nonblocking wire-speed performance
- Link aggregation (IEEE 802.3ad) with programmable traffic distribution based on Layer 2 through Layer 4 information
- Wire-speed hardware-based learning and CPU-based learning configurable per port

- Independent and shared VLAN learning
- Jumbo frame support up to 12.2 kilobytes with per-port programmable MTU
- Q-in-Q tagging support
- 4 megabits of integrated shared packet memory
- Audio and video bridging (AVB)

QoS

- Eight QoS queues per port with strict or deficit-weighted round robin scheduling
- QoS classification based on IEEE 802.1p, EtherType, VID, MAC/IP addresses, IPv4/IPv6 DSCP, and UDP/TCP ports and ranges
- Data rate shaper and policer per-queue, per-port for both ingress and egress directions
- Full-duplex flow control (IEEE 802.3x) and half-duplex back-pressure, symmetric and asymmetric
- Multicast and broadcast storm control with flooding control

Key Specifications

- 1 V core power supply
- 1.8 V and 2.5 V I/O power supplies
- 27 mm × 27 mm thermally enhanced plastic BGA package

Related Products

Visit www.microsemi.com for information about these related products:

- Ethernet switches
- 1G copper PHYs

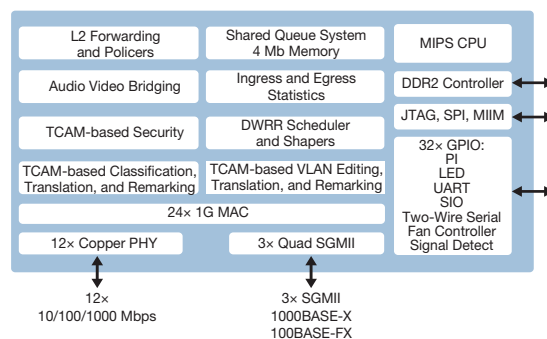

Microsemi Corporate Headquarters
 One Enterprise, Aliso Viejo, CA 92656 USA
 Within the USA: +1 (800) 713-4113
 Outside the USA: +1 (949) 380-6100
 Sales: +1 (949) 380-6136
 Fax: +1 (949) 215-4996
 email: sales.support@microsemi.com
www.microsemi.com

Microsemi Corporation (Nasdaq: MSCC) offers a comprehensive portfolio of semiconductor and system solutions for communications, defense and security, aerospace, and industrial markets. Products include high-performance and radiation-hardened analog mixed-signal integrated circuits, FPGAs, SoCs, and ASICs; power management products; timing and synchronization devices and precise time solutions; voice processing devices; RF solutions; discrete components; enterprise storage and communications solutions, security technologies, and scalable anti-tamper products; Ethernet solutions; Power-over-Ethernet ICs and midspans; custom design capabilities and services. Microsemi is headquartered in Aliso Viejo, California, and has approximately 4,800 employees worldwide. Learn more at www.microsemi.com.

Компания «Life Electronics» занимается поставками электронных компонентов импортного и отечественного производства от производителей и со складов крупных дистрибьюторов Европы, Америки и Азии.

С конца 2013 года компания активно расширяет линейку поставок компонентов по направлению коаксиальный кабель, кварцевые генераторы и конденсаторы (керамические, пленочные, электролитические), за счёт заключения дистрибьюторских договоров

Мы предлагаем:

- Конкурентоспособные цены и скидки постоянным клиентам.
- Специальные условия для постоянных клиентов.
- Подбор аналогов.
- Поставку компонентов в любых объемах, удовлетворяющих вашим потребностям.
- Приемлемые сроки поставки, возможна ускоренная поставка.
- Доставку товара в любую точку России и стран СНГ.
- Комплексную поставку.
- Работу по проектам и поставку образцов.
- Формирование склада под заказчика.
- Сертификаты соответствия на поставляемую продукцию (по желанию клиента).
- Тестирование поставляемой продукции.
- Поставку компонентов, требующих военную и космическую приемку.
- Входной контроль качества.
- Наличие сертификата ISO.

В составе нашей компании организован Конструкторский отдел, призванный помогать разработчикам, и инженерам.

Конструкторский отдел помогает осуществить:

- Регистрацию проекта у производителя компонентов.
- Техническую поддержку проекта.
- Защиту от снятия компонента с производства.
- Оценку стоимости проекта по компонентам.
- Изготовление тестовой платы монтаж и пусконаладочные работы.



Тел: +7 (812) 336 43 04 (многоканальный)

Email: org@lifeelectronics.ru