

Micropower quad CMOS voltage comparator

Datasheet - production data

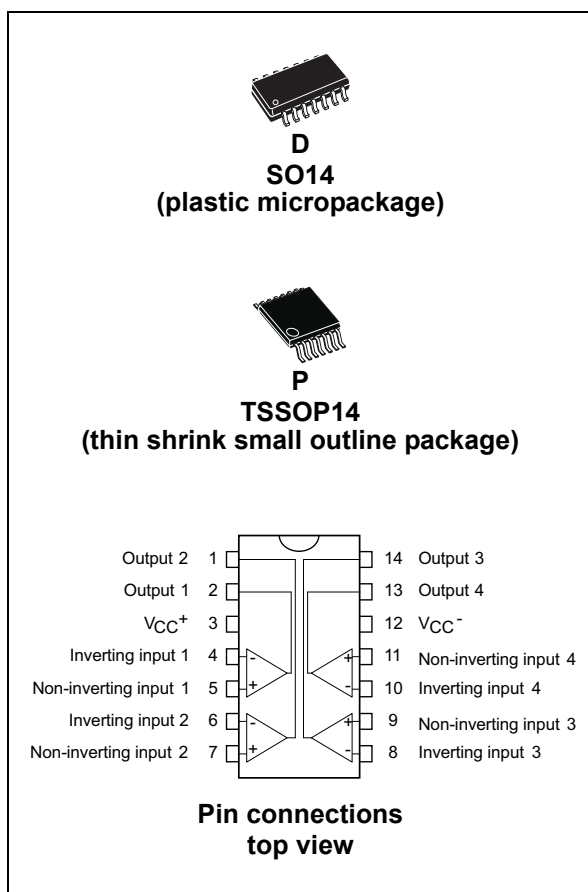

Features

- Extremely low supply current: 9 μ A typ./comparator
- Wide single supply range 2.7 V to 16 V or dual supplies (± 1.35 V to ± 8 V)
- Extremely low input bias current: 1 pA typ.
- Extremely low input offset current: 1 pA typ.
- Input common-mode voltage range includes GND
- High input impedance: 10^{12} Ω typ.
- Fast response time: 1.5 μ s typ. for 5 mV overdrive
- Pin-to-pin and functionally compatible with bipolar LM339 device

Description

The TS339 device is a micro-power, CMOS, quad voltage comparator with extremely low consumption of 9 μ A typ./comparator (20 times less than the bipolar LM339). Similar performances are offered by the quad micro-power comparator TS3704 with a push-pull CMOS output. Thus response times remain similar to the LM339 device.

Table 1. Device summary

Order code	Temperature range	Package	Packaging	Marking
TS339CD/CDT	0 °C, 70 °C	SO14	Tube or tape and reel	S339C
TS339IDT	-40 °C, 125 °C			S339I
TS339IPT			TSSOP14	Tape and reel

Contents

1	Absolute maximum ratings	3
2	Typical application schematics	4
3	Electrical characteristics	5
4	Package information	7
	4.1 SO14 package	8
	4.2 TSSOP14 package	9
5	Revision history	10

1 Absolute maximum ratings

Table 2. Key parameters and their absolute maximum ratings

Symbol	Parameter	Value	Unit
V_{CC}^+	Supply voltage ⁽¹⁾	18	V
V_{id}	Differential input voltage ⁽²⁾	±18	
V_i	Input voltage ⁽³⁾	18	
V_o	Output voltage	18	
I_o	Output current	20	mA
I_F	Forward current in ESD protection diodes on inputs ⁽⁴⁾	50	
P_d	Power dissipation ⁽⁵⁾		mW
	SO14 TSSOP14	830 710	
T_{stg}	Storage temperature range	-65 to +150	°C
ESD	HBM: human body model ⁽⁶⁾	50	V
	MM: machine model ⁽⁷⁾	40	
	CDM: charged device model	800	

- All voltage values, except the differential voltage, are with respect to network ground terminal.
- Differential voltages are the non-inverting input terminal with respect to the inverting input terminal.
- Excursions of input voltages may exceed the power supply level. As long as the common mode voltage [$V_{icm}=(V_{in}^+ + V_{in}^-)/2$] remains within the specified range, the comparator will provide a stable output state. However, the maximum current through the ESD diodes (I_F) of the input stage must strictly be observed.
- Guaranteed by design.
- P_d is calculated with $T_{amb} = +25\text{ °C}$, $T_j = +150\text{ °C}$ and
 $R_{thja} = 150\text{ °C/W}$ for SO14 package
 $R_{thja} = 175\text{ °C/W}$ for TSSOP14 package.
- Human body model, 100pF discharged through a 1.5 kΩ resistor into pin of device.
- Machine model ESD, a 200 pF cap is charged to the specified voltage, then discharged directly into the IC with no external series resistor (internal resistor < 5 Ω), into pin to pin of device.

2 Typical application schematics

Figure 1. Schematic diagram (for 1/4 TS339)

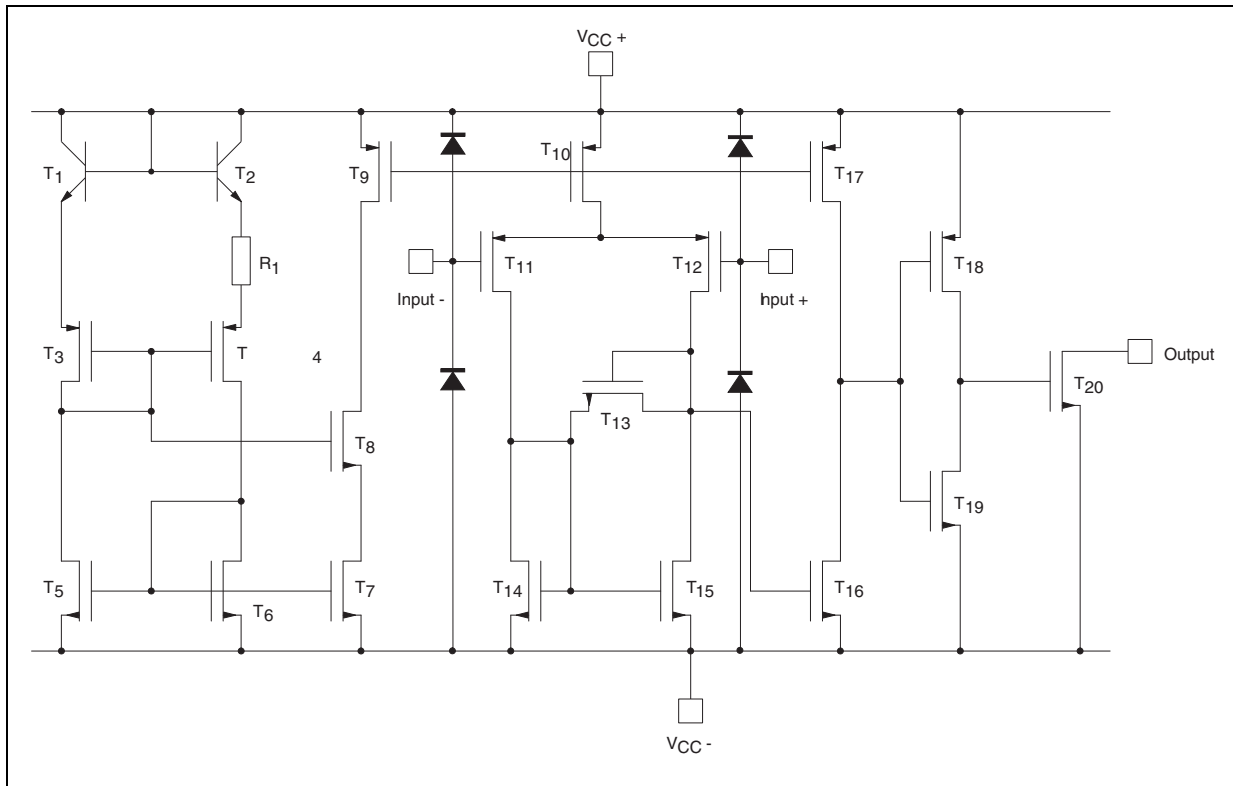

3 Electrical characteristics

Table 3. $V_{CC}^+ = 3\text{ V}$, $V_{CC}^- = 0\text{ V}$, $T_{amb} = 25\text{ °C}$ (unless otherwise specified)

Symbol	Parameter	Min.	Typ.	Max.	Unit
V_{io}	Input offset voltage ⁽¹⁾ $V_{ic} = 1.5\text{ V}$ $T_{min.} \leq T_{amb} \leq T_{max.}$			5 6.5	mV
I_{io}	Input offset current ⁽²⁾ $V_{ic} = 1.5\text{ V}$ $T_{min.} \leq T_{amb} \leq T_{max.}$		1	300	pA
I_{ib}	Input bias current ⁽²⁾ $V_{ic} = 1.5\text{ V}$ $T_{min.} \leq T_{amb} \leq T_{max.}$		1	600	
V_{icm}	Input common mode voltage range $T_{min.} \leq T_{amb} \leq T_{max.}$	0 0		$V_{CC}^+ - 1.2$ $V_{CC}^+ - 1.5$	V
CMR	Common-mode rejection ratio $V_{ic} = V_{icm\ min.}$		70		dB
SVR	Supply voltage rejection ratio $V_{CC}^+ = 3\text{ V to }5\text{ V}$		70		
I_{OH}	High level output current $V_{id} = +1\text{ V}$, $V_{OH} = 3\text{ V}$ $T_{min.} \leq T_{amb} \leq T_{max.}$		2	40 1000	nA
V_{OL}	Low level output voltage $V_{id} = -1\text{ V}$, $I_{OL} = +6\text{ mA}$ $T_{min.} \leq T_{amb} \leq T_{max.}$		400	550 800	mV
I_{CC}	Supply current (each comparator) No load - outputs low $T_{min.} \leq T_{amb} \leq T_{max.}$		9	20 25	μA
t_{PLH}	Response time low to high $V_{ic} = 0\text{ V}$, $f = 10\text{ kHz}$, $T_{min.} \leq T_{amb} \leq T_{max.}$, $C_L = 50\text{ pF}$, overdrive = 5 mV TTL input		1.5 0.7		μs
t_{PHL}	Response time high to low $V_{ic} = 0\text{ V}$, $f = 10\text{ kHz}$, $R_L = 5.1\text{ k}\Omega$, $C_L = 50\text{ pF}$, overdrive = 5 mV TTL input		2.5 0.08		

1. The specified offset voltage is the maximum value required to drive the output up to 2.5 V or down to 0.3 V.

2. Maximum values including unavoidable inaccuracies of the industrial test.

Table 4. $V_{CC}^+ = 5\text{ V}$, $V_{CC}^- = 0\text{ V}$, $T_{amb} = 25\text{ }^\circ\text{C}$ (unless otherwise specified)

Symbol	Parameter	Min.	Typ.	Max.	Unit
V_{io}	Input offset voltage ⁽¹⁾ $V_{ic} = 2.5\text{ V}$, $V_{CC}^+ = 5\text{ V to }10\text{ V}$ $T_{min.} \leq T_{amb} \leq T_{max.}$		1.4	5 6.5	mV
I_{io}	Input offset current ⁽²⁾ $V_{ic} = 2.5\text{ V}$ $T_{min.} \leq T_{amb} \leq T_{max.}$		1	300	pA
I_{ib}	Input bias current ⁽²⁾ $V_{ic} = 2.5\text{ V}$ $T_{min.} \leq T_{amb} \leq T_{max.}$		1	600	
V_{icm}	Input common mode voltage range $T_{min.} \leq T_{amb} \leq T_{max.}$	0 0		$V_{CC}^+ - 1.2$ $V_{CC}^+ - 1.5$	V
CMR	Common-mode rejection ratio $V_{ic} = 0\text{ V}$		75		dB
SVR	Supply voltage rejection ratio $V_{CC}^+ = +5\text{ V to }+10\text{ V}$		85		
I_{OH}	High level output voltage $V_{id} = 1\text{ V}$, $V_{OH} = +5\text{ V}$ $T_{min.} \leq T_{amb} \leq T_{max.}$		27	40 1000	nA
V_{OL}	Low level output voltage $V_{id} = -1\text{ V}$, $I_{OL} = 6\text{ mA}$ $T_{min.} \leq T_{amb} \leq T_{max.}$		260	400 650	mV
I_{CC}	Supply current (each comparator) No load - outputs low $T_{min.} \leq T_{amb} \leq T_{max.}$		10	20 25	μA
t_{PLH}	Response time low to high $V_{ic} = 0\text{ V}$, $f = 10\text{ kHz}$, $R_L = 5.1\text{ k}\Omega$, $C_L = 15\text{ pF}$, overdrive = 5 mV Overdrive = 10 mV Overdrive = 20 mV Overdrive = 40 mV TTL input		1.5 1.2 1.1 0.9 0.8		μs
t_{PHL}	Response time high to low $V_{ic} = 0\text{ V}$, $f = 10\text{ kHz}$, $R_L = 5.1\text{ k}\Omega$, $C_L = 15\text{ pF}$, overdrive = 5 mV Overdrive = 10 mV Overdrive = 20 mV Overdrive = 40 mV TTL input		2.5 1.9 1.2 0.8 0.08		
t_f	Fall time $f = 10\text{ kHz}$, $C_L = 50\text{ pF}$, $R_L = 5.1\text{ k}\Omega$, overdrive 50 mV		30		ns

1. The specified offset voltage is the maximum value required to drive the output up to 4.5 V or down to 0.3 V.
2. Maximum values including unavoidable inaccuracies of the industrial test.

4 Package information

In order to meet environmental requirements, ST offers these devices in different grades of ECOPACK® packages, depending on their level of environmental compliance. ECOPACK specifications, grade definitions and product status are available at: www.st.com. ECOPACK is an ST trademark.

4.1 SO14 package information

Figure 2. SO14 package outline

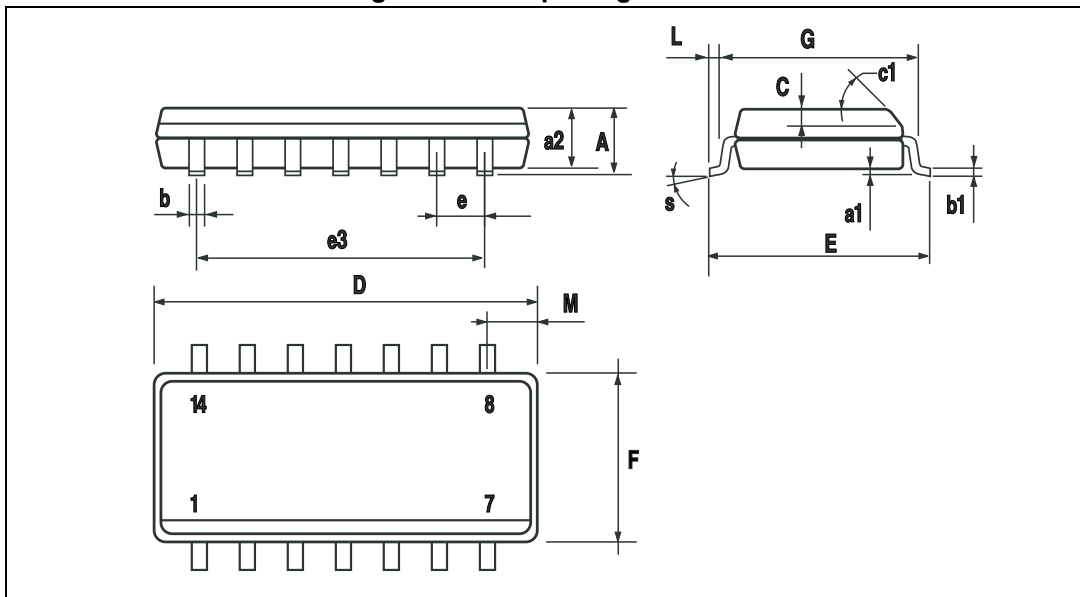

Table 5. SO14 package mechanical data

Symbol	Dimensions					
	mm			inch		
	Min.	Typ.	Max.	Min.	Typ.	Max.
A			1.75			0.068
a1	0.1		0.2	0.003		0.007
a2			1.65			0.064
b	0.35		0.46	0.013		0.018
b1	0.19		0.25	0.007		0.010
C		0.5			0.019	
c1	45° (typ.)					
D	8.55		8.75	0.336		0.344
E	5.8		6.2	0.228		0.244
e		1.27			0.050	
e3		7.62			0.300	
F	3.8		4.0	0.149		0.157
G	4.6		5.3	0.181		0.208
L	0.5		1.27	0.019		0.050
M			0.68			0.026
S	8° (max.)					

4.2 TSSOP14 package information

Figure 3. TSSOP14 package outline

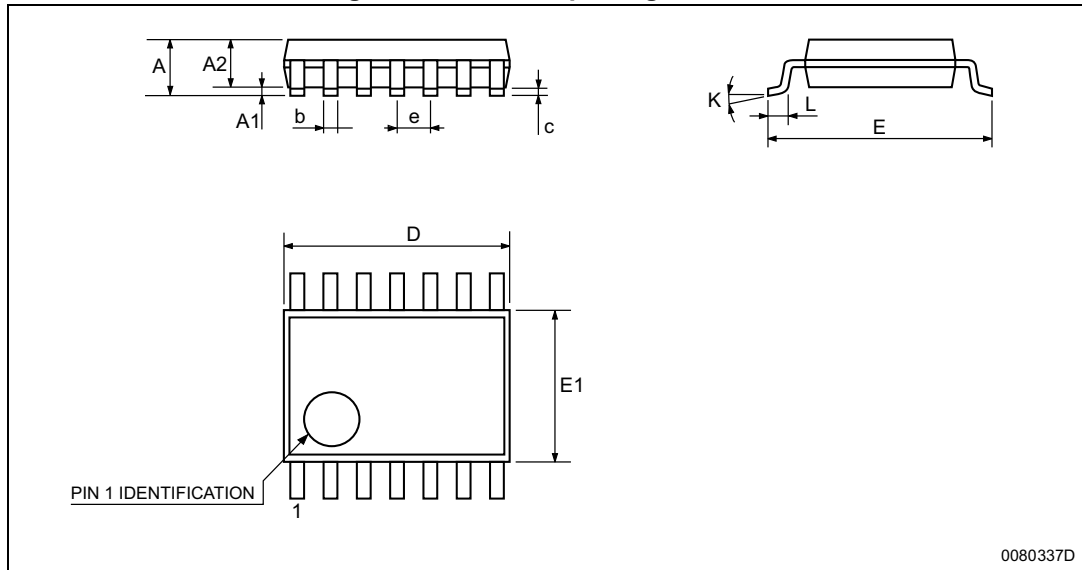

Table 6. TSSOP14 package mechanical data

Symbol	Dimensions					
	mm.			inch		
	Min.	Typ.	Max.	Min.	Typ.	Max.
A			1.2			0.047
A1	0.05		0.15	0.002	0.004	0.006
A2	0.8	1	1.05	0.031	0.039	0.041
b	0.19		0.30	0.007		0.012
c	0.09		0.20	0.004		0.0089
D	4.9	5	5.1	0.193	0.197	0.201
E	6.2	6.4	6.6	0.244	0.252	0.260
E1	4.3	4.4	4.48	0.169	0.173	0.176
e		0.65 BSC			0.0256 BSC	
K	0°		8°	0°		8°
L	0.45	0.60	0.75	0.018	0.024	0.030

5 Revision history

Table 7. Document revision history

Date	Revision	Changes
Jan. 2003	1	Initial release.
Aug. 2005	2	1 - PPAP references inserted in the datasheet see Table 1: Order codes on page 1 . 2 - ESD protection inserted in Table 2 Key parameters and their absolute maximum ratings on page 2 .
04-Sep-2012	3	Updated Features, Table 1 , removed TS339IYD and TS339IYDT from Table 1 . Updated ECOPACK text, reformatted Section 4: Package information . Minor corrections throughout document.
21-Feb-2014	4	Removed DIP package Features : updated fast response time Device summary : removed order codes TS339CN, TS339IN, and TS339ID; added temperature range for order codes TS339IDT and TS339IPT

Please Read Carefully:

Information in this document is provided solely in connection with ST products. STMicroelectronics NV and its subsidiaries ("ST") reserve the right to make changes, corrections, modifications or improvements, to this document, and the products and services described herein at any time, without notice.

All ST products are sold pursuant to ST's terms and conditions of sale.

Purchasers are solely responsible for the choice, selection and use of the ST products and services described herein, and ST assumes no liability whatsoever relating to the choice, selection or use of the ST products and services described herein.

No license, express or implied, by estoppel or otherwise, to any intellectual property rights is granted under this document. If any part of this document refers to any third party products or services it shall not be deemed a license grant by ST for the use of such third party products or services, or any intellectual property contained therein or considered as a warranty covering the use in any manner whatsoever of such third party products or services or any intellectual property contained therein.

UNLESS OTHERWISE SET FORTH IN ST'S TERMS AND CONDITIONS OF SALE ST DISCLAIMS ANY EXPRESS OR IMPLIED WARRANTY WITH RESPECT TO THE USE AND/OR SALE OF ST PRODUCTS INCLUDING WITHOUT LIMITATION IMPLIED WARRANTIES OF MERCHANTABILITY, FITNESS FOR A PARTICULAR PURPOSE (AND THEIR EQUIVALENTS UNDER THE LAWS OF ANY JURISDICTION), OR INFRINGEMENT OF ANY PATENT, COPYRIGHT OR OTHER INTELLECTUAL PROPERTY RIGHT.

ST PRODUCTS ARE NOT DESIGNED OR AUTHORIZED FOR USE IN: (A) SAFETY CRITICAL APPLICATIONS SUCH AS LIFE SUPPORTING, ACTIVE IMPLANTED DEVICES OR SYSTEMS WITH PRODUCT FUNCTIONAL SAFETY REQUIREMENTS; (B) AERONAUTIC APPLICATIONS; (C) AUTOMOTIVE APPLICATIONS OR ENVIRONMENTS, AND/OR (D) AEROSPACE APPLICATIONS OR ENVIRONMENTS. WHERE ST PRODUCTS ARE NOT DESIGNED FOR SUCH USE, THE PURCHASER SHALL USE PRODUCTS AT PURCHASER'S SOLE RISK, EVEN IF ST HAS BEEN INFORMED IN WRITING OF SUCH USAGE, UNLESS A PRODUCT IS EXPRESSLY DESIGNATED BY ST AS BEING INTENDED FOR "AUTOMOTIVE, AUTOMOTIVE SAFETY OR MEDICAL" INDUSTRY DOMAINS ACCORDING TO ST PRODUCT DESIGN SPECIFICATIONS. PRODUCTS FORMALLY ESCC, QML OR JAN QUALIFIED ARE DEEMED SUITABLE FOR USE IN AEROSPACE BY THE CORRESPONDING GOVERNMENTAL AGENCY.

Resale of ST products with provisions different from the statements and/or technical features set forth in this document shall immediately void any warranty granted by ST for the ST product or service described herein and shall not create or extend in any manner whatsoever, any liability of ST.

ST and the ST logo are trademarks or registered trademarks of ST in various countries.

Information in this document supersedes and replaces all information previously supplied.

The ST logo is a registered trademark of STMicroelectronics. All other names are the property of their respective owners.

© 2014 STMicroelectronics - All rights reserved

STMicroelectronics group of companies

Australia - Belgium - Brazil - Canada - China - Czech Republic - Finland - France - Germany - Hong Kong - India - Israel - Italy - Japan - Malaysia - Malta - Morocco - Philippines - Singapore - Spain - Sweden - Switzerland - United Kingdom - United States of America

www.st.com



Компания «Life Electronics» занимается поставками электронных компонентов импортного и отечественного производства от производителей и со складов крупных дистрибьюторов Европы, Америки и Азии.

С конца 2013 года компания активно расширяет линейку поставок компонентов по направлению коаксиальный кабель, кварцевые генераторы и конденсаторы (керамические, пленочные, электролитические), за счёт заключения дистрибьюторских договоров

Мы предлагаем:

- Конкурентоспособные цены и скидки постоянным клиентам.
- Специальные условия для постоянных клиентов.
- Подбор аналогов.
- Поставку компонентов в любых объемах, удовлетворяющих вашим потребностям.
- Приемлемые сроки поставки, возможна ускоренная поставка.
- Доставку товара в любую точку России и стран СНГ.
- Комплексную поставку.
- Работу по проектам и поставку образцов.
- Формирование склада под заказчика.
- Сертификаты соответствия на поставляемую продукцию (по желанию клиента).
- Тестирование поставляемой продукции.
- Поставку компонентов, требующих военную и космическую приемку.
- Входной контроль качества.
- Наличие сертификата ISO.

В составе нашей компании организован Конструкторский отдел, призванный помогать разработчикам, и инженерам.

Конструкторский отдел помогает осуществить:

- Регистрацию проекта у производителя компонентов.
- Техническую поддержку проекта.
- Защиту от снятия компонента с производства.
- Оценку стоимости проекта по компонентам.
- Изготовление тестовой платы монтаж и пусконаладочные работы.



Тел: +7 (812) 336 43 04 (многоканальный)

Email: org@lifeelectronics.ru