

**LED DISPLAY****LTS-4817SW-P**  
**DATA SHEET**

<b><u>ITEM</u></b>	<b><u>Description</u></b>	<b><u>By</u></b>	<b><u>DATE</u></b>
1	New Spec	Reo Lin	2011/08/24

**FEATURES**

- \* 0.39 inch (10.0 mm) DIGIT HEIGHT
- \* CONTINUOUS UNIFORM SEGMENTS
- \* LOW POWER REQUIREMENT
- \* EXCELLENT CHARACTERS APPEARANCE
- \* HIGH BRIGHTNESS & HIGH CONTRAST
- \* WIDE VIEWING ANGLE
- \* SOLID STATE RELIABILITY
- \* CATEGORIZED FOR LUMINOUS INTENSITY
- \* SMD DISPLAY
- \* **LEAD FREE PACKAGE (ACCORDING TO ROHS)**

**DESCRIPTION**

The LTS-4817SW-P is a 0.39 inch (10.0 mm) digit height single digit SMD display. This device uses LTW-C193 series InGaN white Chip LED. The display has gray face and white segments, and suitable for reverse mount assembly.

**DEVICE**

<b>PART NO.</b>	<b>DESCRIPTION</b>
InGaN White	Common Anode
LTS-4817SW-P	

**PACKAGE DIMENSIONS**

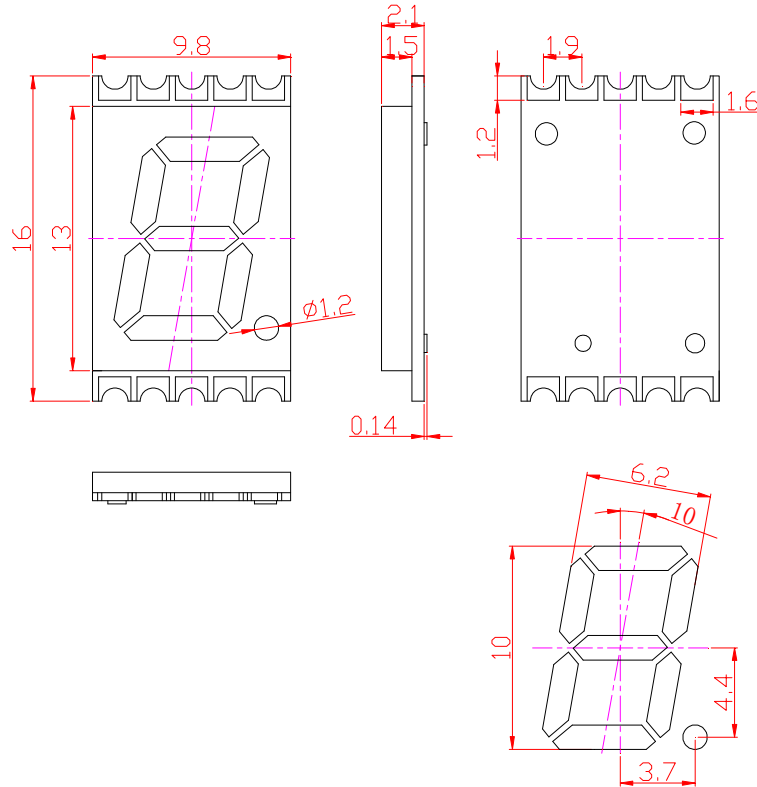

**Solder Pad Vs Painting Diagram**

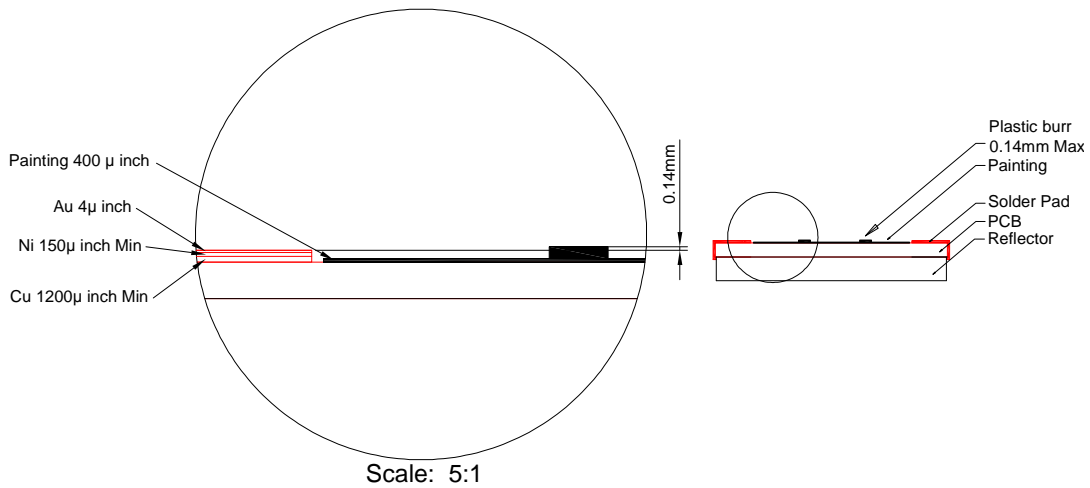

**NOTES:**

1. Plastic pins' burr max. 0.14 mm,
2. All dimensions are in millimeters. Tolerances are  $\pm 0.25\text{mm}$  (0.01") unless otherwise noted.
3. Solder pad materials and thickness: Cu:  $1200\ \mu$  inch Ni: Min  $150\ \mu$  inch Au:  $4\ \mu$  inch.

**INTERNAL CIRCUIT DIAGRAM**

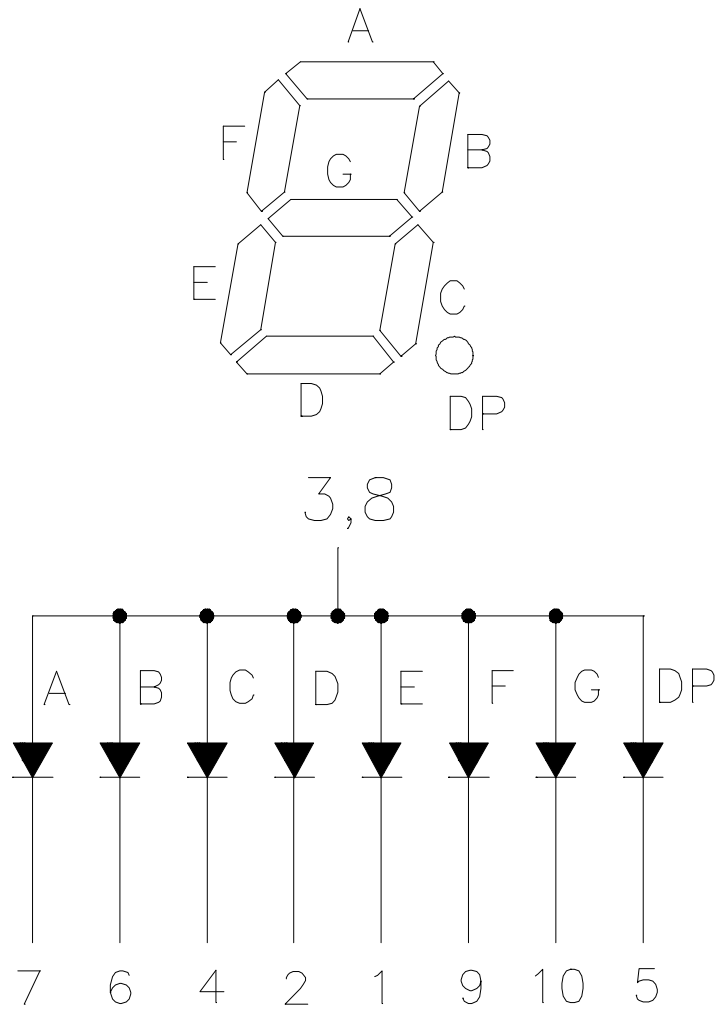

**PIN CONNECTION**

<b>No.</b>	<b>CONNECTION</b>
1	CATHODE E
2	CATHODE D
3	COMMON ANODE
4	CATHODE C
5	CATHODE D.P.
6	CATHODE B
7	CATHODE A
8	COMMON ANODE
9	CATHODE F
10	CATHODE G

## ABSOLUTE MAXIMUM RATING AT Ta = 25°C

PARAMETER	MAXIMUM RATING	UNIT
Power Dissipation Per Segment	70	mW
Peak Forward Current Per Segment (Frequency 1Khz,10% duty cycle )	100	mA
Continuous Forward Current Per Segment	20	mA
Forward Current Derating from 25 °C	0.25	mA/°C
Operating Temperature Range	-35 °C to +80 °C	
Storage Temperature Range	-55 °C to +105 °C	
Iron Soldering Conditions: 1/16 inch Below Seating Plane for 3 Seconds at 260 °C		

## ELECTRICAL / OPTICAL CHARACTERISTICS AT Ta = 25°C

PARAMETER	SYMBOL	MIN.	TYP.	MAX.	UNIT	TEST CONDITION
Luminous Intensity	IV	28.0	44.0		mcd	IF = 5mA Note 1, 2, 5
Chromaticity Coordinates	x		0.294			IF = 5mA Note 3, 5
	y		0.286			
Forward Voltage Per Segment	V <sub>F</sub>	2.70		3.2	V	IF = 5mA
Reverse Current Per Segment	I <sub>R</sub>			100	μA	V <sub>R</sub> =5V Note 7

Note:

- Luminous intensity is measured with a light sensor and filter combination that approximates the CIE (Commision Internationale De L'Eclairage) eye-response curve.
- Iv classification code is marked on each packing bag.
- The chromaticity coordinates (x, y) is derived from the 1931 CIE chromaticity diagram.
- Caution in ESD:  
Static Electricity and surge damages the LED. It is recommend using a wrist band or anti-electrostatic glove when handling the LED. All devices, equipment and machinery must be properly grounded.
- Tester: CAS140B is for the chromaticity coordinates (x, y) and IV.
- The chromaticity coordinates (x, y) guarantee should be added ± 0.01 tolerance.
- Reverse voltage is only for IR test. It can not continue to operate at this situation.

## Chip LED Bin Code List

<b>V<sub>F</sub> Spec. Table</b>		
V <sub>F</sub> Bin	Forward Voltage (V) at I <sub>F</sub> =5mA	
	Min.	Max
3	2.7	2.8
4	2.8	2.9
5	2.9	3.0
6	3.0	3.1
7	3.1	3.2

Tolerance on each Forward Voltage bin is +/-0.1 volt

<b>I<sub>v</sub> Spec. Table</b>		
I <sub>v</sub> Bin	I <sub>v</sub> (mcd) at I <sub>F</sub> =5mA	
	Min.	Max.
Q11	71.0	81.0
Q12	81.0	90.0
Q21	90.0	101.0
Q22	101.0	112.0
R11	112.0	129.0
R12	129.0	146.0
R21	146.0	165.0

Tolerance on each Luminous Intensity bin is +/-10%

<b>Color Ranks Table</b>					
Ranks	Color bin limits at I <sub>F</sub> =5mA				
	CIE 1931 Chromaticity coordinates				
		x	y	z	w
S1-2	x	0.284	0.284	0.294	0.294
	y	0.240	0.272	0.286	0.254
S2-2	x	0.284	0.284	0.294	0.294
	y	0.272	0.305	0.319	0.286
S3-1	x	0.294	0.294	0.304	0.304
	y	0.254	0.286	0.300	0.268

## Property of Lite-On Only

S3-2	x	0.304	0.304	0.314	0.314
	y	0.268	0.300	0.315	0.282
S4-1	x	0.294	0.294	0.304	0.304
	y	0.286	0.319	0.333	0.300
S4-2	x	0.304	0.304	0.314	0.314
	y	0.300	0.333	0.347	0.315
S5-1	x	0.314	0.314	0.324	0.324
	y	0.282	0.315	0.329	0.296
S6-1	x	0.314	0.314	0.324	0.324
	y	0.315	0.347	0.361	0.329

Tolerance on each Hue (x,y) bin is +/- 0.01

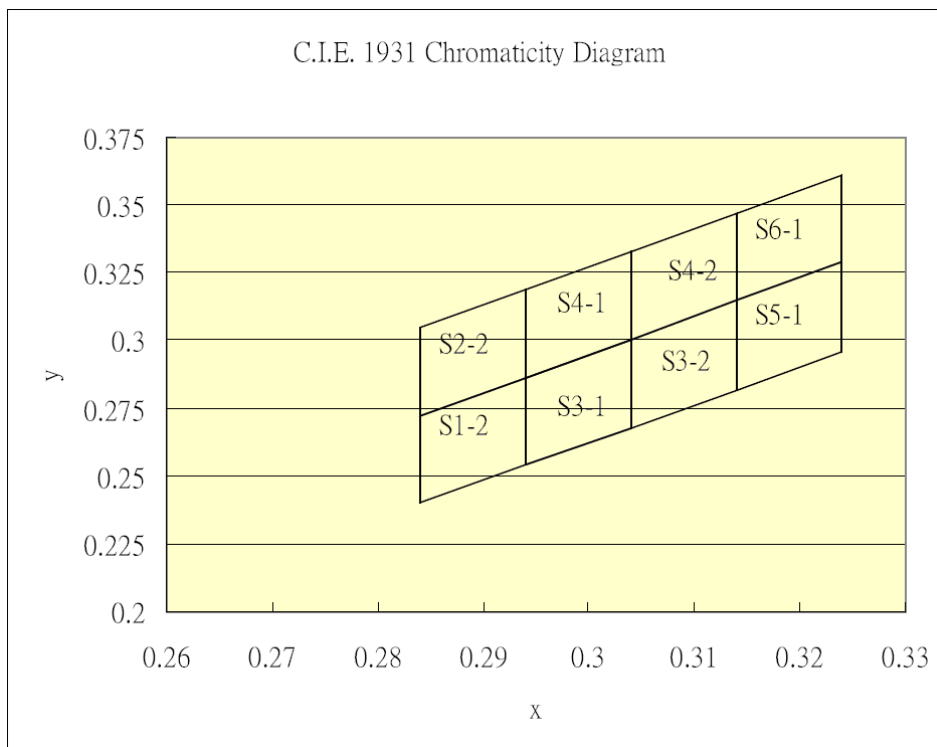



**TYPICAL ELECTRICAL / OPTICAL CHARACTERISTIC CURVES**

(25°C Ambient Temperature Unless Otherwise Noted)

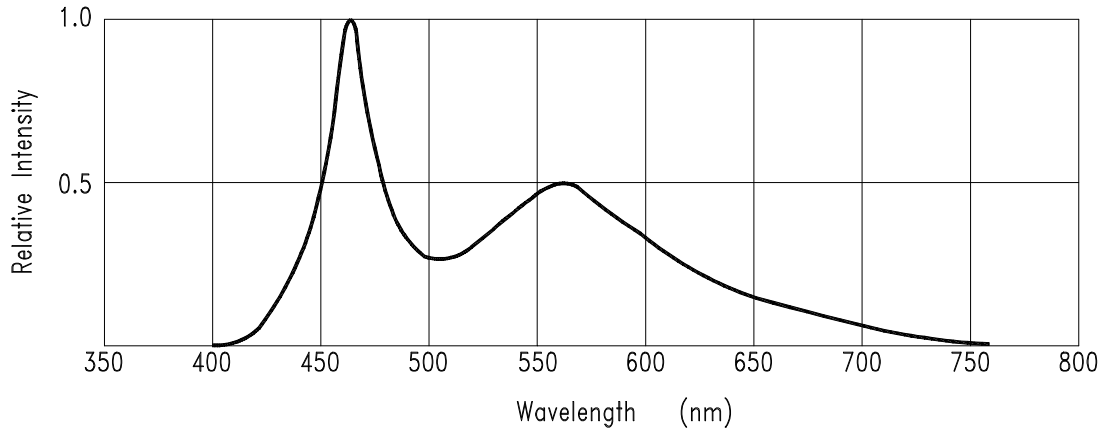

Fig.1 RELATIVE INTENSITY VS. WAVELENGTH

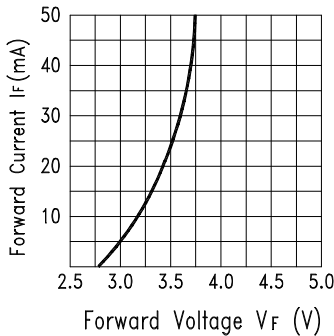

Fig.2 Forward Current vs. Forward Voltage

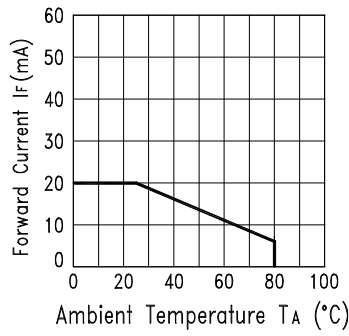

Fig.3 Forward Current Derating Curve

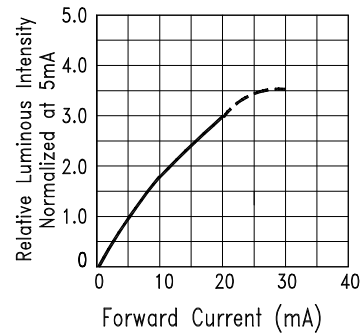

Fig.4 Relative Luminous Intensity vs. Forward Current

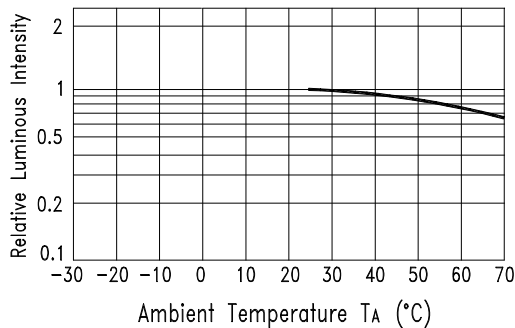

Fig.5 Luminous Intensity vs. Ambient Temperature

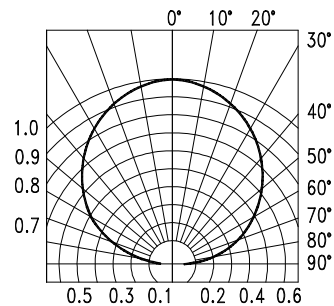
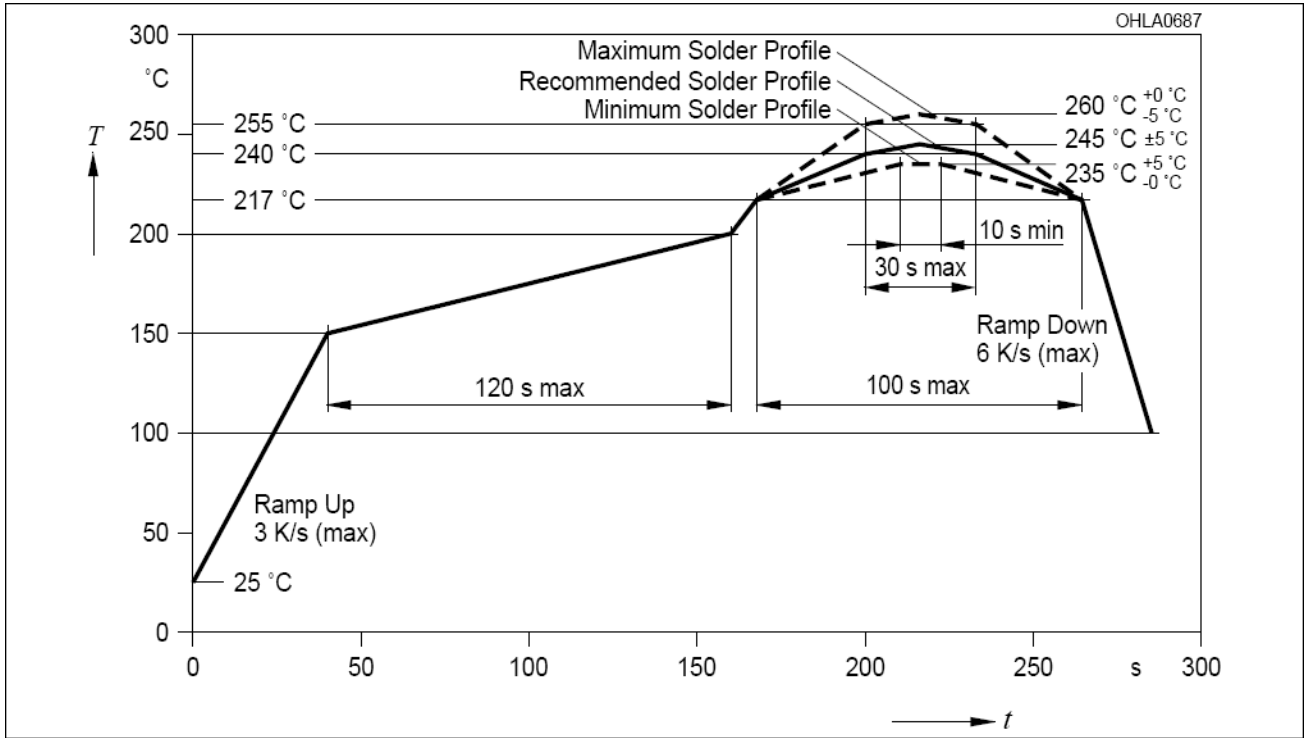

Fig.6 Spatial Distribution

**SMT SOLDERING INSTRUCTION**



Note:

1. Recommended soldering condition:

<b>Reflow Soldering (Two times only)</b>		<b>Soldering Iron (One time only)</b>	
Pre-heat:	120~150°C.	Temperature	300°C Max.
Pre-heat time:	120sec. Max.	Soldering time	3sec. Max.
Peak temperature:	260°C Max.		
Soldering time:	5sec. Max.		

2. Number of reflow process shall be less than 2 times, and cooling process to normal temperature is required between the first and the second soldering process.

## RECOMMENDED SOLDERING PATTERN

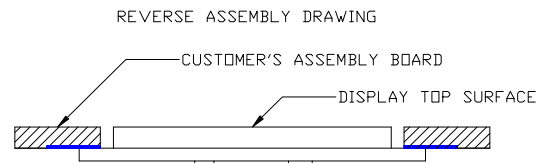
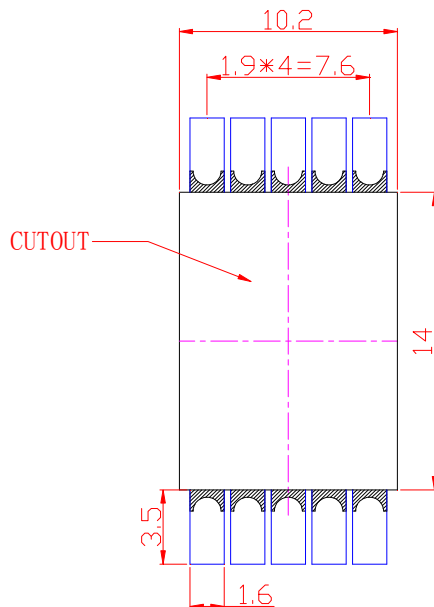

Note: All dimensions are in millimeters.

## PACKING REEL DIMENSIONS

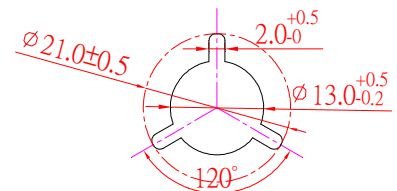
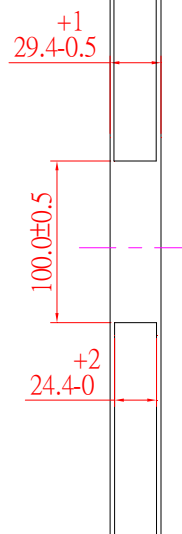
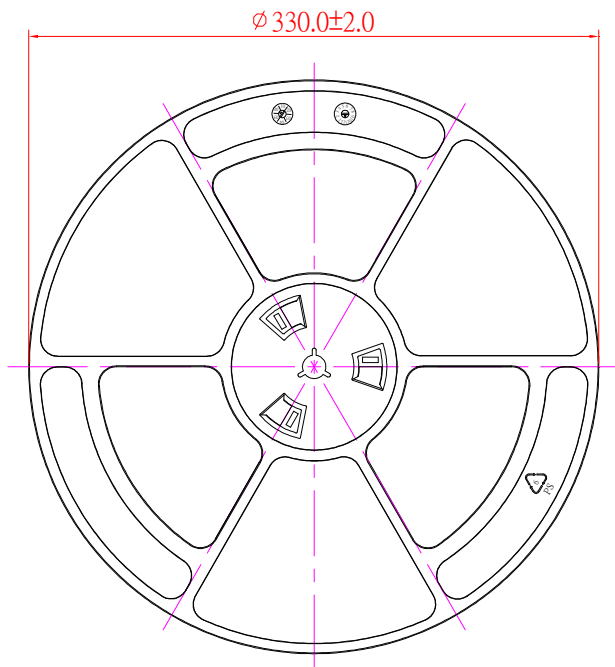

## PACKING CARRIER DIMENSIONS

### 1. Taping parts:

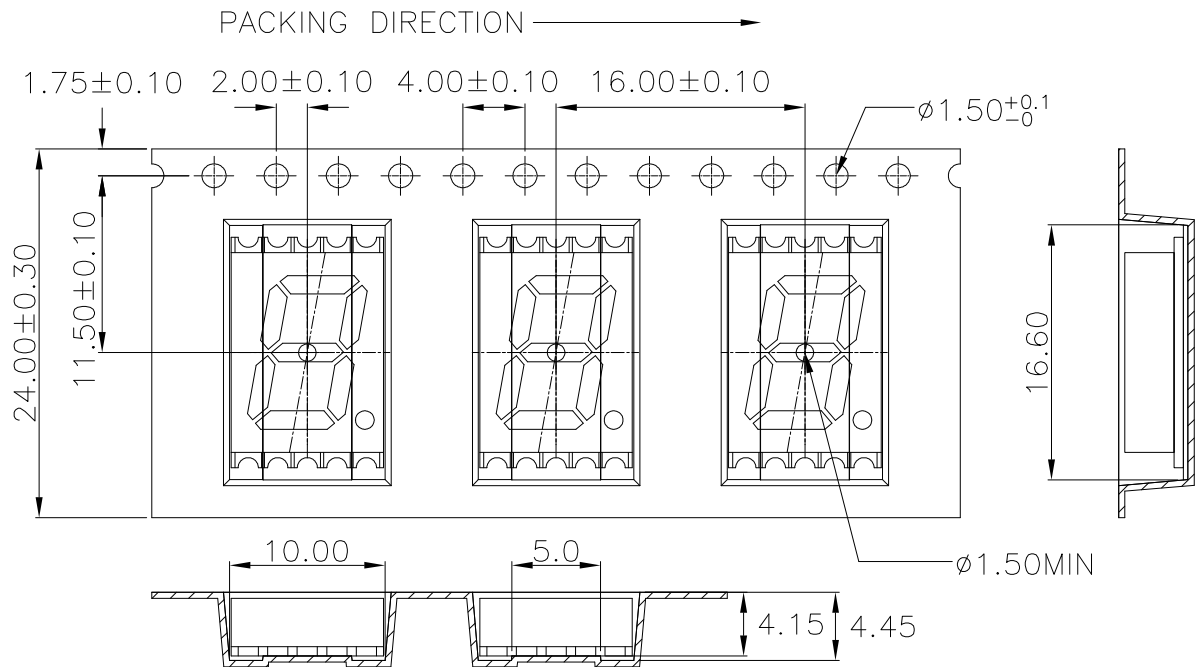

10 sprocket hole pitch cumulative tolerance  $\pm 0.20$ .  
 Carrier camber is within 1 mm in 250 mm.  
 Thickness :  $0.40 \pm 0.05 \text{ mm}$ .  
 All dimensions meet EIA-481-C requirements.

### 2. Trailer part/ Leader part:

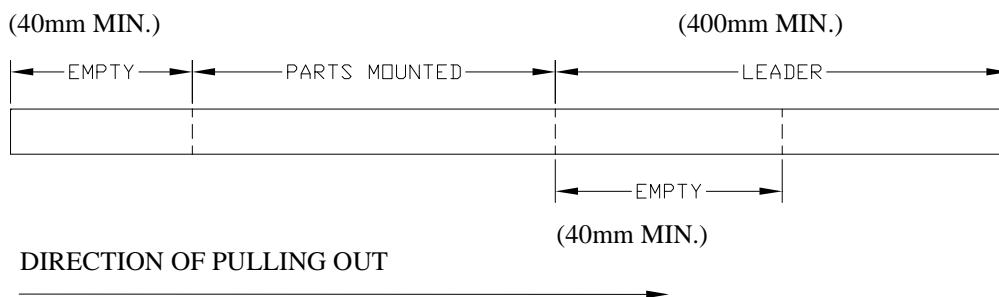

**Moisture Proof Packaging**

All N/D SMD displays are shipped in moisture proof package. The displays should be stored at 30°C or less and 90% RH or less. Once the package opened, moisture absorption begins.

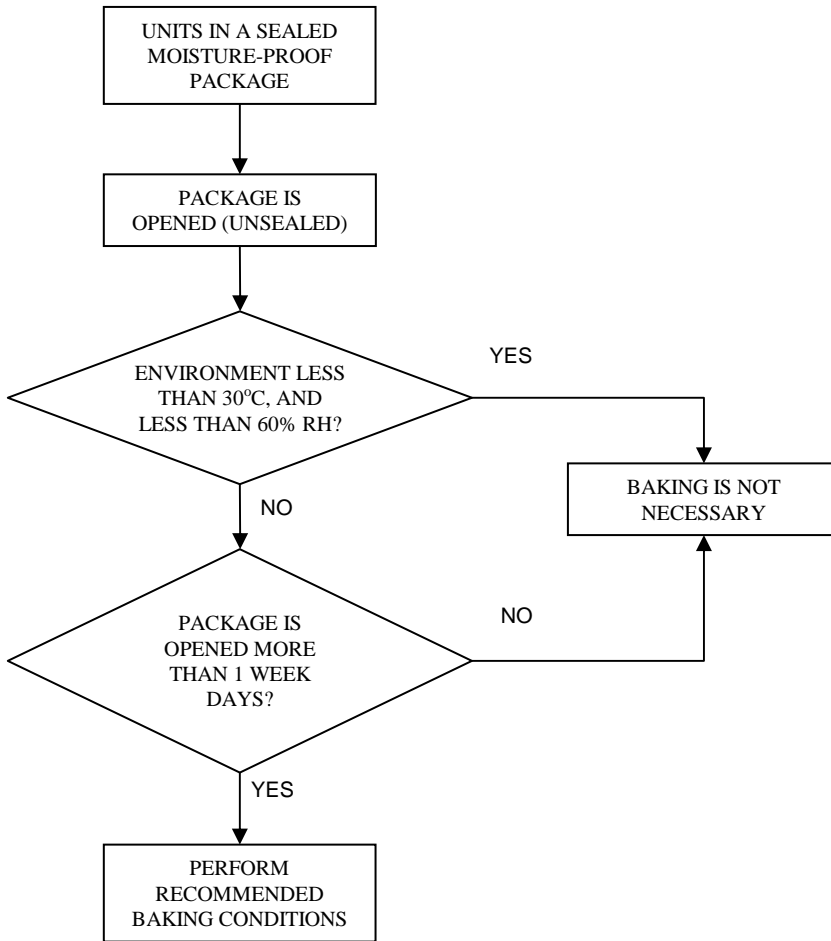

**Baking Conditions**

If the parts are not stored in dry conditions, they must be baked before reflow to prevent damage to the parts.

Package	Temperature	Time
In Reel	60°C	≥ 48hours
In Bulk	100°C	≥ 4hours
	125°C	≥ 2hours

**Baking should only be done once.**

Компания «Life Electronics» занимается поставками электронных компонентов импортного и отечественного производства от производителей и со складов крупных дистрибьюторов Европы, Америки и Азии.

С конца 2013 года компания активно расширяет линейку поставок компонентов по направлению коаксиальный кабель, кварцевые генераторы и конденсаторы (керамические, пленочные, электролитические), за счёт заключения дистрибьюторских договоров

Мы предлагаем:

- Конкурентоспособные цены и скидки постоянным клиентам.
- Специальные условия для постоянных клиентов.
- Подбор аналогов.
- Поставку компонентов в любых объемах, удовлетворяющих вашим потребностям.
- Приемлемые сроки поставки, возможна ускоренная поставка.
- Доставку товара в любую точку России и стран СНГ.
- Комплексную поставку.
- Работу по проектам и поставку образцов.
- Формирование склада под заказчика.
- Сертификаты соответствия на поставляемую продукцию (по желанию клиента).
- Тестирование поставляемой продукции.
- Поставку компонентов, требующих военную и космическую приемку.
- Входной контроль качества.
- Наличие сертификата ISO.

В составе нашей компании организован Конструкторский отдел, призванный помогать разработчикам, и инженерам.

Конструкторский отдел помогает осуществить:

- Регистрацию проекта у производителя компонентов.
- Техническую поддержку проекта.
- Защиту от снятия компонента с производства.
- Оценку стоимости проекта по компонентам.
- Изготовление тестовой платы монтаж и пусконаладочные работы.



Тел: +7 (812) 336 43 04 (многоканальный)

Email: [org@lifeelectronics.ru](mailto:org@lifeelectronics.ru)