



Main

Range of product	Magelis iPC
Product or component type	Multi-touch screen
Processor name	Intel Atom E3827 dual core 1.75 GHz
Chipset type	Intel Atom SoC
Free slots	1 CFast
Display size	10.1 inch
Display colour	267000 colours
Luminance	27.87 fc (300 cd/m ²)
Pixel resolution	4096 x 4096
Video controller type	Intel HD Graphics
Software package	EcoStruxure secure connect advisor annual subscription cyber security license not included EcoStruxure operator terminal expert run time HMI license not included EcoStruxure machine SCADA expert run time HMI/SCADA on configured offer only EcoStruxure augmented operator advisor server augmented operator license not included

Complementary

Number of points	5
Terminal type	Touchscreen display
Memory type	RAM DDR3 4 GB internal
Data storage equipment	CFast card
Aspect ratio	16:9
Display type	LED Colour TFT LCD
Display resolution	1280 x 800 pixels WSVGA
Backlight lifespan	50000 hours
View angle horizontal x vertical	160 x 160°
Touch panel	Projected capacitive technology (PCT)
Type of cooling	Fanless Passive
Watchdog timer	1...255 ms
Integrated connection type	RS232 with 1 male SUB-D 9, transmission rate: <= 115.2 kbits/s RS485/RS422 with 1 male SUB-D 9, transmission rate: <= 115.2 kbits/s USB 3.0 type A with 1, transmission rate: 1.5/12/480 Mbit/s, 5 Gbit/s USB 2.0 type A with 1, transmission rate: 1.5/12/480 Mbit/s Ethernet port with 2 RJ45, transmission rate: 10/100/1000 Mbit/s
[Us] rated supply voltage	24 V DC +/- 20 % 100...240 V AC with additional adaptor HMIYPSOMAC1
Line Rated Current	1.9 A
Mechanical robustness	7H hardness anti-scratch
Local signalling	Buzzer Green LED on Orange LED stand-by
Function available	Operate with water on screen
Width	11.15 in (283.1 mm)
Height	7.96 in (202.3 mm)
Depth	2.41 in (61.3 mm)
Cut-out dimensions	274.6 (+/- 0.7) x 193.8 (+/- 0.4)
Product weight	5.51 lb(US) (2.5 kg)
Main type	Optimised

The information provided in this documentation contains general descriptions and/or technical characteristics of the performance of the products contained herein. This documentation is not intended as a substitute for and is not to be used for determining suitability or reliability of these products for specific user applications. It is the duty of any such user or integrator to perform the appropriate and complete risk analysis, evaluation and testing of the products with respect to the relevant specific application or use thereof. Neither Schneider Electric Industries SAS nor any of its affiliates or subsidiaries shall be responsible or liable for misuse of the information contained herein.

Environment

IP degree of protection	IP66 front panel
product certifications	AS/NZS CCC CE C-Tick RCM EAC
standards	CISPR 11 IEC 60950 IEC 61000-6-2 IEC 61000-6-4 UL 60950 FCC part 15 class A CSA C22.2 No 60950
directives	2004/108/EC - electromagnetic compatibility 2006/95/EC - low voltage directive 2011/65/EU - RoHS directive 1907/2006/EC - REACH directive 2012/19/EU - WEEE directive
pollution degree	2
ambient air temperature for operation	0...55 °C SSD 0...55 °C Cfast card 0...45 °C HDD 0...45 °C Mini PCIe
ambient air temperature for storage	-4...140 °F (-20...60 °C)
relative humidity	10...95 % non-condensing
operating altitude	2000
vibration resistance	1 gn 5...500 Hz HDD 2 gn 5...500 Hz SSD 2 gn 5...500 Hz Cfast card

Offer Sustainability

Not Green Premium product	Not Green Premium product
Compliant - since 1604 - Schneider Electric declaration of conformity	Compliant - since 1604 - Schneider Electric declaration of conformity
Reference not containing SVHC above the threshold	Reference not containing SVHC above the threshold
WARNING: Cancer and Reproductive Harm - www.P65Warnings.ca.gov	WARNING: Cancer and Reproductive Harm - www.P65Warnings.ca.gov

Dimensions

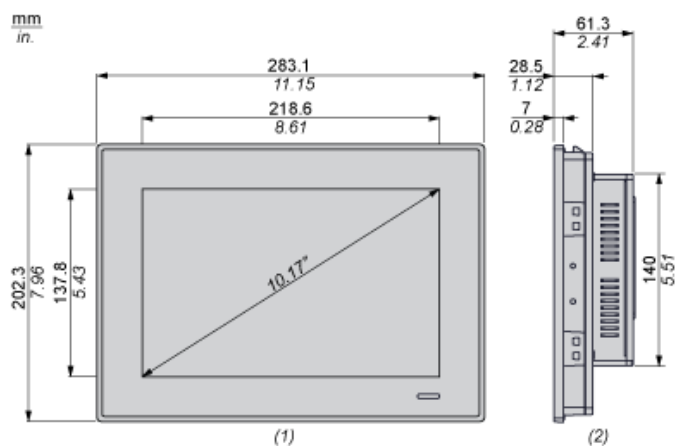

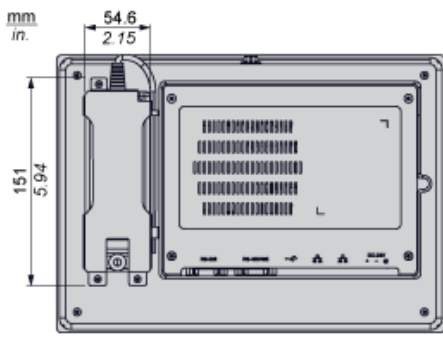

(3)

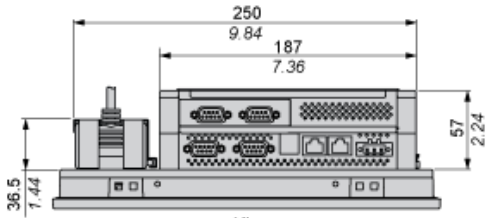

(4)

- (1) Front view
- (2) Right view
- (3) Back view
- (4) Bottom view

Spacing Requirements

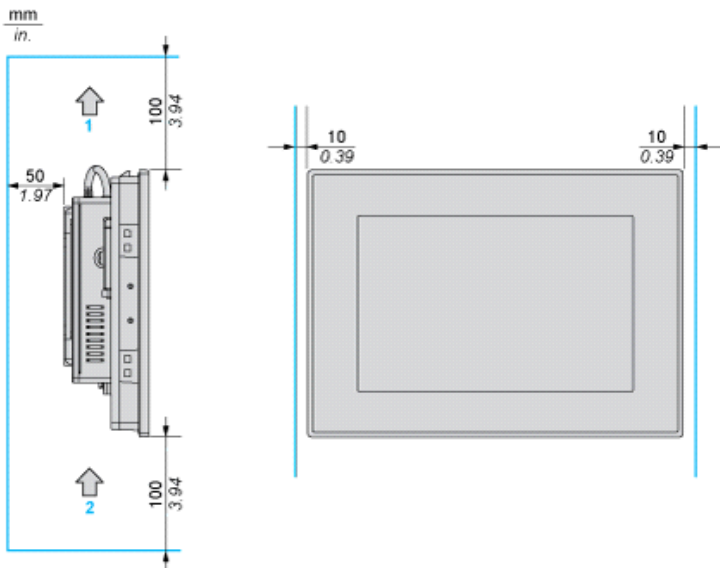

- 1 : Air out
- 2 : Air in

Mounting Orientation



Panel Cut Dimensions

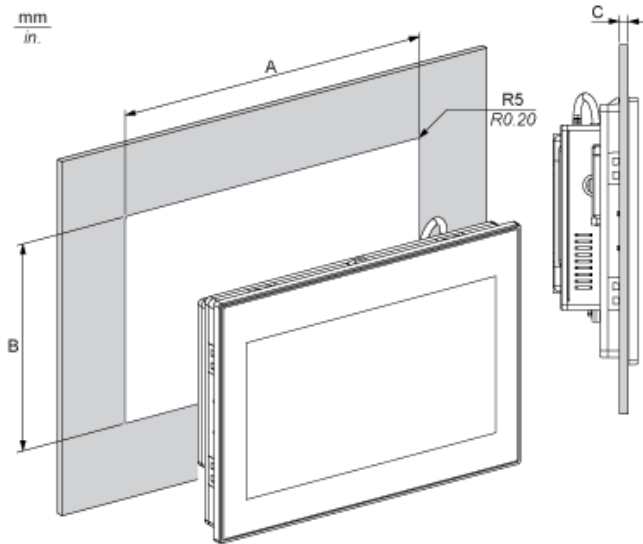

A		B		C		R	
mm	in.	mm	in.	mm	in.	mm	in.
274.6	10.81	193.8	7.63	2...6	0.08...0.23	5	0.20

Компания «Life Electronics» занимается поставками электронных компонентов импортного и отечественного производства от производителей и со складов крупных дистрибьюторов Европы, Америки и Азии.

С конца 2013 года компания активно расширяет линейку поставок компонентов по направлению коаксиальный кабель, кварцевые генераторы и конденсаторы (керамические, пленочные, электролитические), за счёт заключения дистрибьюторских договоров

Мы предлагаем:

- Конкурентоспособные цены и скидки постоянным клиентам.
- Специальные условия для постоянных клиентов.
- Подбор аналогов.
- Поставку компонентов в любых объемах, удовлетворяющих вашим потребностям.
- Приемлемые сроки поставки, возможна ускоренная поставка.
- Доставку товара в любую точку России и стран СНГ.
- Комплексную поставку.
- Работу по проектам и поставку образцов.
- Формирование склада под заказчика.
- Сертификаты соответствия на поставляемую продукцию (по желанию клиента).
- Тестирование поставляемой продукции.
- Поставку компонентов, требующих военную и космическую приемку.
- Входной контроль качества.
- Наличие сертификата ISO.

В составе нашей компании организован Конструкторский отдел, призванный помогать разработчикам, и инженерам.

Конструкторский отдел помогает осуществить:

- Регистрацию проекта у производителя компонентов.
- Техническую поддержку проекта.
- Защиту от снятия компонента с производства.
- Оценку стоимости проекта по компонентам.
- Изготовление тестовой платы монтаж и пусконаладочные работы.



Тел: +7 (812) 336 43 04 (многоканальный)
Email: org@lifeelectronics.ru