

High Performance Differential Fanout Buffer

Features

- 6 differential outputs with 2 banks
- User configurable output signaling standard for each bank: LVDS or LVPECL or HCSL
- Up to 1.5GHz output frequency for differential outputs
- Ultra low additive phase jitter: < 0.03 ps (typ) (differential 156.25MHz, 12KHz to 20MHz integration range)
- Selectable reference inputs support either single-ended or differential or Xtal
- Low skew between outputs within banks (<40ps)
- Low delay from input to output (Tpd typ. 1.5ns)
- Separate Input output supply voltage for level shifting
- 2.5V / 3.3V power supply
- Industrial temperature support
- TQFP-32 package

Description

The PI6C49S1506 is a high performance fanout buffer device which supports up to 1.5GHz frequency. It also integrates a unique feature with user configurable output signaling standards on per bank basis which provide great flexibilities to users. The device also uses Pericom's proprietary input detection technique to make sure illegal input conditions will be detected and reflected by output states. This device is ideal for systems that need to distribute low jitter clock signals to multiple destinations.

Applications

- Networking systems including switches and Routers
- High frequency backplane based computing and telecom platforms

Block Diagram

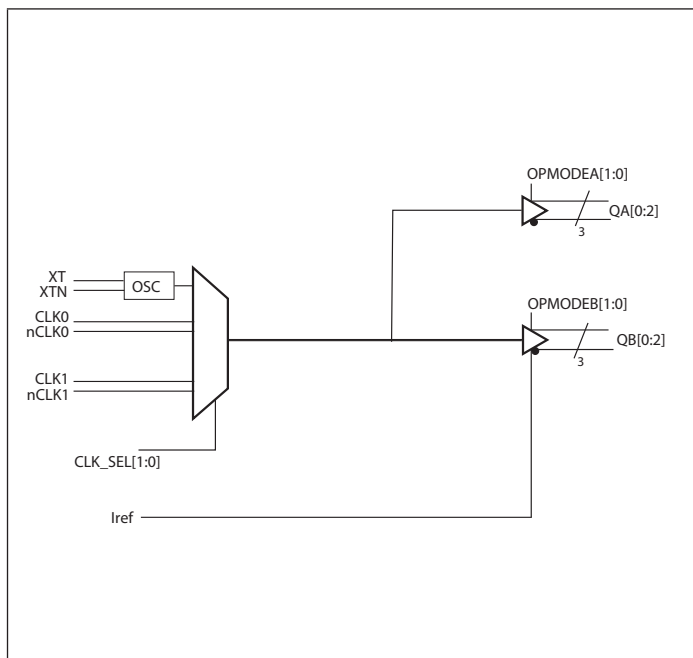

Pin Configuration (32-Pin TQFP)

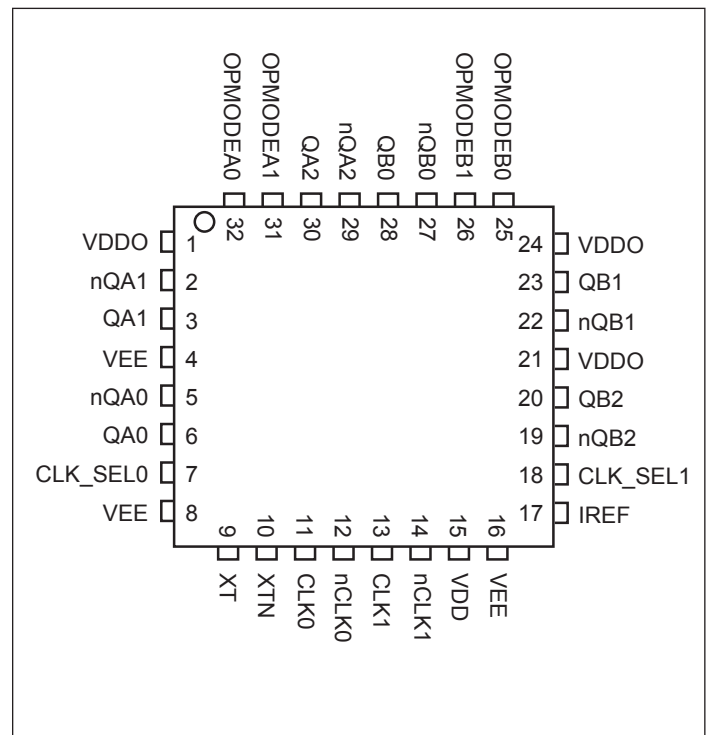

Pinout Table

Pin #	Pin Name	Type	Description
1, 21, 24	V _{DDO}	Power	Power supply pins for outputs
2,3	nQA1 QA1	Output	Bank A differential output pair 1. Pin selectable LVPECL/LVDS/HCSL interface levels.
4, 16	V _{EE}	Power	Connect to Negative power supply
5, 6	nQA0 QA0	Output	Bank A differential output pair 0. Pin selectable LVPECL/LVDS/HCSL interface levels.
7	CLK_SEL0	Input	Input clock source selection
8	V _{EE}	Power	Negative power supply
9	XT	Input	XTAL input
10	XTN	Output	XTAL output
11, 12	CLK0	Input	Differential clock input
	nCLK0	Input	Differential clock input
13, 14	CLK1	Input	Differential clock input
	nCLK1	Input	Differential clock input
15	V _{DD}	Power	Power supply pins for device core
17	IREF	Output	Reference current
18	CLK_SEL1	Input	Input clock source selection
19, 20	QB2 nQB2	Output	Bank B differential output pair 5. Pin selectable LVPECL/LVDS/HCSL interface levels.
22, 23	nQB1 QB1	Output	Bank B differential output pair 4. Pin selectable LVPECL/LVDS/HCSL interface levels.
25	OPMODEB0	Input	Bank B output selection pin
26	OPMODEB1	Input	Bank B output selection pin
27, 28	nQB0 QB0	Output	Bank B differential output pair 3. Pin selectable LVPECL/LVDS/HCSL interface levels.
29, 30	nQA2 QA2	Output	Bank A differential output pair 2. Pin selectable LVPECL/LVDS/HCSL interface levels.
31	OPMODEA1	Input	Bank A output selection pin
32	OPMODEA0	Input	Bank A output selection pin

Function Table

Table 1: Input select function

CLK_SEL [1]	CLK_SEL [0]	Function
0	0	XTAL is the selected input
0	1	CLK0 is the selected reference input
1	X	CLK1 is the selected reference input

Table 2: Output Mode select function

OPMODEA/B [1]	OPMODEA/B [0]	Output Bank A / Bank B Mode
0	0	LVPECL
0	1	LVDS
1	0	HCSL
1	1	Hi-Z

Maximum Ratings (Above which the useful life may be impaired. For user guidelines, not tested)

Storage temperature.....	-55 to +150°C
Supply Voltage to Ground Potential (VDD)	-0.5 to +4.6V
Inputs (Referenced to GND)	-0.5 to VDD+0.5V
Clock Output (Referenced to GND).....	-0.5 to VDD+0.5V
Soldering Temperature (Max of 10 seconds)	+260°C
Latch up	200mA
ESD Protection (Input)	2000 V min (HBM)

Note:

Stresses greater than those listed under MAXIMUM RATINGS may cause permanent damage to the device. This is a stress rating only and functional operation of the device at these or any other conditions above those indicated in the operational sections of this specification is not implied. Exposure to absolute maximum rating conditions for extended periods may affect reliability.

Power Supply Characteristics and Operating Conditions

Symbol	Parameter	Test Condition	Min.	Typ.	Max.	Units
V _{DD}	Core Supply Voltage		3.135		3.465	V
			2.375		2.625	V
V _{DDO}	Output Supply Voltage		3.135		3.465	V
			2.375		2.625	V
I _{DD}	Core Power Supply Current				70	mA
I _{DDO}	Output Power Supply Current	All LVPECL outputs unloaded			75	
		All LVDS outputs loaded			85	
		All HCSL outputs unloaded			55	
T _A	Ambient Operating Temperature		-40		85	°C

DC Electrical Specifications - Differential Inputs

Symbol	Parameter		Min.	Typ.	Max.	Units
I _{IH}	Input High current	Input = V _{DD}			150	uA
I _{IL}	Input Low current	Input = GND	-150			uA
C _{IN}	Input capacitance			3		PF
V _{IH}	Input high voltage				V _{DD} +0.3	V
V _{IL}	Input low voltage		-0.3			V
V _{PK-PK}	Input Differential Amplitude PK-PK		0.15		1.3	V
V _{CM}	Common mode input voltage		GND + 0.5		V _{DD} -0.85	V

DC Electrical Specifications - LVCMOS Inputs

Symbol	Parameter	Conditions	Min.	Typ.	Max.	Units
I _{IH}	Input High current	Input = V _{DD}			150	uA
I _{IL}	Input Low current	Input = GND	-150			uA
V _{IH}	Input high voltage	V _{DD} =3.3V	2.0		V _{DD} +0.3	V
V _{IL}	Input low voltage	V _{DD} =3.3V	-0.3		0.8	V
V _{IH}	Input high voltage	V _{DD} =2.5V	1.7		V _{DD} +0.3	V
V _{IL}	Input low voltage	V _{DD} =2.5V	-0.3		0.7	V

DC Electrical Specifications- LVPECL Outputs

Parameter	Description	Conditions	Min.	Typ.	Max.	Units
V _{OH}	Output High voltage	V _{DD} =3.3V	2.1		2.6	V
		V _{DD} =2.5V	1.3		1.6	
V _{OL}	Output Low voltage	V _{DD} =3.3V	1.3		1.8	V
		V _{DD} =2.5V	0.5		0.8	

DC Electrical Specifications- LVDS Outputs

Parameter	Description	Conditions	Min.	Typ.	Max.	Units
V _{OH}	Output High voltage			1.433		V
V _{OL}	Output Low voltage			1.064		V
V _{ocm}	Output common mode voltage			1.25		V
DV _{ocm}	Change in V _{ocm} between output states				55	mV
R _o	Output impedance		85		140	Ω

DC Electrical Specifications- HCSL Outputs

Parameter	Description	Conditions	Min.	Typ.	Max.	Units
V _{OH}	Output High voltage		520	800		mV
V _{OL}	Output Low voltage			0	150	mV

AC Electrical Specifications – Differential Outputs

Parameter	Description	Conditions	Min.	Typ.	Max.	Units
F _{OUT}	Clock output frequency	LVPECL, LVDS			1500	MHz
		HCSL			250	
T _r	Output rise time	From 20% to 80%		150		ps
T _f	Output fall time	From 80% to 20%		150		ps
T _{ODC}	Output duty cycle	Frequency<650MHz, LVPECL input	48		52	%
V _{PP}	Output swing Single-ended	LVPECL outputs	400			mV
		LVDS outputs, <650MHz	250			
		HCSL outputs	520			
T _j	Buffer additive jitter RMS	LVPECL and LVDS outputs		0.03	0.06	ps
		HCSL outputs		0.06	0.09	ps
V _{CROSS}	Absolute crossing voltage	HCSL	160		460	mV
DV _{CROSS}	Total variation of crossing voltage	HCSL			140	mV
T _{SK}	Output Skew	6 outputs devices, outputs in same bank, with same load, at DUT.		40		ps
T _{PD}	Propagation Delay			1500		ps
T _{OD}	Valid to HiZ			3	200	ns
T _{OE}	HiZ to valid			22	200	ns

Phase Noise Plot

$f_{OUT} = 156.25\text{MHz}$

Additive jitter = $\sqrt{(\text{Output jitter}^2 - \text{Input jitter}^2)} = 30\text{fs}$

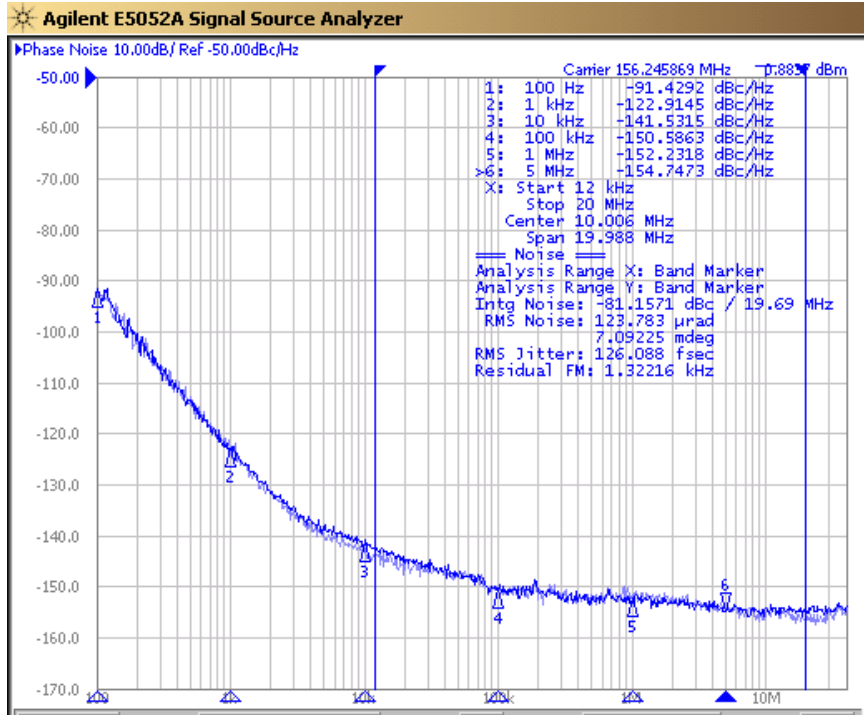

Propagation Delay

Propagation Delay T_{PD}

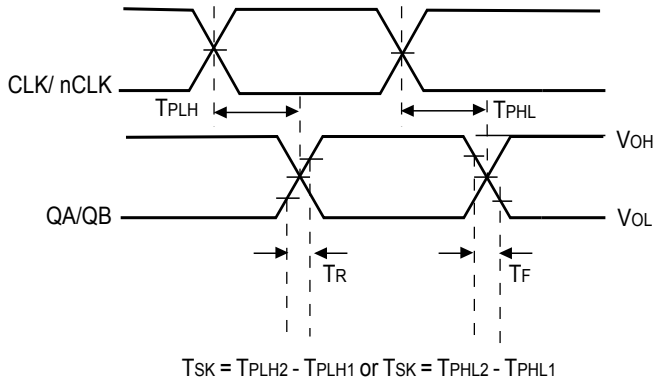

Output Skew

Output Skew T_{SK}

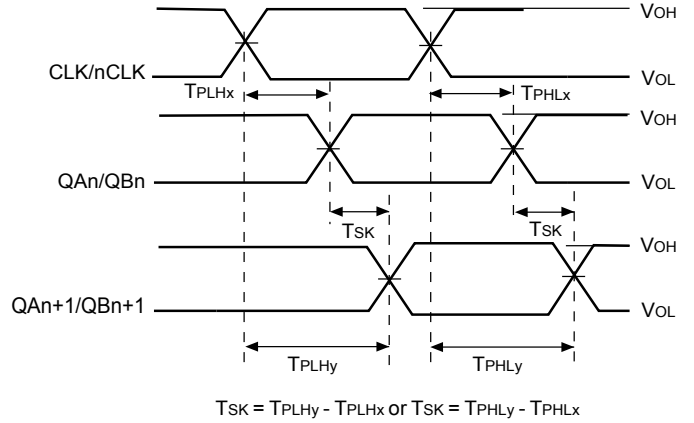

Configuration Test Load Board Termination for HCSL outputs

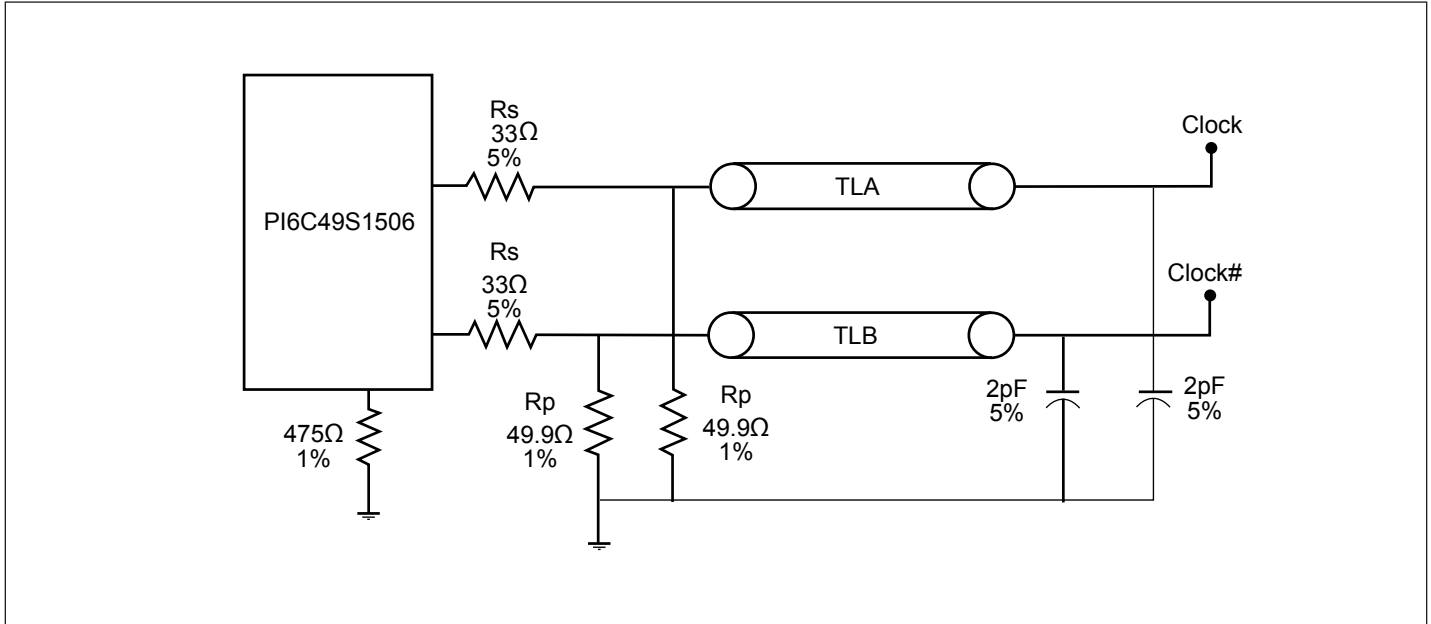

Configuration Test Load Board Termination for LVPECL/ LVDS

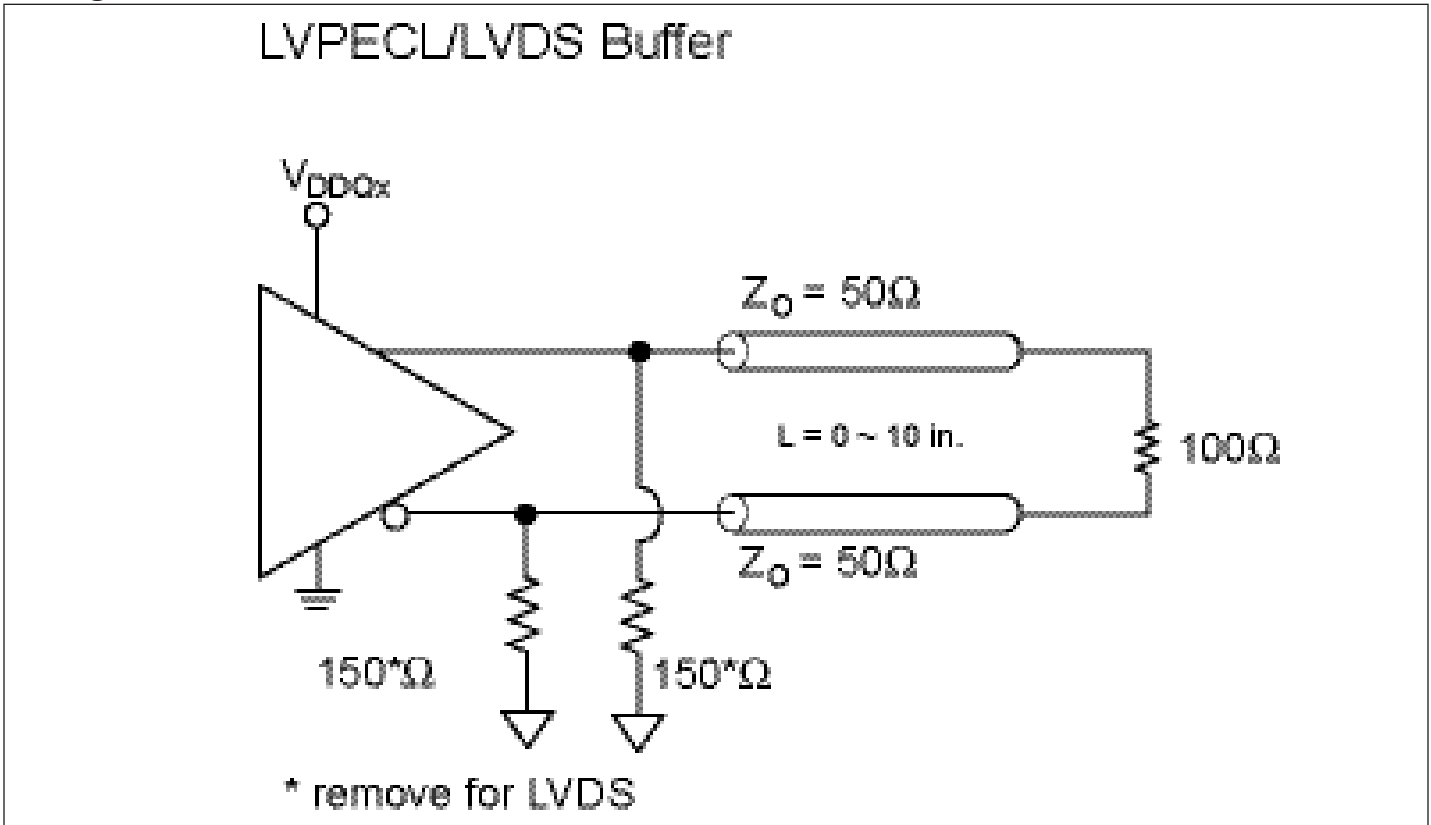

Application Information

Wiring the differential input (Use CLK0) to accept single ended levels

Figure 1 shows how the differential input can be wired to accept single ended levels. The reference voltage $V_{REF} = V_{DD}/2$ is generated by the bias resistors R1, R2 and C1. This bias circuit should be located as close as possible to the input pin. The ratio of R1 and R2 might need to be adjusted to position the V_{REF} in the center of the input voltage swing. For example, if the input clock swing is only 2.5V and $V_{DD} = 3.3V$, V_{REF} should be 1.25V and $R1/R2 = 0.609$.

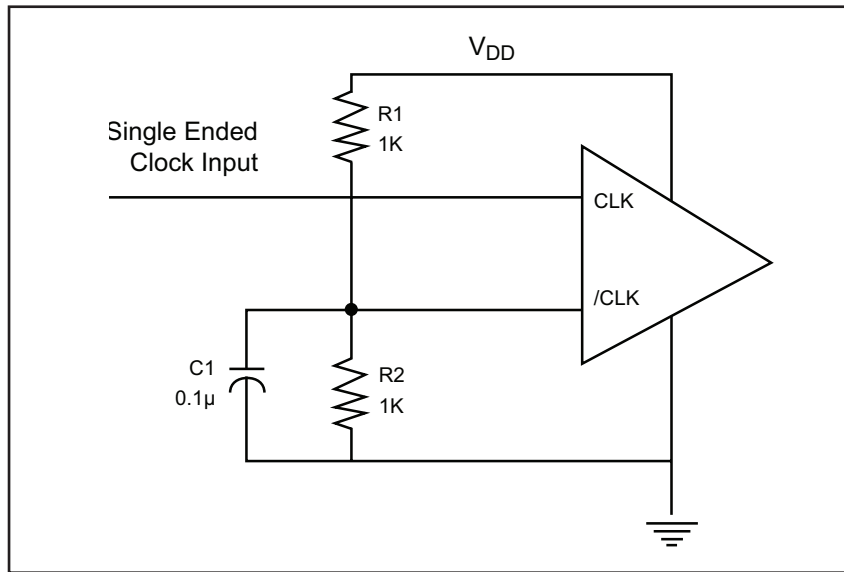
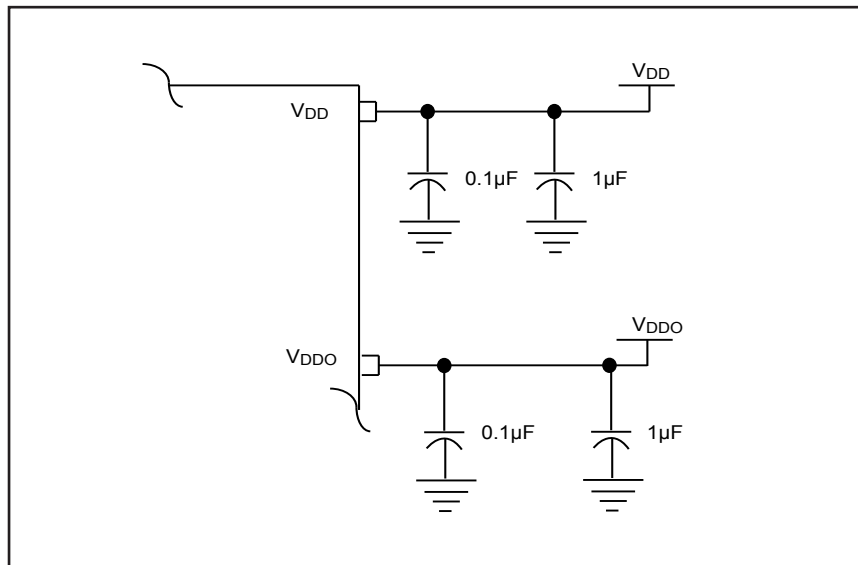
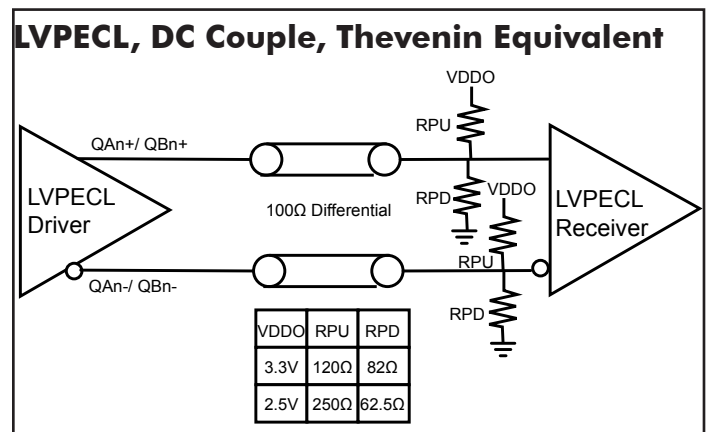
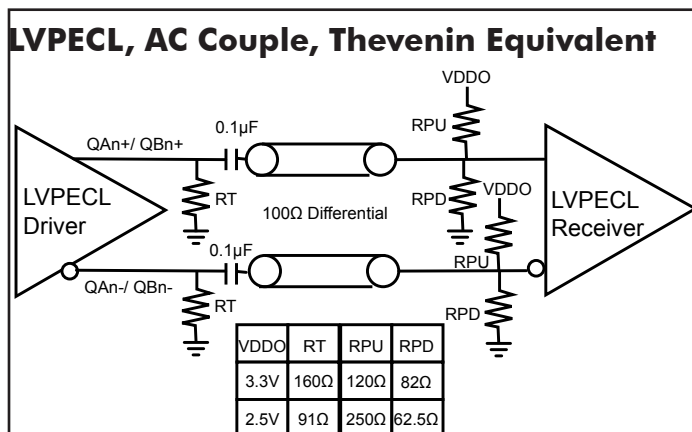
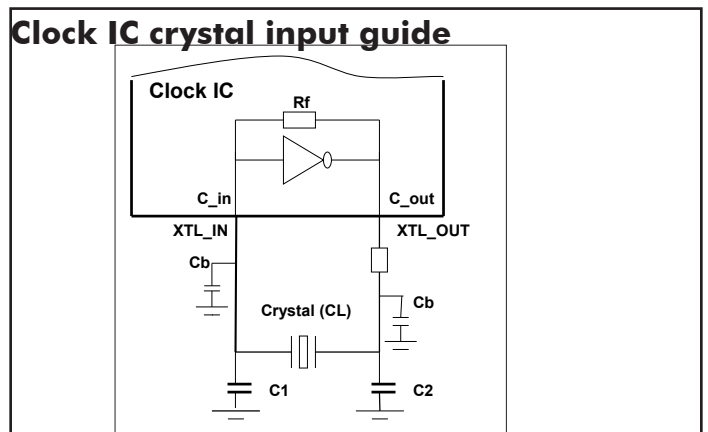
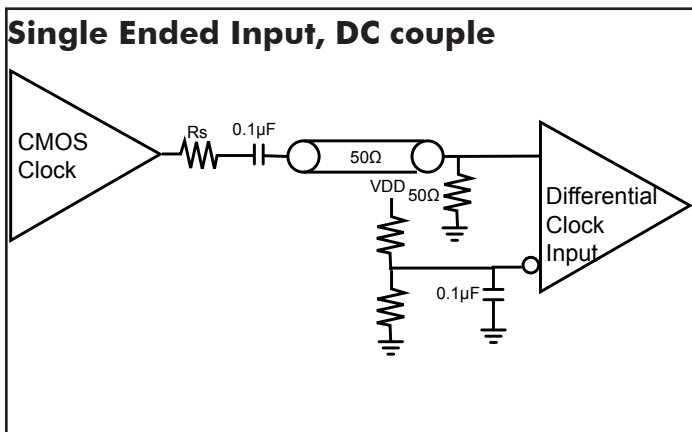
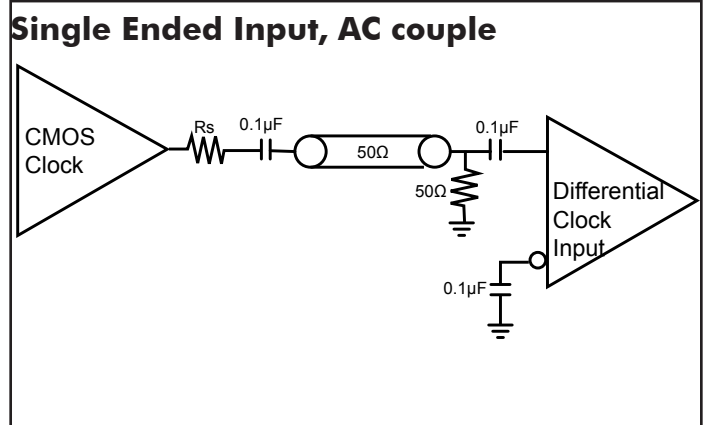
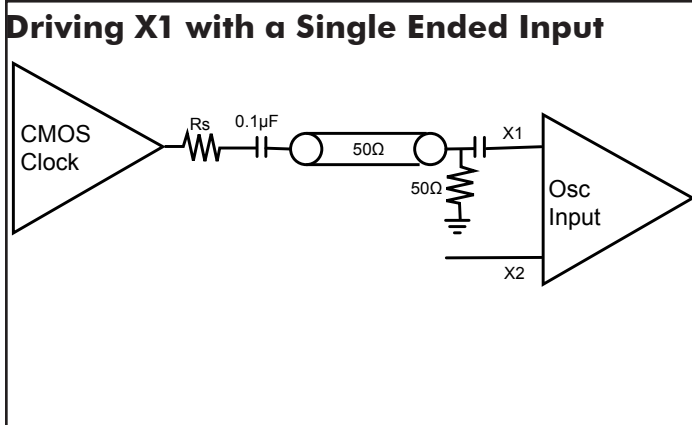

Figure 1. Single-ended input to Differential input device

Power Supply Filtering Techniques

As in any high speed analog circuitry, the power supply pins are vulnerable to random noise. To achieve optimum jitter performance, power supply isolation is required. All power pins should be individually connected to the power supply plane through vias, and 0.1µF and 1µF bypass capacitors should be used for each pin.





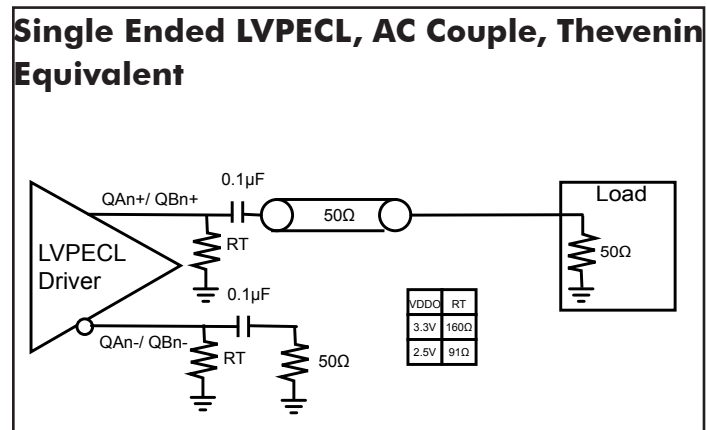
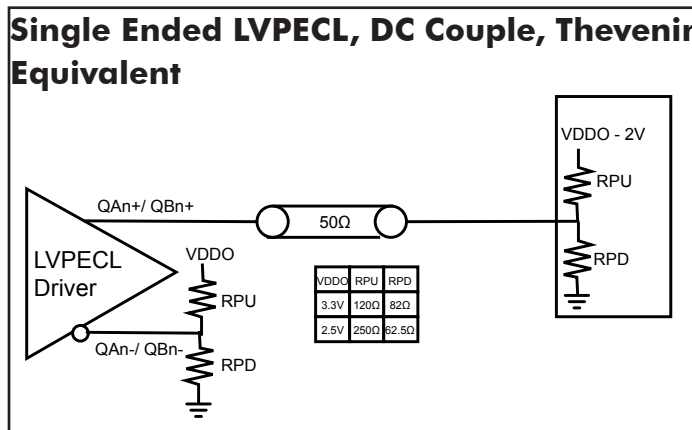
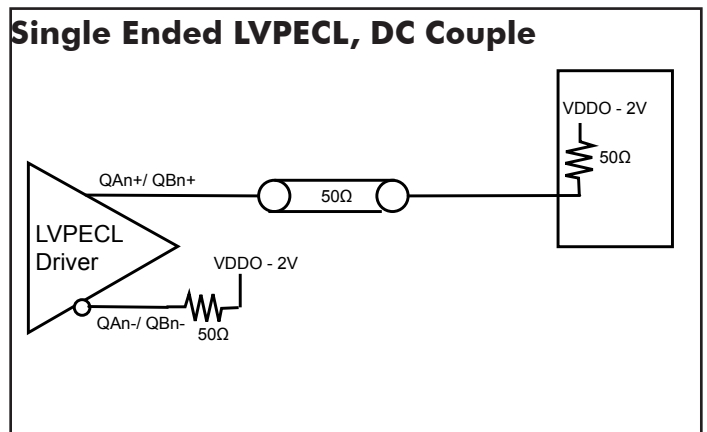
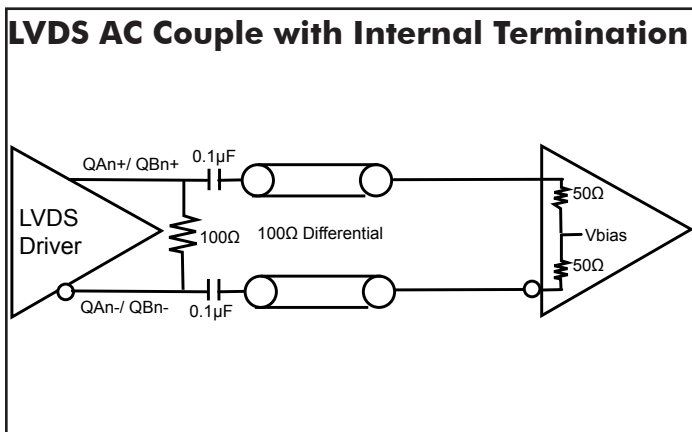
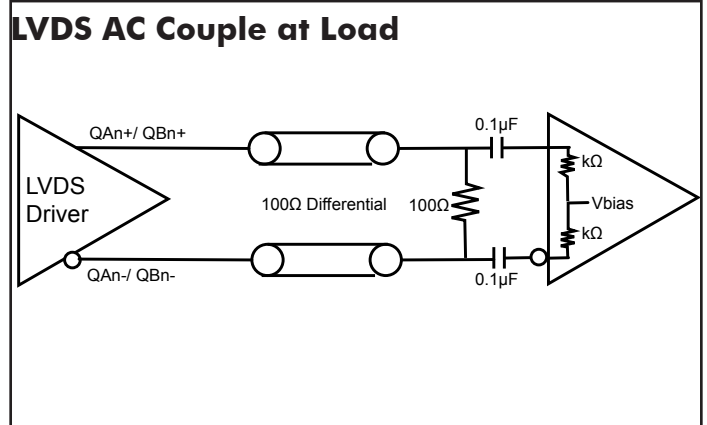
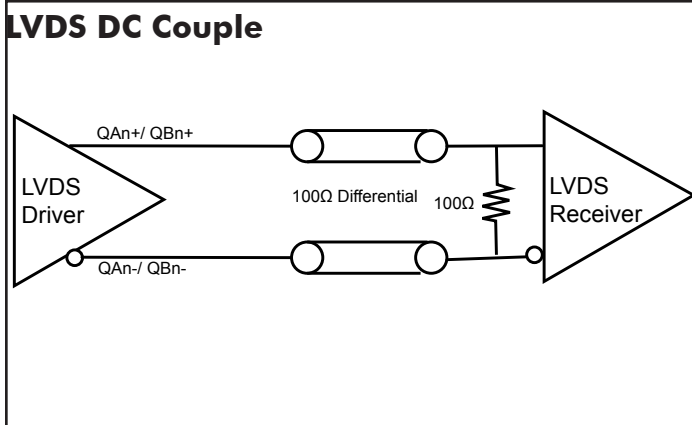

Clock IC Crystal loading cap. design guide

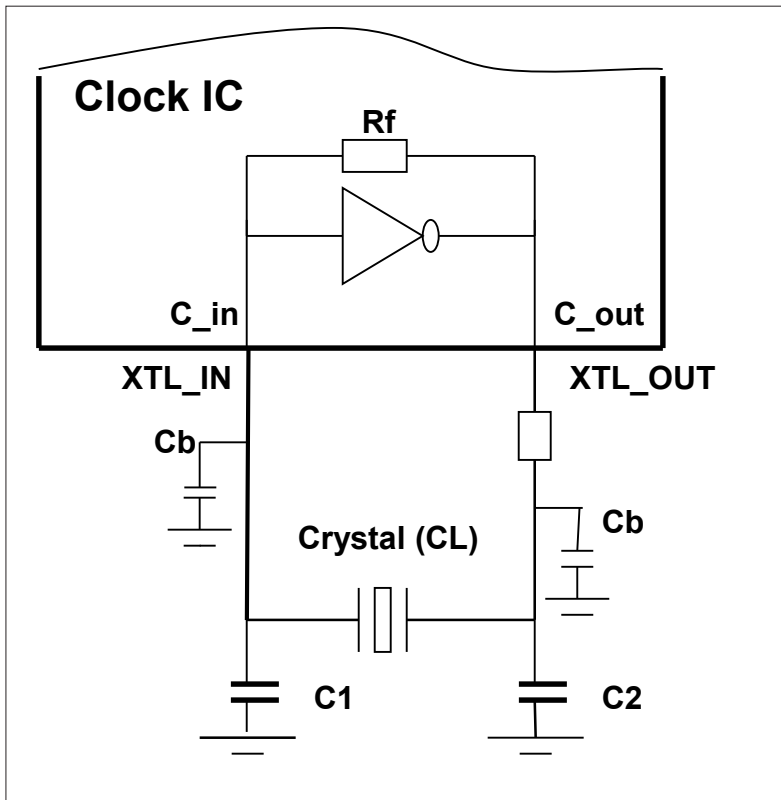

CL =crystal spec. loading cap.

C_in/out = (3~5pF) of IC pin cap.

Cb = PCB trace (2~4pF)

C1,C2 = load cap. of design

Rd = 50 to 100ohm drive level limit

Design guide: $C1=C2=2 *CL - (Cb +C_{in/out})$ to meet target +/-ppm < 20 ppm

Example1: Select CL=18 pF crystal, $C1=C2=2*(18pF) - (4pF+5pF)=27pF$, check datasheet too

Example2: For higher frequency crystal (=>20MHz), can use formula $C1=C2=2*(CL-6)$, can do fine tune of C1, C2 for more accurate ppm if necessary

Packaging Mechanical:

DOCUMENT CONTROL NO.
PD - 1814

REVISION: C
DATE: 03/09/05

Notes:

- Controlling dimensions in millimeters
- Ref.: JEDEC MS-026D/ABA
- Package Outline Exclusive of Mold Flash and Metal Burr

Pericom Semiconductor Corporation
3545 N. 1st Street, San Jose, CA 95134
1-800-435-2335 • www.pericom.com

DESCRIPTION: 32-Pin, Thin Quad Flat Package, TQFP

PACKAGE CODE: FA

Ordering Code	Package Code	Package Type	Operating Temperature
PI6C49S1506FAIE	FA	Pb-free & Green, 32-pin TQFP	-40 °C to 85 °C

Notes:

- Thermal characteristics can be found on the company web site at www.pericom.com/packaging/
- “E” denotes Pb-free and Green
- Adding an “X” at the end of the ordering code denotes tape and Reel packaging

Компания «Life Electronics» занимается поставками электронных компонентов импортного и отечественного производства от производителей и со складов крупных дистрибьюторов Европы, Америки и Азии.

С конца 2013 года компания активно расширяет линейку поставок компонентов по направлению коаксиальный кабель, кварцевые генераторы и конденсаторы (керамические, пленочные, электролитические), за счёт заключения дистрибьюторских договоров

Мы предлагаем:

- Конкуренспособные цены и скидки постоянным клиентам.
- Специальные условия для постоянных клиентов.
- Подбор аналогов.
- Поставку компонентов в любых объемах, удовлетворяющих вашим потребностям.
- Приемлемые сроки поставки, возможна ускоренная поставка.
- Доставку товара в любую точку России и стран СНГ.
- Комплексную поставку.
- Работу по проектам и поставку образцов.
- Формирование склада под заказчика.
- Сертификаты соответствия на поставляемую продукцию (по желанию клиента).
- Тестирование поставляемой продукции.
- Поставку компонентов, требующих военную и космическую приемку.
- Входной контроль качества.
- Наличие сертификата ISO.

В составе нашей компании организован Конструкторский отдел, призванный помогать разработчикам, и инженерам.

Конструкторский отдел помогает осуществить:

- Регистрацию проекта у производителя компонентов.
- Техническую поддержку проекта.
- Защиту от снятия компонента с производства.
- Оценку стоимости проекта по компонентам.
- Изготовление тестовой платы монтаж и пусконаладочные работы.



Тел: +7 (812) 336 43 04 (многоканальный)

Email: org@lifeelectronics.ru