



NXP remote keyless entry transponder combo IC NCF2960

Compact, single-chip solution for remote keyless entry

Delivering rugged performance in a very small (4 x 4 mm) footprint, this highly integrated solution maximizes design freedom and is ideal for advanced Combo-Key applications. Special features of the integrated RF transmitter support frequency hopping and ensure reliable operation even in RF-jammed environments.

Key features

- ▶ Single-chip security transponder and keyless entry solution
- ▶ 16-bit Harvard architecture
- ▶ On-chip UHF transmitter (315 / 434 / 868 / 915 MHz band)
- ▶ Transponder emulation based on HT3, HT-AES, or HT-Pro 2
- ▶ Calculation unit supporting HT3 (96-bit) and AES (128-bit)
- ▶ 16 KB user EROM for application
- ▶ 2 KB ultra-low-power EEPROM
- ▶ 1 KB RAM
- ▶ Up to eight command buttons with wake-up function
- ▶ I/O with current source for direct LED drive
- ▶ Stabilized RF output power
- ▶ Temperature sensor
- ▶ Single lithium cell operation (2.1 to 3.6 V)
- ▶ C-compiler supported software development
- ▶ HVQFN24 (4 x 4 mm) with wettable flanks

Applications

- ▶ Combo-Key applications that combine remote keyless entry with vehicle immobilization

The NXP NCF2960 is a second-generation Combo-key solution that combines a transponder, a microcontroller, and a radio transmitter in a tiny (4 x 4 mm) footprint.

The basic transponder operation is compatible with NXP's security transponder families, including HT3, HT-AES, and HT-Pro2. Custom transponder functions can be implemented using the ROM library of the device by the application.

The transponder circuitry is powered from the LF field and does not require a device battery supply. As a result, full operation is possible even when the battery is low.

The RISC controller uses NXP's third-generation Micro RISC Kernel (MRK III), a low-power implementation that features a 16-bit architecture and executes instructions in a single machine clock cycle.



The on-chip UHF transmitter requires only a single 27.6 MHz reference crystal and loop antenna matching circuitry to operate in one of the following bandwidths: 315 / 434 / 868 / 915 MHz bands. The RF multi-channel capability enables frequency hopping and ensures reliable operation in RF-jammed environments.

There are up to eight I/O ports, with one designed for use with a dedicated LED driver port, and up to eight inputs for command buttons. There is a temperature sensor for battery management and an on-chip pseudo-random number (PRN) generator for use with security protocols.

A fractional-N PLL allows compensation for initial XTL tolerance. The device includes 2 KB of ultra-low-power serial EEPROM

memory (with access control defined by the application), 1 KB of RAM, and up to 16 KB of Flash-like EROM for the application code. The keyless entry code can be generated by the built-in, hardwired calculation unit or by a software-based algorithm.

The device is housed in a tiny 24-pin HVQFN package that consumes only 16 mm² of board space, so it enables ultra-compact designs with maximum freedom for key styling. Wettable package flanks allow optical soldering inspection without an x-ray.

The Flash-like EROM of the device supports in-circuitry programming and debugging of the application code.

NCF2960 application diagram

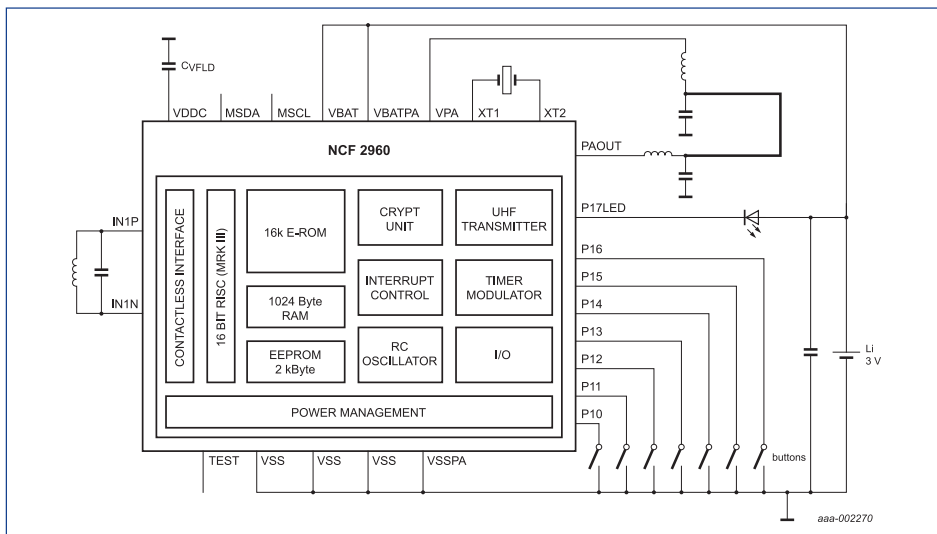

24-pin HVQFN package (4 x 4 mm)



NCF2960 demo board

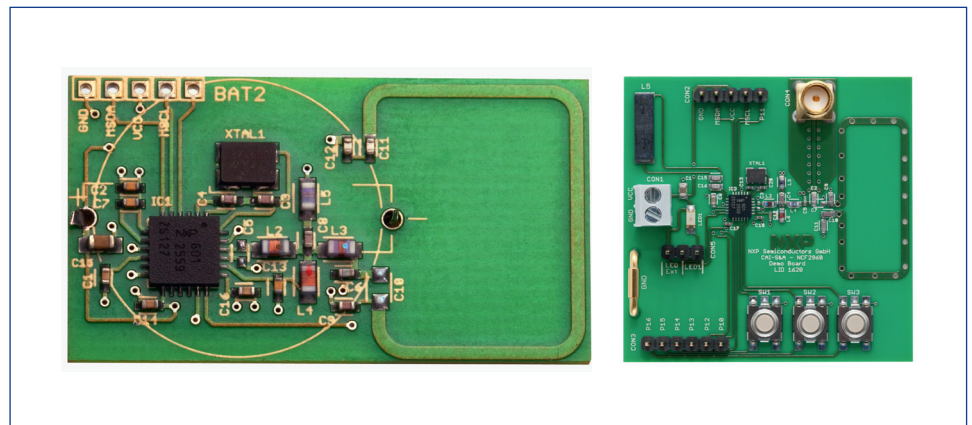

Компания «Life Electronics» занимается поставками электронных компонентов импортного и отечественного производства от производителей и со складов крупных дистрибьюторов Европы, Америки и Азии.

С конца 2013 года компания активно расширяет линейку поставок компонентов по направлению коаксиальный кабель, кварцевые генераторы и конденсаторы (керамические, пленочные, электролитические), за счёт заключения дистрибьюторских договоров

Мы предлагаем:

- Конкурентоспособные цены и скидки постоянным клиентам.
- Специальные условия для постоянных клиентов.
- Подбор аналогов.
- Поставку компонентов в любых объемах, удовлетворяющих вашим потребностям.
- Приемлемые сроки поставки, возможна ускоренная поставка.
- Доставку товара в любую точку России и стран СНГ.
- Комплексную поставку.
- Работу по проектам и поставку образцов.
- Формирование склада под заказчика.
- Сертификаты соответствия на поставляемую продукцию (по желанию клиента).
- Тестирование поставляемой продукции.
- Поставку компонентов, требующих военную и космическую приемку.
- Входной контроль качества.
- Наличие сертификата ISO.

В составе нашей компании организован Конструкторский отдел, призванный помогать разработчикам, и инженерам.

Конструкторский отдел помогает осуществить:

- Регистрацию проекта у производителя компонентов.
- Техническую поддержку проекта.
- Защиту от снятия компонента с производства.
- Оценку стоимости проекта по компонентам.
- Изготовление тестовой платы монтаж и пусконаладочные работы.



Тел: +7 (812) 336 43 04 (многоканальный)
Email: org@lifeelectronics.ru