

TET4000-48-069RA

4000 W AC-DC Front-End Power Supply

Bel Power Solutions **TET4000-48-069RA** is a 4000 Watt AC-DC power-factor-corrected (PFC) and DC-DC power supply that converts standard AC mains power or high voltage DC bus voltages into a main output of 54.5 VDC (42 – 58 VDC) for supplying 48 VDC power distribution in high performance and reliability data center equipment, servers, routers, and network switches.

The TET4000-48-069RA meets international safety standards and displays the CE-Mark for the European Low Voltage Directive (LVD).



Key Features & Benefits

- Best-in-class efficiency of up to 97%
- Wide input voltage range: Full power available at 200-250 VAC, reduced output power at 100-200 VAC
- AC input with power factor correction
- 4000 W main output with programmable voltage set-point of 42-58 VDC
- Optional Standby output 12 VDC / 60 W
- One single rear side connector for input and output power and signaling
- Parallel operation with active digital current sharing through CAN bus
- Hot-plug capable
- High density design: 44 W/in³
- Small form factor: 69 x 40.6 x 528 mm (2.72 x 1.60 x 20.79 in)
- Full digital controls for improved performance
- CAN communication interface for monitoring, control, and firmware update via bootloader, optional I²C communication instead of CAN bus foreseen
- Overtemperature, output overvoltage and overcurrent protection
- 2 Status LEDs: AC OK and DC OK with fault signaling
- Safety-approved to UL/CSA 62368-1 and IEC 62368-1
- RoHS Compliant
- US Patent Pending

Applications

- Data Center
- High Performance Servers
- Routers
- Switches



bel POWER
SOLUTIONS &
PROTECTION

a bel group

belfuse.com/power-solutions

1. ORDERING INFORMATION

TET	4000	-	48	-	069	R	A	Option Code
Product Family	Power Level	Dash	V1 Output	Dash	Width	Airflow	Input	Blank
TET Front-Ends	4000 W		48 V		69 mm	R: Reversed ¹	A: AC	Standard model

2. OVERVIEW

The TET4000-48-069RA is a fully DSP controlled, highly efficient front-end power supply. It incorporates resonant-soft-switching technology and highly integrated conversion stages to reduce component stresses, providing increased system reliability, very high efficiency and high power density. With a wide input operating voltage range and minimal linear derating of output power with respect to ambient temperature, the TET4000-48-069RA maximizes power availability in demanding server, switch, and router applications. The power supply is fan cooled and ideally suited for server integration with a matching airflow path.

The PFC stage is digitally controlled using a state-of-the-art digital signal processing algorithm to guarantee best efficiency and unity power factor over a wide operating range.

The DC-DC stage uses soft switching resonant techniques in conjunction with synchronous rectification. An active OR-ing device on the output ensures no reverse load current and renders the supply ideally suited for operation in redundant power systems.

The optional always-on +12V standby output provides power to external power distribution and management controllers. Its protection with an active OR-ing device provides for maximum reliability.

Status information is provided with front-panel LEDs. In addition, the power supply can be monitored and controlled (i.e. fan speed setpoint) via CAN communication interface. It allows full monitoring of the supply, including input and output voltage, current, power, and inside temperatures. The same CAN bus supports the bootloader to allow field update of the firmware in the DSP controllers.

Cooling is managed by a fan, controlled by the DSP controller. The fan speed is adjusted automatically depending on the actual power demand and supply temperature and can be overridden through the CAN bus. Availability of an optional I2C bus instead of CAN bus is foreseen.

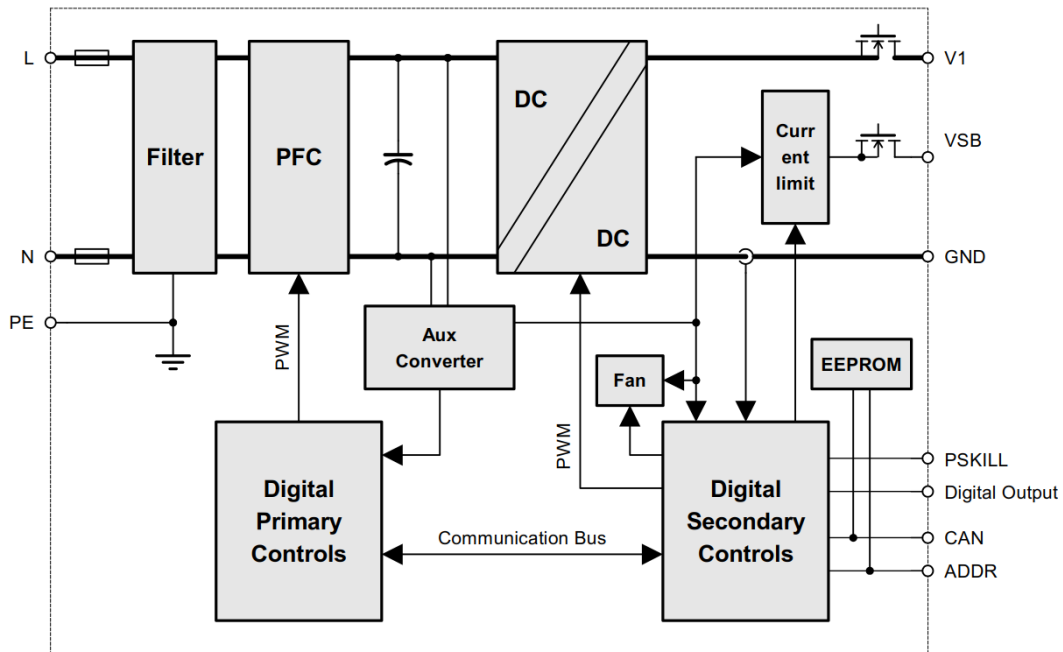

Figure 1. TET4000-48-069RA Block Diagram

¹ Front to Rear

3. ABSOLUTE MAXIMUM RATINGS

Stresses in excess of the absolute maximum ratings may cause performance degradation, adversely affect long-term reliability, and cause permanent damage to the power supply.

PARAMETER	CONDITIONS / DESCRIPTION	MIN	MAX	UNITS
$V_{i\ maxc}$	Maximum Input		300	VAC

4. INPUT

General Condition: $T_A = 0...45\ ^\circ\text{C}$ unless otherwise specified.

PARAMETER	DESCRIPTION / CONDITION	MIN	NOM	MAX	UNIT
$V_{i\ AC\ nom}$	Rated AC Input Voltage	100	230	250	VAC
$V_{i\ AC\ operating}$	AC Input Voltage Range	Operating AC Input Voltage ($V_{i\ AC\ min}$ to $V_{i\ AC\ max}$)			VAC
$V_{i\ AC\ HL}$	High line AC Input Voltage	180		275	VAC
$V_{i\ AC\ Red}$	Derated AC Input Voltage	90		180	VAC
$I_{i\ max}$	Max Input Current	$V_{i\ AC} > 200\ \text{VAC}$			23 A_{rms}
$I_{i\ p}$	Inrush Current Limitation	$V_{i\ AC\ min}$ to $V_{i\ AC\ max}$			50 A_p
F_i	Input Frequency	47	50/60	63	Hz
PF	Power Factor	$V_{i\ AC\ nom}$, 50Hz, $I_1 > 0.3\ I_{1\ nom}$			0.97 W/VA
THD	Total Harmonic Distortion on Input Current	$V_{i\ AC\ HL}$, $> 50\ \% P_{1\ nom}$			3 5 %
$V_{i\ AC\ on}$	Turn-on AC Input Voltage ²	Ramping up			86 88 90 VAC
$V_{i\ AC\ off}$	Turn-off AC Input Voltage	Ramping down			80 83 86 VAC
η	Efficiency ³	$V_i = 277\ \text{VAC}$, $0.1 \cdot I_{1\ nom}$, $I_{SB} = 0A$, $V_x\ nom$, $T_A = 25^\circ\text{C}$			93.0
		$V_i = 277\ \text{VAC}$, $0.2 \cdot I_{1\ nom}$, $I_{SB} = 0A$, $V_x\ nom$, $T_A = 25^\circ\text{C}$			95.7
		$V_i = 277\ \text{VAC}$, $0.5 \cdot I_{1\ nom}$, $I_{SB} = 0A$, $V_x\ nom$, $T_A = 25^\circ\text{C}$			96.5
		$V_i = 277\ \text{VAC}$, $I_{1\ nom}$, $I_{SB} = 0A$, $V_x\ nom$, $T_A = 25^\circ\text{C}$			95.5
T_{hold}	Hold-up Time	After last AC zero crossing, $V_i > 41\ \text{V}$, $V_{i\ AC\ nom}$, $P_{1\ nom}$			15 ms
$T_{hold-up, vsb-to-vo1}$	Time from Vo1 to Vsb Leaving Regulation	All hold-up conditions			40 ms

4.1. INPUT FUSE

Fast-acting 30 A input fuses (6.3 × 32 mm) in series with both the L- and N-line inside the power supply protect against severe defects. The fuses are not accessible from the outside and are therefore not serviceable parts.

4.2. INRUSH CURRENT

The AC-DC power supply exhibits an X capacitance of 5.8 μF , resulting in a low and short peak current, when the supply is connected to the mains. The internal bulk capacitors will be charged through NTC resistors which will limit the inrush current.

NOTE:

Do not repeat plug-in / out operations below 30 sec interval time, or else the internal in-rush current limiting device (NTC) may not sufficiently cool down and excessive inrush current may result.

² The Front-End is provided with a minimum hysteresis of 3 V during turn-on and turn-off within the ranges

³ Efficiency measured with fan loss included in PSU losses

4.3. INPUT UNDER-VOLTAGE

If the input voltage is reduced below the input under-voltage lockout threshold $V_{iAC\ off}$, the supply will be inhibited. Once the input voltage rises above $V_{iAC\ on}$, the supply will return to normal operation again.

4.4. POWER FACTOR CORRECTION

Power factor correction (PFC) is achieved by controlling the input current waveform synchronously with the input voltage. A fully digital controller is implemented giving outstanding PFC results over a wide input voltage and load range. The input current will follow the shape of the input voltage. If, for instance, the input voltage has a trapezoidal waveform, then the current will also show a trapezoidal waveform.

4.5. EFFICIENCY

The high efficiency is achieved by using state-of-the-art silicon power devices in conjunction with soft-transition topologies minimizing switching losses and a full digital control scheme. Synchronous rectifiers on the output reduce the losses in the high current output path. The rpm of the fan is digitally controlled to keep all components at an optimal operating temperature regardless of the ambient temperature and load conditions. *Figure 2* shows the measured efficiency with AC input voltage applied, with standby output at zero load.

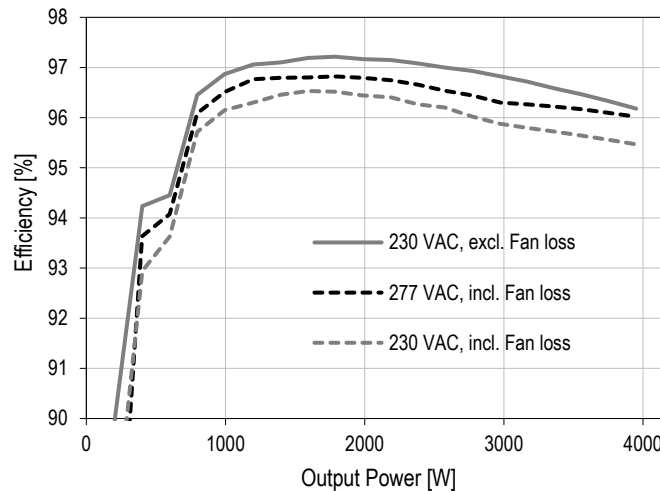

Figure 2. Typical Efficiency vs. Load Current

5. OUTPUT

General Condition: $T_A = 0 \dots 45^\circ\text{C}$ unless otherwise noted.

PARAMETER	DESCRIPTION / CONDITION	MIN	NOM	MAX	UNIT	
Main Output V₁						
V _{1 nom}	Nominal Output Voltage	0.5 · I _{1 nom} , T _a ≤ 45°C		54.5	VDC	
V _{1 prg}	Programmable Output Voltage Range	0.5 · I _{1 nom} , T _a ≤ 45°C		42	58	VDC
V _{1 set}	Output Setpoint Accuracy	0.5 · I _{1 nom} , T _a ≤ 45°C		-0.5	+0.5	% V _{1 nom}
dV _{1 tot}	Total Regulation	V _{i min} to V _{i max} , 0 to 100% I _{1 nom} , T _{a min} to T _{a max}		-2	+2	% V _{1 nom}
P _{1 nom}	Nominal Output Power	V _{i AC HL} , T _a ≤ 45°C, V ₁ ≥ 48.0 V		4000		W
		V _{i AC HL} , T _a = 55°C, V ₁ ≥ 48.0 V		3000		W
I _{1 nom}	Nominal Output Current	V _{i AC HL} , T _a ≤ 45°C, V ₁ = 54.5 V		73		ADC
		V _{i AC HL} , T _a = 55°C, V ₁ = 54.5 V		55		ADC
		V _{i AC HL} , T _a ≤ 45°C, V ₁ = 48.0 V		83		ADC
		V _{i AC HL} , T _a ≤ 45°C, V ₁ = 58.0 V		69		ADC
P _{1 red}	Available Output Power at V _{in} < 180 V	V _{i AC Red} , T _a ≤ 45°C, V ₁ ≥ 48.0 V		22Arms*Vin - 400W ⁴		W
P _{1 red}	Low Line Output Power	V _i = 120 VAC, T _a ≤ 45°C, V ₁ ≥ 48.0 V		2240		W
I _{1 ol}	Short Time Over Load Current, Maximum duration 10 ms	V _{i AC Red} , V _{i AC HL} , relative to static output current available			110	%
V _{1 pp}	Output Ripple Voltage	20 MHz BW			1000	mVpp
dV _{1 Load}	Load Regulation	V _i = V _{1 nom} , 0 - 100 % I _{1 nom}		-10		mV/A
dV _{1 Line}	Line Regulation	V _i = V _{i AC min} ... V _{i AC max}		0		mV
dI _{share}	Current Sharing	Deviation from I _{1 tot} / N, I ₁ > 25% I _{1 nom}		-2.5	+2.5	ADC
dV _{dyn}	Dynamic Load Regulation	ΔI ₁ = 50% I _{1 nom} , I ₁ = 10 ... 100% I _{1 nom} , dI ₁ /dt = 1A/μs, f = 2 ... 50 Hz, Duty cycle = 20 ... 80%		-2	2	V
T _{rec}	Recovery Time	Within 1% of V ₁ final steady state I ₁ = 10 ... 100% I _{1 nom}			2	ms
t _{AC V1}	Start-up Time from AC	Time from V _i in range to V ₁ in regulation, T _A > 10 °C			4 ⁵	sec
t _{V1 rise}	Rise Time	V ₁ = 10 ... 90% V _{1 nom}		12		ms
C _{V1}	Maximum Capacitive Load				15000	μF

⁴ Example: At nominal grid 120 VAC the max. output power is 2240 W, will be provided also with grid fluctuation -10 % down to 108 VAC.

⁵ At low ambient temperature T_A < 10 °C this time can rise to max 10 s

5.1. STANDBY OUTPUT

An optional standby output is available, delivering 12 V with up to 5 A, to provide power to system management controls.

The output is always enabled if the input voltage is within operating range, and provides over current, over voltage and over temperature protections. Current share on standby output is provided by passive droop sharing.

General Condition: $T_A = 0 \dots 45 \text{ }^\circ\text{C}$ unless otherwise noted.

PARAMETER	DESCRIPTION / CONDITION	MIN	NOM	MAX	UNIT
<i>Standby output V_{SB}</i>					
V _{SB nom}	Nominal Output Voltage	I _{SB} = 0 A, T _A = 25 °C	12		VDC
V _{SB set}	Output Setpoint Accuracy	I _{SB} = 0 A, T _A = 25 °C	-2	+2	% V _{SB nom}
dV _{SB tot}	Total Regulation	V _{i min} to V _{i max} , 0 to 100 % I _{SB nom} , T _{A min} to T _{A max}	-5	+3	% V _{SB nom}
P _{SB nom}	Nominal Output Power		60		W
I _{SB nom}	Nominal Output Current		5		ADC
V _{SB pp}	Output Ripple Voltage	20 MHz BW		300	mVpp
dV _{SB Load}	Load Regulation	0 - 100 % I _{SB nom}	-72		mV/A
dV _{SB Line}	Line Regulation	V _i = V _{i AC min} ... V _{i AC max}	0		mV
dI _{share}	Current Sharing	Deviation from I _{SB tot} / N		2	ADC
dV _{dyn}	Dynamic Load Regulation	$\Delta I_{SB} = 50\% I_{SB nom}$, I _{SB} = 10 ... 100% I _{SB nom} , dI _{SB} /dt = 0.1A/μs, f = 2 ... 50 Hz, Duty cycle = 20 ... 80%	-600	600	mV
T _{rec}	Recovery Time	Within 1% of V _{SB} final steady state		2	ms
t _{AC VSB}	Start-up Time from AC	Time from V _i in range to V _{SB} in regulation, T _A > 10°C		3 ⁶	sec
t _{VSB rise}	Rise Time	V _{SB} = 10 ... 90% V _{SB nom}	15		ms
C _{VSB}	Maximum Capacitive Load			3000	μF

5.2. OUTPUT VOLTAGE RIPPLE

The internal output capacitance at the power supply output (behind OR-ing element) is minimized to prevent disturbances during hot plug. To provide low ripple voltage at the application, external capacitors should be added at the input of the connected load circuits.

5.3. OVERSUBSCRIPTION

The main output has the capability to allow a load current of up to 10 A above the nominal output current rating for a maximum duration of 5 ms. This allows the system to consume extended power for short time dynamic processes. Oversubscription can be used with maximum 10% duty cycle. If the output current is less than 10 A above nominal output current, then the oversubscription time can be longer.

5.4. OUTPUT ISOLATION

Main and standby output (if available) and all signals are isolated from the chassis and protective earth connection, although the applied voltage must not exceed 100 V_{peak} to prevent any damage to the power supply.

The main output return path serves as main and standby power return and reference for the two address signals ADDR0 and ADDR1. Care needs to be taken to reference these address signals as close as possible to the PSU's GND pins.

The CAN bus lines CAN_H and CAN_L, the output signal ACOK_L and the input signal PSKILL are referenced to signal ground SGND. These signals and SGND are isolated from main output and chassis allowing a maximum voltage of 50 V_{peak} between signals/SGND and main return GND. Signal ground SGND may be connected to power ground GND within the application, shown as dotted lines in *Figure 3*, allowing powering of system communication and logic from VSB output.

⁶ At low ambient temperature T_A < 10 °C this time can rise to max 10s

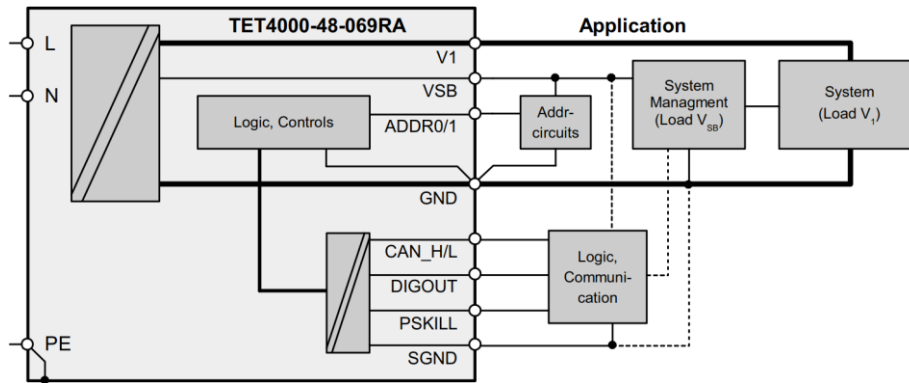

Figure 3. Output connection

6. PROTECTION

PARAMETER	DESCRIPTION / CONDITION	MIN	NOM	MAX	UNIT
F	Input Fuses (L+N)	Not user accessible, fast-acting (F)			A
$V_{1\text{ ov}}$	OV Threshold V_1	64	66	68	VDC
$t_{V1\text{ ov}}$	OV Latch Off Time V_1	1			ms
$P_{1\text{ lim}}$	Nominal Power Limitation	$V_{1\text{ AC HL}}, T_a \leq 45^\circ\text{C}, V_1 \geq 48\text{ V}$	4000	4100	W
		$V_{1\text{ AC HL}}, T_a = 55^\circ\text{C}, V_1 \geq 48\text{ V}$	3000	3100	W
$I_{1\text{ lim}}$	Nominal Current Limitation	$V_{1\text{ AC HL}}, T_a \leq 45^\circ\text{C}, V_1 = 54.5\text{ V}$	73	76	ADC
		$V_{1\text{ AC HL}}, T_a \leq 45^\circ\text{C}, V_1 = 42 \dots 48\text{ V}$	83	86	ADC
		$V_{1\text{ AC HL}}, T_a = 55^\circ\text{C}, V_1 = 54.5\text{ V}$	55	57	ADC
$t_{1\text{ lim}}$	Power Limit Blanking Time	Time until power limit is reduced to nominal value			ms
$P_{1\text{ ol lim}}$	Power Limit during Short Time Over Load V_1	$V_{1\text{ AC HL}}, T_a \leq 45^\circ\text{C}, V_1 \geq 48\text{ V}$, Maximum duration 10 ms			W
$I_{1\text{ ol lim}}$	Current Limit during Short Time Over Load V_1	$V_{1\text{ AC HL}}, T_a \leq 45^\circ\text{C}, V_1 = 54.5\text{ V}$, Maximum duration 5 ms			A
$I_{1\text{ sc}}$	Max Short Circuit Current V_1	$V_1 < 10\text{ VDC}$, excluding output capacitor discharging current			83 ADC
$t_{1\text{ sc off}}$	Short Circuit Latch off time	Time to latch off when in short circuit or output under voltage ($V_1 < V_{1\text{ uv}}$)			100 ms
$V_{1\text{ uv}}$	Output Under Voltage Protection	39	40	41	VDC
$t_{1\text{ uv}}$	Output Under Voltage Protection Delay time	$V_1 < V_{1\text{ uv}}$			250 ms
T_{SD}	Over Temperature on critical points	Inlet Ambient Temperature	60		°C
		PFC Primary Heatsink Temperature	90		
		DC/DC Primary Heatsink Temperature	90		
		Secondary Sync Mosfet Temperature	100		
$V_{\text{SB UV}}$	Output Under Voltage Protection Standby	11.1	11.2	11.3	VDC
$I_{\text{SB Lim}}$	Standby Over Current Limit	5.0	5.5	ADC	

6.1. LATCH OFF

For all fault conditions except over current on standby output and over temperature, the output will shut down and latch off. The latch can be cleared by recycling the input voltage or the PSKILL input. A failure on the main output will only shut down the main output, while the optional standby output continues to operate. A failure on the standby output will only shut down the standby output.

Overtemperature protection has a hysteretic behavior. Once the power supply has cooled down below the warning thresholds the PSU will restart.

6.2. OVER VOLTAGE PROTECTION

The TET front-ends provide a variable threshold, tracking programmed output voltage set-point, implemented in FW plus a fixed threshold over voltage (OV) protection implemented with a HW comparator. Once an OV condition has been triggered, the supply will shut down and latch off as described under 6.1.

6.3. UNDER VOLTAGE DETECTION

Both main and optional standby outputs are monitored. LED and PWOK_L pin signal if the output voltage exceeds $\pm 7\%$ of its nominal voltage.

Output under voltage protection is provided on both outputs. When the main output falls below V_{1UV} or the standby output falls below V_{SBUV} , the output is inhibited and latches off as described under 6.1.

6.4. CURRENT LIMITATION MAIN OUTPUT

Two different over current protection features are implemented on the main output.

If the output current exceeds I_{1lim} for more than 10 ms the output will reduce its voltage, to reduce output current to I_{1lim} . In case the output voltage will be reduced below the under-voltage level V_{1UV} the output will turn off after 250 ms, signaling an under-voltage fault.

The 2nd protection is a substantially rectangular output characteristic controlled by a software feedback loop. This protects the power supply and system during the 10 ms blanking time of the short time over load mode. If the output current is rising fast and reaches I_{1ollim} , the supply will immediately reduce its output voltage to prevent the output current from exceeding I_{1ollim} . When the output current is reduced below I_{1ollim} , the output voltage will return to its nominal value.

The main output current limitation level I_{1lim} and I_{1ollim} are decreased if the ambient (inlet) temperature increases beyond 45°C. The current limit depends on programmed output voltage, to keep output power constant at about 4000 W. See also *Figure 4* for output characteristic and current limitation at different output voltage settings.

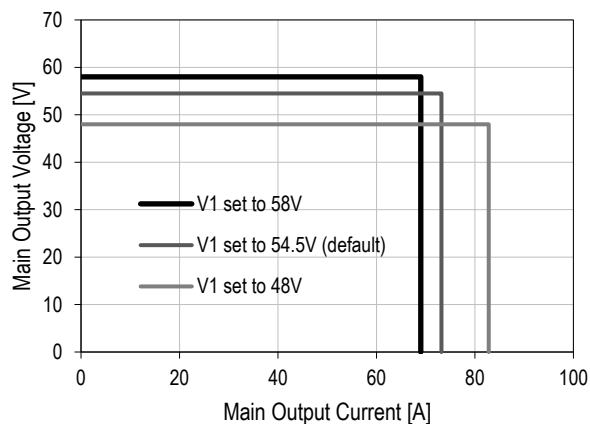

Figure 4. Output characteristics V_1

6.5. CURRENT LIMITATION STANDBY OUTPUT

The standby output has a hiccup current limitation implemented. If the standby current exceeds I_{SBLim} the standby converter switches off and retries automatically after 1 second off time.

7. MONITORING

The power supply provides information about operating conditions through its CAN bus interface. Details can be found in the CAN Communication Manual BCA.00231.0. Accuracy of sensors within PSU is given in following table.

PARAMETER	DESCRIPTION / CONDITION	MIN	NOM	MAX	UNIT
$V_{i\ mon}$	Input RMS Voltage $V_{i\ min} \leq V_i \leq V_{i\ max}$	-3		+3	V_{rms}
$I_{i\ mon}$	Input RMS Current	-1.25		+1.25	A_{rms}
$P_{i\ mon}$	True Input Power	-200		+200	W
$V_{1\ mon}$	V_1 Voltage $V_1 > 40\ VDC$	-1		+1	%
$I_{1\ mon}$	V_1 Current $I_1 > 25\ A$ $I_1 \leq 25\ A$	-2 -0.5		+2 +0.5	% A
$V_{SB\ mon}$	V_{SB} Voltage $I_{SB} = 0 \dots 5A$	-0.25		+0.25	V
$I_{SB\ mon}$	V_{SB} Current $I_{SB} = 0 \dots 5A$	-0.25		+0.25	A
$P_{1\ mon}$	P_1 Output Power $P_1 > 1000\ W$ $P_1 \leq 1000\ W$	-3 -30		+3 +30	% W
$P_{SB\ mon}$	P_{SB} Output Power $P_{SB} = 0 \dots 60W$	-4		+4	W
$T_{a\ mon}$	Inlet air temperature $T_a = 0 \dots 45^\circ C$	-5		+5	$^\circ C$

8. SIGNALING AND CONTROL

8.1. ELECTRICAL CHARACTERISTICS

PARAMETER	DESCRIPTION / CONDITION	MIN	NOM	MAX	UNIT
PSKILL					
V_{iL}	Input low level voltage (Main output enabled)	-0.2		0.8	V
V_{iH}	Input high level voltage (Main output disabled)	2.0		3.5	V
$I_{iL, H}$	Maximum input sink or source current	0		1	mA
$R_{puPSKILL}$	Internal pull up resistor on PSKILL to internal 3.3V		4.75		k Ω
ACOK_L					
V_{oL}	Output low level voltage $I_{sink} < 4\ mA$	-0.2		0.4	V
V_{puACOK_L}	External pull up voltage	0		13	V
R_{puACOK_L}	Recommended external pull up resistor on ACOK_L at $V_{puACOK_L} = 3.3\ V$		10		k Ω
Low level output	Input voltage within operating range				
High level output	No input voltage, or low input voltage				

8.2. PSKILL INPUT

The PSKILL input is an active-high and trailing pin in the connector and is used to switch off the main output as soon as the power supply is being plugged out.

This input can be connected to SGND, enabling main output as soon as power supply is plugged-in into system with input voltage present. Alternatively, this input can be driven by a logical signal (preferably an open collector signal) from the application, allowing remote control of the main output.

The standby output will remain on regardless of the PSKILL input state.

This pin is isolated and referred to SGND. A 4.75 kOhm pullup resistor to 3.3 V is present within the power supply.

8.3. ACOK_L OUTPUT

The ACOK_L is an isolated open collector output referred to SGND. It requires an external pull-up resistor. A low voltage on this pin reflects input voltage to be within operating range.

8.4. CAN BUS INTERFACE

The CAN bus interface serves for information exchange between paralleled power supplies (e.g. for current share) and for communication with a system controller (e.g. voltage setting, monitoring). The CAN bus operates at 1000 kbit/s with a Bel defined protocol. System wiring requires only interconnection of CAN_H and CAN_L lines, in addition a 120 Ohm termination resistor is required at each end of the CAN bus to prevent signal reflections.

NOTE: To enable active current share between paralleled power supplies, their CAN bus interface must be interconnected.

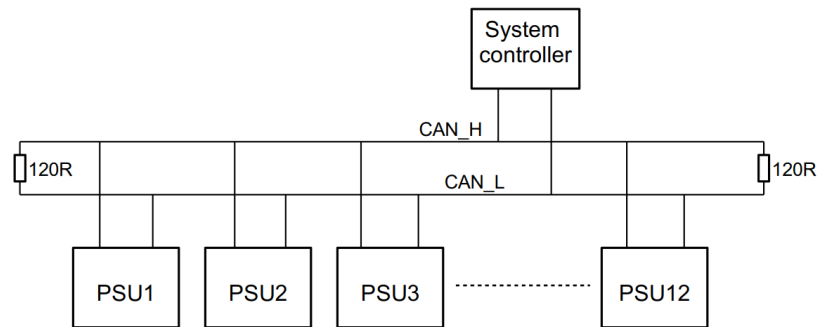

Figure 5. CAN bus wiring

8.5. CAN ADDRESSING

The CAN address (Node-ID) of each PSU is a combination of Shelf Number and PSU position within the shelf.

The Shelf-Number is given by a precision voltage source to be applied to the ADDR1 pin (versus power GND). The output impedance of this voltage source should not exceed 100 Ohm and the voltage range is between 0.0 V and 3.0 V. Accuracy is required to be ± 30 mV or better.

A resistor needs to be connected from the ADDR0 pin to power GND to define the position of the PSU slot within the shelf. The resistor tolerance needs to be $\pm 1\%$ or lower.

The resulting Node-ID is given by following formula: $\text{Node-ID} = (\text{Shelf-Nr} - 1) * 16 + \text{Slot-Nr}$.

If the PSU is not running, the ADDR0 pin is pulled low and the ADDR1 pin is switched to a high impedance input. Thus, the ADDR1 signal may be shared between PSUs while ADDR0 needs to be separated. Refer to the CAN manual for further information.

If either ADDR0 or ADDR1 pins are left open or shorted to GND or 3.0 V the PSU will detect an invalid Node-Id (reflected by corresponding LED state) and will not respond to a CAN request.

Shelf-Nr	Voltage on ADDR1 [V]	Slot-Nr	Resistor on ADDR0 [Ohm]	Resulting Voltage on ADDR0 [V]
1	0.332	1	150	0.130
2	0.664	2	470	0.374
3	0.998	3	866	0.624
4	1.330	4	1330	0.862
5	1.666	5	1960	1.118
6	1.998	6	2740	1.361
7	2.332	7	3900	1.625
8	2.664	8	5620	1.890
		9	8060	2.129
		10	12700	2.381
		11	22600	2.618
		12	75000	2.874

Table 1. Address pin voltage and resistor requirements

8.6. FRONT LEDs

The front-end has 2 front LEDs showing the status of the supply. LED number one is green and indicates AC power is on or off, while LED number two is bi-colored: green and yellow, and indicates DC power presence or fault situations. If the PSU is bootloaded both LEDs are alternating green blinking. All other conditions are specified in the *Table 2*. The order of the criteria in the table corresponds to the testing precedence in the controller. LEDs are only available if sufficient input voltage is applied for operation of the internal supply circuits.

OPERATING CONDITION	LED SIGNALING
Bootloading	LEDs alternately blinking
AC LED	
AC Line within range	Solid Green
AC Line out of range	Off
DC LED	
V_I or V_{SB} out of regulation	
Over temperature shutdown	
Output over voltage shutdown (V_I or V_{SB})	Solid Yellow
Output under voltage shutdown (V_I or V_{SB})	
Output over current shutdown (V_I or V_{SB})	
Invalid Node-Id	Blinking Yellow
Main output disabled by application	Blinking Green
Normal Operation	Solid Green
PSU backsupplied and input voltage present but out of range	Blinking Yellow
Otherwise	All LEDs off

Table 2. LED Status

8.7. CURRENT SHARE

The front-end has an active current share scheme implemented for V1. CAN bus interface of the paralleled power supplies need to be interconnected to activate the sharing function.

The controller implements a Master/Slave current share function. The power supply providing the largest current among the group is automatically the Master. The other supplies will operate as Slaves and increase their output current to a value close to the Master by slightly increasing their output voltage. The voltage increase is limited to +1 V.

The standby output uses a passive current share method (droop output voltage characteristic).

Due to non-ideal current share the maximum total output power of paralleled power supplies is less than the theoretical maximum and is defined in *Table 3*.

No of paralleled PSUs	Maximum available power on main output V		Maximum available power on standby output (optional)	
	without redundancy	n+1 redundancy	without redundancy	n+1 redundancy
1	4000 W	-	60 W	-
2	7800 W	4000 W	95 W	60 W
3	11600 W	7800 W	131 W	95 W
4	15400 W	11600 W	166 W	131 W
5	19200 W	15400 W	202 W	166 W
6	23000 W	19200 W	238 W	202 W

Table 3. Power available when PSU in redundant operation

9. TEMPERATURE AND FAN CONTROL

To achieve best cooling results sufficient airflow through the supply must be ensured. Do not block or obstruct the airflow at the rear of the supply by placing large objects directly at the output connector. The TET4000-48-069RA is provided with a reverse airflow, which means the air enters through the front of the supply and leaves at the rear.

9.1. FAN CONTROL

The average speed of the two individual fans within the dual-axis-fan is controlled to meet the reference. The reference is given by the maximum of following 3 items:

- Load depending Fan Speed curve, see *Figure 6*. This curve is in use at nominal conditions.
- Component depending Fan Speed curve according to *Figure 7*.
- System commanded Fan Speed through CAN bus.

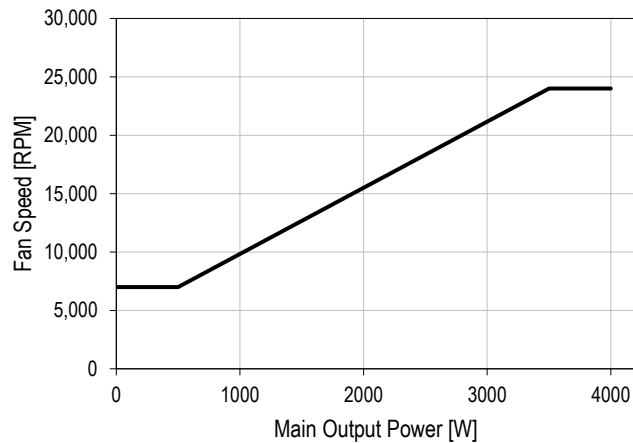

Figure 6. Fan speed versus main output power

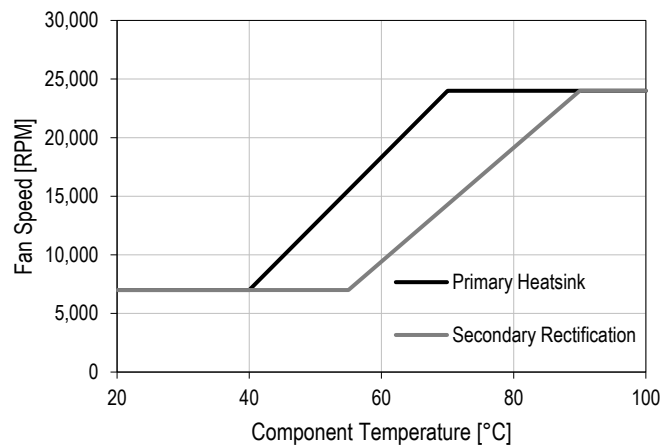

Figure 7. Fan speed versus power stage temperatures

10. ELECTROMAGNETIC COMPATIBILITY

10.1. IMMUNITY

NOTE: Most of the immunity requirements are derived from EN 55024:1998/A2:2003.

PARAMETER	DESCRIPTION / CONDITION	CRITERION
ESD Contact Discharge	IEC / EN 61000-4-2, ±8 kV, 25+25 discharges per test point (metallic case, LEDs, connector body)	A
ESD Air Discharge	IEC / EN 61000-4-2, ±15 kV, 25+25 discharges per test point (non-metallic user accessible surfaces)	A
Radiated Electromagnetic Field	IEC / EN 61000-4-3, 10 V/m, 1 kHz/80% Amplitude Modulation, 1 µs Pulse Modulation, 10 kHz...2 GHz	A
Burst	IEC / EN 61000-4-4, level 3 AC port ±2 kV, 1 minute	A
Surge	IEC / EN 61000-4-5, level 3 Line to earth: ±2 kV Line to line: ±2 kV @	A
RF Conducted Immunity	IEC/EN 61000-4-6, Level 3, 10 Vrms, CW, 0.1 ... 80 MHz	A
Voltage Dips and Interruptions	IEC/EN 61000-4-11 1: Vi 230 Volts, 100% Load, Dip 100%, Duration 12 ms 2: Vi 230 Volts, 100% Load, Dip 100%, Duration < 150 ms 3: Vi 230 Volts, 100% Load, Dip 100%, Duration > 150 ms	A V1: B, VSB: A B

10.2. EMISSION

PARAMETER	DESCRIPTION / CONDITION	CRITERION
Conducted Emission	EN55022 / CISPR 22: 0.15 ... 30 MHz, QP and AVG	Class A + 6dB margin
Radiated Emission	EN55022 / CISPR 22: 30 MHz ... 1 GHz, QP	Class A + 6dB margin
Harmonic Emissions	IEC61000-3-12, Vin = 230 VAC, 50 Hz, 100% Load	Class A
Audible Noise LpA	V _{nom} , 50% I _{nom} , T _A = 25°C, at the bystander position	60 dBA
AC Flicker	IEC / EN 61000-3-3, d _{max} < 3.3%	PASS

11. SAFETY / APPROVALS

Maximum electric strength testing is performed in the factory according to UL/CSA 62368-1, IEC 62368-1. Input-to-output electric strength tests should not be repeated in the field. Bel Power Solutions will not honor any warranty claims resulting from electric strength field tests.

PARAMETER	DESCRIPTION / CONDITION	MIN	NOM	MAX	UNIT
Agency Approvals	Approved to the latest edition of the following standards: UL/CSA 62368-1, IEC 62368-1				
Isolation Strength	Input (L/N) to case (PE) Input (L/N) to output Output to case (PE)		Basic Reinforced Functional		
dc Creepage / Clearance	Primary (L/N) to protective earth (PE) Primary to secondary		According to UL/CSA 62368-1, IEC 62368-1		
Electrical Strength Test	Input to case Input to output (tested by manufacturer only)	2121 4242			VDC

12. ENVIRONMENTAL

PARAMETER	DESCRIPTION / CONDITION	MIN	NOM	MAX	UNIT
T _A	Ambient Temperature	V _{min} to V _{max} , I _{nom} , I _{SB nom} at 4000 m		+35	°C
		V _{min} to V _{max} , I _{nom} , I _{SB nom} at 1800 m		+45	°C
T _{Aext}	Extended Temp. Range	Derated output		+55	°C
T _S	Storage Temperature	Non-operational		+70	°C
	Altitude	Operational, above Sea Level (see derating)		4000	m
	Cooling	System Back Pressure		0.5	in-H ₂ O



Asia-Pacific Europe, Middle East North America
+86 755 298 85888 +353 61 225 977 +1 408 785 5200

13. MECHANICAL

PARAMETER	DESCRIPTION / CONDITION	MIN	NOM	MAX	UNIT
Dimensions	Width		69		mm
	Height		40.6		mm
	Depth		528.4		mm
<i>m</i> Weight			2.7		kg

NOTE: A 3D step file of the power supply casing is available on request.

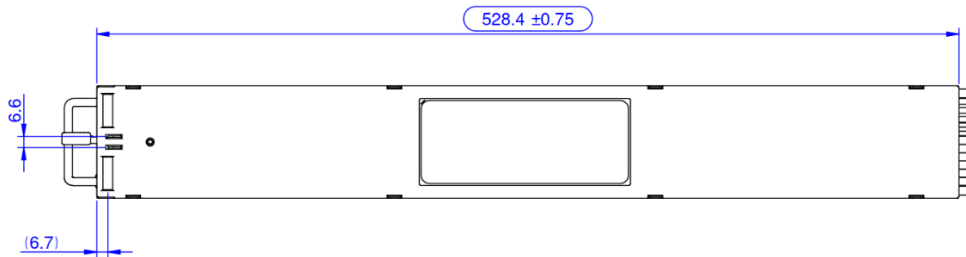

Figure 8. Top view

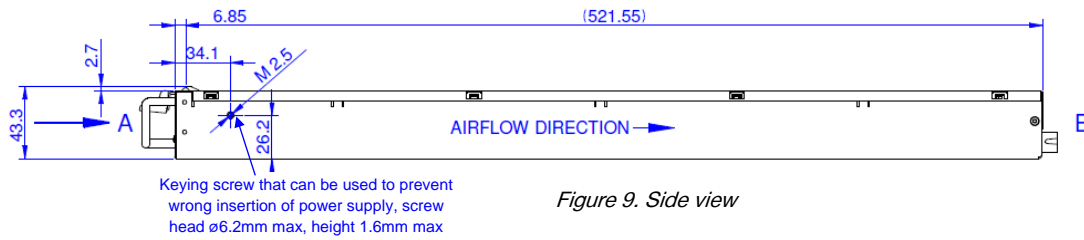

Figure 9. Side view

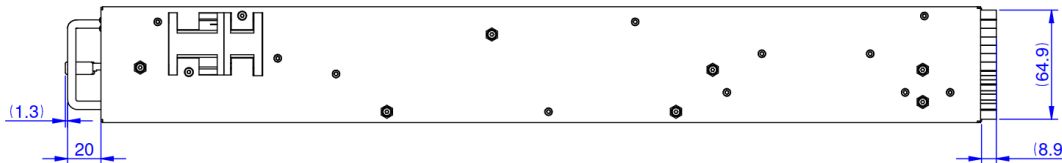

Figure 10. Bottom view

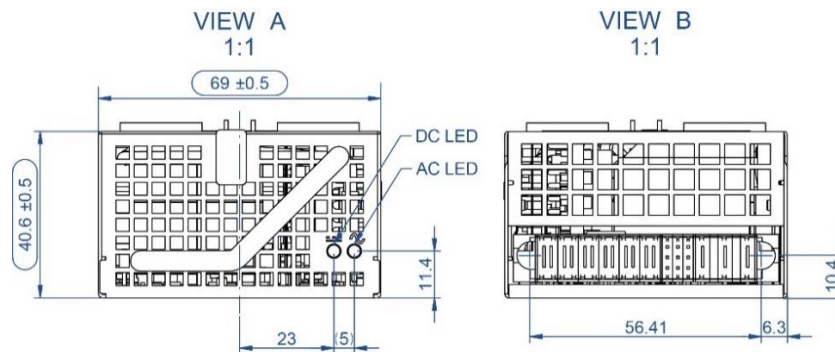

Figure 11. Front and Rear view

14. CONNECTOR

Rear side PSU connector serves as interface for input power, output power and signals. To guarantee proper mating sequence, the below noted connector P/N is required to be used.

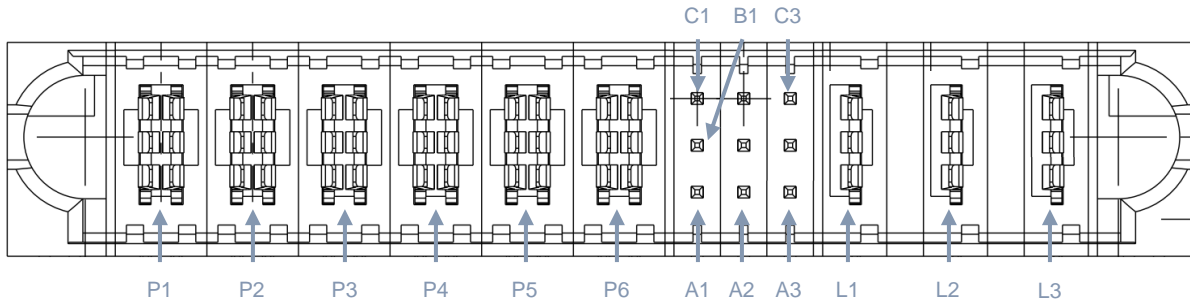

Figure 12. PSU rear side connector, view from mating side

VERSION	TYPE	MANUFACTURER	BEL P/N	MANUFACTURER P/N
PSU Connector	PWRBLADE ULTRA®	Amphenol FCI	-	10127397-07H1420LF
System Connector	PWRBLADE ULTRA®	Amphenol FCI	ZES.01164 ZES.01224	10127401-08H1420LF (Solder version) 10127400-01H1420LF (Press-Fit version)

PIN	SIGNAL NAME	DESCRIPTION	MATING SEQUENCE
L1	PE	Protective Earth	1
L2	N	AC input line (Neutral)	2
L3	L	AC input line (Line)	2
P1, P2, P3	GND	Power and ADDR0, ADDR1 return	1
P4, P5, P6	V1	+54.5 V main output	2
A1	PSKILL	Power supply kill input (lagging pin); active-high	3
B1	ACOK_L	Output signaling input voltage within operating range; active-low	2
C1	SGND	Isolated GND. CAN, PSKILL and ACOK_L are referred to it.	2
A2	ADDR0	Analog input for PSU address setting	2
B2	CAN_H	CAN-Interface, High ⁷	2
C2	CAN_L	CAN-Interface, Low ⁸	2
A3	ADDR1	Analog input for Shelf address setting ⁹	2
B3, C3	VSB	+12 V Standby output	2

Table 4. Pin assignment

⁷ With future I2C implementation will be optionally SDA

⁸ With future I2C implementation will be optionally SCL

⁹ With future I2C implementation will be optionally used as digital bidirectional share bus

15. ACCESSORIES

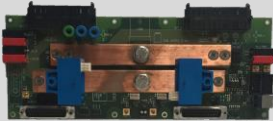
ITEM	DESCRIPTION	ORDERING PN	SOURCE
	Interface Utility Windows compatible GUI to program, control and monitor Bel products	N/A	belfuse.com/power-solutions
	Evaluation Board Evaluation board to operate 2Pcs TET4000-48-069RA	YTM.U1900.0	Bel Power Solutions

16. REVISION HISTORY

REV	DESCRIPTION	PSU PRODUCT VERSION	DATE	AUTHOR
001	Initial Draft.	V001	04-Jan-2017	WU
002	13. Corrected PSU height			
003	Adjust Specifications to align with PSU electrical design	V002	23-Oct-2017	RB
004	Formatting Changes	V003	07-Nov-2017	VS
005	Add CAN address section 0, add fan control 9.1, add mechanical outline and weight 13, add optional I2C interface 14, add P/N for mating connector 14, add adapter board P/N 15	V003	16-Jan-2018	RB/WU
006	Add DC input operating range	V005	29-Jun-2018	RB
007	Removed HVDC input operation	V006	03-Sep-2018	WU
A	Various minor updates	V006	11-Nov-2019	WU

For more information on these products consult: tech.support@psbel.com

NUCLEAR AND MEDICAL APPLICATIONS - Products are not designed or intended for use as critical components in life support systems, equipment used in hazardous environments, or nuclear control systems.

TECHNICAL REVISIONS - The appearance of products, including safety agency certifications pictured on labels, may change depending on the date manufactured. Specifications are subject to change without notice.

Компания «Life Electronics» занимается поставками электронных компонентов импортного и отечественного производства от производителей и со складов крупных дистрибьюторов Европы, Америки и Азии.

С конца 2013 года компания активно расширяет линейку поставок компонентов по направлению коаксиальный кабель, кварцевые генераторы и конденсаторы (керамические, пленочные, электролитические), за счёт заключения дистрибьюторских договоров

Мы предлагаем:

- Конкурентоспособные цены и скидки постоянным клиентам.
- Специальные условия для постоянных клиентов.
- Подбор аналогов.
- Поставку компонентов в любых объемах, удовлетворяющих вашим потребностям.
- Приемлемые сроки поставки, возможна ускоренная поставка.
- Доставку товара в любую точку России и стран СНГ.
- Комплексную поставку.
- Работу по проектам и поставку образцов.
- Формирование склада под заказчика.
- Сертификаты соответствия на поставляемую продукцию (по желанию клиента).
- Тестирование поставляемой продукции.
- Поставку компонентов, требующих военную и космическую приемку.
- Входной контроль качества.
- Наличие сертификата ISO.

В составе нашей компании организован Конструкторский отдел, призванный помогать разработчикам, и инженерам.

Конструкторский отдел помогает осуществить:

- Регистрацию проекта у производителя компонентов.
- Техническую поддержку проекта.
- Защиту от снятия компонента с производства.
- Оценку стоимости проекта по компонентам.
- Изготовление тестовой платы монтаж и пусконаладочные работы.



Тел: +7 (812) 336 43 04 (многоканальный)

Email: org@lifeelectronics.ru