



## ● Pin Layout

	1	2	3	4	5
A	T4	PVDD	DVDD	VDD	DVSS
B	XP		AVDD	AVSS	DVDD_EXT
C	XN	YP	RSTB	T1	T2
D	YN	SEL_CSB	SO	T3	IFSEL
E	ECL	EDA	SCL_SCK	SDA_SI	INT

Top view

Figure 2. Pin Layout

## ● Pin Descriptions

Pin no.	Pin Name	I/O	Description				Equivalent circuit
D1	YN	I/O	YN channel input.				D
C1	XN	I/O	XN channel input.				D
C2	YP	I/O	YP channel input.				D
B1	XP	I/O	XP channel input.				D
A1	T4	I/O	Test input / output.				D
A2	PVDD	O	Regulator output for touch screen voltage supply.				D
B3	AVDD	O	Regulator output for analog circuit.				D
A2	DVDD	I/O	Regulator output for digital circuit				D
B4	AVSS	-	Analog ground.				-
A4	VDD	-	Chip power supply.				-
A5	DVSS	-	Digital ground.				-
B5	DVDD_EXT	I	Digital power supply select. (L=internal, H=external)				A
C3	RSTB	I	Reset (Low active)				C
C4	T1	I	Test input.				A
C5	T2	I	Test input.				A
D4	T3	I	Test input.				A
D5	IFSEL	I	Host interface select. (L=4-wire SPI, H=2-wire serial)				A
D3	SO	O	2-wire serial	High impedance	4-wire SPI	Data output	O
E5	INT	O	Interrupt				E
D2	SEL_CSB	I	2-wire serial	Slave address select	4-wire SPI	Chip select	I
E4	SDA_SI	I/O	2-wire serial	Data input / output	4-wire SPI	Data input	I/O
E3	SCL_SCK	I	2-wire serial	Clock input	4-wire SPI	Clock input	I
E2	EDA	I/O	SDA for EEPROM				B
E1	ECL	I/O	SCL for EEPROM				B

(\*1) Bypass AVDD and DVDD to GND with 1.0 uF capacitor and PVDD and T4 need terminal opening.

(\*2) Digital voltage can be supplied by DVDD when DVDD\_EXT=H.

(\*3) ECL and EDA need pull-up with 4.7kΩ resistor in use case. If not use, connect to GND.

(\*4) SCL\_SCK and SDA\_SI need pull-up with over 4.7kΩ resistor and SO need terminal opening when use 2-wire serial I/F.

(\*5) Above parameters are only recommended for use. Absolute reliability is not guaranteed.

(\*6) When VDD is not supplied, state of RSTB="H" is prohibition.

● I/O equivalent circuits

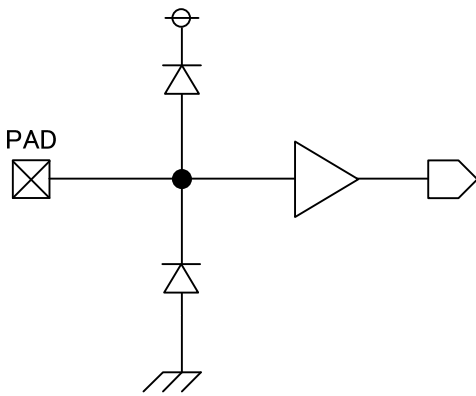

Equivalent circuit A

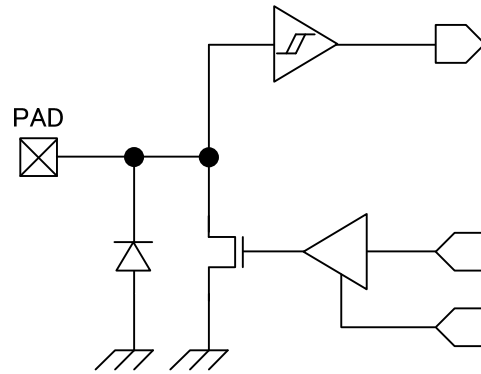

Equivalent circuit B

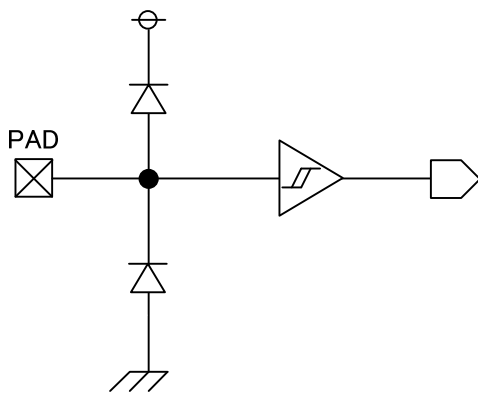

Equivalent circuit C

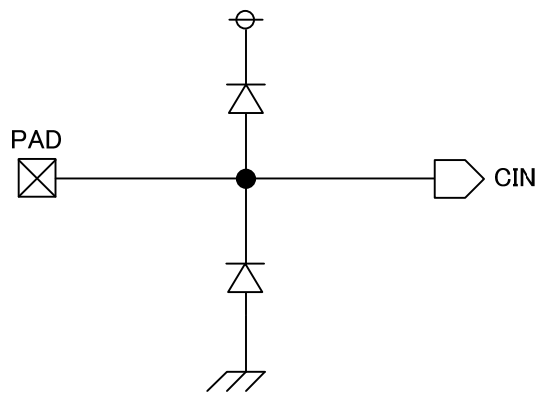

Equivalent circuit D

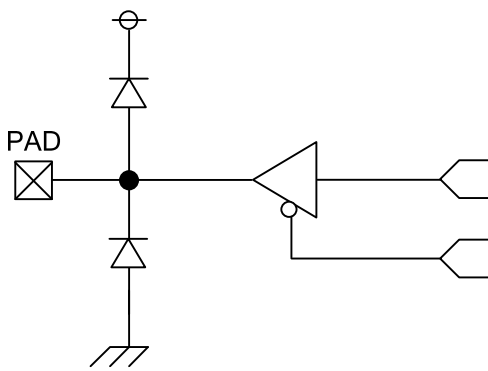

Equivalent circuit E

Figure 3. I/O equivalent circuits

**● Overview**

BU21021GUL is a resistive touch screen controller, which is capable of detecting 2 points touch with a legacy 4-wire resistive touch screen. It is composed of 32-bit CPU, 12-bit SAR A/D converter, clock oscillator, and voltage regulators power supply, and operates at a single power supply ranging from 2.7 to 3.6V. BU21021GUL is capable of detecting X/Y coordinates, touch pressure in 1 point detection mode, and a pair of X/Y coordinates in 2 point detection mode. It is also capable of recognizing multiple finger gestures from coordinate data variation and notifying to host with gesture detection flags respectively. BU21021GUL employs embedded CPU for noise filtering, coordinate calculation, gesture detection and other signal processing required on a chip.

BU21021GUL senses panel terminal voltages periodically, filters noise, then calculates coordinates in its operation mode. Host will be noticed by a interrupt signal (INT) when resister values are updated.

**1 point detection**

Touch detection and touch pressure detection are processed on chip, and BU21021GUL operates as a legacy resistive touch controller employing 4-wire resistive touch screen.

BU21021GUL has 2 point touch detection function, which prevents itself from common misdetection of single 'midpoint' coordinate output.

**2 points detection**

2 point detection is held by monitoring electric condition of a touch sensor and calculating coordinates on each axis. The process is different from legacy 1 point touch detection, therefore BU21021GUL requires setup of panel parameter in advance.

BU21021GUL automatically detects ether 1 point or 2 points touch input.

**Gesture detection**

BU21021GUL is able to detect 1 point flick gesture for 4 directions and 2 point ZOOM IN/OUT, PINCH/SPREAD and rotate gestures respectively. Gesture detection events are reported to host as detection flags and interrupt. Each of gesture detection sensitivities can be set as register parameters respectively.

(Note) Gesture flags only repot its events. Operation speed and movement have to be calculate on host using coordinate data.

**Auto power on / off function**

Auto power off function will power off to sleep condition in order to reduce power consumption when no touch input is detected. BU21021GUL will automatically change to operation state when touch event is detected in sleep state.

This function is able to be enabled / disabled, and threshold level of sleep state transition is able to be set by registers.

**Host interface**

BU21021GUL works as slave device of HOST MCU connected 2-wire serial bus or 4-wire SPI.

It is selectable by IFSEL pin condition.

(IFSEL=GND : 4-wire SPI, IFSEL=VDD : 2-wire serial bus)

**EEPROM**

Firmware has to be downloaded on BU21021GUL in order to realize these functions. The file size of firmware is 16kB (16384 bytes). A "HOST interface" and "external EEPROM" can be chosen as the download method.

**DVDD external supply setup**

In the case there exists 1.8V power supply on application system, the external 1.8V supply can be applicable to DVDD in order to reduce sleep power consumption to 10uA.

### ●Block Diagram

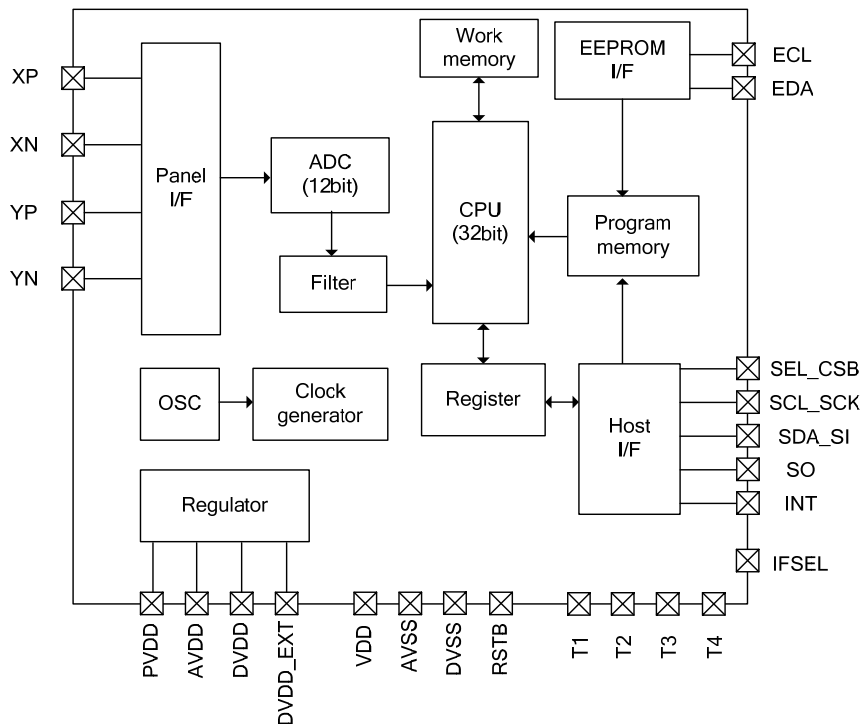

Figure 4. Block Diagram

### ●Description of Blocks

- Screen-I/F : 4-wire touch screen interface
- ADC : 12-bit SAR A/D converter
- OSC : 20MHz oscillator for internal block
- Regulator : Internal power supply.  
DVDD can be supplied from external
- Clock generator : System clock and internal timing generation
- CPU : Noise filtering, dual touch detection and touch coordinates generation
- Work memory : CPU work memory
- Program memory : CPU program memory
- EEPROM-I/F : External EEPROM-I/F for CPU program memory downloads
- Host-I/F : 4-wire SPI I/F / 2-wire serial bus I/F
- Filter : Median average filter (Maximum 16 data)

### ● Absolute Maximum Ratings

Parameter	Symbol	Rating	Unit	Conditions
Power-supply voltage	VDD	-0.3 to 4.5	V	
Input voltage	VIN	VSS-0.3 to VDD+0.3	V	
Power dissipation	Pd	910 <sup>*1</sup>	mW	
Storage temperature range	Tstg	-50 to 125	°C	

\*1 Ambient temperature reduces a permission loss by 9.10mW per case more than 25 degree Celsius, 1degree Celsius. Condition: Assembly on the Epoxy-Glass (50x58x1.75mm)

### ● Recommended Operating Conditions

Parameter	Symbol	Rating			Unit	Conditions
		Min	Typ	Max		
Power-supply voltage	VDD	2.7	3.0	3.6	V	
Digital power-supply voltage	DVDD	1.62	1.80	1.98	V	DVDD_EXT = H
Operating temperature range	Topr	-20	25	85	°C	

### ● Electrical Characteristics

At Ta = 25°C, VDD = 3.0V, unless otherwise noted.

Parameter	Symbol	Rating			Unit	Conditions
		Min	Typ	Max		
Low-level input voltage	VIL	VSS-0.5	-	0.2xVDD	V	
High-level input voltage	VIH	0.8xVDD	-	VDD+0.5	V	
Low-level output voltage	VOL	-	-	VSS+0.4	V	
High-level output voltage	VOH	VDD-0.4	-	-	V	
Standby current	Ist	-	-	5	uA	RSTB=L
Sleep current1	Icc1	-	60	100	uA	DVDD_EXT=L
Sleep current2	Icc2	-	10	20	uA	DVDD_EXT=H (*1)
Operating current	Idd	-	4	8	mA	No load
Clock frequency	Freq	15	20	24	MHz	

\*1 The supply of digital power (1.8V) is needed from the terminal DVDD.

●HOST-I/F timing specification (4-wire SPI)

(Note: SCK=SCL\_SCK, SI=SDA\_SI, CSB=SEL\_CSB and SO=SO)

4-wire SPI has the burst write and burst read.

The automatic address increment is done until 0x5F. After address 0x5F is accessed, it is not changed.

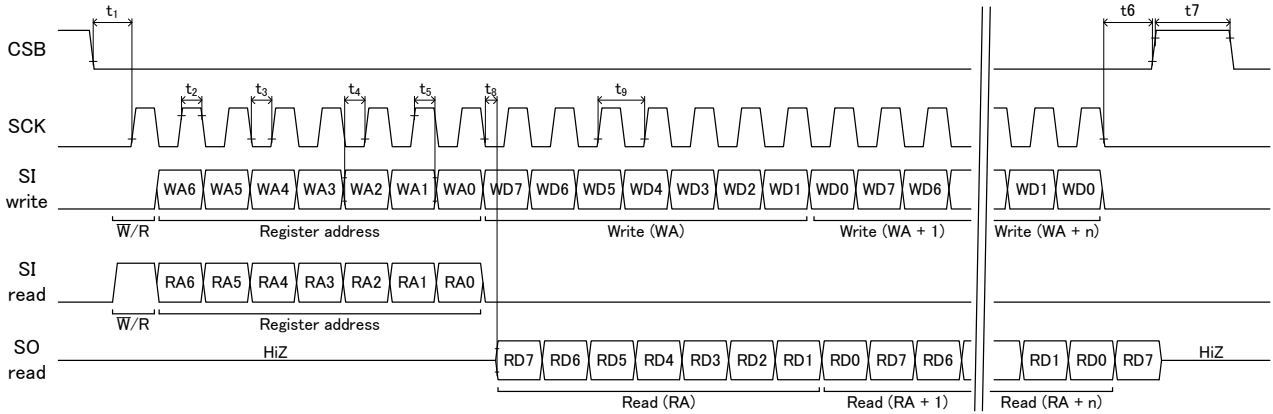

Figure 5. Timing specification (4-wire SPI)

Table 1. Timing Requirements: 4-wire SPI at VDD = 3.0V, Ta = 25°C

Parameter	Symbol	Rating			Unit	Conditions
		Min	Typ	Max		
CSB setup time	t <sub>1</sub>	30	-	-	ns	
'H' width of SCK	t <sub>2</sub>	30	-	-	ns	
'L' width of SCK	t <sub>3</sub>	30	-	-	ns	
SI setup time	t <sub>4</sub>	20	-	-	ns	
SI holding time	t <sub>5</sub>	20	-	-	ns	
CSB holding time	t <sub>6</sub>	20	-	-	ns	
'H' width of CSB	t <sub>7</sub>	50	-	-	ns	
SO output delay time	t <sub>8</sub>	-	-	15	ns	
SCK frequency	t <sub>9</sub>	-	-	15	MHz	

●HOST-I/F timing specification (2-wire serial)

(Note: SCL=SCL\_SCK, SDA=SDA\_SI)

2-wire serial has the burst write and burst read.

The automatic address increment is done until 0x5F. After address 0x5F is accessed, it is not changed.

This 2-wire serial I/F is not corresponded to re-start command. Send start condition after send stop condition.

The slave address of 2-wire serial is B8h / BAh which is decided by the state of the terminal SEL\_CSb.

- SEL\_CSb = "L" : Slave Address = B8h ( 7bit = 5Ch + W/R bit )
- SEL\_CSb = "H" : Slave Address = BAh ( 7bit = 5Dh + W/R bit )

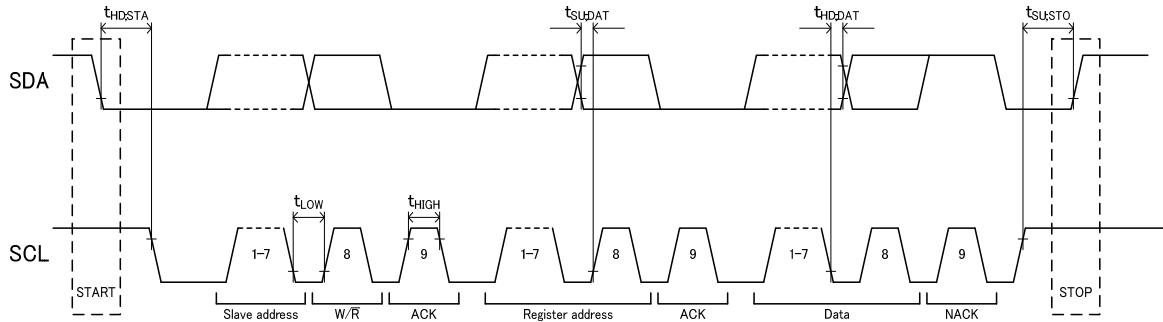

Figure 6. Timing specification (2-wire serial)

Table 2. Timing Requirements: 2-wire serial at VDD = 3.0V, Ta = 25°C

Parameter	Symbol	Rating			Unit	Condition
		Min	Typ	Max		
SCL clock frequency	f <sub>SCL</sub>	0	-	400	kHz	
START hold time	t <sub>HD:STA</sub>	0.6	-	-	us	
"L" width of SCL	t <sub>LOW</sub>	1.3	-	-	us	
"H" width of SCL	t <sub>HIGH</sub>	0.6	-	-	us	
Data hold time	t <sub>HD:DAT</sub>	0.1	-	-	us	
Data setup time	t <sub>SU:DAT</sub>	0.1	-	-	us	
STOP setup time	t <sub>SU:STO</sub>	0.6	-	-	us	

• Write Protocol



• Read Protocol

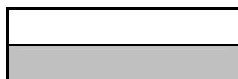
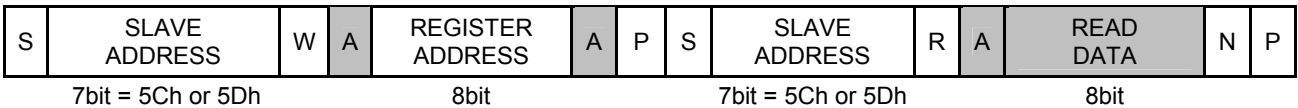

- S : START condition
- P : STOP condition
- R : data direction READ (SDA HIGH)
- W : data direction WRITE (SDA LOW)
- A : acknowledge (SDA LOW)
- N : not acknowledge (SDA HIGH)

Figure 7. Read/Write Protocol



● Typical Application circuit

BU21021GUL has two selectable host interfaces (4-wire SPI and 2-wire serial).  
The figure below shows the example of circuit when each interface is used.  
(Show by the terminal display though BU21021GUL is CSP package.)

- Option(\*1) For reject and reduce the noise from touch screen / LCD module or wiring.
- Option(\*2) It is not necessary to mount EEPROM when firmware download setting is host.  
Connect to ECL/EDA to VSS.  
Please connect EEPROM when firmware download setting is EEPROM.
- Option(\*3) In using with Slave address = BAh case, connect SEL\_CSB to VDD.

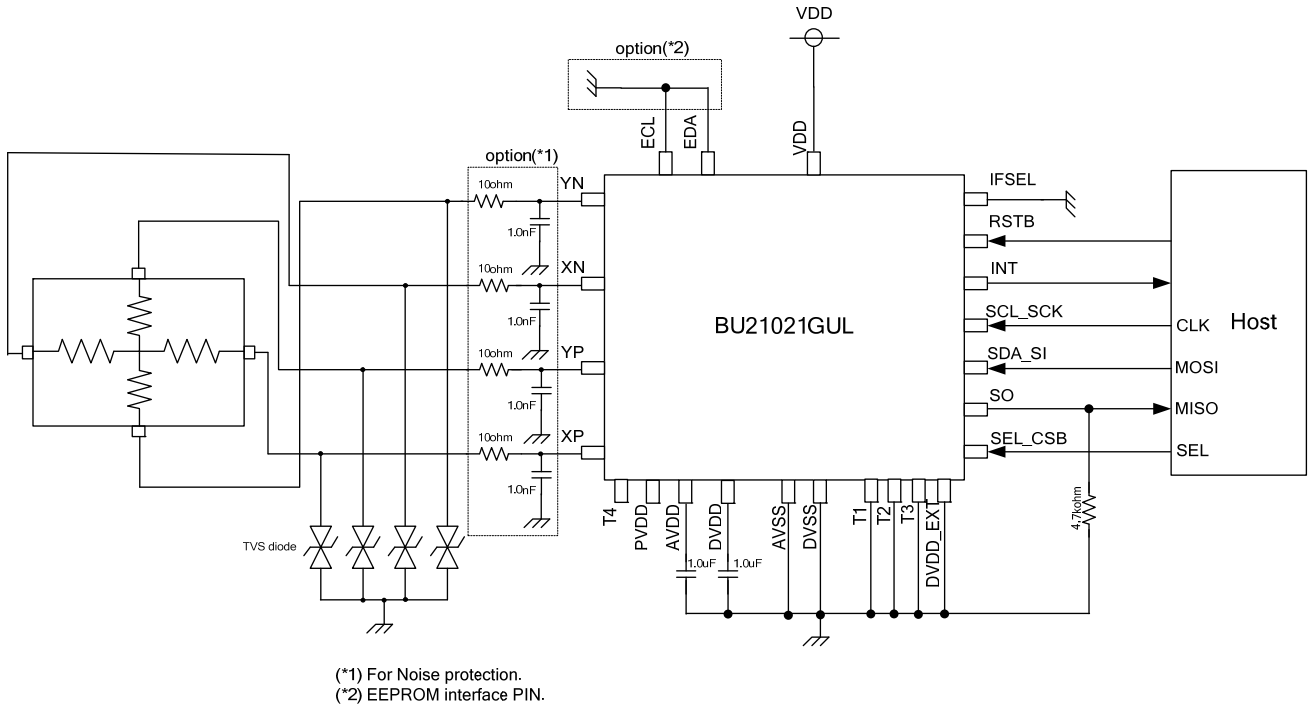

Figure 8. Application circuit 1 (4-wire SPI)

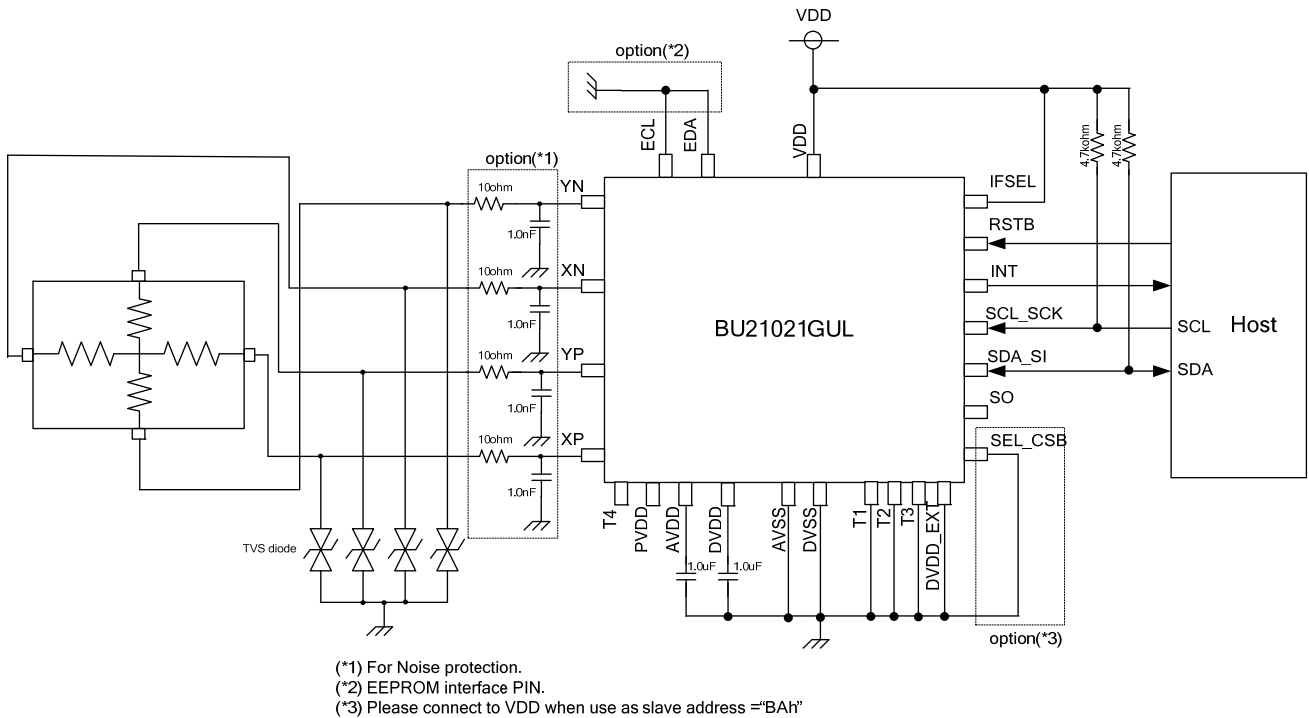
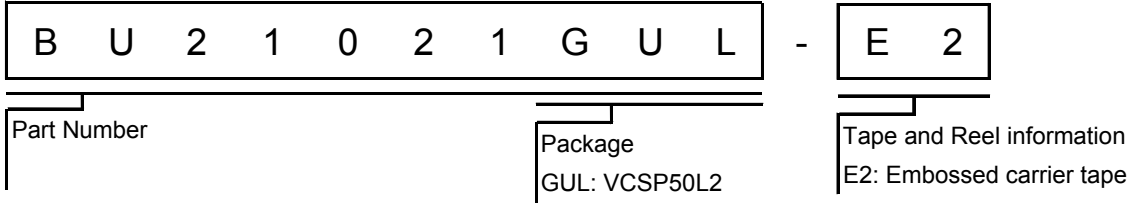

Figure 9. Application circuit 2 (2-wire serial bus)

●Ordering Information



●Physical Dimension Tape and Reel Information

VCSP50L2(BU21021GUL)

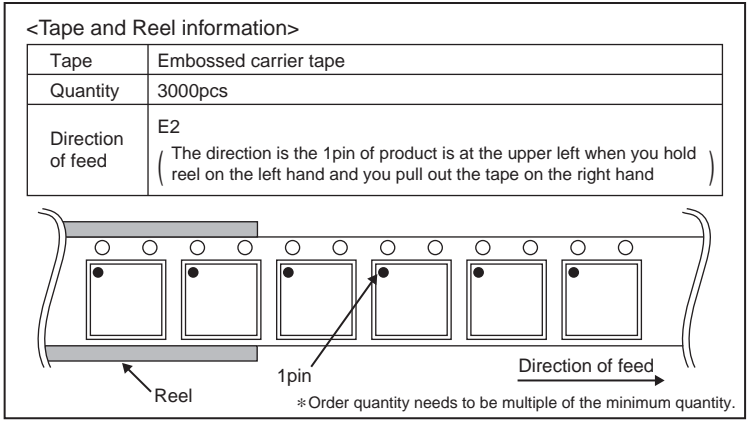
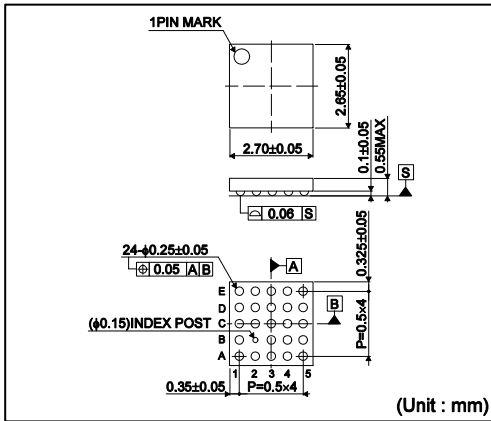

●Marking Diagram(TOP VIEW)

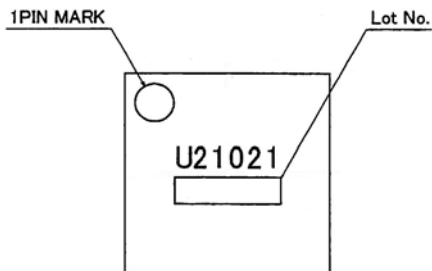

# Notice

## ●General Precaution

- 1) Before you use our Products, you are requested to carefully read this document and fully understand its contents. ROHM shall not be in any way responsible or liable for failure, malfunction or accident arising from the use of any ROHM's Products against warning, caution or note contained in this document.
- 2) All information contained in this document is current as of the issuing date and subject to change without any prior notice. Before purchasing or using ROHM's Products, please confirm the latest information with a ROHM sales representative.

## ●Precaution on using ROHM Products

- 1) Our Products are designed and manufactured for application in ordinary electronic equipments (such as AV equipment, OA equipment, telecommunication equipment, home electronic appliances, amusement equipment, etc.). If you intend to use our Products in devices requiring extremely high reliability (such as medical equipment, transport equipment, traffic equipment, aircraft/spacecraft, nuclear power controllers, fuel controllers, car equipment including car accessories, safety devices, etc.) and whose malfunction or failure may cause loss of human life, bodily injury or serious damage to property ("Specific Applications"), please consult with the ROHM sales representative in advance. Unless otherwise agreed in writing by ROHM in advance, ROHM shall not be in any way responsible or liable for any damages, expenses or losses incurred by you or third parties arising from the use of any ROHM's Products for Specific Applications.
- 2) ROHM designs and manufactures its Products subject to strict quality control system. However, semiconductor products can fail or malfunction at a certain rate. Please be sure to implement, at your own responsibilities, adequate safety measures including but not limited to fail-safe design against the physical injury, damage to any property, which a failure or malfunction of our Products may cause. The following are examples of safety measures:
  - [a] Installation of protection circuits or other protective devices to improve system safety
  - [b] Installation of redundant circuits to reduce the impact of single or multiple circuit failure
- 3) Our Products are designed and manufactured for use under standard conditions and not under any special or extraordinary environments or conditions, as exemplified below. Accordingly, ROHM shall not be in any way responsible or liable for any damages, expenses or losses arising from the use of any ROHM's Products under any special or extraordinary environments or conditions. If you intend to use our Products under any special or extraordinary environments or conditions (as exemplified below), your independent verification and confirmation of product performance, reliability, etc. prior to use, must be necessary:
  - [a] Use of our Products in any types of liquid, including water, oils, chemicals, and organic solvents
  - [b] Use of our Products outdoors or in places where the Products are exposed to direct sunlight or dust
  - [c] Use of our Products in places where the Products are exposed to sea wind or corrosive gases, including Cl<sub>2</sub>, H<sub>2</sub>S, NH<sub>3</sub>, SO<sub>2</sub>, and NO<sub>2</sub>
  - [d] Use of our Products in places where the Products are exposed to static electricity or electromagnetic waves
  - [e] Use of our Products in proximity to heat-producing components, plastic cords, or other flammable items
  - [f] Sealing or coating our Products with resin or other coating materials
  - [g] Use of our Products without cleaning residue of flux (even if you use no-clean type fluxes, cleaning residue of flux is recommended); or Washing our Products by using water or water-soluble cleaning agents for cleaning residue after soldering
  - [h] Use of the Products in places subject to dew condensation
- 4) The Products are not subject to radiation-proof design.
- 5) Please verify and confirm characteristics of the final or mounted products in using the Products.
- 6) In particular, if a transient load (a large amount of load applied in a short period of time, such as pulse) is applied, confirmation of performance characteristics after on-board mounting is strongly recommended. Avoid applying power exceeding normal rated power; exceeding the power rating under steady-state loading condition may negatively affect product performance and reliability.
- 7) De-rate Power Dissipation (Pd) depending on Ambient temperature (Ta). When used in sealed area, confirm the actual ambient temperature.
- 8) Confirm that operation temperature is within the specified range described in the product specification.
- 9) ROHM shall not be in any way responsible or liable for failure induced under deviant condition from what is defined in this document.

● **Precaution for Mounting / Circuit board design**

- 1) When a highly active halogenous (chlorine, bromine, etc.) flux is used, the residue of flux may negatively affect product performance and reliability.
- 2) In principle, the reflow soldering method must be used; if flow soldering method is preferred, please consult with the ROHM representative in advance.

For details, please refer to ROHM Mounting specification

● **Precautions Regarding Application Examples and External Circuits**

- 1) If change is made to the constant of an external circuit, please allow a sufficient margin considering variations of the characteristics of the Products and external components, including transient characteristics, as well as static characteristics.
- 2) You agree that application notes, reference designs, and associated data and information contained in this document are presented only as guidance for Products use. Therefore, in case you use such information, you are solely responsible for it and you must exercise your own independent verification and judgment in the use of such information contained in this document. ROHM shall not be in any way responsible or liable for any damages, expenses or losses incurred by you or third parties arising from the use of such information.

● **Precaution for Electrostatic**

This Product is electrostatic sensitive product, which may be damaged due to electrostatic discharge. Please take proper caution in your manufacturing process and storage so that voltage exceeding the Products maximum rating will not be applied to Products. Please take special care under dry condition (e.g. Grounding of human body / equipment / solder iron, isolation from charged objects, setting of Ionizer, friction prevention and temperature / humidity control).

● **Precaution for Storage / Transportation**

- 1) Product performance and soldered connections may deteriorate if the Products are stored in the places where:
  - [a] the Products are exposed to sea winds or corrosive gases, including Cl<sub>2</sub>, H<sub>2</sub>S, NH<sub>3</sub>, SO<sub>2</sub>, and NO<sub>2</sub>
  - [b] the temperature or humidity exceeds those recommended by ROHM
  - [c] the Products are exposed to direct sunshine or condensation
  - [d] the Products are exposed to high Electrostatic
- 2) Even under ROHM recommended storage condition, solderability of products out of recommended storage time period may be degraded. It is strongly recommended to confirm solderability before using Products of which storage time is exceeding the recommended storage time period.
- 3) Store / transport cartons in the correct direction, which is indicated on a carton with a symbol. Otherwise bent leads may occur due to excessive stress applied when dropping of a carton.
- 4) Use Products within the specified time after opening a humidity barrier bag. Baking is required before using Products of which storage time is exceeding the recommended storage time period.

● **Precaution for Product Label**

QR code printed on ROHM Products label is for ROHM's internal use only.

● **Precaution for Disposition**

When disposing Products please dispose them properly using an authorized industry waste company.

● **Precaution for Foreign Exchange and Foreign Trade act**

Since our Products might fall under controlled goods prescribed by the applicable foreign exchange and foreign trade act, please consult with ROHM representative in case of export.

● **Precaution Regarding Intellectual Property Rights**

- 1) All information and data including but not limited to application example contained in this document is for reference only. ROHM does not warrant that foregoing information or data will not infringe any intellectual property rights or any other rights of any third party regarding such information or data. ROHM shall not be in any way responsible or liable for infringement of any intellectual property rights or other damages arising from use of such information or data.:
- 2) No license, expressly or implied, is granted hereby under any intellectual property rights or other rights of ROHM or any third parties with respect to the information contained in this document.

●Other Precaution

- 1) The information contained in this document is provided on an "as is" basis and ROHM does not warrant that all information contained in this document is accurate and/or error-free. ROHM shall not be in any way responsible or liable for any damages, expenses or losses incurred by you or third parties resulting from inaccuracy or errors of or concerning such information.
- 2) This document may not be reprinted or reproduced, in whole or in part, without prior written consent of ROHM.
- 3) The Products may not be disassembled, converted, modified, reproduced or otherwise changed without prior written consent of ROHM.
- 4) In no event shall you use in any way whatsoever the Products and the related technical information contained in the Products or this document for any military purposes, including but not limited to, the development of mass-destruction weapons.
- 5) The proper names of companies or products described in this document are trademarks or registered trademarks of ROHM, its affiliated companies or third parties.



Компания «Life Electronics» занимается поставками электронных компонентов импортного и отечественного производства от производителей и со складов крупных дистрибьюторов Европы, Америки и Азии.

С конца 2013 года компания активно расширяет линейку поставок компонентов по направлению коаксиальный кабель, кварцевые генераторы и конденсаторы (керамические, пленочные, электролитические), за счёт заключения дистрибьюторских договоров

Мы предлагаем:

- Конкуренспособные цены и скидки постоянным клиентам.
- Специальные условия для постоянных клиентов.
- Подбор аналогов.
- Поставку компонентов в любых объемах, удовлетворяющих вашим потребностям.
- Приемлемые сроки поставки, возможна ускоренная поставка.
- Доставку товара в любую точку России и стран СНГ.
- Комплексную поставку.
- Работу по проектам и поставку образцов.
- Формирование склада под заказчика.
- Сертификаты соответствия на поставляемую продукцию (по желанию клиента).
- Тестирование поставляемой продукции.
- Поставку компонентов, требующих военную и космическую приемку.
- Входной контроль качества.
- Наличие сертификата ISO.

В составе нашей компании организован Конструкторский отдел, призванный помогать разработчикам, и инженерам.

Конструкторский отдел помогает осуществить:

- Регистрацию проекта у производителя компонентов.
- Техническую поддержку проекта.
- Защиту от снятия компонента с производства.
- Оценку стоимости проекта по компонентам.
- Изготовление тестовой платы монтаж и пусконаладочные работы.



Тел: +7 (812) 336 43 04 (многоканальный)

Email: [org@lifeelectronics.ru](mailto:org@lifeelectronics.ru)