



Main

Range of product	Magelis GTO
Product or component type	Advanced touchscreen panel
Display colour	65536 colours
Display size	5.7 inch
Supply	External source
Operating system	Magelis
Battery type	Lithium battery for internal RAM, autonomy: 100 days, charging time = 5 d, battery life = 10 yr

Complementary

Terminal type	Touchscreen display
Display type	Backlit colour TFT LCD
Display resolution	320 x 240 pixels QVGA
Touch sensitive zone	1024 x 1024
Touch panel	Resistive film, 1000000 cycles
Backlight lifespan	50000 hours (white) at 77 °F (25 °C)
Brightness	16 levels - control by touch panel 16 levels - control by software
Character font	ASCII (European characters) Chinese (simplified Chinese) Japanese (ANK, Kanji) Korean Taiwanese (traditional Chinese)
[Us] rated supply voltage	24 V DC
Supply voltage limits	19.2...28.8 V
Inrush current	<= 30 A
Power consumption in W	<= 10.5 W <= 6.5 W (when power is not supplied to external devices) <= 4.5 W (when backlight is OFF) <= 5 W (when backlight is dimmed)
Local signalling	Status LED (orange) flashing software starting up Status LED (green) steady offline Status LED (green) steady operating Status LED (red) steady power supply (ON) Status LED (clear) faded power supply (OFF) COM2 LED (yellow) steady data is being transmitted COM2 LED (yellow) faded no data transmission SD card LED (green) steady card is inserted SD card LED (green) faded card is not inserted or is not being accessed
Software designation	Vijeo Designer configuration software >= V6.1
Memory description	96 MB flash (EPROM)
Data backed up	512 kB internal RAM (SRAM)
Data storage equipment	SD card <= 32 GB SDHC card <= 32 GB
Downloadable protocols	Modbus Schneider Electric Modicon Third party protocols Mitsubishi Melsec Third party protocols Omron Sysmac Third party protocols Rockwell Automation Allen-Bradley Third party protocols Siemens Simatic Uni-TE Schneider Electric Modicon Modbus Plus Schneider Electric Modicon FIPWAY Schneider Electric Modicon Modbus TCP Schneider Electric Modicon
Integrated connection type	COM1 serial link SUB-D 9, interface: RS232C, transmission rate: 2400...115200 bps

The information provided in this documentation contains general descriptions and/or technical characteristics of the products contained herein. This documentation is not intended as a substitute for and is not to be used for determining suitability or reliability of these products for specific user applications. It is the duty of any such user or integrator to perform the appropriate and complete risk analysis, evaluation and testing of the products with respect to the relevant specific application or use thereof. Neither Schneider Electric Industries SAS nor any of its affiliates or subsidiaries shall be responsible or liable for misuse of the information contained herein.

COM2 serial link RJ45, interface: RS485, transmission rate: 2400...115200 bps
 COM2 serial link RJ45, interface: RS485, transmission rate: 187.5 kbps compatible with Siemens MPI
 Ethernet RJ45, interface: 10BASE-T/100BASE-TX
 Ethernet RJ45, interface: IEEE 802.3
 USB 2.0 type A
 USB 2.0 type mini B

Product mounting	Flush mounting
Fixing mode	By 4 screw clamps
Front material	PPT
Enclosure material	PPT
Type of cooling	Natural convection
Width	6.67 in (169.5 mm)
Height	5.39 in (137 mm)
Depth	2.34 in (59.5 mm)
Product weight	1.76 lb(US) (0.8 kg)

Environment

standards	EN 61131-2 IEC 61000-6-2 UL 508
product certifications	CE C-Tick CULus KCC
ambient air temperature for operation	32...131 °F (0...55 °C)
ambient air temperature for storage	-4...140 °F (-20...60 °C)
relative humidity	10...90 % without condensation
operating altitude	< 6561.68 ft (2000 m)
IP degree of protection	IP20 rear panel conforming to IEC 60529 IP65 front panel conforming to IEC 60529
NEMA degree of protection	NEMA 4X front panel (indoor use)
shock resistance	147 m/s ² 3 chocks in each direction X, Y and Z conforming to EN/IEC 61131-2
vibration resistance	3.5 mm (f = 5...9 Hz) conforming to EN/IEC 61131-2 X, Y, Z directions for 10 cycles (approx. 100 min) 1 gn (f = 9...150 Hz) conforming to EN/IEC 61131-2 X, Y, Z directions for 10 cycles (approx. 100 min)
resistance to electrostatic discharge	6 kV contact discharge conforming to IEC 61000-4-2 level 3

Offer Sustainability

Green Premium product	Green Premium product
Compliant - since 1348 - Schneider Electric declaration of conformity	Compliant - since 1348 - Schneider Electric declaration of conformity
Reference not containing SVHC above the threshold	Reference not containing SVHC above the threshold
Available	Available
Available	Available
WARNING: Cancer and Reproductive Harm - www.P65Warnings.ca.gov	WARNING: Cancer and Reproductive Harm - www.P65Warnings.ca.gov

Contractual warranty

Warranty period	18 months
-----------------	-----------

Dimensions

External Dimensions

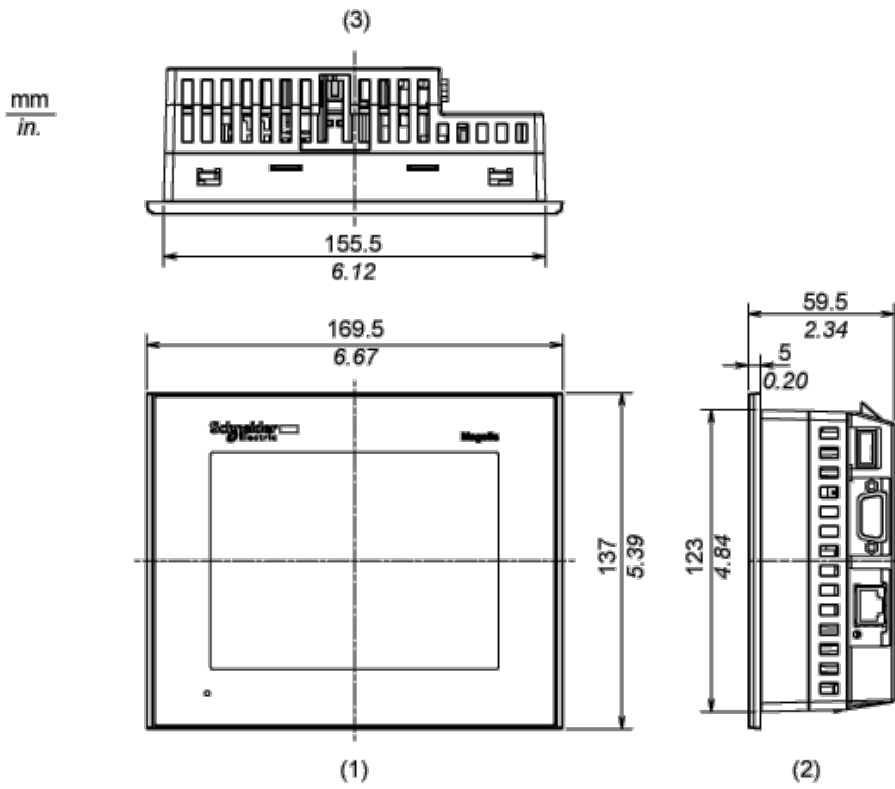

- 1 Front
- 2 Right Side
- 3 Top

Installation with Installation Fasteners

mm
in.

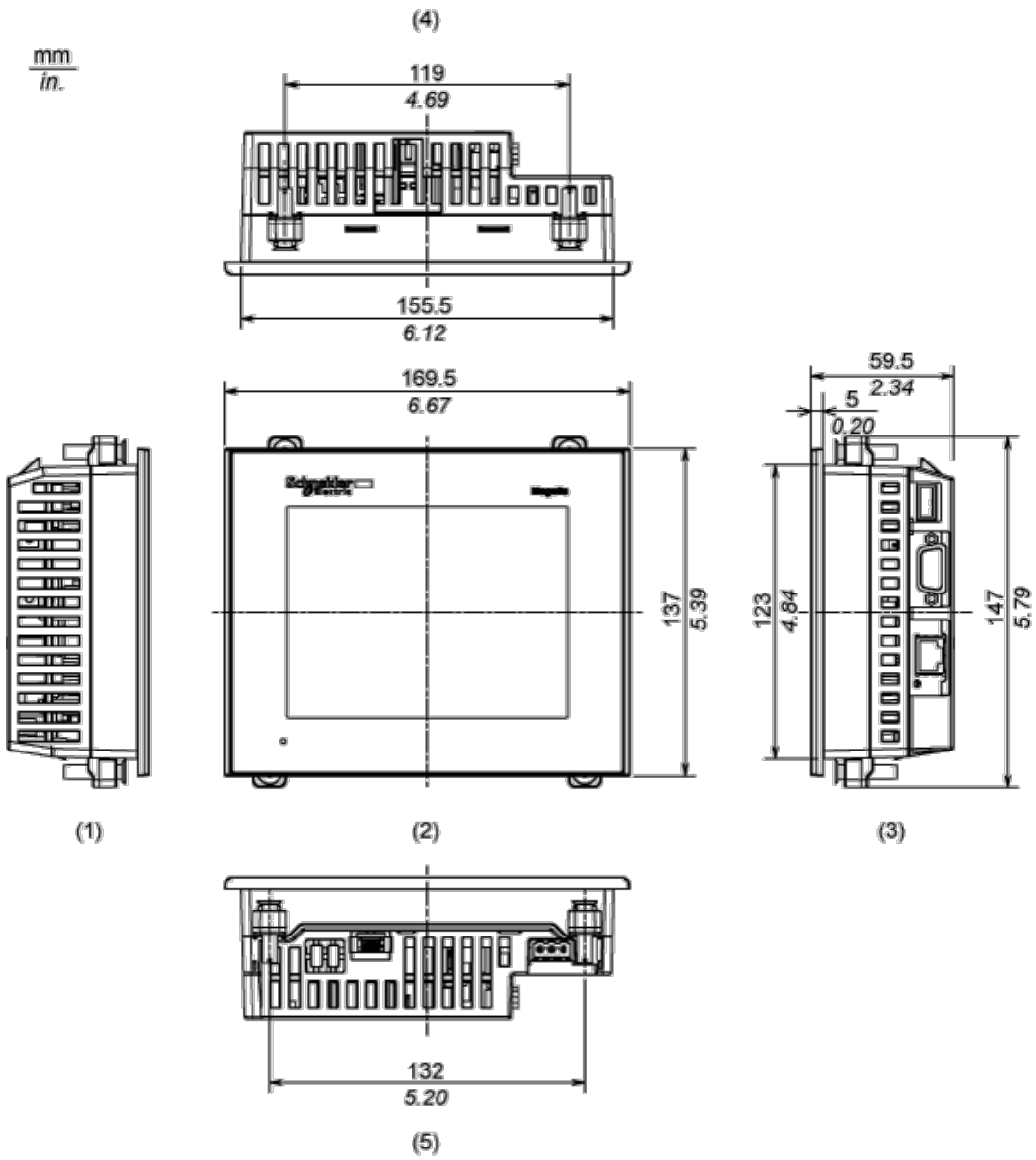

- 1 Left Side
- 2 Front
- 3 Right Side
- 4 Top
- 5 Bottom

Dimensions with Cables

mm
in.

(4)

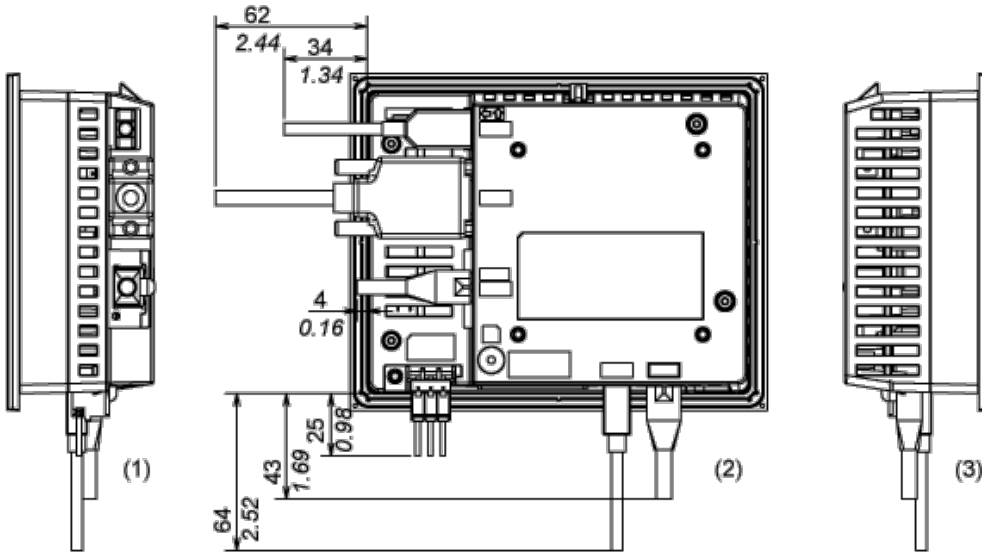
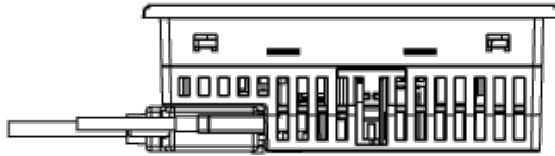

(5)

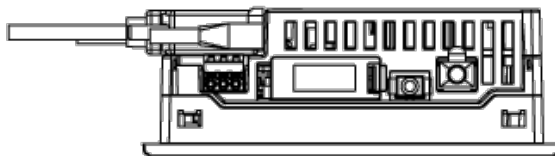

- 1 Left Side
- 2 Rear
- 3 Right Side
- 4 Top
- 5 Bottom

Mounting

Panel Cut Dimensions

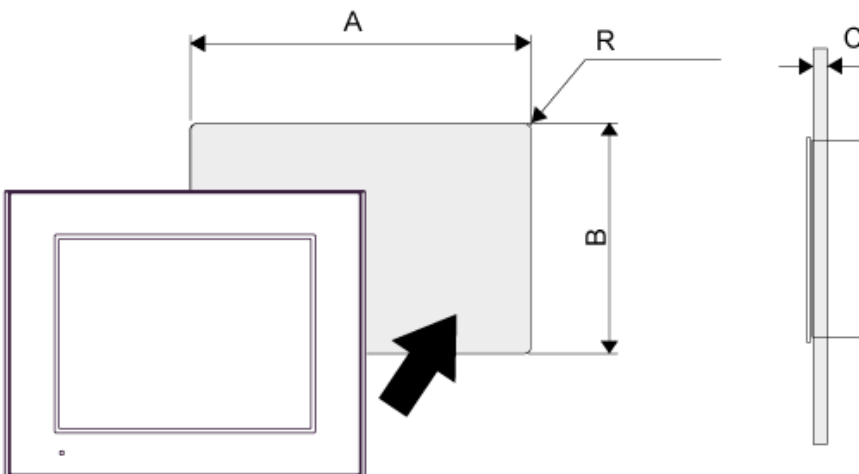

A		B		C		R	
mm	in.	mm	in.	mm	in.	mm	in.
156 (+1, -0)	6.14 (+0.04, -0)	123.5 (+1, -)	4.86 (+0.04, -0)	1.6...5	0.06...0.2	3 max.	0.12 max.

Installation Fastener Dimensions

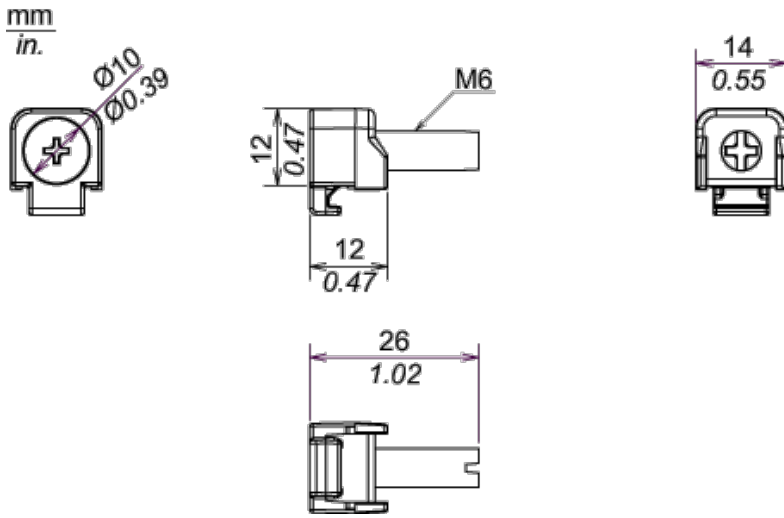

Installation Requirements

Mounting Angle

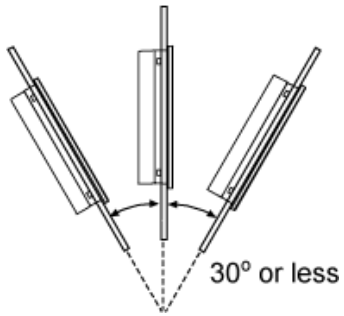

When installing the panel in a slanted position with an incline more than 30°, the ambient temperature must not exceed 40 °C (104 °F). You may need to use forced air cooling (fan,A/C) to ensure the ambient operating temperature is 40°C or less (104 °F or less).

Clearance

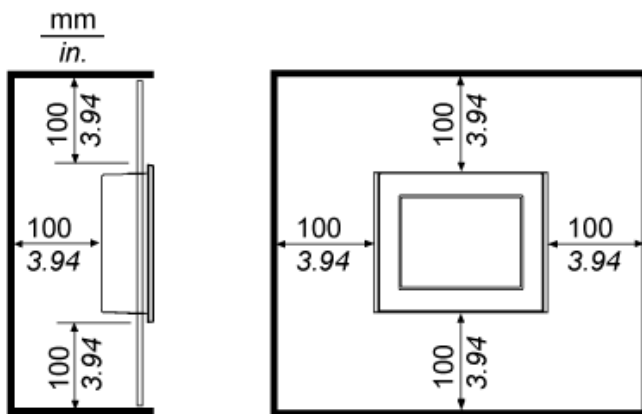

Компания «Life Electronics» занимается поставками электронных компонентов импортного и отечественного производства от производителей и со складов крупных дистрибьюторов Европы, Америки и Азии.

С конца 2013 года компания активно расширяет линейку поставок компонентов по направлению коаксиальный кабель, кварцевые генераторы и конденсаторы (керамические, пленочные, электролитические), за счёт заключения дистрибьюторских договоров

Мы предлагаем:

- Конкурентоспособные цены и скидки постоянным клиентам.
- Специальные условия для постоянных клиентов.
- Подбор аналогов.
- Поставку компонентов в любых объемах, удовлетворяющих вашим потребностям.
- Приемлемые сроки поставки, возможна ускоренная поставка.
- Доставку товара в любую точку России и стран СНГ.
- Комплексную поставку.
- Работу по проектам и поставку образцов.
- Формирование склада под заказчика.
- Сертификаты соответствия на поставляемую продукцию (по желанию клиента).
- Тестирование поставляемой продукции.
- Поставку компонентов, требующих военную и космическую приемку.
- Входной контроль качества.
- Наличие сертификата ISO.

В составе нашей компании организован Конструкторский отдел, призванный помогать разработчикам, и инженерам.

Конструкторский отдел помогает осуществить:

- Регистрацию проекта у производителя компонентов.
- Техническую поддержку проекта.
- Защиту от снятия компонента с производства.
- Оценку стоимости проекта по компонентам.
- Изготовление тестовой платы монтаж и пусконаладочные работы.



Тел: +7 (812) 336 43 04 (многоканальный)

Email: org@lifeelectronics.ru