

FEATURES

- 0.65V to 2.5V Single-supply operation
- AC-coupled Non-inverting and Inverting configurations supplied
- Fully Assembled and Tested
- 2mm x 2mm 2-layer demo board

DESCRIPTION

The demo boards for the TS1002 and the TS1004 are completely assembled and tested circuit boards that can be used for evaluating the TS1002 and the TS1004, respectively. The TS1002 and the TS1004 are the industry's first and only dual and quad single-supply, precision CMOS operational amplifiers fully specified to operate at 0.8V while consuming less than 0.6µA supply current per amplifier. Optimized for ultra-long-life battery-powered applications, the TS1002 and the TS1004 join Touchstone's TS1001 operational amplifier in the "NanoWatt Analog™" high-performance analog integrated circuits portfolio. Both op amps exhibit a typical offset voltage of 0.5mV, a typical input bias current of 25pA, and rail-to-rail input and output stages. The TS1002 and the TS1004 can operate from single-supply voltages from 0.65V to 2.5V.

The TS1002 and the TS1004 are fully specified at $V_{DD} = 0.8V$ and over the industrial temperature range ($-40^{\circ}C$ to $+85^{\circ}C$). The TS1002 is available in PCB-space saving 8-lead MSOP surface-mount packages. The TS1004 is available in a 14-pin TSSOP package.

Product data sheets and additional documentation can be found on factory web site at www.touchstonesemi.com.

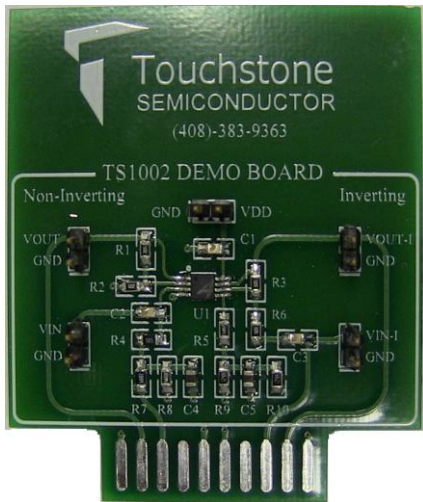

Figure 1. TS1002 Evaluation Board

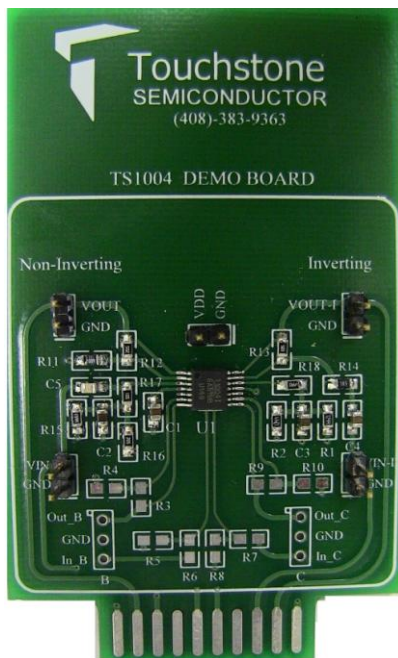

Figure 2. TS1004 Evaluation Board

Ordering Information

| Order Number | Description |
|--------------|-------------------------------|
| TS1002DB | TS1002 Dual Op Amp Demo Board |
| TS1004DB | TS1004 Quad Op Amp Demo Board |

Description

The TS1002 and the TS1004 demo boards provide two configurations for evaluating the TS1002 dual and the TS1004 quad operational amplifiers. A non-inverting gain of +2 configuration is located on the left-hand side of each board and an inverting gain of -1 configuration is located on the right-hand side of each board. In both cases, the input to each circuit is AC-coupled. The demo boards provide a re-biasing scheme at one-half the power supply or $V_{DD}/2$ for the inverting configuration and at $V_{DD}/4$ for the non-inverting configuration.

The TS1004 demo board provides resistor pads R3-R10 and Jumpers B and C in order to access op amps B and C. The default configuration for op amps B and C is a unity-gain. The non-inverting inputs are shorted to ground with 1Ω resistors on resistor pads R5 and R8 and the outputs are connected to the inverting inputs with 1Ω resistors on resistor pads R3 and R9.

In both the non-inverting and the inverting configuration, the AC-coupling capacitor creates a high pass filter. The resulting cut-off frequency, f_c , is given as:

$$f_c = \frac{1}{2\pi RC}$$

In the non-inverting circuit on the TS1002 demo board, $R=R4=1M\Omega$ and $C=C2=0.1\mu F$. In the inverting case, $R=R6=1M\Omega$ and $C=C3=0.1\mu F$. In the non-inverting circuit on the TS1004 demo board, $R=R17=1M\Omega$ and $C=C5=0.1\mu F$. In the inverting case, $R=R14=1M\Omega$ and $C=C4=0.1\mu F$. In both cases, these component values generate a high-pass cut-off frequency of 1.6Hz.

Default Configurations

Non-Inverting Configuration

In the non-inverting configuration, the circuit's transfer function is given by the following equation:

$$\frac{V_{OUT}}{V_{IN}} = 1 + \frac{RX}{RY}$$

With $R1=RX=2M\Omega$ and $R2=RY=2M\Omega$ on the TS1002 demo board and $R12=RX=2M\Omega$ and $R11=RY=2M\Omega$ on the TS1004 demo board, the circuit signal gain is +2 with a circuit bandwidth of 2kHz. This results in an overall circuit bandwidth range of 1.6Hz to 2kHz.

Inverting Configuration

In an inverting configuration, the circuit's transfer function is given by the following equation:

$$\frac{V_{OUT}}{V_{IN}} = -\frac{RX}{RY}$$

In this case, $R3=RX=1M\Omega$ and $R6=RY=1M\Omega$ on the TS1002 demo board and $R13=RX=1M\Omega$ and $R14=RY=1M\Omega$ on the TS1004 demo board. This results in a signal gain of -1 with a circuit bandwidth of 2kHz and an overall circuit bandwidth range of 1.6Hz to 2kHz.

Quick Start Procedures

Required Equipment

- TS1002 or TS1004 demo board
- DC Power Supply, Single or Dual Output
- Function Generator
- 4-channel Oscilloscope
- Two $1M\Omega$ oscilloscope probes

| Pin | Non-Inverting Circuit | Inverting Circuit |
|------------|-----------------------|-------------------|
| VDD | VDD | VDD |
| VSS | GND | GND |
| INA, INB | VIN | VIN-1 |
| OUTA, OUTB | VOUT | VOUT-1 |

Table 1. TS1002 Demo Board Test Points

| Pin | Non-Inverting Circuit | Inverting Circuit |
|------------|-----------------------|-------------------|
| VDD | VDD | VDD |
| VSS | GND | GND |
| INA, IND | VIN | VIN-1 |
| OUTD, OUTD | VOUT | VOUT-1 |

Table 2. TS1004 Demo Board Test Points

Non-Inverting Configuration

In order to evaluate the TS1002 dual or TS1004 quad operational amplifiers in the non-inverting configuration, the following steps are to be performed:

- 1) Before connecting the DC power supply to the demo board power test points, turn on the power supply and set the DC voltage to 2.5V and then turn it off.

- 2) Set the function generator frequency to 500Hz and output level with a $V_{OH} = 1.45V$ and a $V_{OL} = 1.05V$. This sets the input signal swing to $400mV_{PP}$, centered at 1.25V.
- 3) In order to monitor the input and output signal, select two channels on the oscilloscope and set the vertical voltage scale and the coupling setting on each channel to 200mV/DIV and AC, respectively. Set the input and output vertical position to +400mV and -200mV, respectively. Set the horizontal time scale to $500\mu s/DIV$.
- 4) Connect the positive terminal of the DC power supply to test point VDD and the negative terminal to test point GND on the TS1002 or TS1004 demo board. For all other connections, please refer to Table 1 and 2.
- 5) Connect the signal output of the function generator to test point VIN on the TS1002 or TS1004 demo board. Connect the ground terminal to test point GND.
- 6) To monitor the input, connect the signal terminal of one of the oscilloscope probes to test point VIN on the TS1002 or TS1004 demo board. Connect the ground terminal to test point GND. To monitor the output, use the second probe to connect the signal terminal to test point VOUT on the TS1002 or TS1004 demo board. Connect the ground terminal to test point GND.
- 7) Turn on the power supply and check that the power supply current is approximately $4.4\mu A$ for the TS1002 demo board and $5.5\mu A$ for the TS1004 demo board.
- 8) Turn on the function generator.
- 9) Observe the input and output signal. The output signal is an amplified version of the input signal with an output swing of approximately $800mV_{PP}$, corresponding to a signal gain of two. Figure 5 shows what the input and output signal should look like. The input signal is in yellow and the output signal is in green.

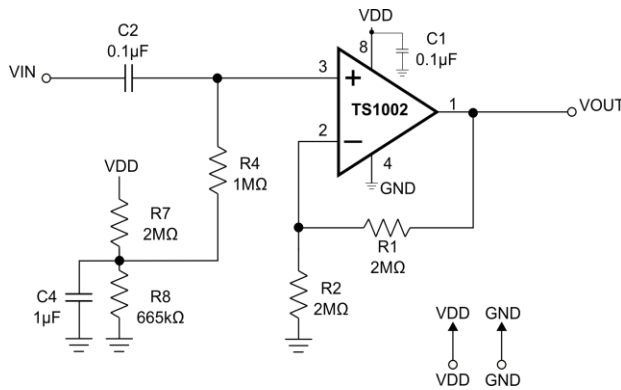

Figure 3. TS1002 Amp 'A' Non-Inverting Configuration

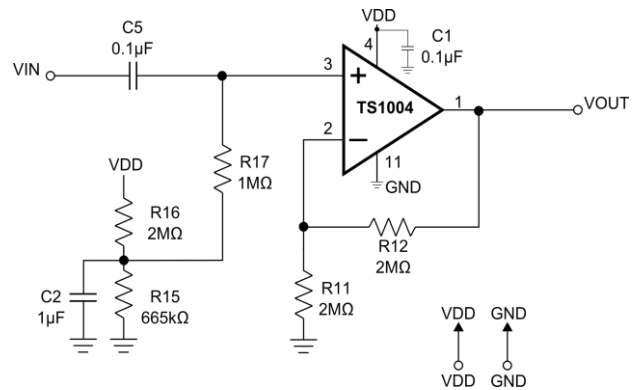

Figure 4. TS1004 Amp 'A' Non-Inverting Configuration

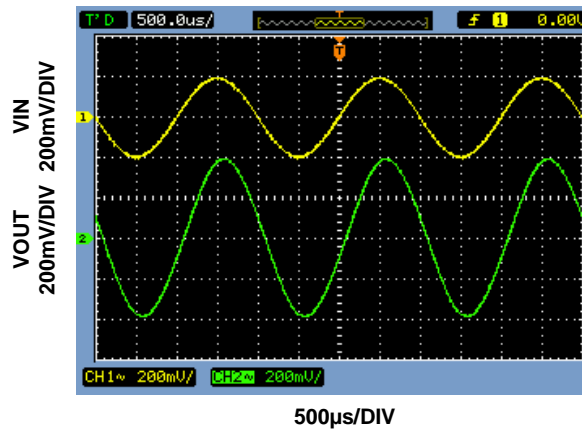

Figure 5. TS1002 and TS1004 Non-Inverting Configuration Input and Output signals

Inverting Configuration

In order to evaluate the TS1002 dual or TS1004 quad operational amplifiers in the inverting configuration, the following steps are to be performed:

- 1) Before connecting the DC power supply to the demo board, turn on the power supply and set the DC voltage to 2.5V and then turn it off.
- 2) Set the function generator output frequency to 500Hz and output level with a $V_{OH} = 1.45V$ and a $V_{OL} = 1.05V$. This sets the input swing to $400mV_{PP}$, centered at 1.25V.
- 3) In order to monitor the input and output signal, select two channels on the oscilloscope and set the vertical voltage scale and the coupling setting on each channel to 200mV/DIV and AC, respectively. Set the input and output vertical position to +400mV and -400mV, respectively. Set the horizontal time scale to 500 μ s/DIV.
- 4) Connect the positive terminal of the DC power supply to test point VDD and the negative terminal to test point GND on the TS1002 or TS1004 demo board. For all other connections, please refer to Table 1 and 2.
- 5) Connect the signal output of the function generator to test point VIN-1 on the TS1002 or TS1004 demo board. Connect the ground terminal to test point GND.
- 6) To monitor the input, connect the signal terminal of one of the oscilloscope probes to test point VIN-1 on the TS1002 or TS1004 demo board. Connect the ground terminal to test point GND. To monitor the output, use the second probe to connect the signal terminal to test point VOUT-1 on the TS1002 or TS1004 demo board. Connect the ground terminal to test point GND.
- 7) Turn on the power supply and check that the power supply current is approximately 4.4 μ A for the TS1002 demo board and 5.5 μ A for the TS1004 demo board.
- 8) Turn on the function generator.
- 9) Observe the input and output signal. The output signal is an inverted version of the input signal with an output swing of approximately $400mV_{PP}$, corresponding to a signal gain of negative one. Figure 8 shows what the input and output signal should look like. The input signal is in yellow and the output signal is in green.

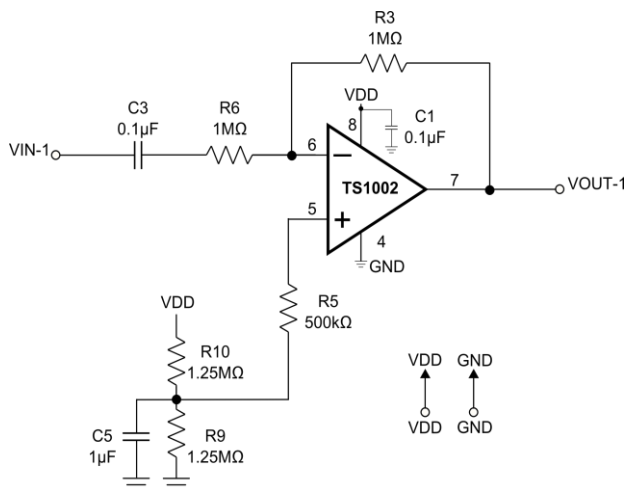

Figure 6. TS1002 Amp 'B' Inverting Configuration

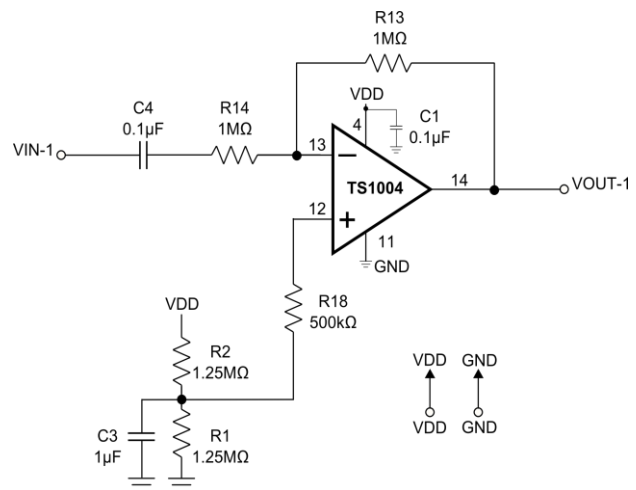

Figure 7. TS1004 Amp 'D' Inverting Configuration

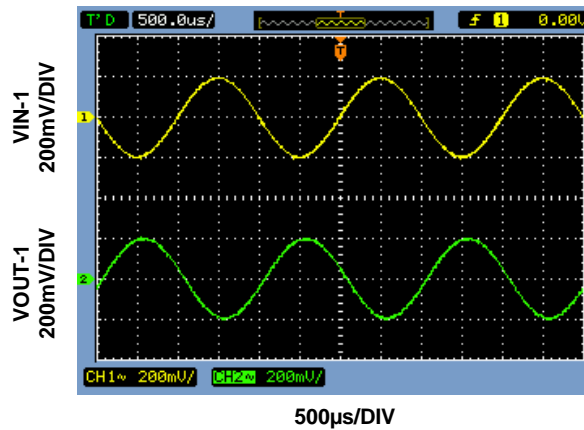

Figure 8. TS1002 and TS1004 Non-Inverting Configuration Input and Output signals

COMPONENT LIST

| DESIGNATION TS1002 | QTY | DESCRIPTION |
|-------------------------------|-----|-------------------------------|
| C1, C2, C3 | 3 | 0.1µF ± 10% capacitors (0805) |
| C4, C5 | 2 | 1µF ±10% capacitors (0805) |
| R8 | 1 | 665kΩ ± 1% resistor (0805) |
| R5 | 1 | 500kΩ ± 1% resistor (0805) |
| R3, R4, R6 | 3 | 1MΩ ± 1% resistors (0805) |
| R9, R10 | 2 | 1.25MΩ ± 1% resistors (0805) |
| R1, R2, R7 | 3 | 2MΩ ± 1% resistors (0805) |
| U1 | 1 | TS1002 Dual Op-Amps |
| VDD, VIN, VIN-1, VOUT, VOUT-1 | 5 | Test points |

| DESIGNATION TS1004 | QTY | DESCRIPTION |
|---|-----|-------------------------------|
| C1, C4, C5 | 3 | 0.1µF ± 10% capacitors (0805) |
| C2, C3 | 2 | 1µF ±10% capacitors (0805) |
| R15 | 1 | 665kΩ ± 1% resistor (0805) |
| R18 | 1 | 500kΩ ± 1% resistor (0805) |
| R13, R14, R17 | 3 | 1MΩ ± 1% resistors (0805) |
| R1, R2 | 2 | 1.25MΩ ± 1% resistors (0805) |
| R11, R12, R16 | 3 | 2MΩ ± 1% resistors (0805) |
| U1 | 2 | TS1004 Quad Op-Amps |
| VDD, VIN, VIN-1, VOUT, VOUT-1, Out_B, Out_C | 7 | Test points |

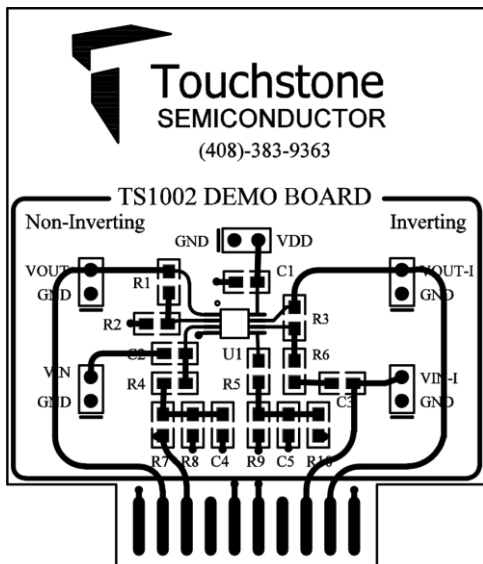

Figure 9. TS1002 Top Layer Component View

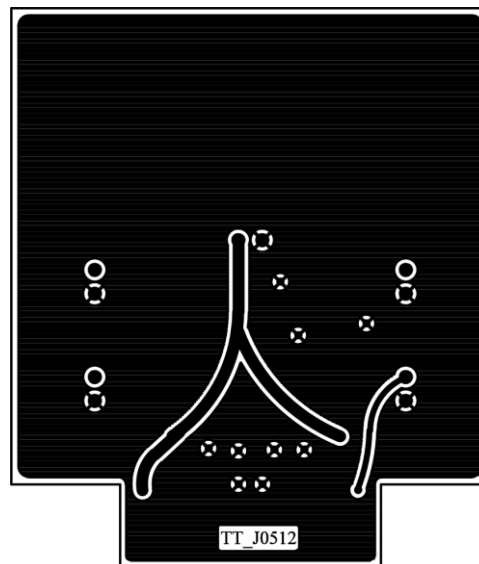

Figure 10. TS1002 Bottom Layer (GND) #1

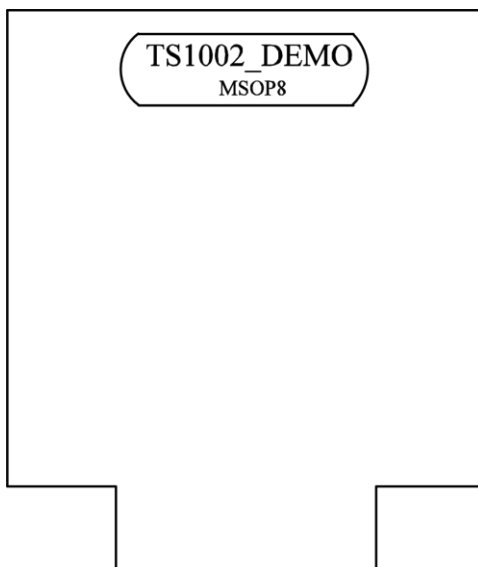

Figure 11. TS1002 Bottom Layer (GND) #2

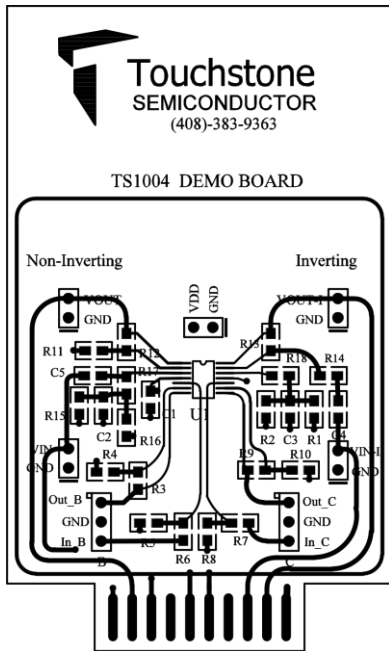

Figure 12. TS1004 Top Layer Component

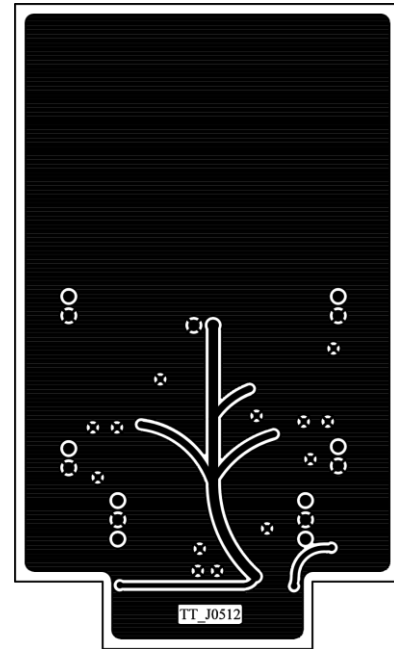

Figure 13. TS1004 Bottom Layer (GND) #1

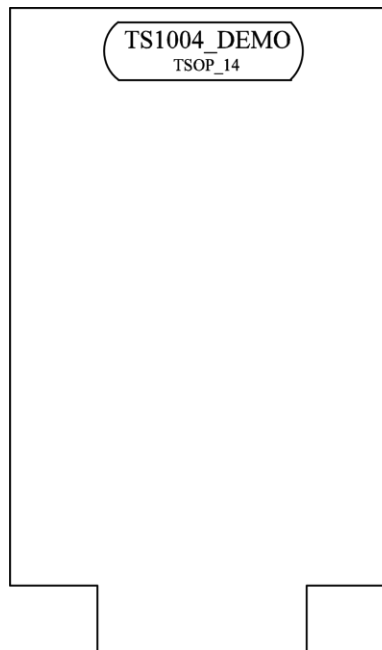

Figure 14. TS1004 Bottom Layer (GND) #2

Компания «Life Electronics» занимается поставками электронных компонентов импортного и отечественного производства от производителей и со складов крупных дистрибьюторов Европы, Америки и Азии.

С конца 2013 года компания активно расширяет линейку поставок компонентов по направлению коаксиальный кабель, кварцевые генераторы и конденсаторы (керамические, пленочные, электролитические), за счёт заключения дистрибьюторских договоров

Мы предлагаем:

- Конкурентоспособные цены и скидки постоянным клиентам.
- Специальные условия для постоянных клиентов.
- Подбор аналогов.
- Поставку компонентов в любых объемах, удовлетворяющих вашим потребностям.
- Приемлемые сроки поставки, возможна ускоренная поставка.
- Доставку товара в любую точку России и стран СНГ.
- Комплексную поставку.
- Работу по проектам и поставку образцов.
- Формирование склада под заказчика.
- Сертификаты соответствия на поставляемую продукцию (по желанию клиента).
- Тестирование поставляемой продукции.
- Поставку компонентов, требующих военную и космическую приемку.
- Входной контроль качества.
- Наличие сертификата ISO.

В составе нашей компании организован Конструкторский отдел, призванный помогать разработчикам, и инженерам.

Конструкторский отдел помогает осуществить:

- Регистрацию проекта у производителя компонентов.
- Техническую поддержку проекта.
- Защиту от снятия компонента с производства.
- Оценку стоимости проекта по компонентам.
- Изготовление тестовой платы монтаж и пусконаладочные работы.



Тел: +7 (812) 336 43 04 (многоканальный)

Email: org@lifeelectronics.ru