

**Boost chopper  
Trench + Field Stop IGBT®  
Power Module**

**$V_{CES} = 600V$   
 $I_C = 300A @ T_c = 80^\circ C$**

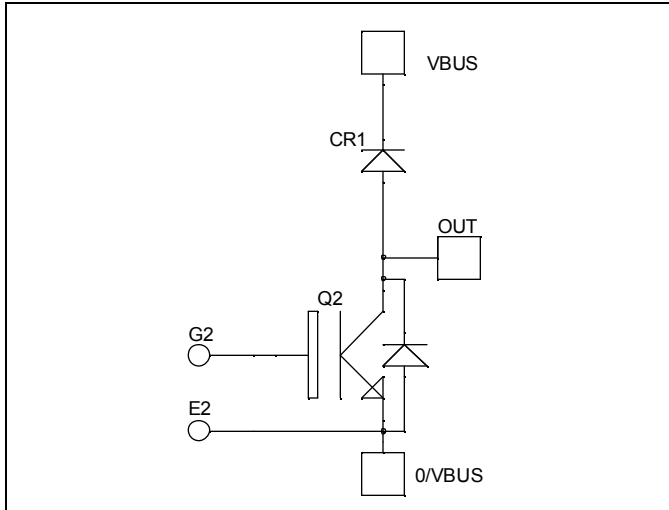

### Application

- AC and DC motor control
- Switched Mode Power Supplies
- Power Factor Correction

### Features

- Trench + Field Stop IGBT® Technology
  - Low voltage drop
  - Low tail current
  - Switching frequency up to 20 kHz
  - Soft recovery parallel diodes
  - Low diode VF
  - Low leakage current
  - Avalanche energy rated
  - RBSOA and SCSOA rated
- Kelvin emitter for easy drive
- Very low stray inductance
  - Symmetrical design
  - M5 power connectors
- High level of integration

### Benefits

- Stable temperature behavior
- Very rugged
- Direct mounting to heatsink (isolated package)
- Low junction to case thermal resistance
- Easy paralleling due to positive TC of VCEsat
- Low profile
- RoHS Compliant

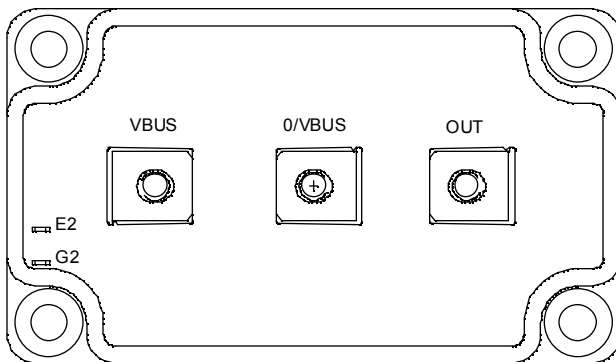

### Absolute maximum ratings

| Symbol    | Parameter                             | Max ratings         | Unit        |
|-----------|---------------------------------------|---------------------|-------------|
| $V_{CES}$ | Collector - Emitter Breakdown Voltage | 600                 | V           |
| $I_C$     | Continuous Collector Current          | $T_c = 25^\circ C$  | 430         |
|           |                                       | $T_c = 80^\circ C$  | 300         |
| $I_{CM}$  | Pulsed Collector Current              | $T_c = 25^\circ C$  | 500         |
| $V_{GE}$  | Gate - Emitter Voltage                | $\pm 20$            | V           |
| $P_D$     | Maximum Power Dissipation             | $T_c = 25^\circ C$  | 1150        |
| RBSOA     | Reverse Bias Safe Operating Area      | $T_j = 150^\circ C$ | 600A @ 550V |

**CAUTION:** These Devices are sensitive to Electrostatic Discharge. Proper Handling Procedures Should Be Followed. See application note APT0502 on [www.microsemi.com](http://www.microsemi.com)

All ratings @  $T_j = 25^\circ\text{C}$  unless otherwise specified

**Electrical Characteristics**

| Symbol        | Characteristic                       | Test Conditions                              | Min                       | Typ | Max | Unit          |
|---------------|--------------------------------------|--|---------------------------|-----|-----|---------------|
| $I_{CES}$     | Zero Gate Voltage Collector Current  | $V_{GE} = 0\text{V}, V_{CE} = 600\text{V}$   |                           |     | 350 | $\mu\text{A}$ |
| $V_{CE(sat)}$ | Collector Emitter Saturation Voltage | $V_{GE} = 15\text{V}$<br>$I_C = 300\text{A}$ | $T_j = 25^\circ\text{C}$  | 1.4 | 1.8 | V             |
|               |                                      |  | $T_j = 150^\circ\text{C}$ | 1.5 |     |               |
| $V_{GE(th)}$  | Gate Threshold Voltage               | $V_{GE} = V_{CE}, I_C = 1.5\text{ mA}$       | 5.0                       | 5.8 | 6.5 | V             |
| $I_{GES}$     | Gate – Emitter Leakage Current       | $V_{GE} = 20\text{V}, V_{CE} = 0\text{V}$    |                           |     | 500 | nA            |

**Dynamic Characteristics**

| Symbol       | Characteristic               | Test Conditions                                      | Min                       | Typ  | Max | Unit |
|--------------|------------------------------|--|---------------------------|------|-----|------|
| $C_{ies}$    | Input Capacitance            | $V_{GE} = 0\text{V}$                                 |                           | 24   |     | nF   |
| $C_{oes}$    | Output Capacitance           | $V_{CE} = 25\text{V}$                                |                           | 1.5  |     |      |
| $C_{res}$    | Reverse Transfer Capacitance | $f = 1\text{MHz}$                                    |                           | 0.75 |     |      |
| $T_{d(on)}$  | Turn-on Delay Time           | Inductive Switching ( $25^\circ\text{C}$ )           |                           | 115  |     | ns   |
| $T_r$        | Rise Time                    | $V_{GE} = \pm 15\text{V}$                            |                           | 45   |     |      |
| $T_{d(off)}$ | Turn-off Delay Time          | $V_{Bus} = 300\text{V}$                              |                           | 200  |     |      |
| $T_f$        | Fall Time                    | $I_C = 300\text{A}$<br>$R_G = 1.8\Omega$             |                           | 55   |     |      |
| $T_{d(on)}$  | Turn-on Delay Time           | Inductive Switching ( $150^\circ\text{C}$ )          |                           | 120  |     | ns   |
| $T_r$        | Rise Time                    | $V_{GE} = \pm 15\text{V}$                            |                           | 50   |     |      |
| $T_{d(off)}$ | Turn-off Delay Time          | $V_{Bus} = 300\text{V}$                              |                           | 250  |     |      |
| $T_f$        | Fall Time                    | $I_C = 300\text{A}$<br>$R_G = 1.8\Omega$             |                           | 70   |     |      |
| $E_{on}$     | Turn on Energy               | $V_{GE} = \pm 15\text{V}$<br>$V_{Bus} = 300\text{V}$ | $T_j = 25^\circ\text{C}$  | 1.5  |     | mJ   |
|              |                              |  | $T_j = 150^\circ\text{C}$ | 2.7  |     |      |
| $E_{off}$    | Turn off Energy              | $I_C = 300\text{A}$<br>$R_G = 1.8\Omega$             | $T_j = 25^\circ\text{C}$  | 8.55 |     | mJ   |
|              |                              |  | $T_j = 150^\circ\text{C}$ | 10.5 |     |      |

**Chopper diode ratings and characteristics**

| Symbol    | Characteristic                          | Test Conditions  | Min                       | Typ  | Max | Unit          |
|-----------|---|--|---------------------------|------|-----|---------------|
| $V_{RRM}$ | Maximum Peak Repetitive Reverse Voltage |  | 600                       |      |     | V             |
| $I_{RM}$  | Maximum Reverse Leakage Current         | $V_R = 600\text{V}$  | $T_j = 25^\circ\text{C}$  |      | 150 | $\mu\text{A}$ |
|           |   |  | $T_j = 150^\circ\text{C}$ |      | 400 |               |
| $I_F$     | DC Forward Current                      |  | $T_c = 80^\circ\text{C}$  | 300  |     | A             |
| $V_F$     | Diode Forward Voltage                   | $I_F = 300\text{A}$<br>$V_{GE} = 0\text{V}$                                      | $T_j = 25^\circ\text{C}$  | 1.5  | 1.9 | V             |
|           |   |  | $T_j = 150^\circ\text{C}$ | 1.4  |     |               |
| $t_{rr}$  | Reverse Recovery Time                   |  | $T_j = 25^\circ\text{C}$  | 130  |     | ns            |
|           |   |  | $T_j = 150^\circ\text{C}$ | 225  |     |               |
| $Q_{rr}$  | Reverse Recovery Charge                 | $I_F = 300\text{A}$<br>$V_R = 300\text{V}$<br>$di/dt = 3100\text{A}/\mu\text{s}$ | $T_j = 25^\circ\text{C}$  | 13.5 |     | $\mu\text{C}$ |
|           |   |  | $T_j = 150^\circ\text{C}$ | 28.5 |     |               |
| $E_r$     | Reverse Recovery Energy                 |  | $T_j = 25^\circ\text{C}$  | 3.5  |     | mJ            |
|           |   |  | $T_j = 150^\circ\text{C}$ | 7.1  |     |               |



## Typical Performance Curve

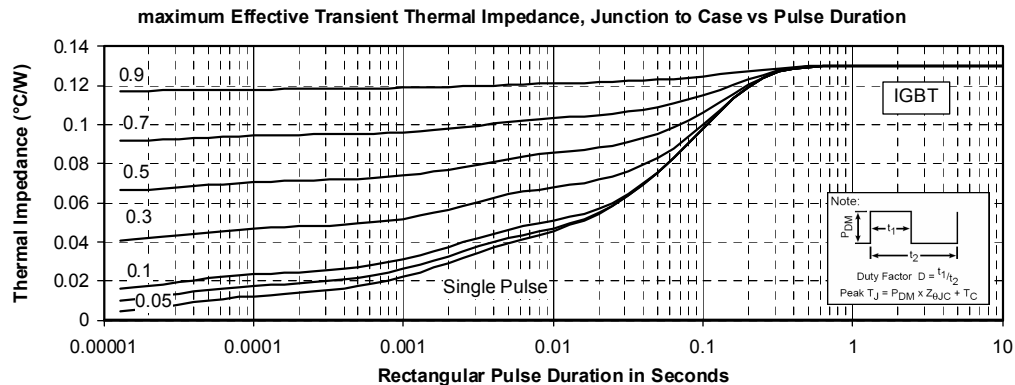
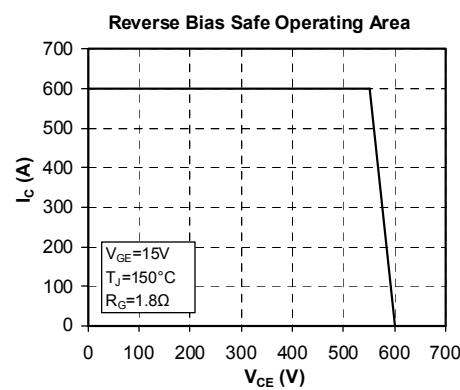
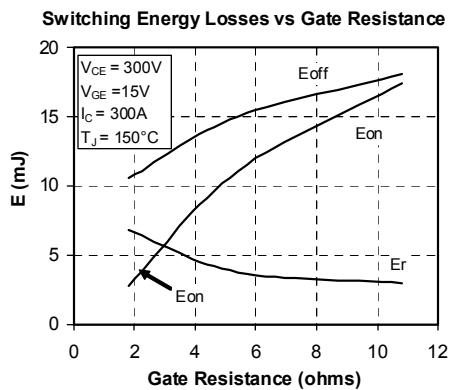
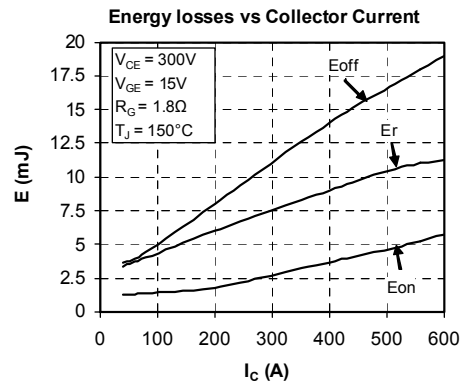
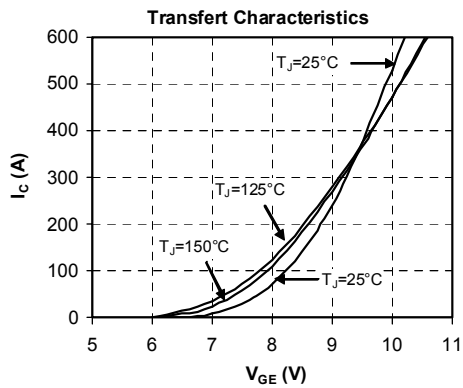
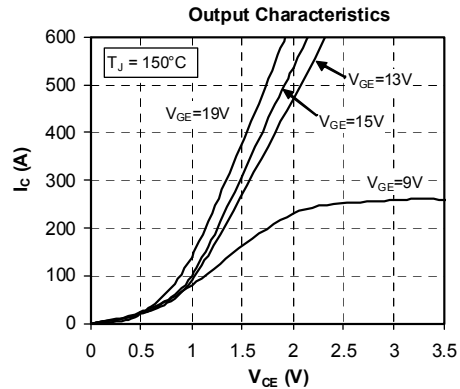
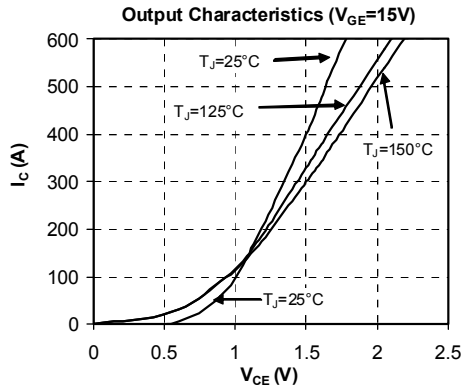

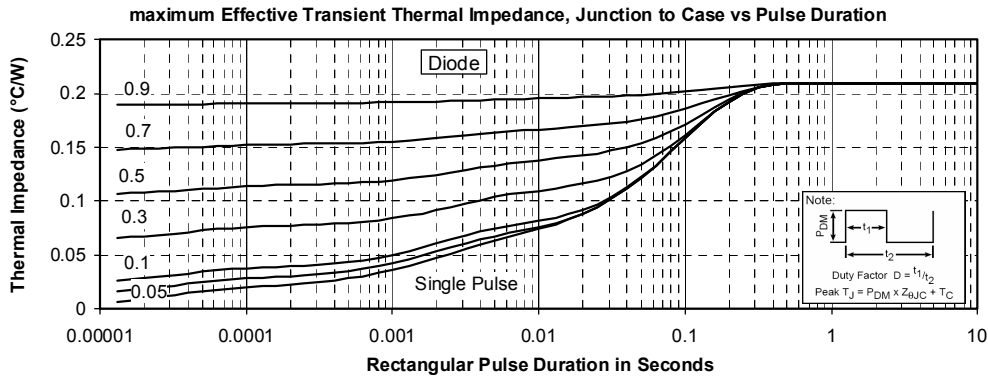
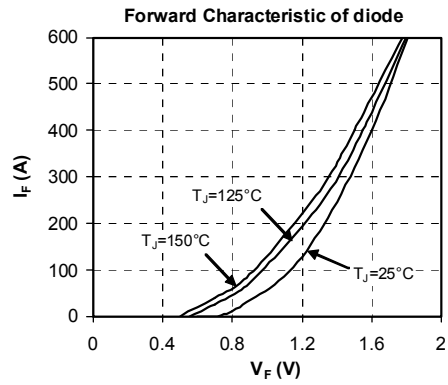
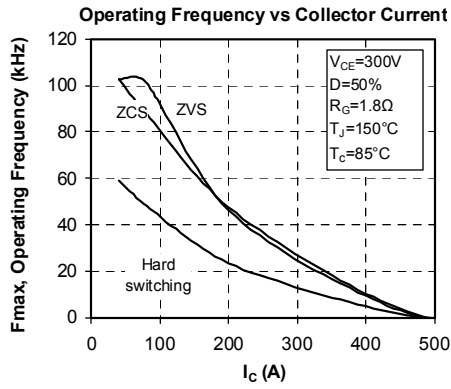

Microsemi reserves the right to change, without notice, the specifications and information contained herein

Microsemi's products are covered by one or more of U.S. patents 4,895,810 5,045,903 5,089,434 5,182,234 5,019,522 5,262,336 6,503,786 5,256,583 4,748,103 5,283,202 5,231,474 5,434,095 5,528,058 and foreign patents. U.S. and Foreign patents pending. All Rights Reserved.

Компания «Life Electronics» занимается поставками электронных компонентов импортного и отечественного производства от производителей и со складов крупных дистрибьюторов Европы, Америки и Азии.

С конца 2013 года компания активно расширяет линейку поставок компонентов по направлению коаксиальный кабель, кварцевые генераторы и конденсаторы (керамические, пленочные, электролитические), за счёт заключения дистрибьюторских договоров

Мы предлагаем:

- Конкурентоспособные цены и скидки постоянным клиентам.
- Специальные условия для постоянных клиентов.
- Подбор аналогов.
- Поставку компонентов в любых объемах, удовлетворяющих вашим потребностям.
- Приемлемые сроки поставки, возможна ускоренная поставка.
- Доставку товара в любую точку России и стран СНГ.
- Комплексную поставку.
- Работу по проектам и поставку образцов.
- Формирование склада под заказчика.
- Сертификаты соответствия на поставляемую продукцию (по желанию клиента).
- Тестирование поставляемой продукции.
- Поставку компонентов, требующих военную и космическую приемку.
- Входной контроль качества.
- Наличие сертификата ISO.

В составе нашей компании организован Конструкторский отдел, призванный помогать разработчикам, и инженерам.

Конструкторский отдел помогает осуществить:

- Регистрацию проекта у производителя компонентов.
- Техническую поддержку проекта.
- Защиту от снятия компонента с производства.
- Оценку стоимости проекта по компонентам.
- Изготовление тестовой платы монтаж и пусконаладочные работы.



Тел: +7 (812) 336 43 04 (многоканальный)

Email: [org@lifeelectronics.ru](mailto:org@lifeelectronics.ru)