



TO-251
(IPAK)



TO-252
(DPAK)



Pin Definition:

1. Gate
2. Drain
3. Source

PRODUCT SUMMARY

BV_{CEO}	400V
BV_{CBO}	700V
I_C	2A
$V_{CE(SAT)}$	1.1V @ $I_C / I_B = 1A / 0.25A$

Features

- Build-in Free-wheeling Diode Makes Efficient Anti-saturation Operation
- No Need to Interest an hfe Value Because of Low Variable Storage-time Spread Even Though Comer Spirit Product.
- Low Base Drive Requirement
- Suitable for Half Bridge Light Ballast Application

Structure

- Silicon Triple Diffused Type
- NPN Silicon Transistor with Diode

Ordering Information

Part No.	Package	Packing
TSC5302DCP RO	TO-252	2.5Kpcs / 13" Reel
TSC5302DCH C5	TO-251	70pcs / Tube

Block Diagram

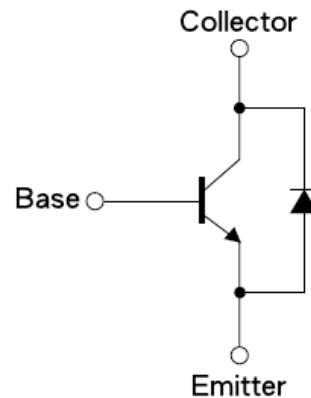

Absolute Maximum Rating (Ta = 25°C unless otherwise noted)

Parameter	Symbol	Limit	Unit
Collector-Base Voltage	V_{CBO}	700V	V
Collector-Emitter Voltage	V_{CEO}	400V	V
Emitter-Base Voltage	V_{EBO}	10	V
Collector Current	I_C	2	A
Collector Peak Current (tp < 5ms)	I_{CM}	4	A
Base Current	I_B	1	A
Base Peak Current (tp < 5ms)	I_{BM}	2	A
Total Dissipation @ Tc ≤ 25°C	TO-251	25	W
	TO-252	1.5	
Maximum Operating Junction Temperature	T_J	+150	°C
Storage Temperature Range	T_{STG}	-65 to +150	°C

Thermal Performance

Parameter	Symbol	Limit	Unit
Junction to Case Thermal Resistance	$R\theta_{JC}$	6.25	$^{\circ}\text{C/W}$
Junction to Ambient Thermal Resistance	$R\theta_{JA}$	100	$^{\circ}\text{C/W}$

Electrical Specifications (Ta = 25 $^{\circ}\text{C}$ unless otherwise noted)

Parameter	Conditions	Symbol	Min	Typ	Max	Unit
Static						
Collector-Base Voltage	$I_C = 1\text{mA}, I_E = 0$	BV_{CBO}	700	--	--	V
Collector-Emitter Breakdown Voltage ^a	$I_C = 10\text{mA}, I_E = 0$	BV_{CEO}	400	--	--	V
Emitter-Base Breakdown Voltage	$I_E = 1\text{mA}, I_C = 0$	BV_{EBO}	10	--	--	V
Collector Cutoff Current	$V_{CB} = 700\text{V}, I_E = 0$	I_{CBO}	--	--	1	μA
Emitter Cutoff Current	$V_{EB} = 9\text{V}, I_C = 0$	I_{EBO}	--	--	1	μA
Collector-Emitter Saturation Voltage ^a	$I_C = 0.5\text{A}, I_B = 0.1\text{A}$	$V_{CE(SAT)1}$	--	--	0.5	V
	$I_C = 1\text{A}, I_B = 0.25\text{A}$	$V_{CE(SAT)2}$	--	--	1.1	
Base-Emitter Saturation Voltage ^a	$I_C = 0.5\text{A}, I_B = 0.1\text{A}$	$V_{BE(SAT)1}$	--	--	1.1	V
	$I_C = 1\text{A}, I_B = 0.25\text{A}$	$V_{BE(SAT)2}$	--	--	1.2	
DC Current Gain	$V_{CE} = 5\text{V}, I_C = 10\text{mA}$	$h_{FE} 1$	10	--	--	
	$V_{CE} = 5\text{V}, I_C = 400\text{mA}$	$h_{FE} 2$	10	--	30	
	$V_{CE} = 5\text{V}, I_C = 1\text{A}$	$h_{FE} 3$	5	--	--	
Turn On Time	$V_{CC} = 250\text{V}, I_C = 1\text{A}$,	t_{ON}	--	0.15	0.3	μS
Storage Time	$I_{B1} = I_{B2} = 0.2\text{A}, t_p = 25\mu\text{S}$	t_{STG}	--	0.5	0.9	μS
Fall Time	Duty Cycle < 1%	t_f	--	0.2	0.4	μS
Diode						
Fall Time	$I_C = 1\text{A}$	t_f	--	--	800	μS
Forward Voltage Drop	$I_C = 1\text{A}$	V_f	--	--	1.4	V

Notes:

a. Pulsed duration = 300 μS , duty cycle $\leq 2\%$

Electrical Characteristics Curve ($T_a = 25^\circ\text{C}$, unless otherwise noted)

Figure 1. Static Characteristics

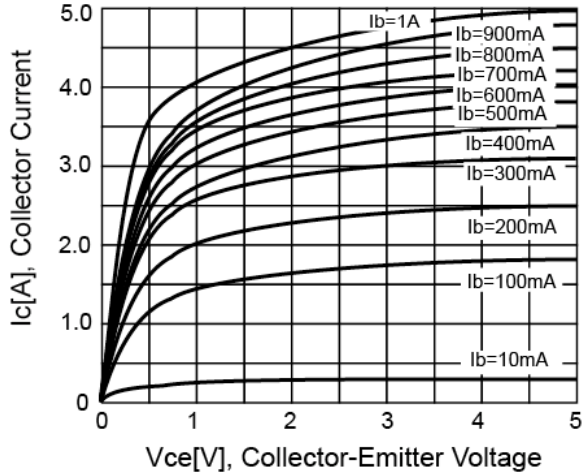

Figure 2. DC Current Gain

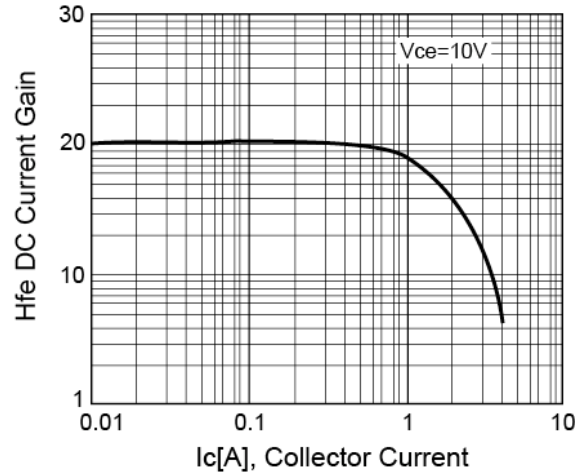

Figure 3. Vce(sat) v.s. Vbe(sat)

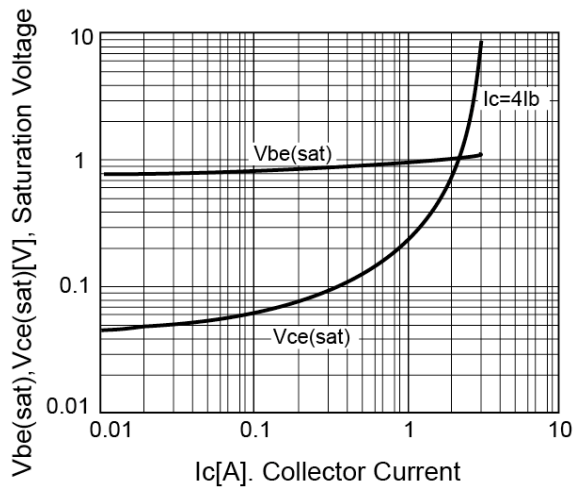
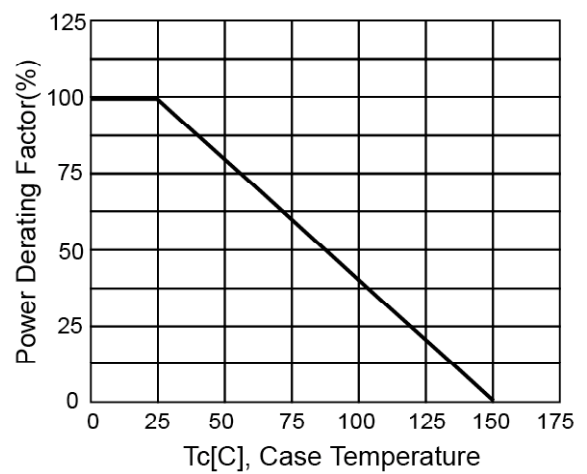
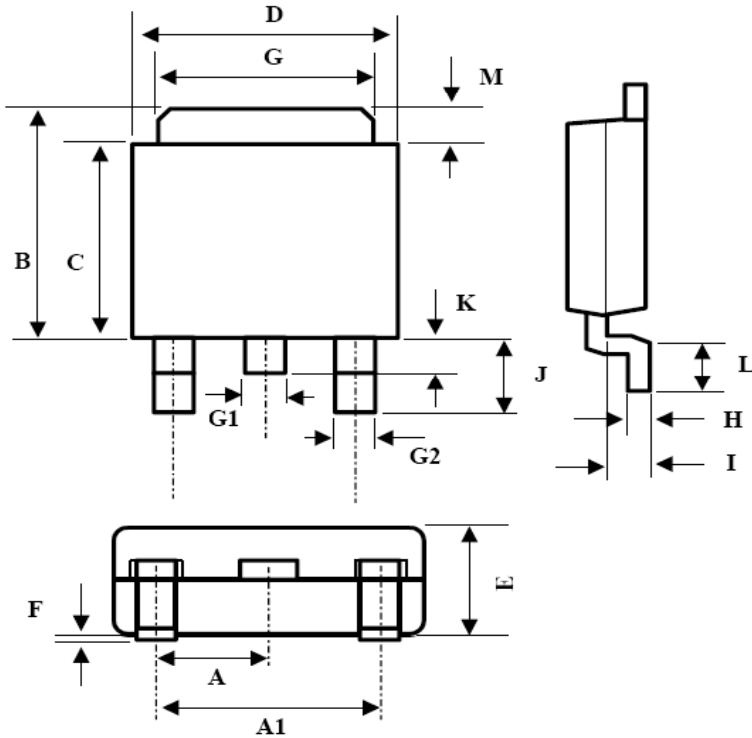

Figure 4. Power Derating



SOT-252 Mechanical Drawing



TO-252 DIMENSION				
DIM	MILLIMETERS		INCHES	
	MIN	MAX	MIN	MAX
A	2.3BSC		0.09BSC	
A1	4.6BSC		0.18BSC	
B	6.80	7.20	0.268	0.283
C	5.40	5.60	0.213	0.220
D	6.40	6.65	0.252	0.262
E	2.20	2.40	0.087	0.094
F	0.00	0.20	0.000	0.008
G	5.20	5.40	0.205	0.213
G1	0.75	0.85	0.030	0.033
G2	0.55	0.65	0.022	0.026
H	0.35	0.65	0.014	0.026
I	0.90	1.50	0.035	0.059
J	2.20	2.80	0.087	0.110
K	0.50	1.10	0.020	0.043
L	0.90	1.50	0.035	0.059
M	1.30	1.70	0.051	0.67

Marking Diagram

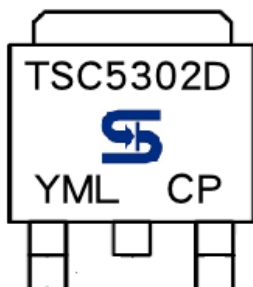

- Y = Year Code
- M = Month Code
(A=Jan, B=Feb, C=Mar, D=Apl, E=May, F=Jun, G=Jul, H=Aug, I=Sep, J=Oct, K=Nov, L=Dec)
- L = Lot Code

SOT-251 Mechanical Drawing

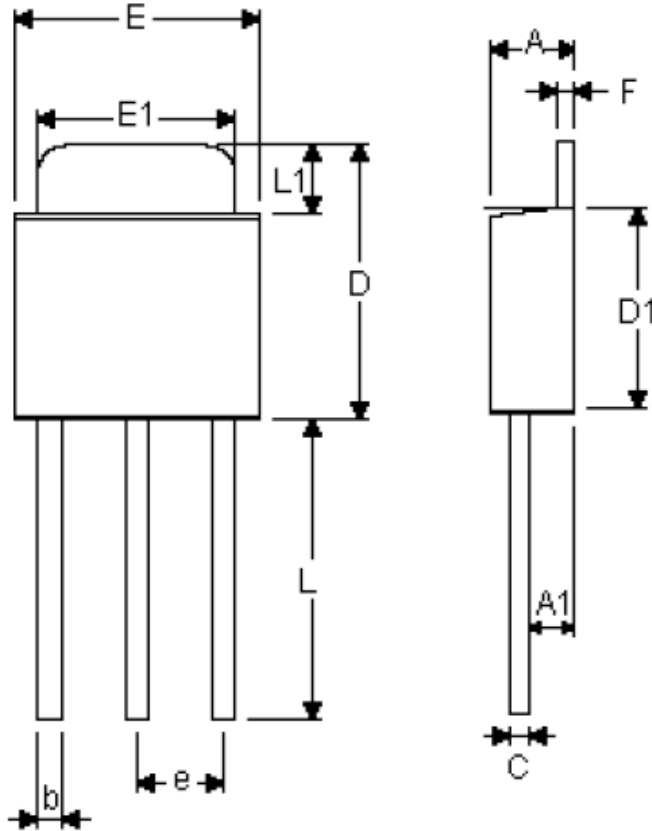

DIM	MILLIMETERS		INCHES	
	MIN	MAX	MIN	MAX
A	2.20	2.40	0.087	0.094
A1	1.10	1.30	0.043	0.051
b	0.55	0.75	0.022	0.030
C	0.48	0.58	0.019	0.023
D	6.50	7.00	0.256	0.276
D1	5.50	5.70	0.217	0.224
E	6.40	6.60	0.252	0.260
E1	5.20	5.40	0.205	0.213
e	2.25	2.35	0.089	0.093
F	0.48	0.58	0.019	0.023
L	7.80	8.20	0.307	0.323
L1	1.00	1.30	0.039	0.051

Marking Diagram

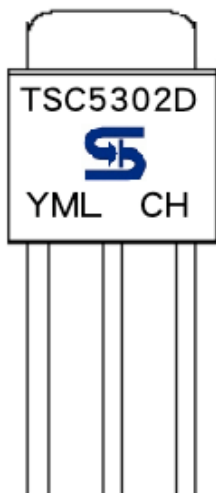

- Y = Year Code
- M = Month Code
(A=Jan, B=Feb, C=Mar, D=Apr, E=May, F=Jun, G=Jul, H=Aug, I=Sep, J=Oct, K=Nov, L=Dec)
- L = Lot Code

Notice

Specifications of the products displayed herein are subject to change without notice. TSC or anyone on its behalf, assumes no responsibility or liability for any errors or inaccuracies.

Information contained herein is intended to provide a product description only. No license, express or implied, to any intellectual property rights is granted by this document. Except as provided in TSC's terms and conditions of sale for such products, TSC assumes no liability whatsoever, and disclaims any express or implied warranty, relating to sale and/or use of TSC products including liability or warranties relating to fitness for a particular purpose, merchantability, or infringement of any patent, copyright, or other intellectual property right.

The products shown herein are not designed for use in medical, life-saving, or life-sustaining applications. Customers using or selling these products for use in such applications do so at their own risk and agree to fully indemnify TSC for any damages resulting from such improper use or sale.

Компания «Life Electronics» занимается поставками электронных компонентов импортного и отечественного производства от производителей и со складов крупных дистрибьюторов Европы, Америки и Азии.

С конца 2013 года компания активно расширяет линейку поставок компонентов по направлению коаксиальный кабель, кварцевые генераторы и конденсаторы (керамические, пленочные, электролитические), за счёт заключения дистрибьюторских договоров

Мы предлагаем:

- Конкурентоспособные цены и скидки постоянным клиентам.
- Специальные условия для постоянных клиентов.
- Подбор аналогов.
- Поставку компонентов в любых объемах, удовлетворяющих вашим потребностям.
- Приемлемые сроки поставки, возможна ускоренная поставка.
- Доставку товара в любую точку России и стран СНГ.
- Комплексную поставку.
- Работу по проектам и поставку образцов.
- Формирование склада под заказчика.
- Сертификаты соответствия на поставляемую продукцию (по желанию клиента).
- Тестирование поставляемой продукции.
- Поставку компонентов, требующих военную и космическую приемку.
- Входной контроль качества.
- Наличие сертификата ISO.

В составе нашей компании организован Конструкторский отдел, призванный помогать разработчикам, и инженерам.

Конструкторский отдел помогает осуществить:

- Регистрацию проекта у производителя компонентов.
- Техническую поддержку проекта.
- Защиту от снятия компонента с производства.
- Оценку стоимости проекта по компонентам.
- Изготовление тестовой платы монтаж и пусконаладочные работы.



Тел: +7 (812) 336 43 04 (многоканальный)
Email: org@lifeelectronics.ru